

作成承認印

配布許可印



AF-S VR Micro Nikkor 105mm / f2.8G

JAA63051 (MADE IN JAPAN)

REPAIR MANUAL

Nikon | NIKON CORPORATION
Tokyo, Japan

Copyright © 2006 by Nikon Corporation.
All Rights Reserved.
無断転載を禁ず !!

Specifications

Type of lens:	G-type AF-S Micro-Nikkor lens with built-in CPU and Nikon bayonet mount
Focal length:	105mm
Maximum aperture:	f/2.8
Lens construction:	14 elements in 12 groups (1 ED glass and 1 Nano Crystal Coat-deposited lens elements)
Picture angle:	23°20' [15°20' with Nikon digital cameras (Nikon DX format); 18°40' with IX240 system cameras]
Reproduction ratio:	1:10 to 1:1 (life-size)
Distance information:	Output to camera body
Focusing:	Nikon Internal Focusing (IF) system (utilizing an internal Silent Wave Motor); manually via separate focus ring
Focusing limit switch:	Provided; two ranges available: Full (∞-0.314m) or ∞-0.5m
Vibration reduction:	Lens-shift method using voice coil motors (VCMs)
Shooting distance scale:	Graduated in meters and feet from 0.314m (1 ft.) to infinity (∞)
Closest focus distance:	0.314m (1 ft.) (life-size)
No. of diaphragm blades:	9 pcs. (rounded)
Diaphragm:	Fully automatic
Aperture range:	f/2.8 to f/32
Exposure measurement:	Via full-aperture method
Attachment size:	62mm (P = 0.75mm)
Dimensions:	Approx. 83mm dia. x 116mm extension from the camera's lens mount flange
Weight:	Approx. 790g (27.9 oz)

Specifications and designs are subject to change without any notice or obligation on the part of the manufacturer.

※ Before Disassembly / (Re)assembly / Adjustment

On this lens, the VR (vibration-reduction) unit is mounted to correct the picture blur.

In order to maintain the functional accuracy of the picture blur correction, if detaching the VR (vibration-reduction) unit and gyro base plate or if removing the main PCB unit, be sure to adjust the VR by using the VR lens adjustment equipment (J15380) .

However, if disassembling the parts except the above, the VR adjustment is NOT necessary.

At service agencies where the "VR lens adjustment equipment" is not prepared, do NEITHER disassemble NOR repair the products of the above case.

Removing the 1-1st lens group or 5th lens group of this lens needs the lens alignment work after the assembly. Therefore, at service facilities where the lens alignment cannot be performed, do NOT remove the 1-1st lens group nor 5th lens group.

Caution:

- ① When disassembling, make sure to memorize the processing state of wires, screws to be fixed and their types, etc.
- ② Because prototypes are used for "Disassembly/(Re)assembly/Adjustment", they may differ from the actual products in forms, etc.
- ③ Because pictures are processed by a special method, they may differ from the actual ones in texture.

Points to notice for Lead-free solder products
<ul style="list-style-type: none"> ▪ Lead-free solder is used for this product. ▪ For soldering work, the special solder and soldering iron are required. ▪ Do NOT mix up lead-free solder with traditional solder. ▪ Use the special soldering iron respectively for lead-free solder and lead solder. They cannot be used in common.

1. DISASSEMBLY

VR name plate

- Remove the VR name plate (which is attached with the adhesive double-coated tape).



Front cover sheet

- Remove the front cover sheet (which is attached with the adhesive double-coated tape).



Rear cover ring

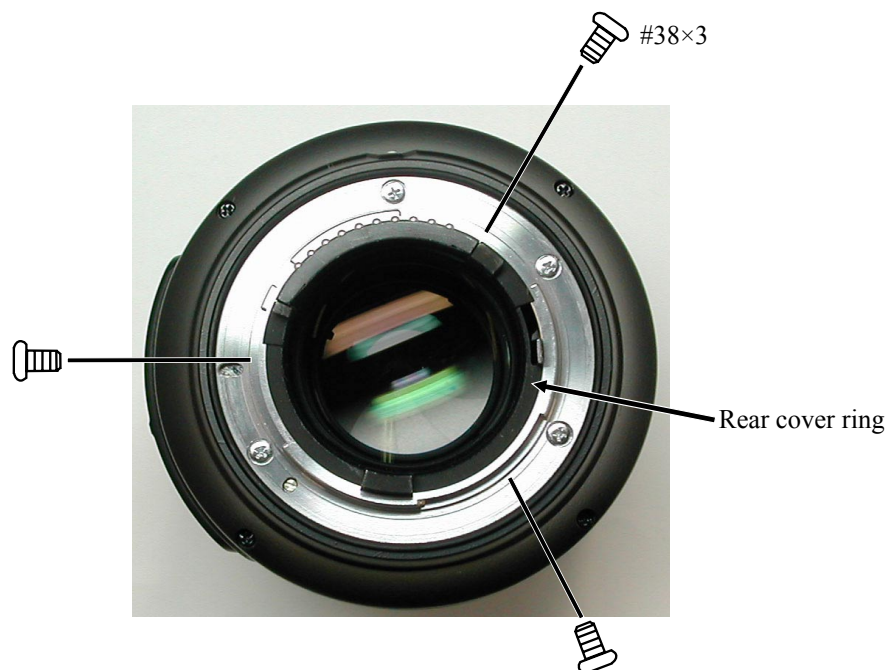

Bayonet mount

- ① Take out the two screws (#66) to remove the contact unit.
- ② Take out the four screws (#136) to remove the bayonet mount.
- ③ Take out the washer (#176).

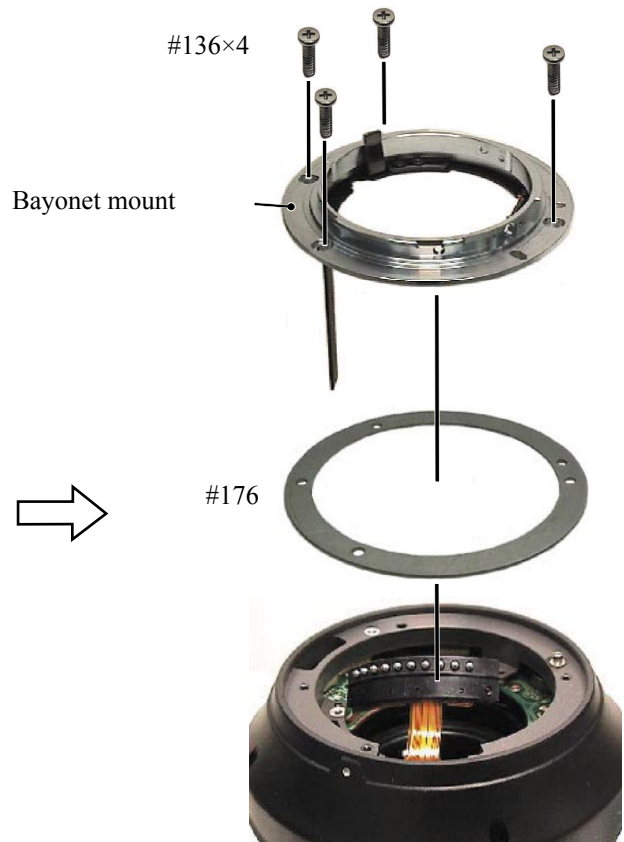
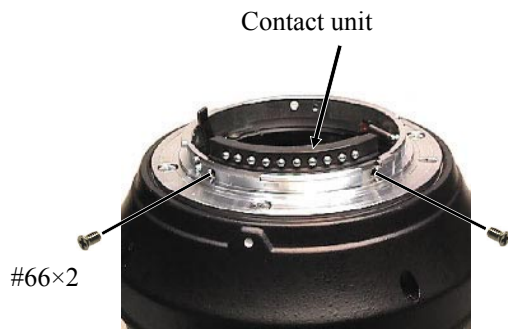

5th lens group

Caution:

Removing the 5th lens group needs the lens alignment work after the assembly.

Therefore, at service facilities where the lens alignment cannot be performed, do NOT remove the 5th lens group.

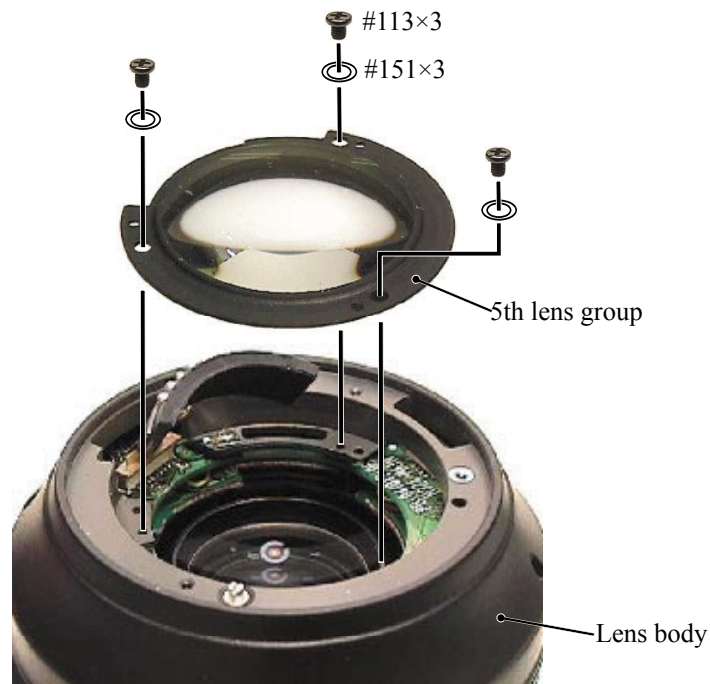

VR lens group unit

- ① Turn the VR SW to OFF.
- ② Align the concave portion of the VR-fixing tool (★ J11321) and the FPC of the contact unit, and fit the two pins of the tool into the two holes of the lens. Then assemble the VR-fixing tool into the lens.

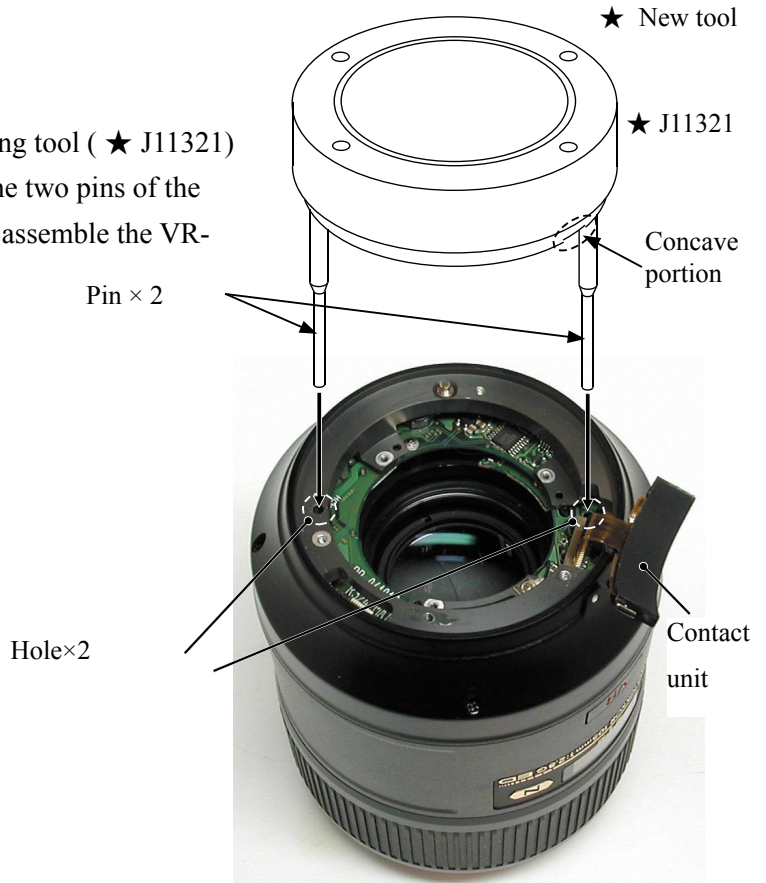

- ③ Remove the VR lens group and washer(s) (#138 selected from A ~ J) with the VR lens-assembling tool (★ J11324).
- ④ Remove the VR-fixing tool (★ J11321) from the lens.

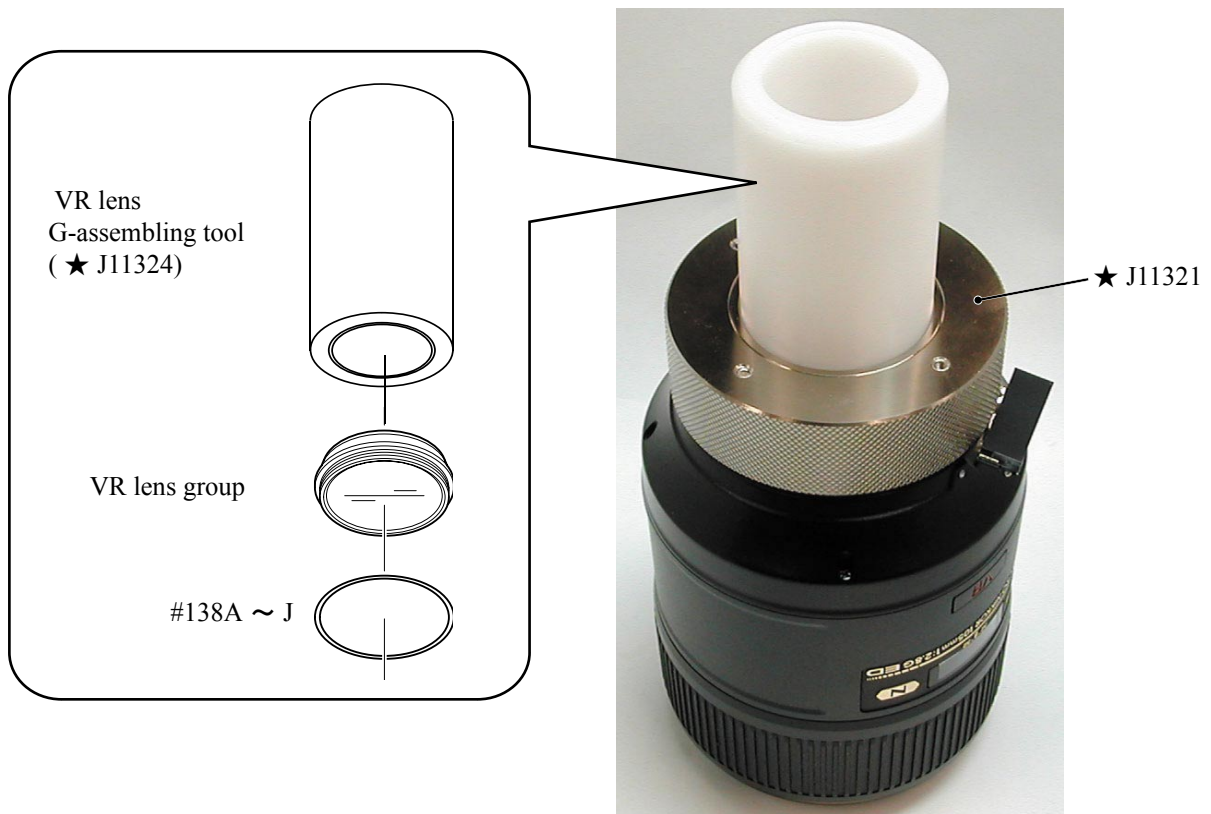

3rd lens group



3rd lens group

3rd lens-G
assembling tool
(★ J11323)

2nd lens group, 1-2nd lens group, 1-1st lens group

Removing the 1-1st lens group needs the lens alignment work after the assembly. Therefore, at service facilities where the lens alignment cannot be performed, do NOT remove the 1-1st lens group.

- ① Take out the four screws (#142) and the four washers (#151). Then remove the 1-1st lens group and the washer(s) (#152 selected from A-J).
- ② Remove the 1-2nd lens group and the washer(s) (#137 selected from A-J) with the 1-2nd lens-G assembling tool (★ J11320).
- ③ Remove the 2nd lens group.

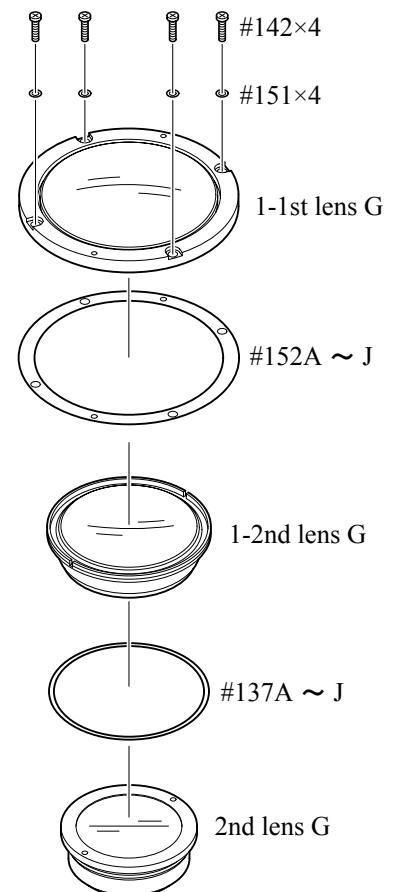

Rubber ring



Filter ring unit

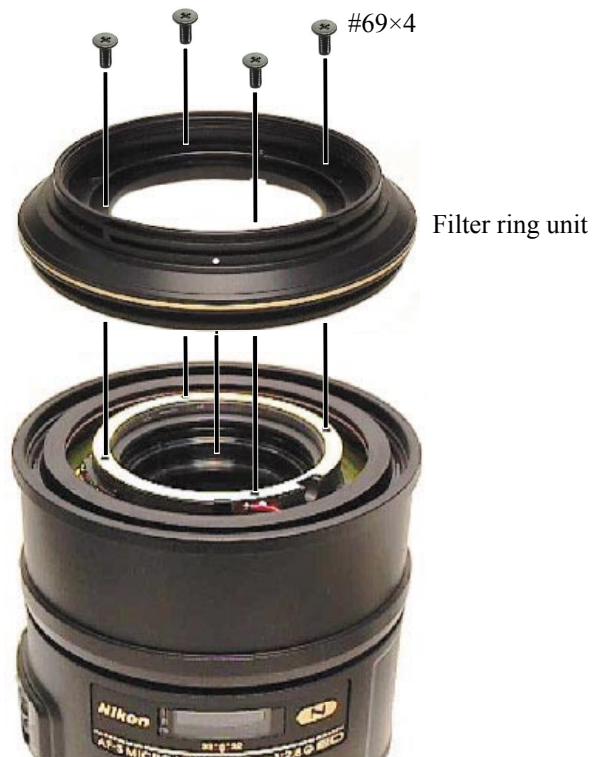

Focus ring (2) unit



Focus ring (2) unit



Focus ring (1) unit

Focus ring (1) unit



#139×2

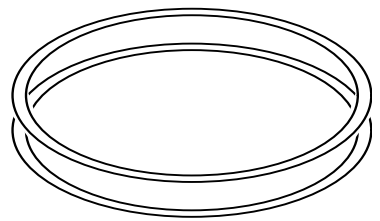

#27

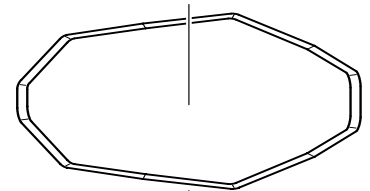

#139×2

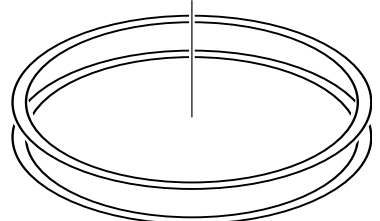

MF brush unit

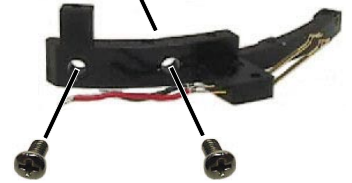
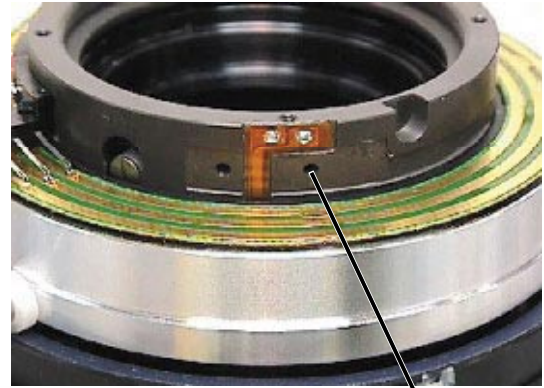
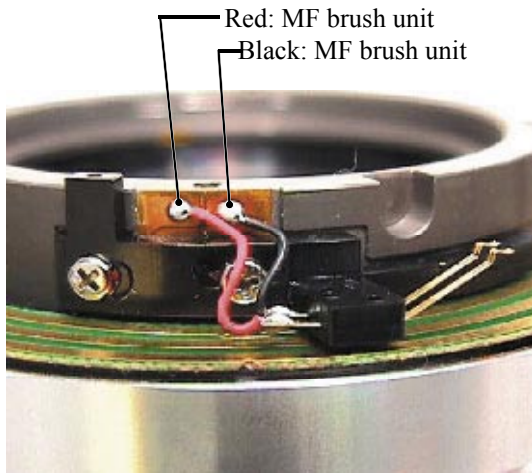

Power source brush unit

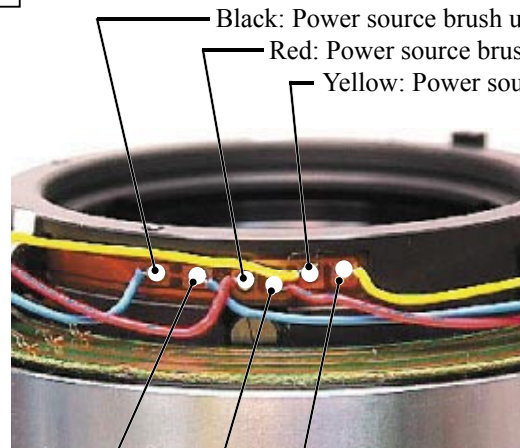

Yellow: Power source brush unit 2
Red: Power source brush unit 2
Black: Power source brush unit 2

Caution: After removing the wires, suck the solder off completely. Otherwise, the SWM unit cannot be removed.

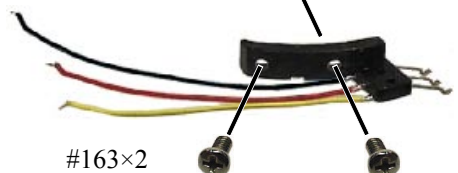

SWM unit



Caution:
When disassembling, Do NOT touch the upper surface of the pattern.



Change SW unit

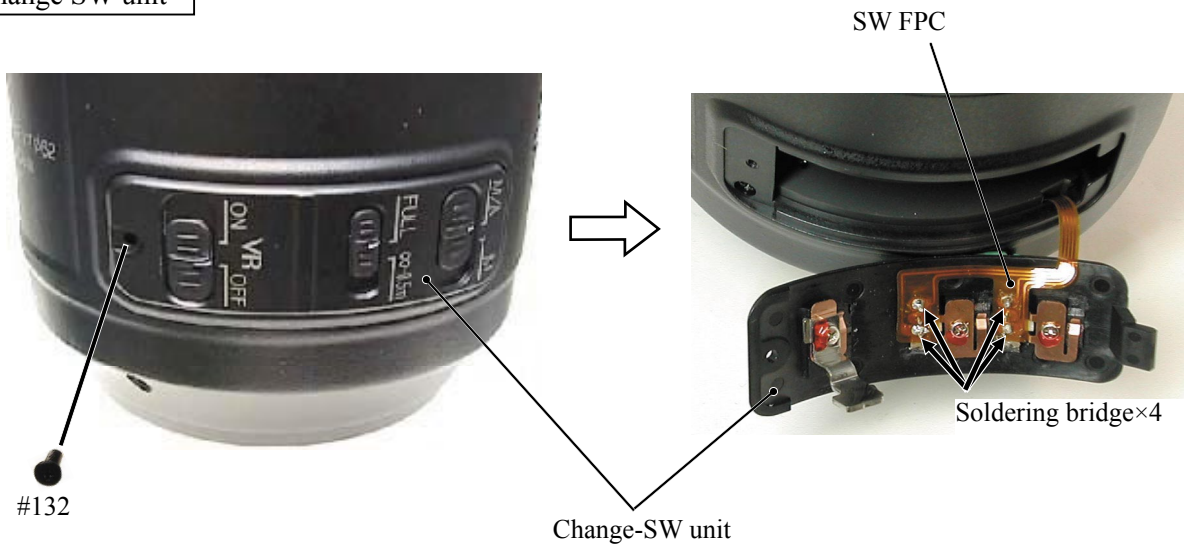

Name plate

window △ (Misdescription)

Caution: The name plate and focus ring do not have to be removed except the case when parts are replaced.

- ① Remove the name plate (#95) (which is attached with the adhesive double-coated tape).
- ② Remove the focus window (#94) (which is attached with the adhesive double-coated tape).



External tube unit

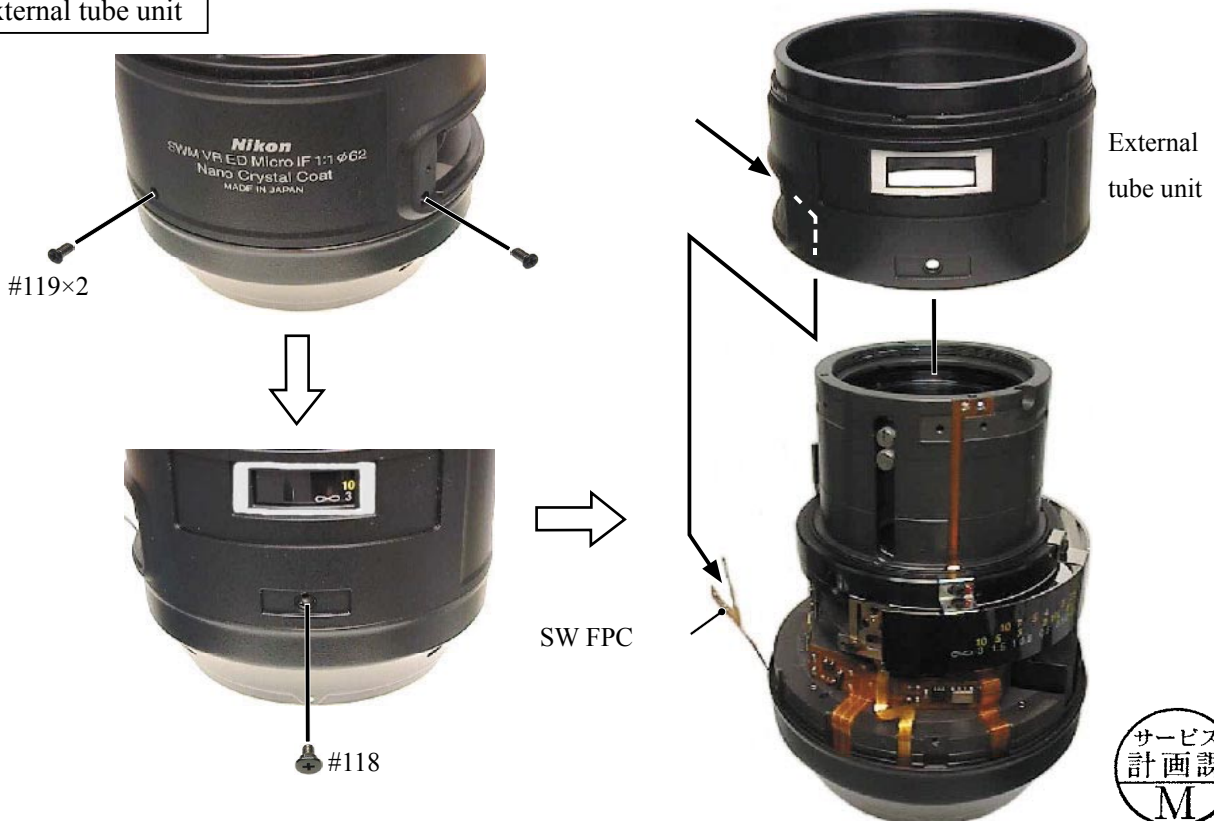

Focus index unit

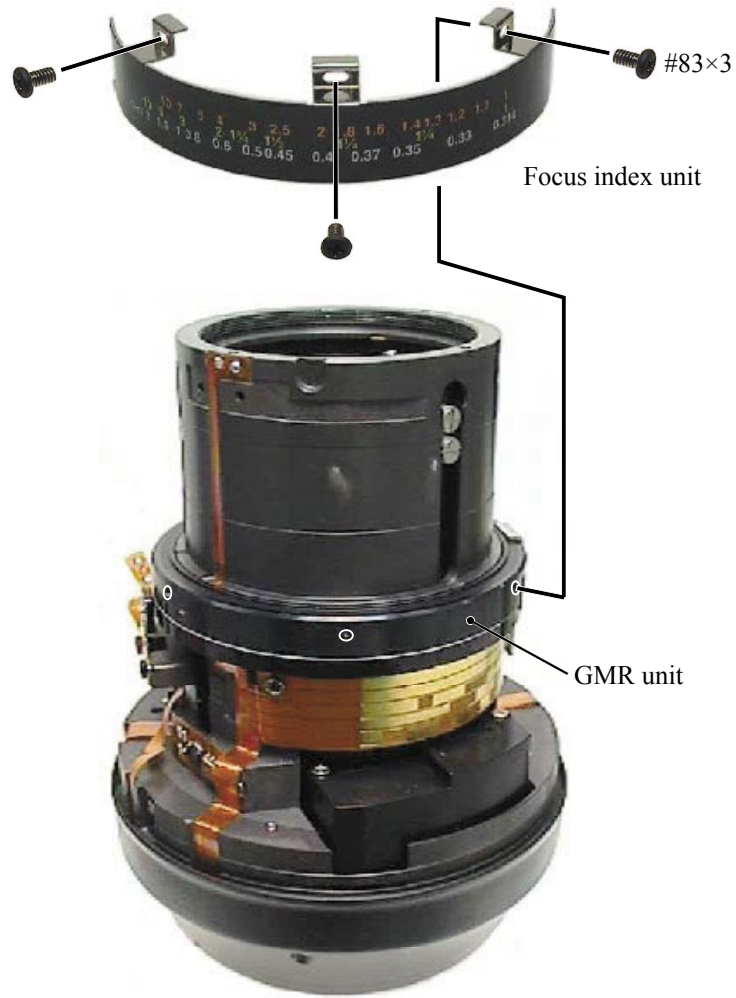

Rear outer tube unit

① Take out the screw (#144), and remove the lug plate.
(ref. Fig. 1)

② Take out the four screw (#154), and remove the rear outer tube unit.
Rear outer tube unit

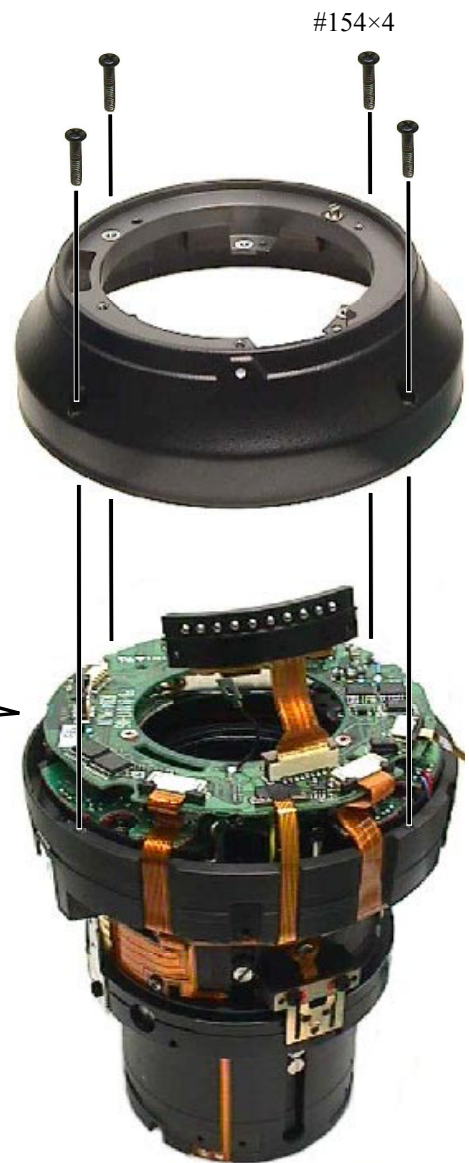
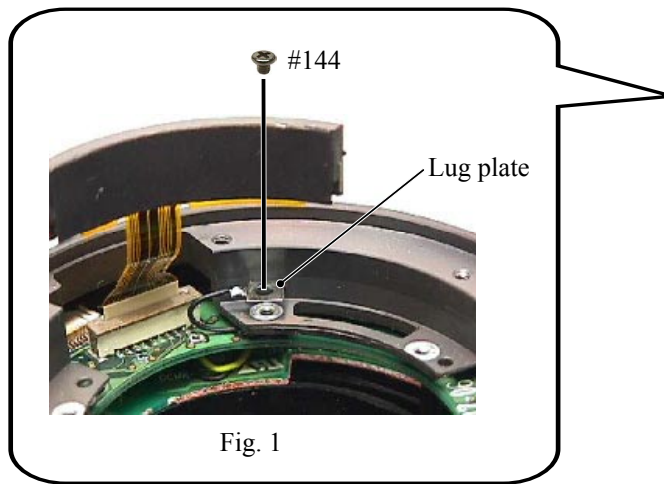

③ Remove the positioning pin (#97).

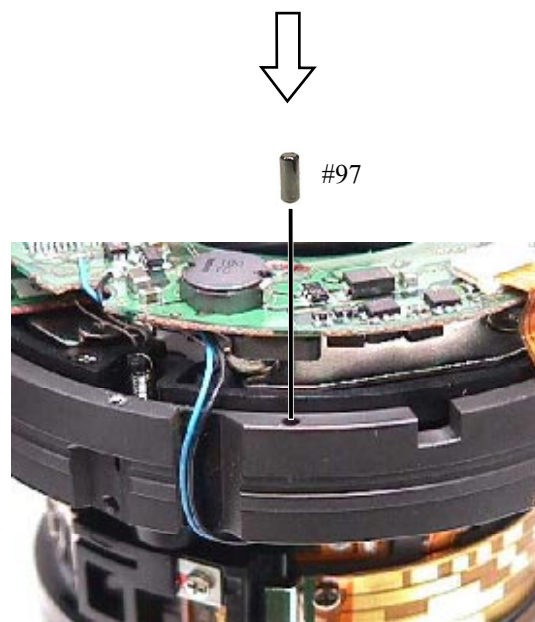

Mechanical-coupled block

- ① Take out the screw (#113).



- ② Take out the two screws (#113), and remove the block-retaining plate (#184).

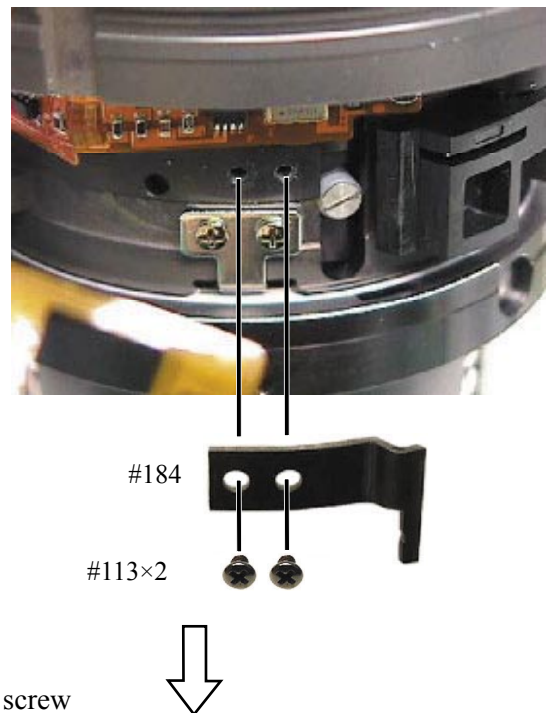

- ③ Remove the mechanical-coupled block. Then attach the screw (#113) temporarily that was taken out in ①.

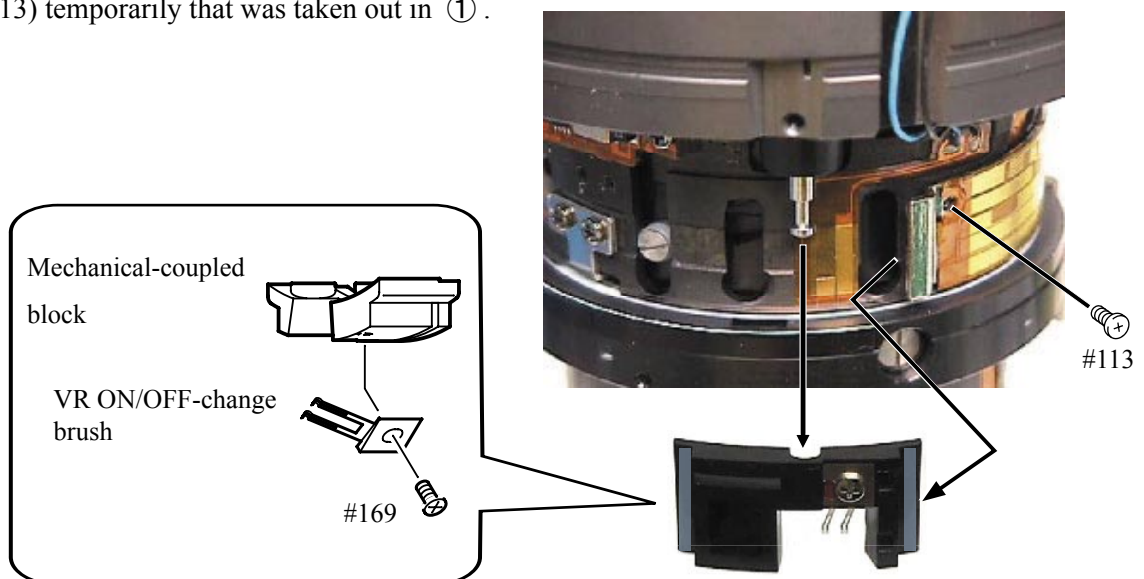

Main PCB unit

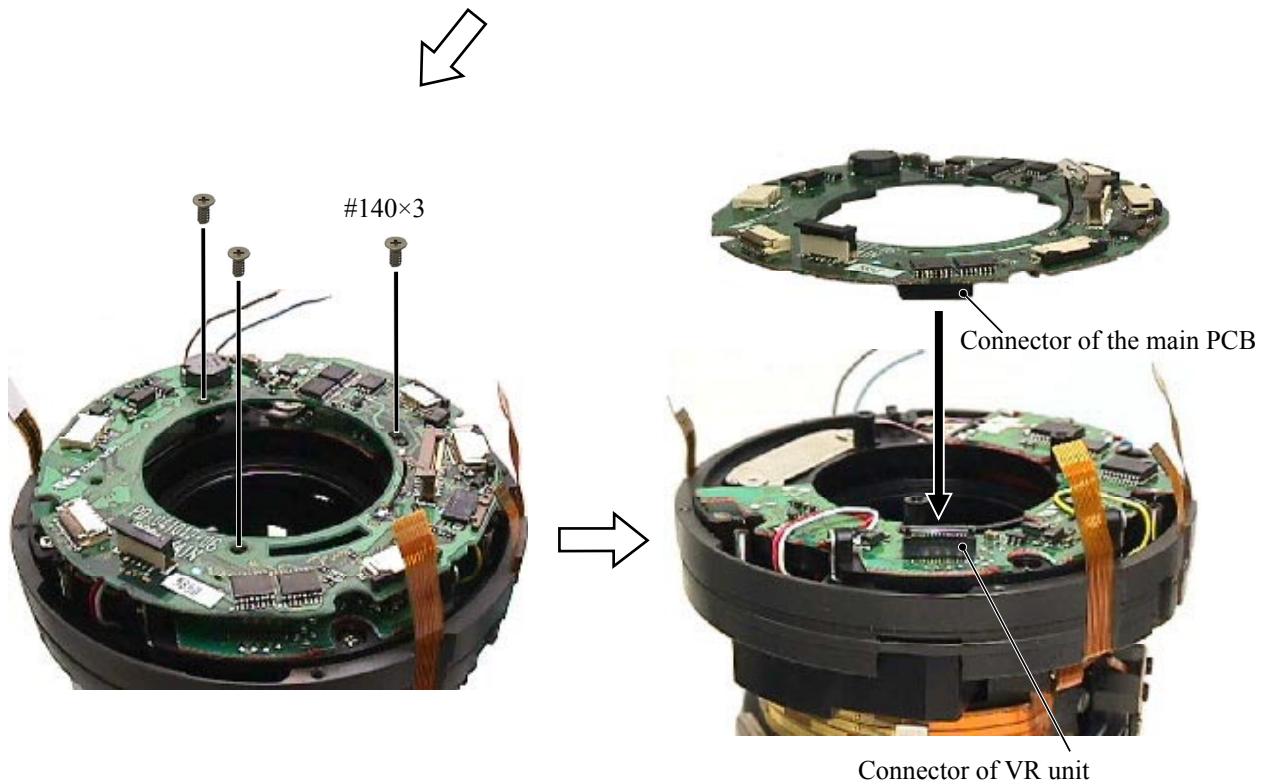
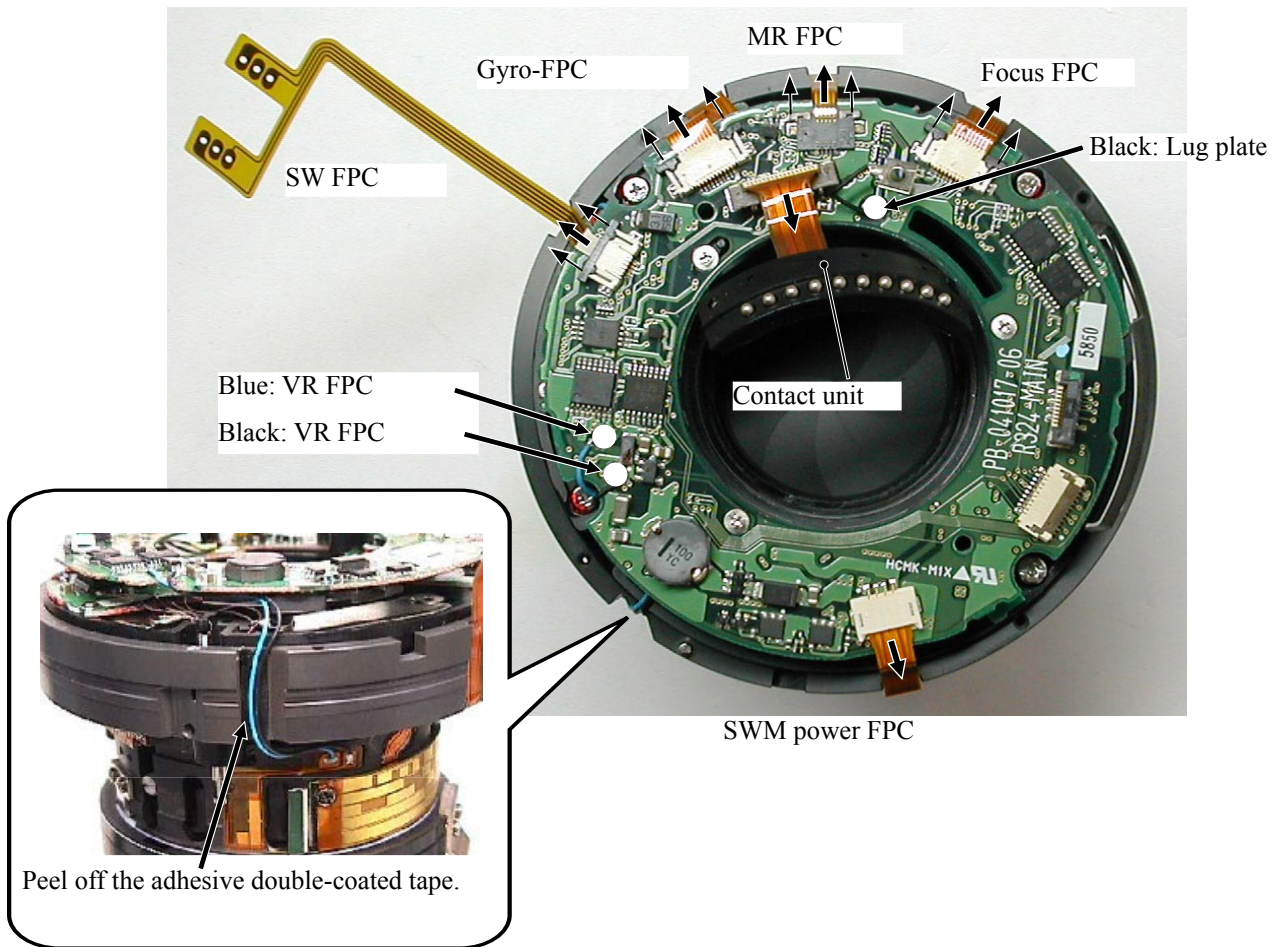

VR unit

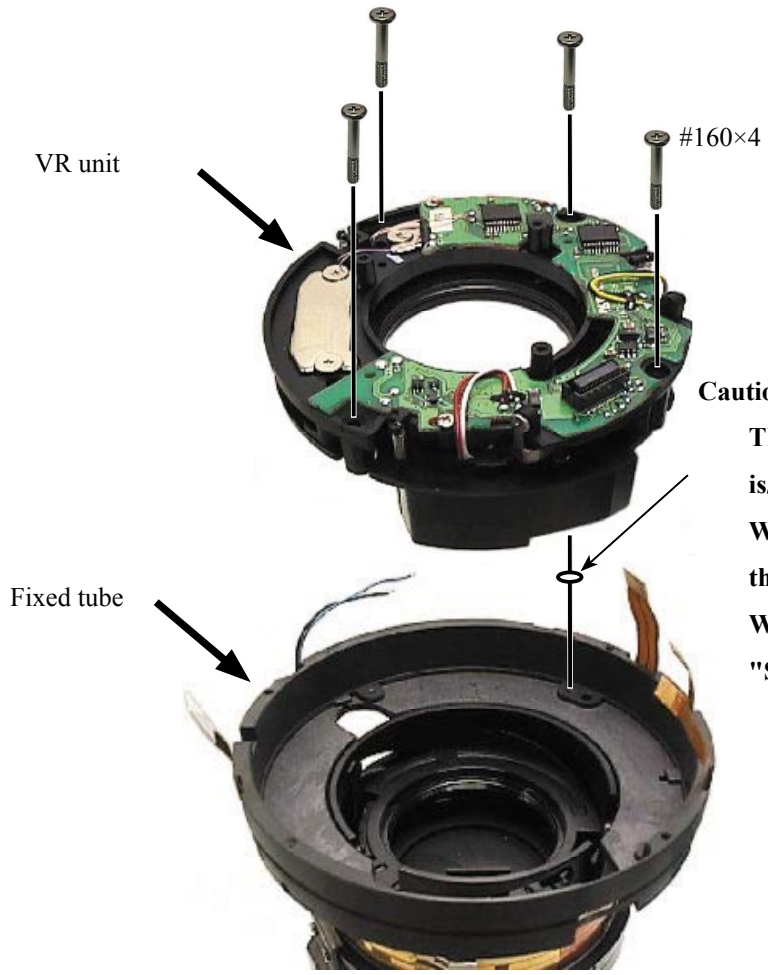

Caution:
 The washer(s) (191: selected from A ~ G) is/are put in some VR units.
 When the VR unit is NOT replaced, insert this washer as it is.
 When the VR unit is replaced, perform "Slant check of VR unit" on Page A12.

GMR unit

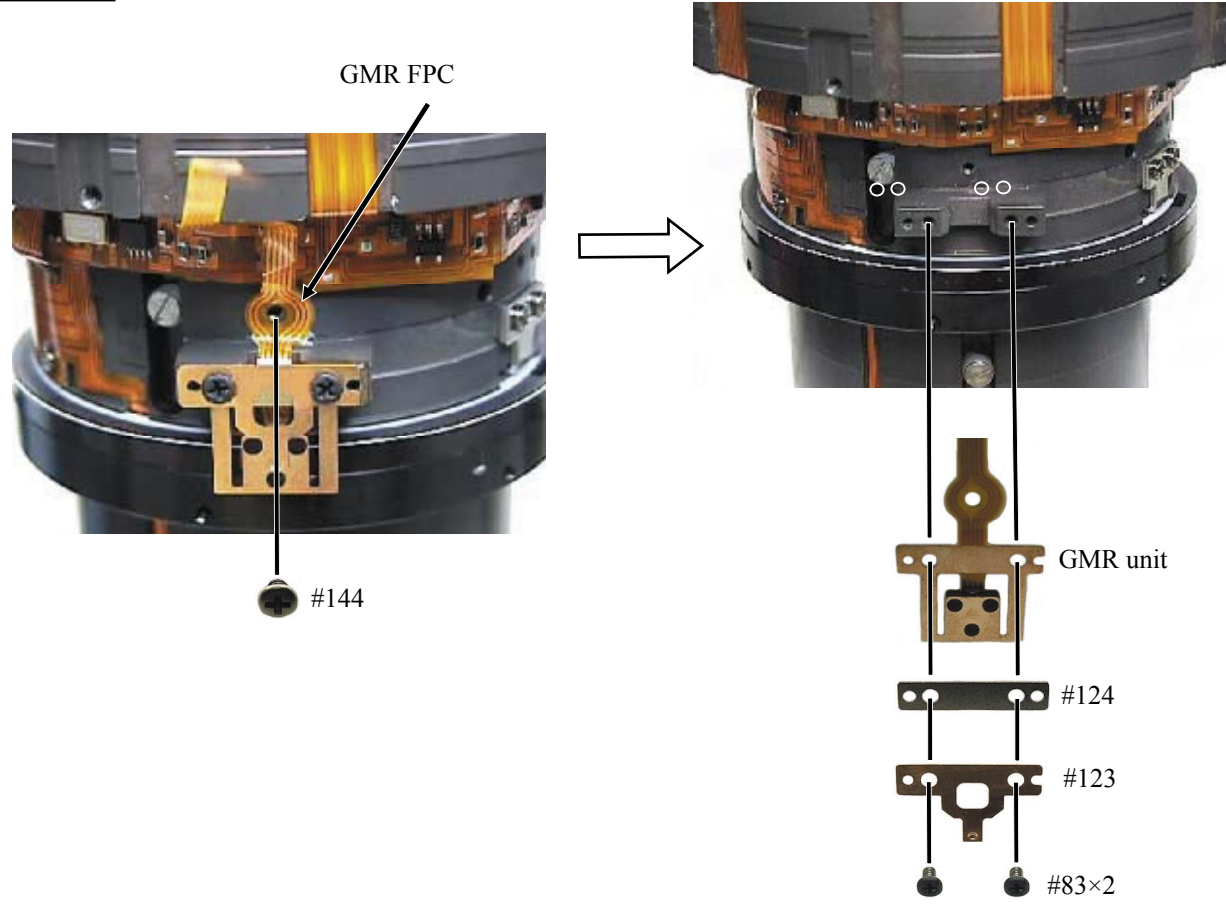

Focus coupling key

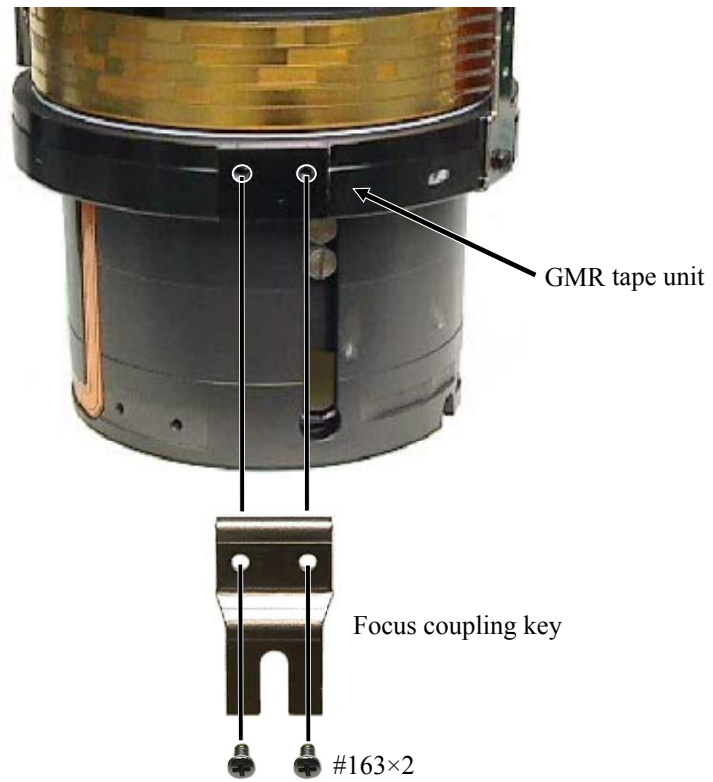

Focus brush unit



GMR tape unit

Caution 1:

Do NOT touch the tape of the GMR tape unit directly with hands.

- ① Take out the two screws (#98) through the holes of the GMR tape unit, and remove the two rollers (#99) and the two washers (#96).
- ② Rotate the GMR tape unit in the direction of the arrow "A" all the way to the limit, then remove it upwards.



Focus restriction section

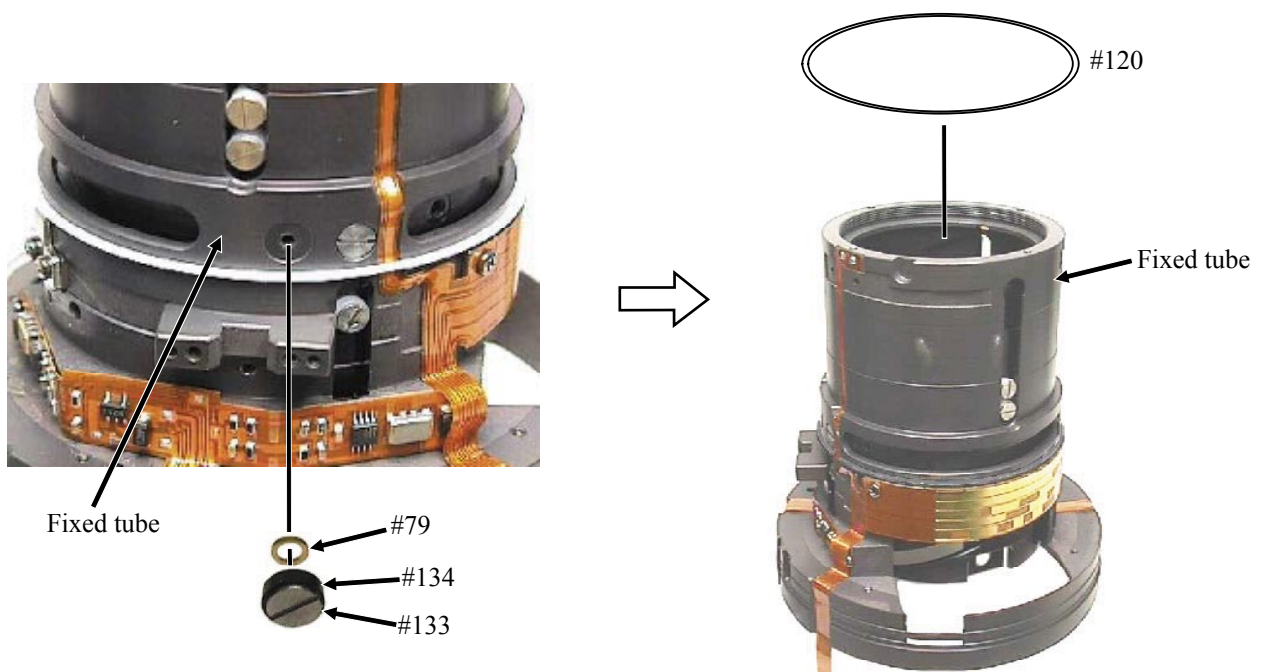

Focus FPC unit

① Peel off the focus FPC from the fixed tube.

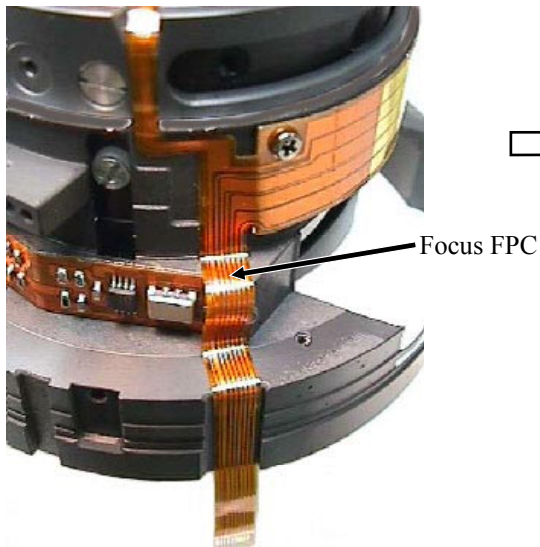

② Peel off the focus FPC from the fixed tube.

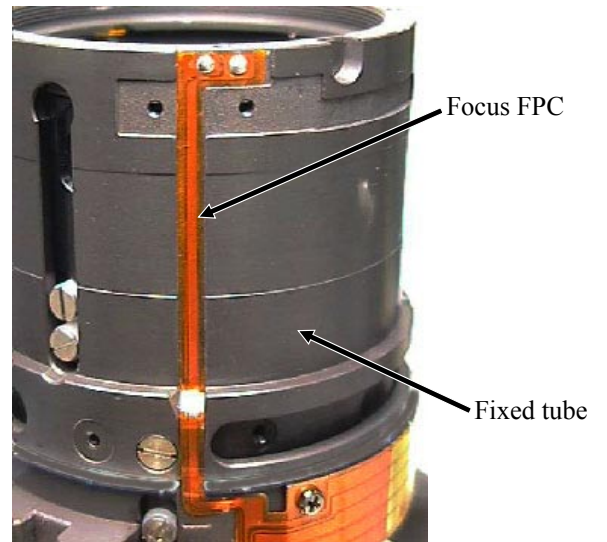

③ Take out the right-side screw (#113) of the focus FPC unit.

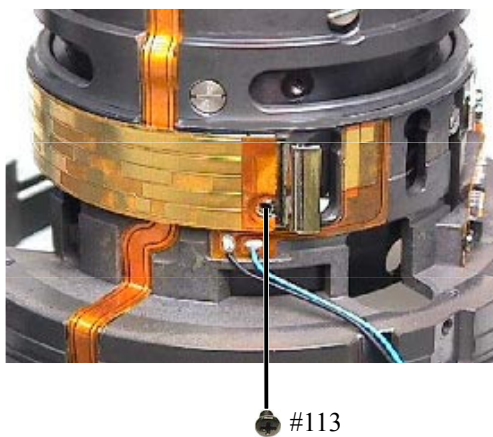

④ Take out the left-side screw (#113) of the focus FPC unit, and remove the focus FPC unit.

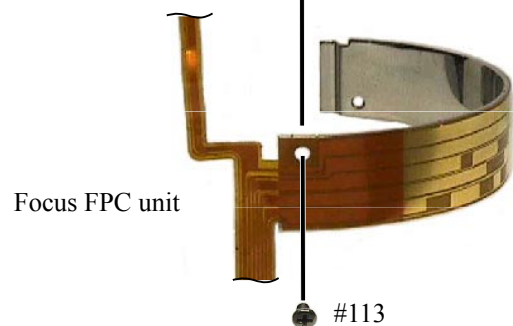
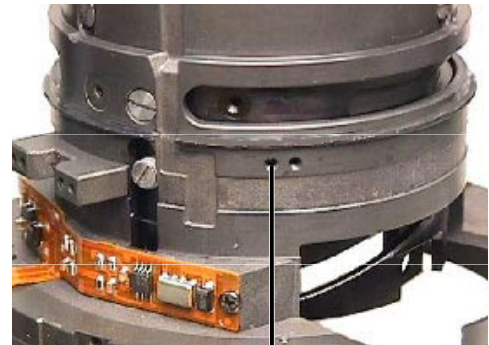

3rd lens-group movement-frame unit

- ① Rotate the cam ring in the direction of the arrow until the hole of the 3rd lens-G movement frame unit can be seen from the groove of the aperture unit.
- ② Take out the screw (#158), and remove the roller (#157A ~ D).

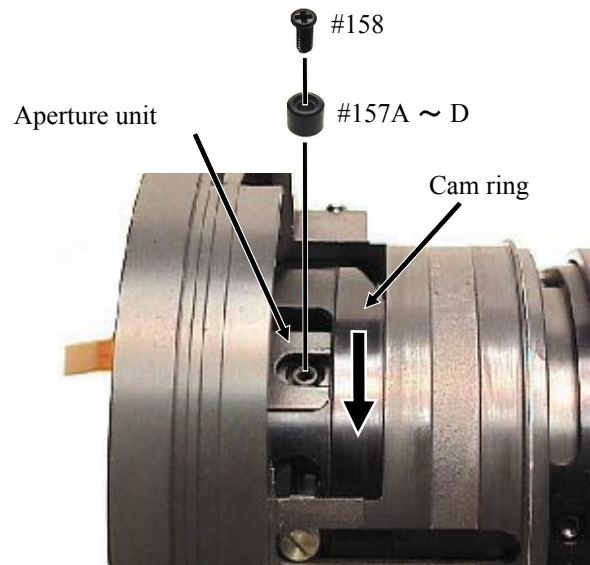

- ③ Rotate the cam ring in the direction of the arrow until the roller (B28) is positioned lowered.
- ④ Take out the three screws (#78).
- ⑤ Remove the three pairs of the roller (#77 selected from A-F) and the roller (#76 selected from A-F) with the new tool, X-type slim tweezers (★ J11326), or an equivalent tool.
- ⑥ Remove the 3rd lens-G movement frame unit.

★ New tool

- Fold the tip of the X-type slim tweezers (★ J11326) as below, and use it.

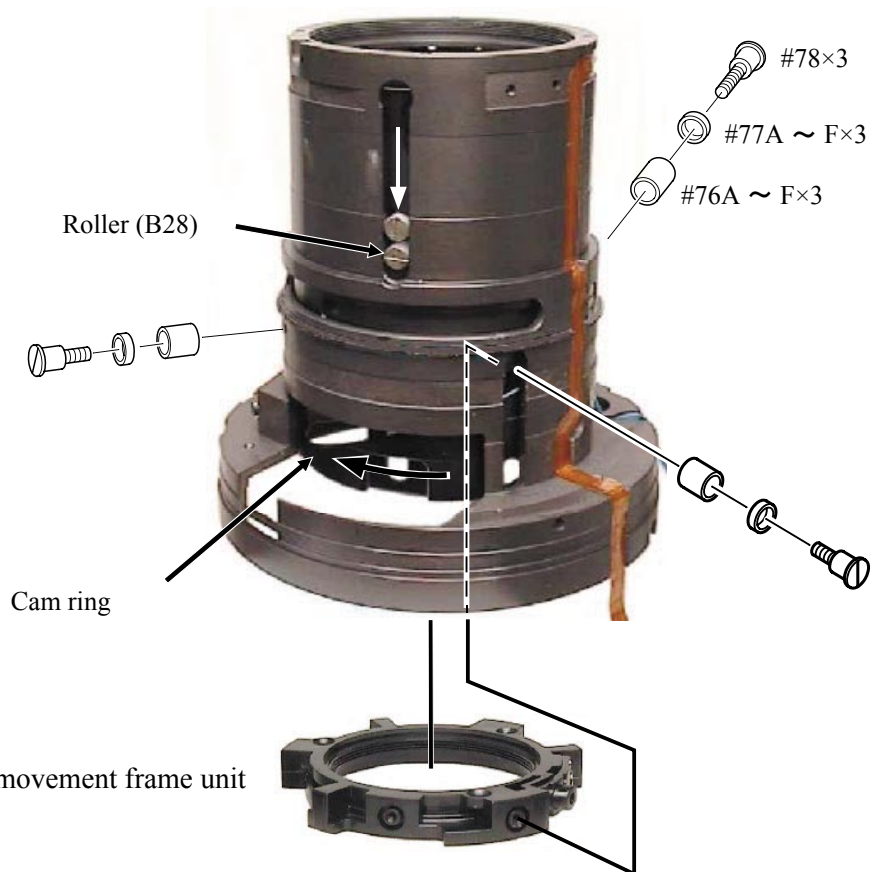
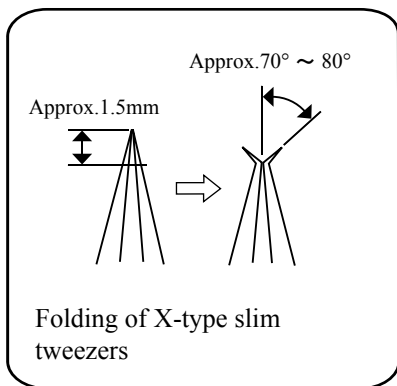

Aperture unit

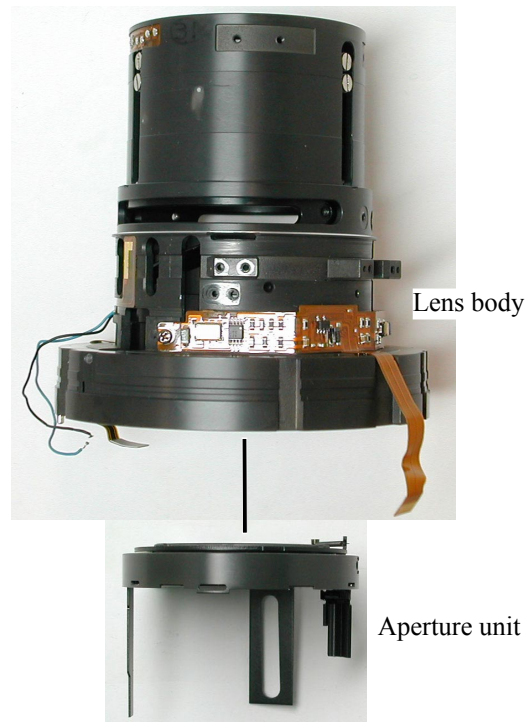
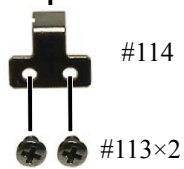
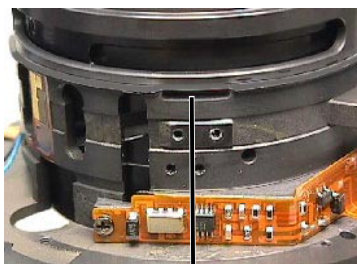
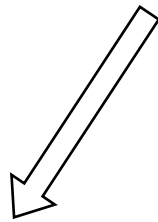
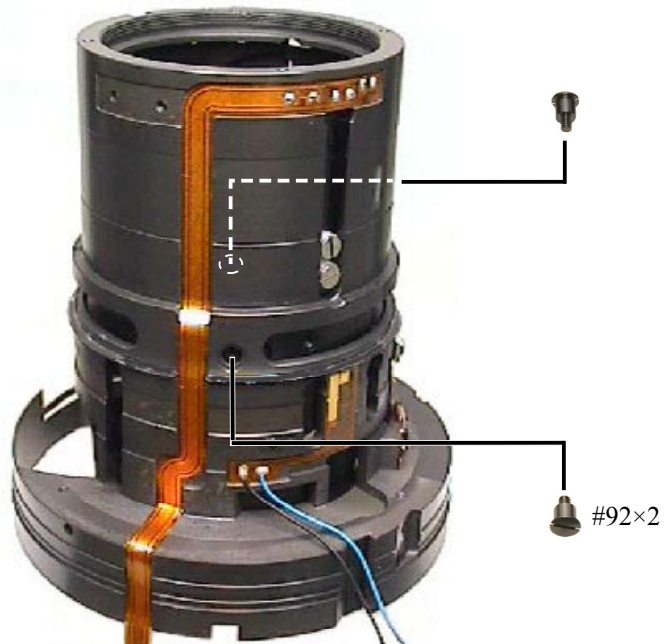

Gyro-FPC

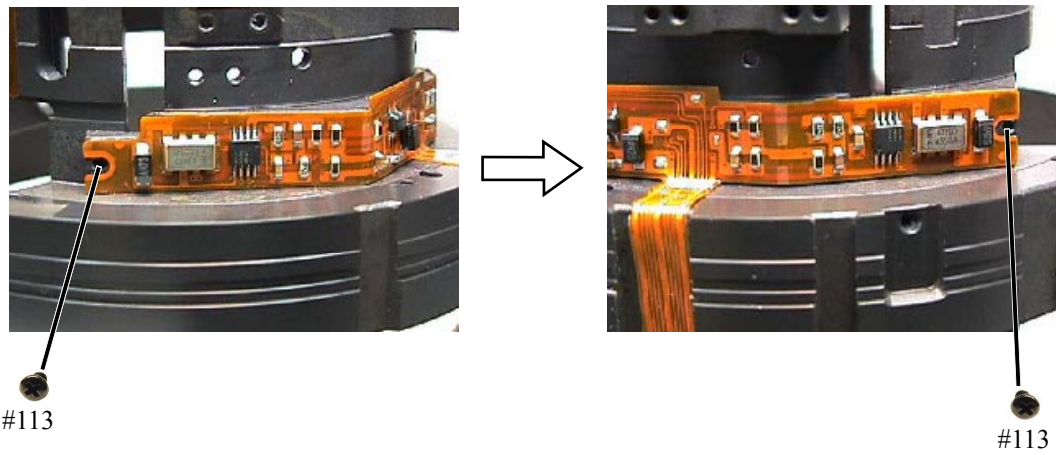

SWM power FPC

- Peel off the SWM power FPC from the fixed tube unit.
(SWM power FPC is attached with the adhesive double-coated tape.)



VR FPC

- Peel off the VR FPC from the fixed-tube unit.
(VR FPC is attached with the adhesive double-coated tape.)

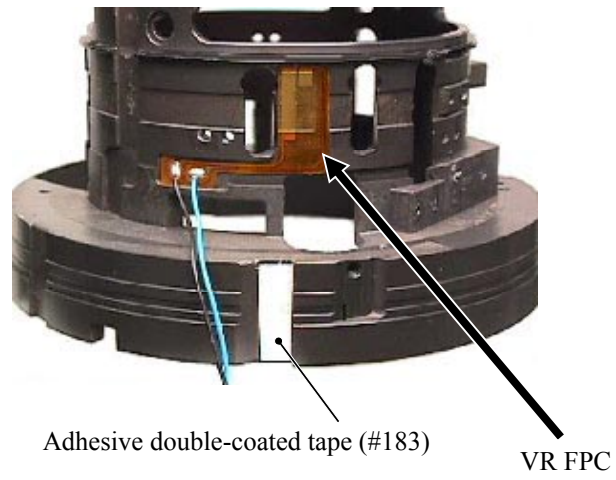

2 ASSEMBLY / ADJUSTMENT

VR FPC

- Attach the VR FPC on the fixed lens-barrel unit.
(VR FPC already has the adhesive double-coated tape adhered.)
- Attach the adhesive double-coated tape (#183) at the below position.

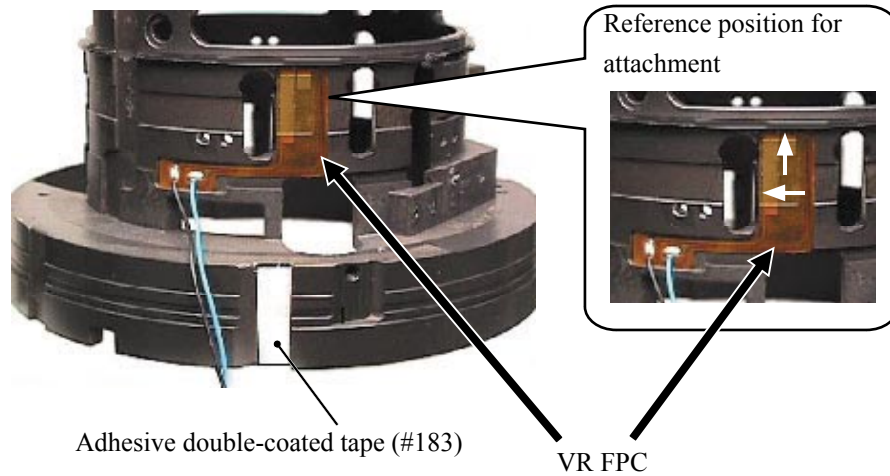

SWM power FPC

- Attach the SWM-power FPC on the fixed lens-barrel unit.
(SWM-power FPC already has the adhesive double-coated tape adhered.)

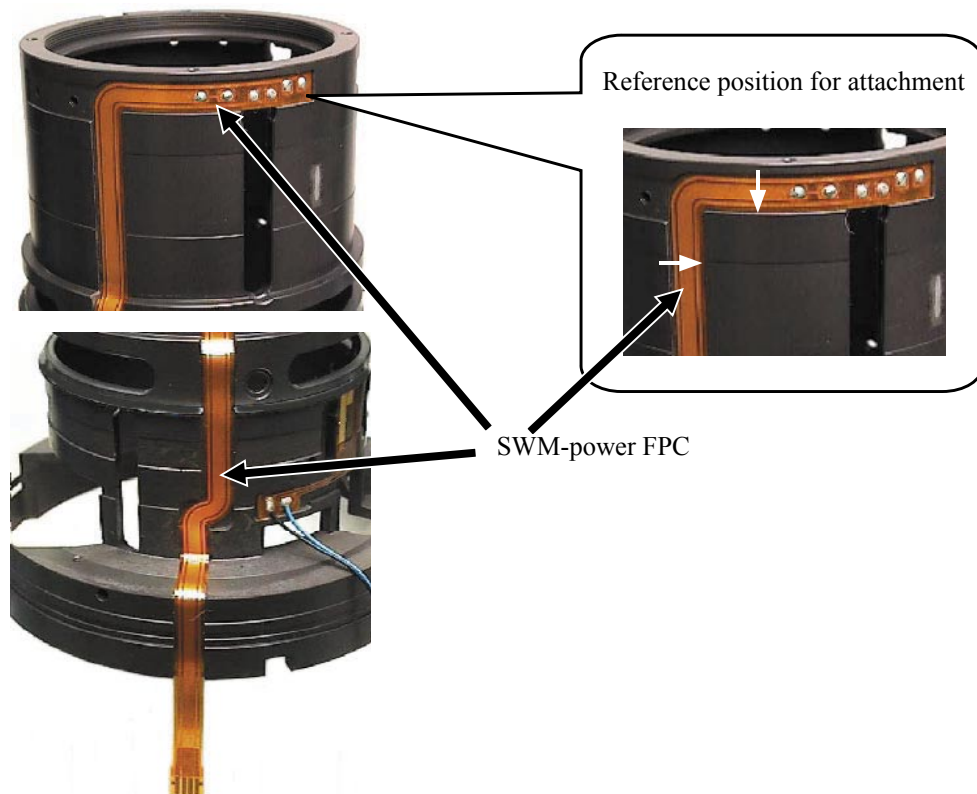

Gyro-FPC

- ① Attach the gyro-FPC on the fixed lens-barrel unit.
(Gyro-FPC already has the adhesive double-coated tape adhered.)
- ② Fix it with the two screws (#113).

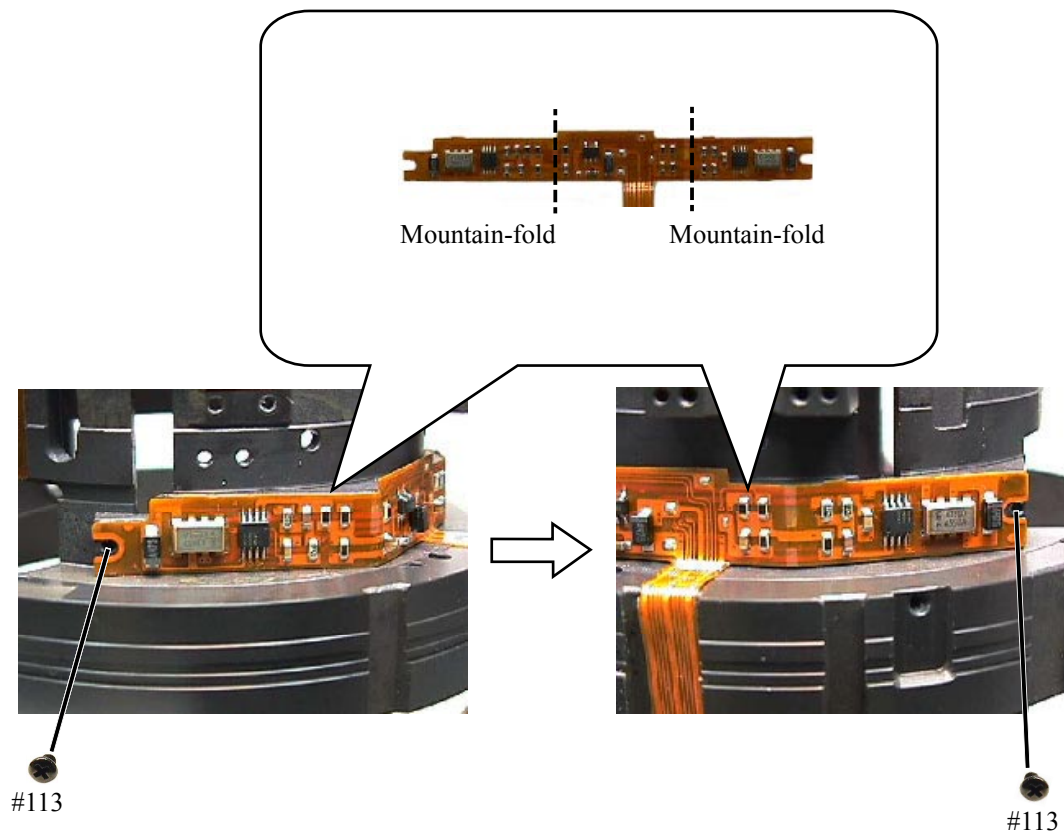

Aperture unit

- ① Align the grooves of the aperture unit and the lens body, and assemble them.

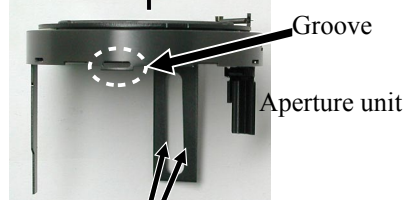
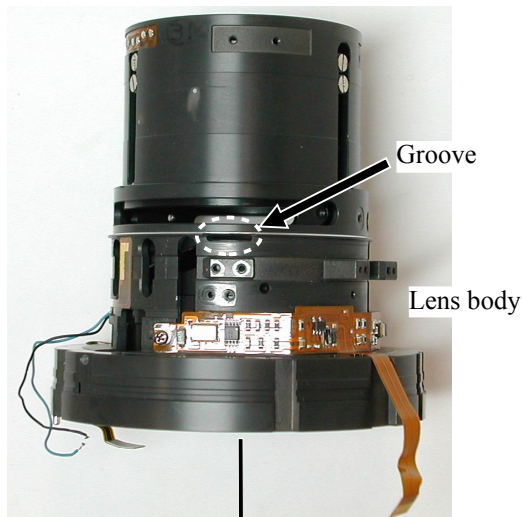

Grease: G92KA
Apply to groove.

- ② Set the key (#114) by fitting its upper part in the groove of the aperture unit. Then fix it with the two screws (#113).

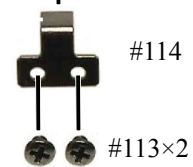
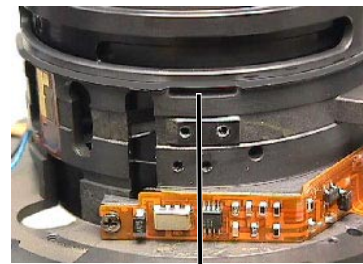

Adhesive: Lockend B

- ③ Fix the aperture unit with the two screws (#92).



3rd lens-group movement-frame unit

- ① Rotate the cam ring in the direction of the arrow until the roller (B28) is positioned lowered.
- ② Put the 3rd lens-G movement-frame unit inside the cam ring as shown below.
- ③ Fix three pairs [of the roller (#76 selected from A-F) and the roller (#77 selected from A-F)] with the three screws (#78).

Caution: Choose rollers (#76 and #77) which are slightly tight for each groove.

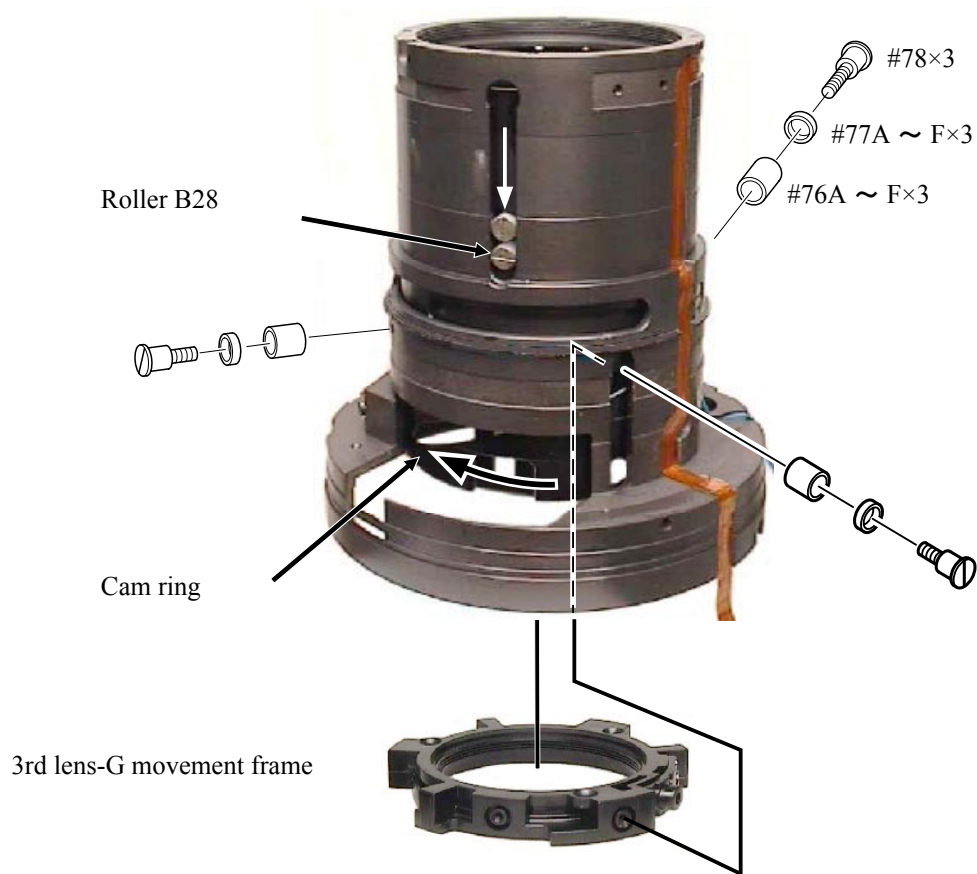

- ④ Rotate the cam ring in the direction of the arrow until the screw hole of the 3rd lens-G movement frame can be seen from the groove of the aperture unit.
- ⑤ Fix the roller (#157 selected from A ~ D) with the screw (#158).

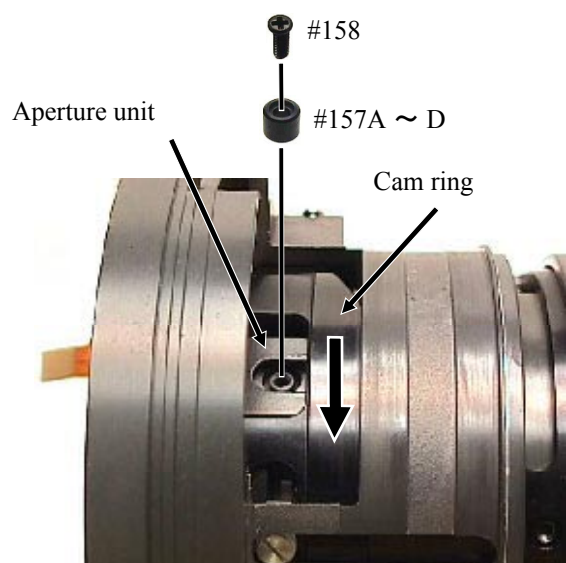

Focus FPC unit

- ① Fix the left side of the focus FPC unit with the screw (#113).

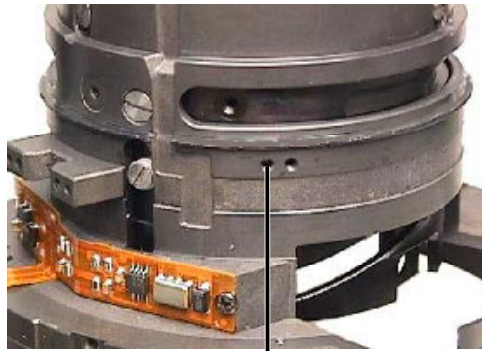

- ② Tighten the right side of the focus FPC unit with the screw (#113) temporarily.

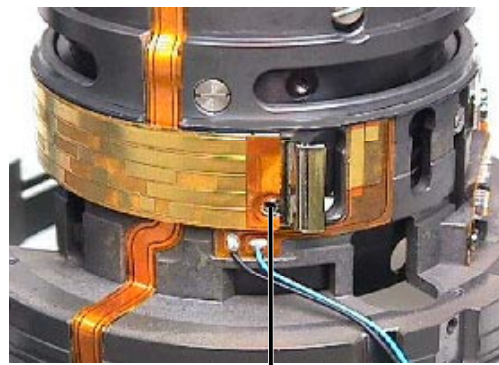

#113
Tighten temporarily

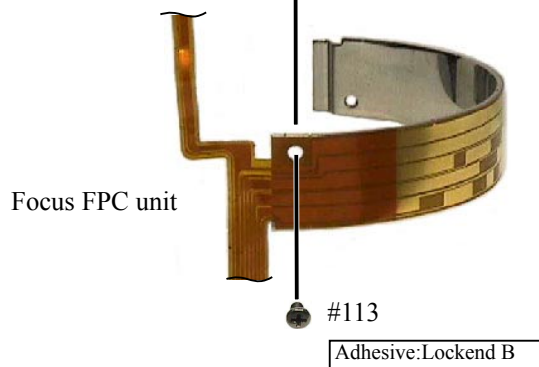

- ③ Attach the focus FPC on the fixed tube, according to the reference position.

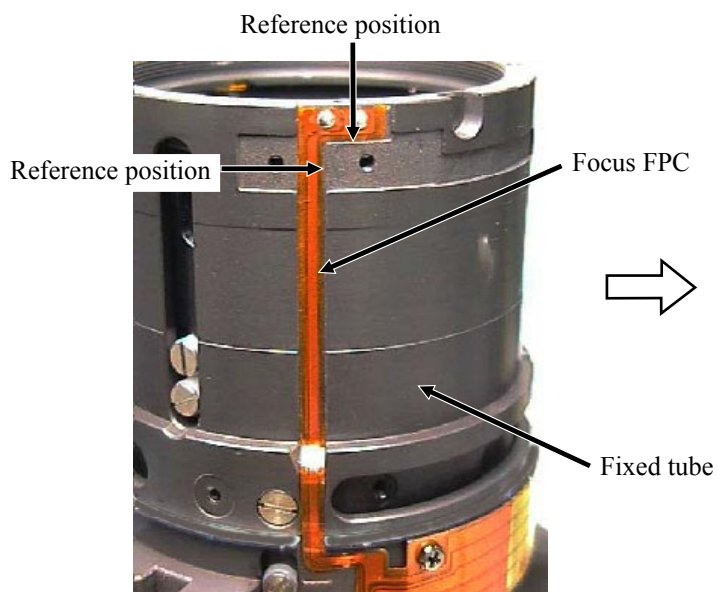

- ④ Attach the focus FPC by conforming to the shape of the fixed tube.

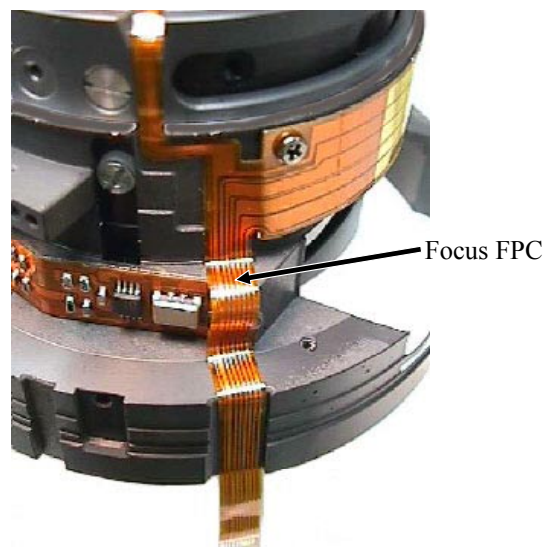

Focus restriction section

① Assemble the teflon sheet (#120) in the fixed tube.

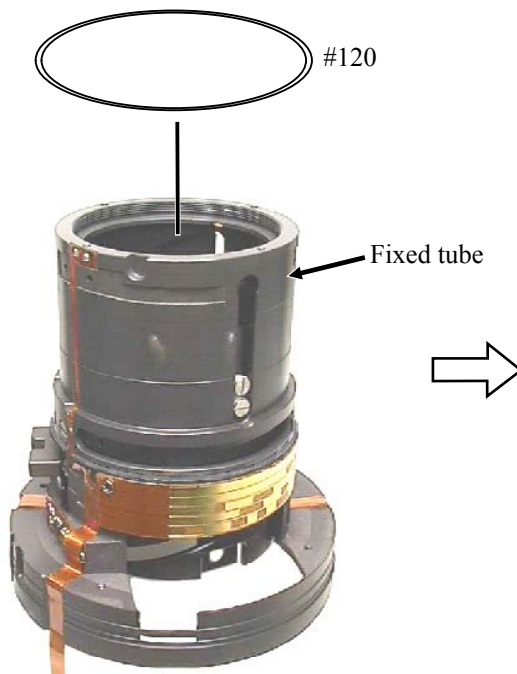

② Fix the restriction rubber (#134) and the washer (#79) on the fixed tube with the screw (#133).

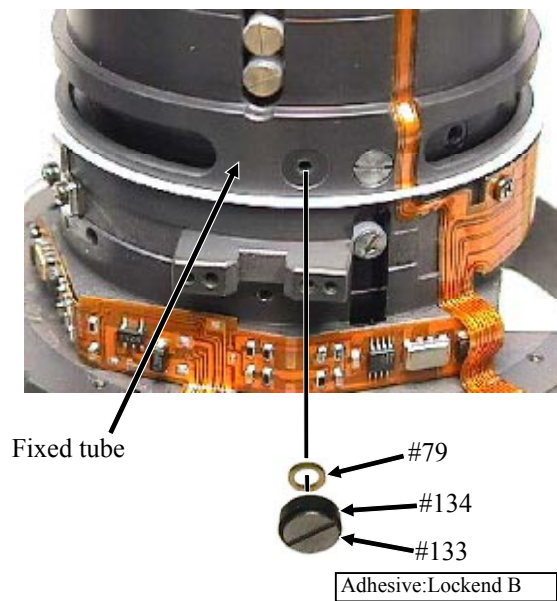

GMR tape unit

Caution 1:

Do NOT touch the tape of the GMR tape unit directly with hands.

Caution 2:

The ball-bearing visible side of the roller (#99) must come to the washer (#96)-side.

Caution 3:

The chamfered side of the washer (#96) must come to the roller (#99)-side.

① Align the concave portion of the GMR tape unit with the focus restriction portion, then assemble the GMR tape unit into the fixed tube.

② Fix each two pairs [roller (#99) and washer (#96)] with the screws (#98) by passing the body of the screws (#98) through the holes of the GMR tape unit.



(Focus) Encoder brush unit

- ① Fix the encoder brush unit on the GMR tape unit with the screw (#83) temporarily.

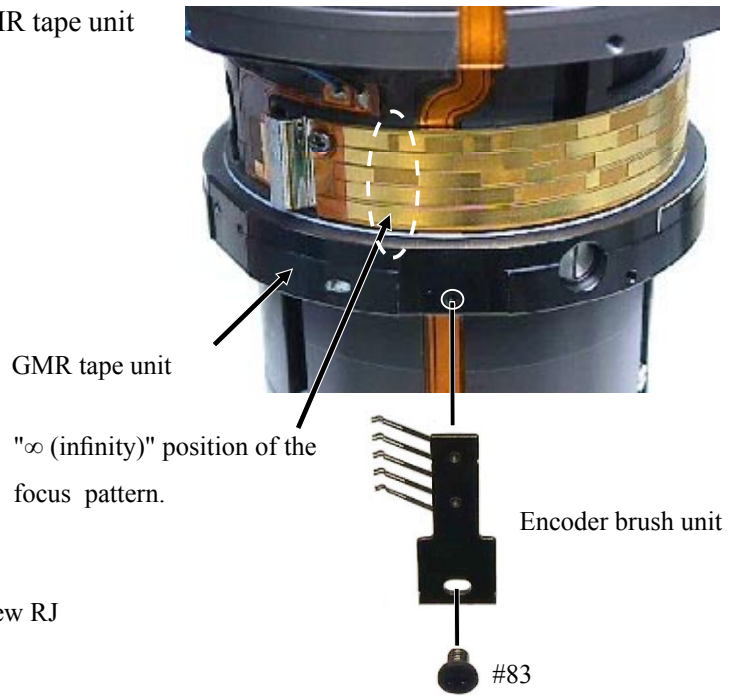

- ② Rotate the GMR tape unit until the "A" hole is aligned with the "∞" hole of the inner cam ring of the fixed tube.
- ref : The above position of "∞" hole of the cam ring is almost at the place where the brushes are positioned at "∞" of the focus pattern.

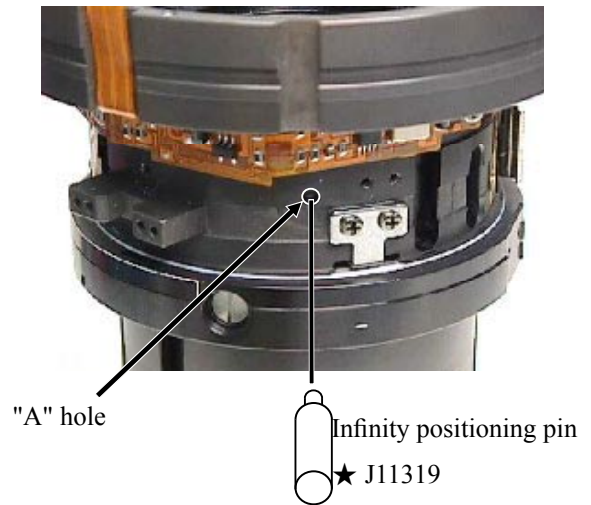

- ③ Insert the tool (★ J11319) in "A" hole.
- ④ Loosen the screw (#83) and move the encoder brush unit from side to side. Adjust so that the contact surface of the brush is at "∞" position of the focus pattern.
- ⑤ Tighten the screw (#83) and apply the screwlock.
- ⑥ Remove the tool (J11319) from "A" hole.

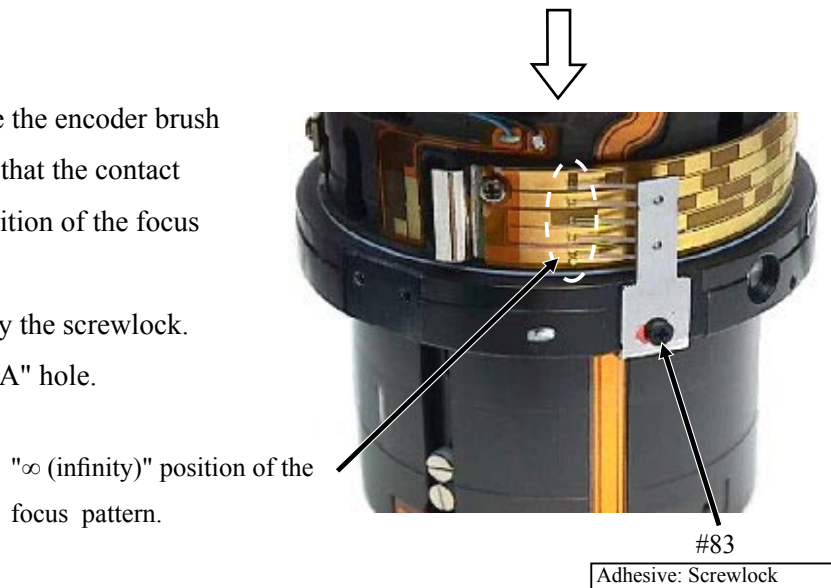

Focus coupling key

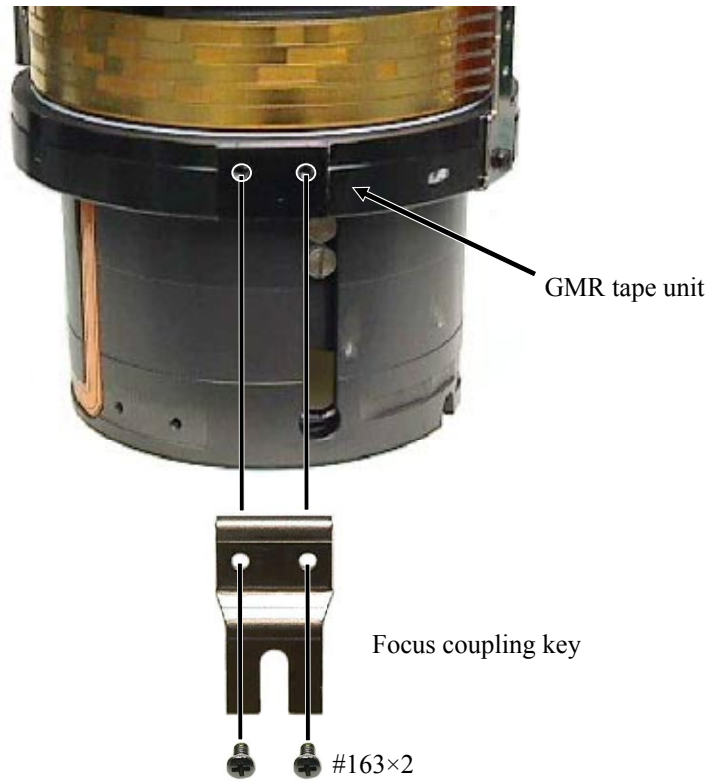

GMR unit

Adhesive: Lockend B

Tool-pin hole

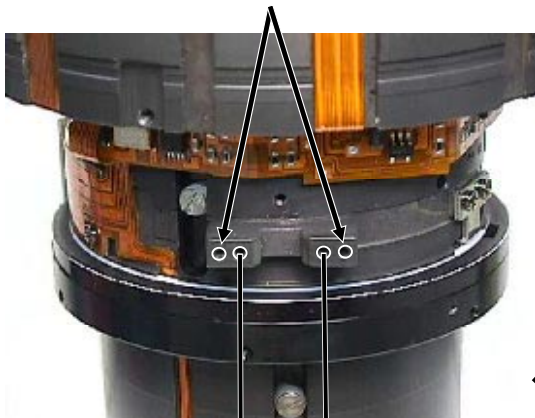

- ① Insert the drill with $\phi 1.2$, etc into the two tool-pin holes.
- ② Fix the GMR unit, retaining plate (#124), and GMR-retaining plate spring (#123) with the two screws (#83).
- ③ Fix the GMR FPC with the screw (#144).

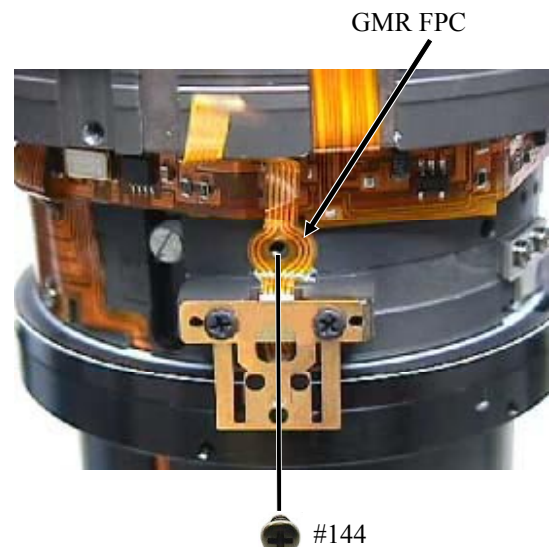
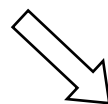
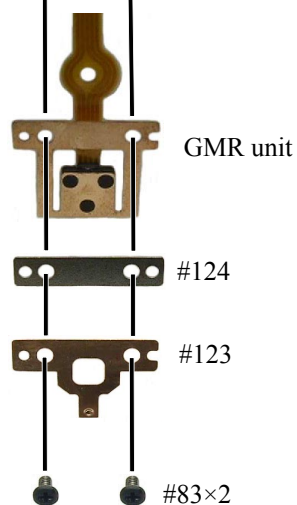

MR encoder output-waveform inspection

- When the GMR unit is disassembled and replaced, be sure to make an adjustment.

1. Device:

- Single-output rated voltage power-supply 1 unit: 5V 100mA
- Oscilloscope 1 unit
- Self-made tool 1 unit

Caution:

If there is a problem with continuity between the contacts of the self-made tool and the relay FPC, the contacting surface of the relay FPC may be dirty, eroded, or oxidized. So polish the contacts and connect them.

2. Preparation of the lens for measurement

- Assemble the MR-head-attached zoom index ring unit, the SWM, and the MF ring into the lens body. Then connect the assembled lens to each measuring machines as follows:

• 【Attachment diagram】

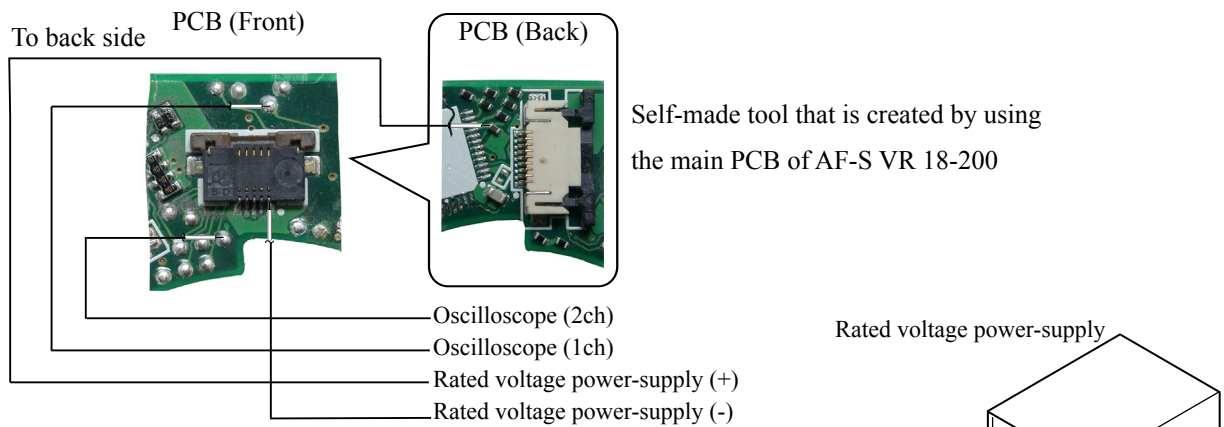

Caution:

The connector of the back of the PCB is not used.

Connect to the front-side connector of the self-made tool PCB.

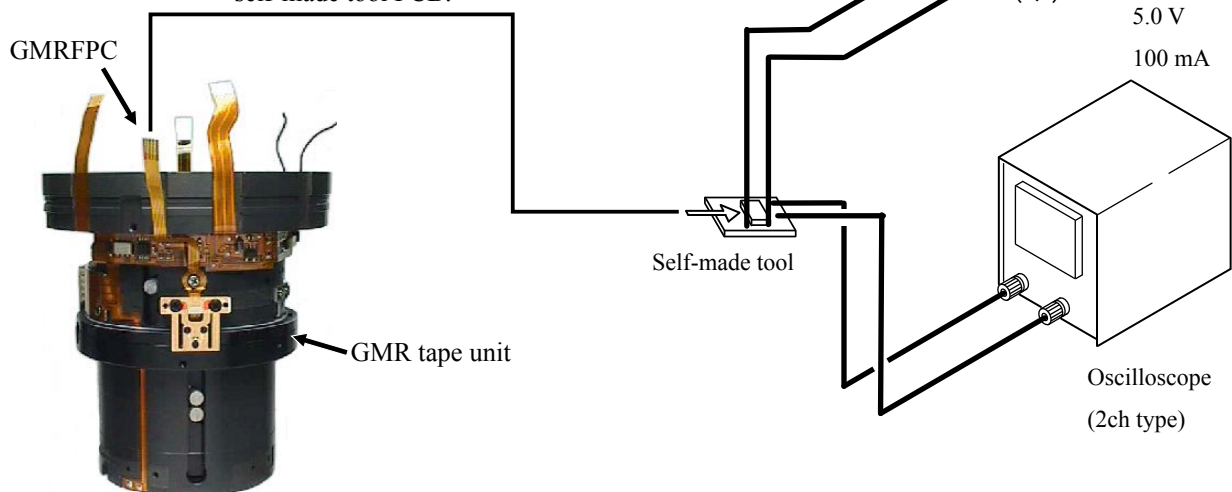

• How to inspect and adjust:

- ① Confirm that the electric current and voltage of the connected rated voltage power-supply are set values, then turn it ON.
- ② Set the oscilloscope, and turn the GMR tape unit by holding the focus coupling key.

Note: The waveform varies according to the rotational speed of the focus ring. So change “Time/Div” setting accordingly.

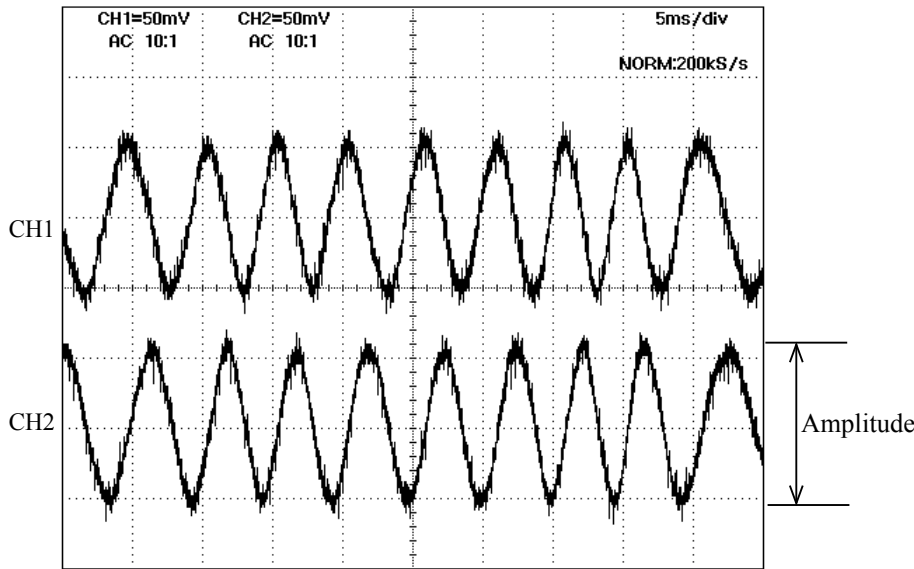

Fig. 1

- Oscilloscope setting
 - V/Div (ch1) :50 mV
 - V/Div (ch2) : 50 mV
 - Coupling : AC
 - Time/Div :5 m Sec
 - Trigger Mode :NORMAL
 - Trigger Coupling : AC
 - Trigger Source :CH1
 - Trigger Position : + 4 div
 - Trigger Type :EDGE
 - Trigger Level : 0V
 - INPUT (ch1) :AC
 - INPUT (ch2) :AC

Standard: Amplitude of all pulses/waveforms is 130 mV or more.

Note: Check the waveform by moving the focus ring back and forth from the infinity-end to the close-end positions entirely.

③ In case large waveform-noise (as shown in Fig. 1) is detected, use the FILTER function.

How to set FILTER function (e.g. DL1540 manufactured by YOKOGAWA)

1. Press the FILTER button.
2. Select “Smooth” of the menu on screen and turn it ON.

④ In case the amplitude is small, disassemble up to the stage of the GMR sensor FPC unit. Then if the deformation is detected in the MR head, correct the deform of the MR head. On the other hand, if such correction is impossible or no deformation is detected, replace the GMR sensor FPC unit. (Fig.2)

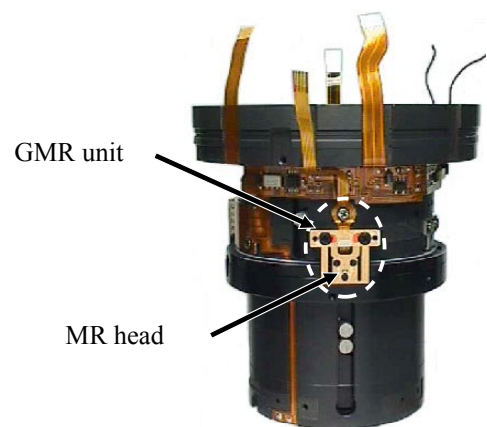

Fig.2

Note: When adjustments are made, prevent the magnetic surface and MR head from touching the magnetized driver bit. Otherwise, the magnetic data may be damaged.

< Ref. >

- As shown in Fig. 3, if the amplitude of only either CH1 or CH2 is small, one of the 2 screws (#123) may be loosened, so check for it. If this is not the case, the MR head may malfunction, so replace the GMR sensor FPC unit and make a readjustment.

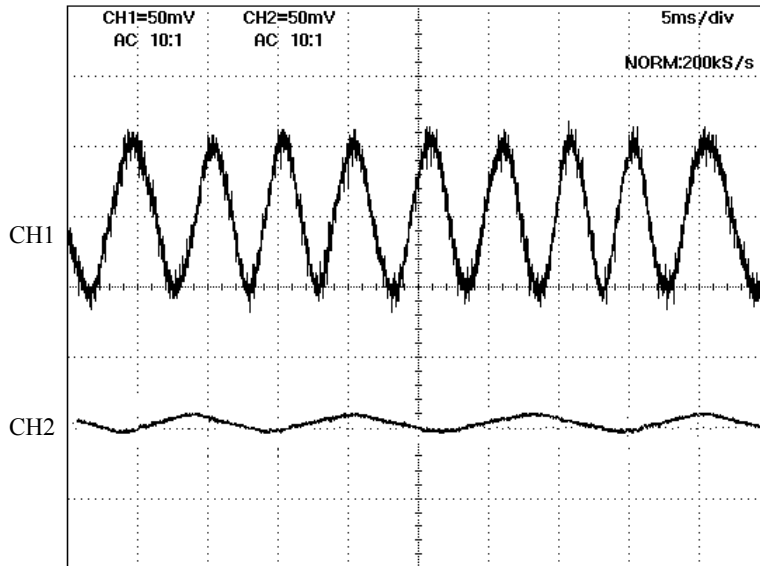

Fig. 3

- As shown in Fig. 4, if the amplitude partially drops between the infinity and the close-distance, the magnetic data of the tape may be damaged. So replace the main fixed tube unit and make a readjustment. Replacing only the magnetic surface is impossible.

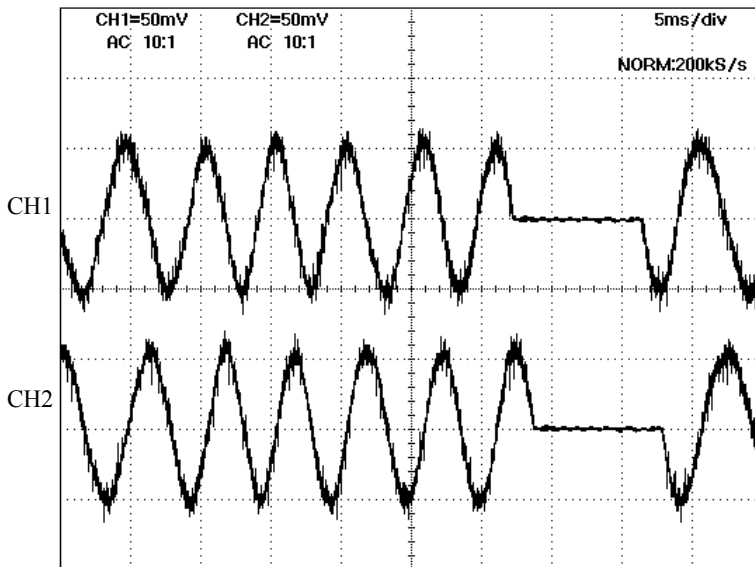

Fig. 4



GMR tape unit

- ⑤ Turn off the rated voltage power-supply.



VR unit

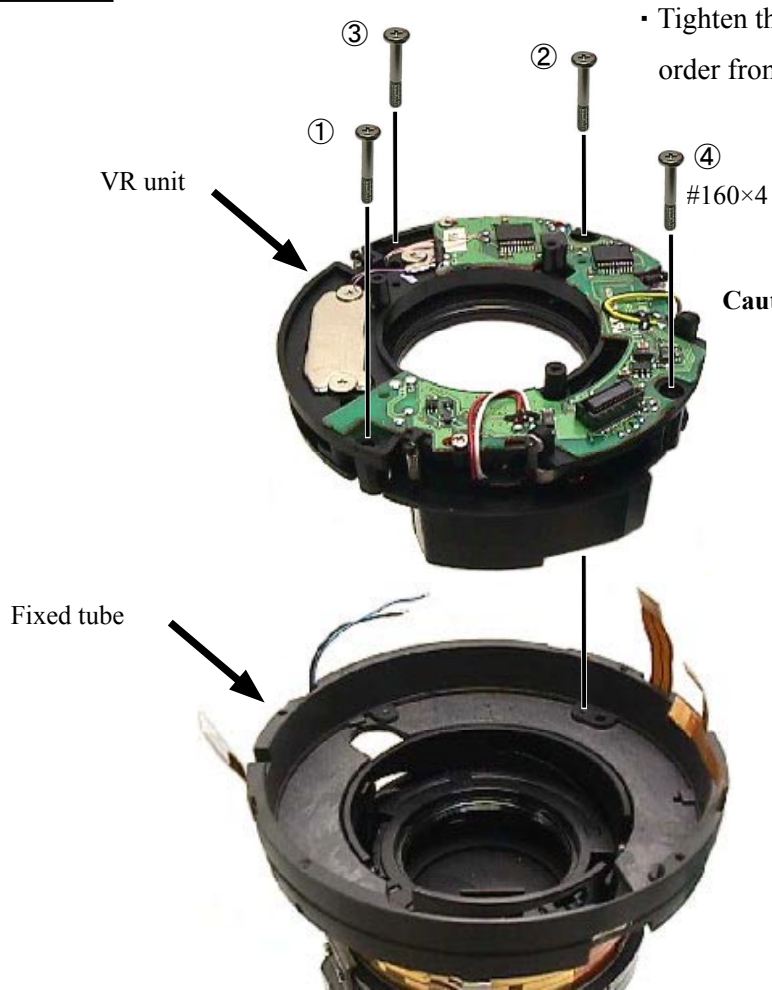

• Tighten the four screws (#160) in the order from ① to ④.

Caution:

The washer(s) (191: selected from A ~ G) is/are put in some VR units.

When the VR unit is NOT replaced, insert this washer as it is.

When the VR unit is replaced, perform "Slant check of VR unit" on the next page.

Slant check of VR unit

★ New tool

★ J11321

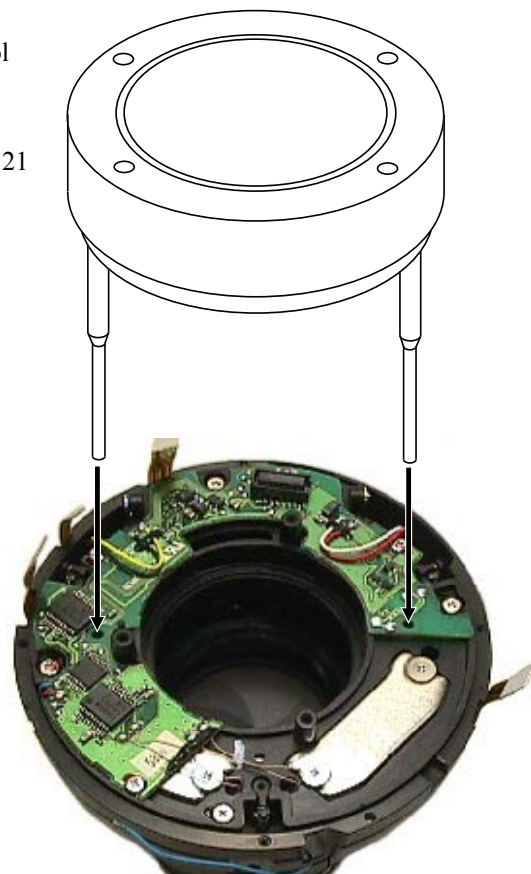

① Mount the VR fixing tool (★ J11321) by fitting in the holes of the VR unit.

- ② Mount the VR mirror tool (★ J11330) on the VR unit with the mirror-assembling tool (★ J11331). ★ New tool
- ③ Remove the VR-fixing tool (★ J11321).

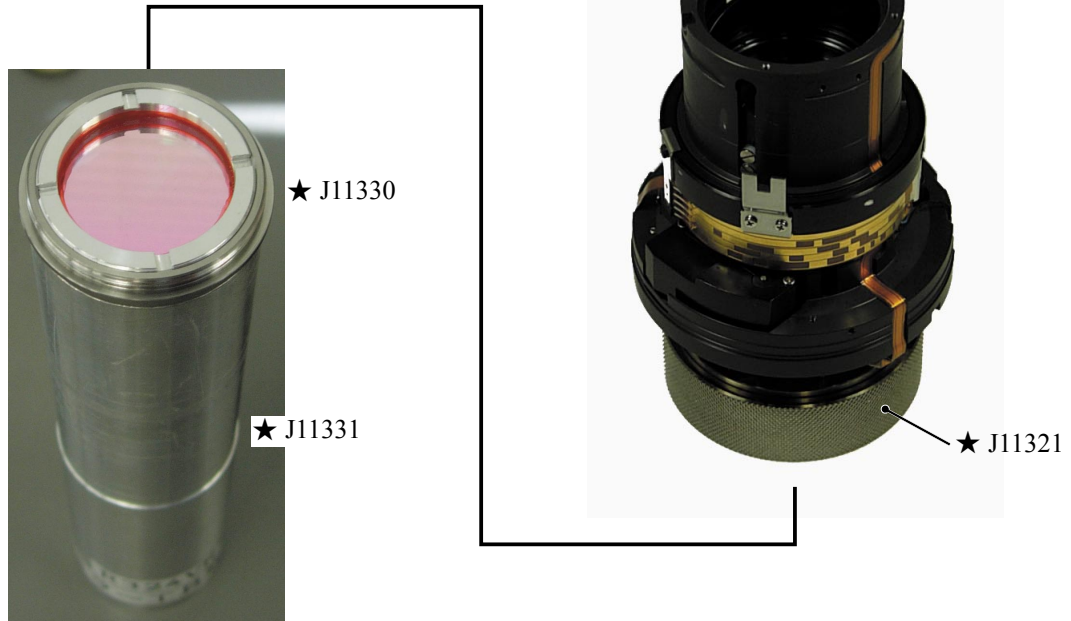

- ③ Place a parallel glass or parallel mirror, etc, on the measurement stand.
- ※ For a parallel glass, a super telephoto, G1 lens, such as AF-S300 mm can be used, while for a parallel mirror, the main-mirror 45-degree positioning tool, etc, can be used.
- ④ Fine-tune the position of the auto collimator, and perform the optical axis alignment with the measurement stand.

Parallel glass, parallel mirror, etc

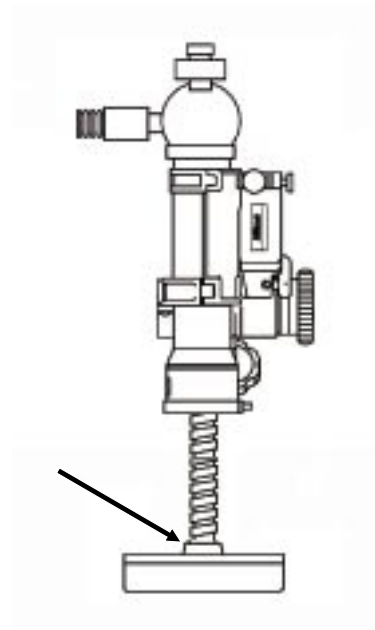

- ⑤ Remove the parallel glass which was placed on the measurement stand. Set the fixed tube as shown in the right picture.

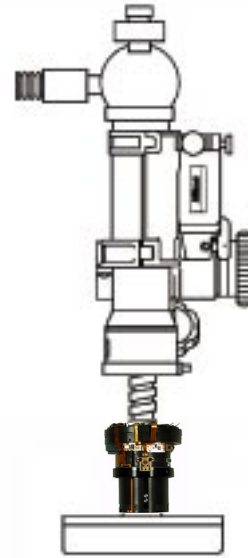

- ⑥ As shown in the right picture, measure a position difference of the cross lines, which are indicated by the mirror tool and the collimator.

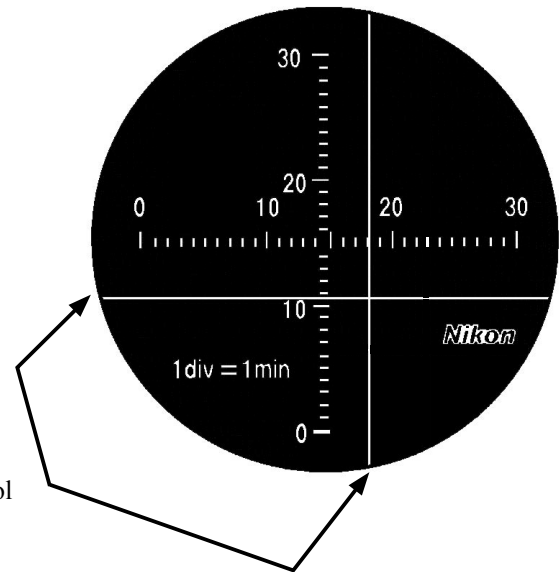

Cross lines of the mirror tool

- Tighten the four screws (#160) in the order from ① to ④ .

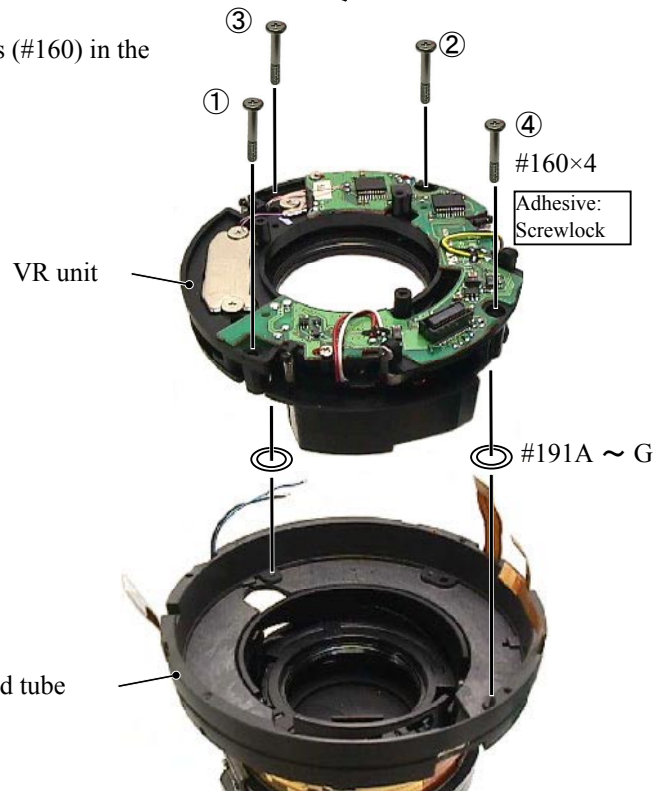

- ⑦ If the above difference is 4 min or more, select and put the washer (#191A ~ G) in order to correct the slant.

- ⑧ Remove the mirror tool after the adjustment.

Main PCB unit

- ① Connect the connector of the main PCB to the connector of the VR unit.

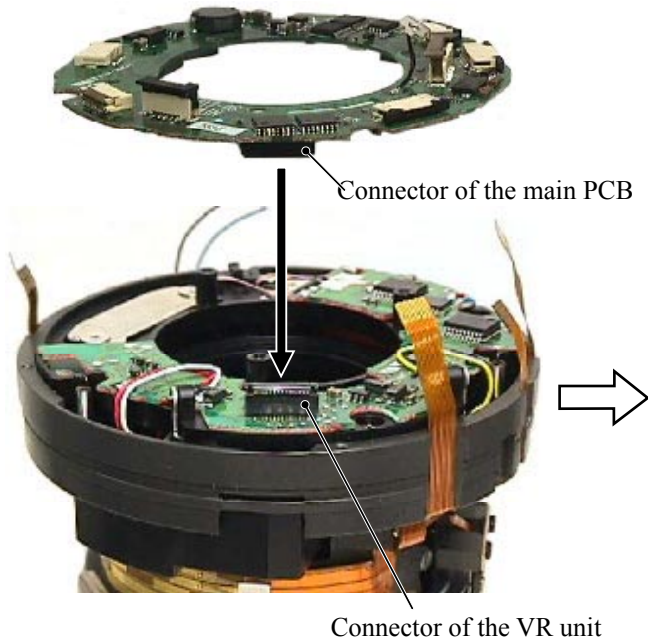

- ② Fix the main PCB with the three screws (#140).



- ③ Solder the two wires and the lug plate.

- ④ Connect the gyro-FPC, MR-FPC, SW-FPC, focus-FPC, SWM power-FPC, and the contact unit to each connector.

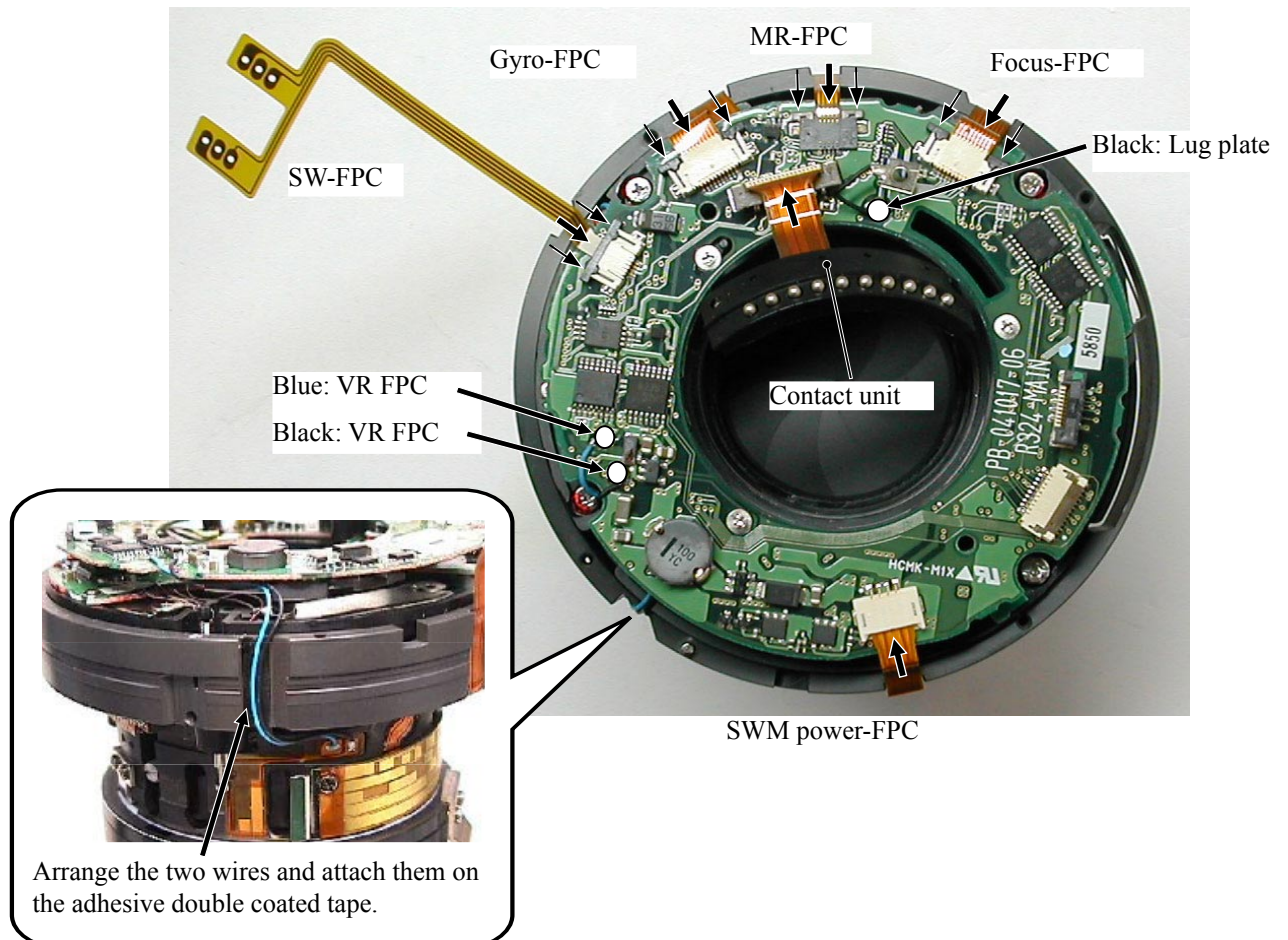

Mechanical-coupled block

- ① Take out the setscrew (#113) of the focus-FPC, and attach the mechanical-coupled block by fitting the coupling pin in the concave portion of the mechanical-coupled block.

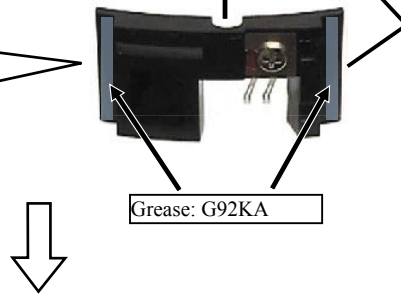
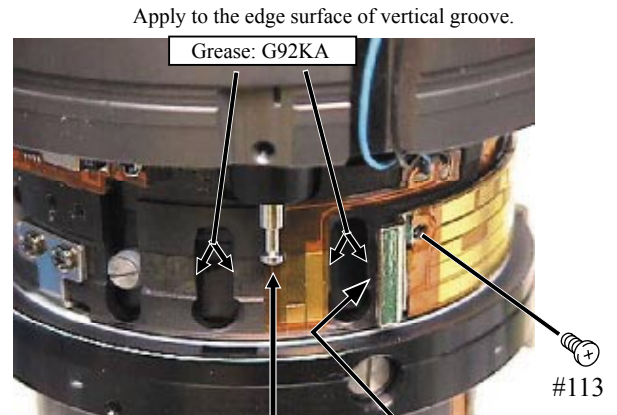
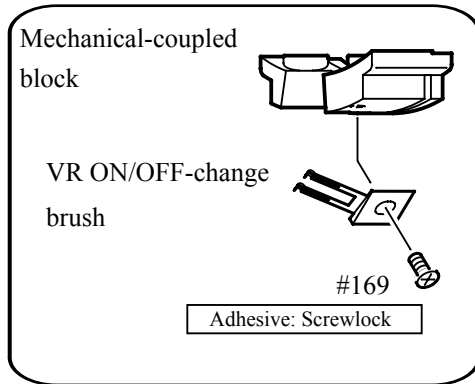

- ② Attach the block retaining plate (#184), and fix it with the two screws (#113).

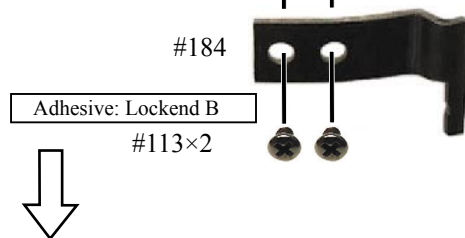
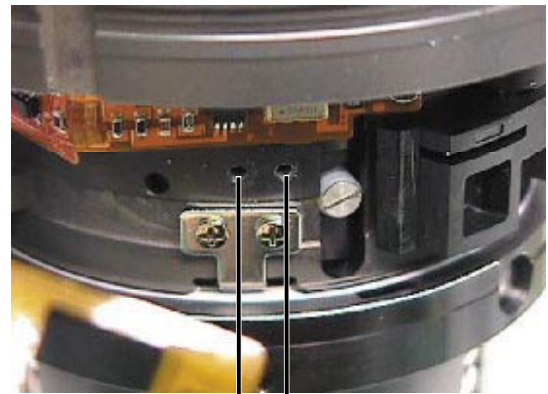

- ③ Attach the screw (#113) that was taken out in ①.



Rear outer tube unit

① Insert the positioning pin (#97).

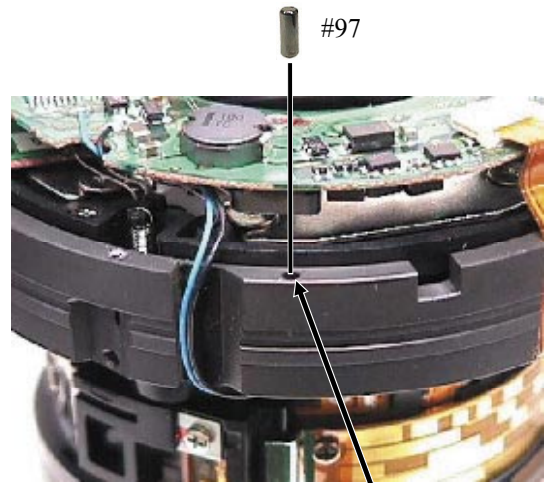

Adhesive: Lockend B
Apply to the hole.

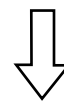

Adhesive: Lockend B
#154×4

② Mount the rear outer tube unit, and tighten the four screws (#154).

Rear outer tube unit



③ Press the lug plate towards the direction of "A", and fix it with the screw (#144). (ref. Fig. 1)

Apply to the overall circumferential surfaces of the level difference.

Grease: OS-30MF

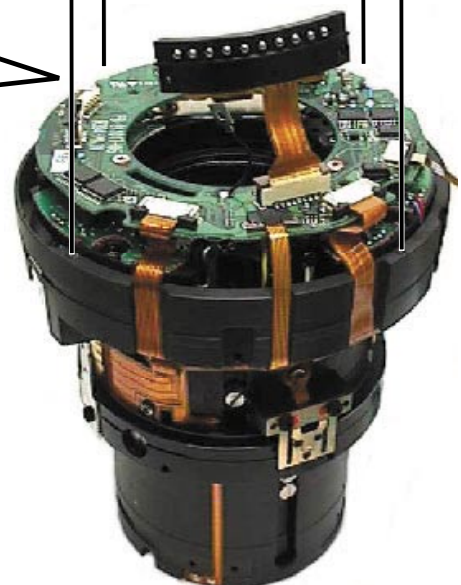

Caution:

If the lug plate is tilted when attached, the 5th lens-G alignment becomes impossible. Therefore, attach so that the lug plate is parallel to the wall of the rear outer tube unit.

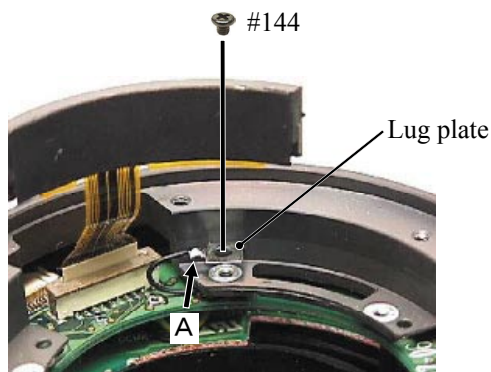
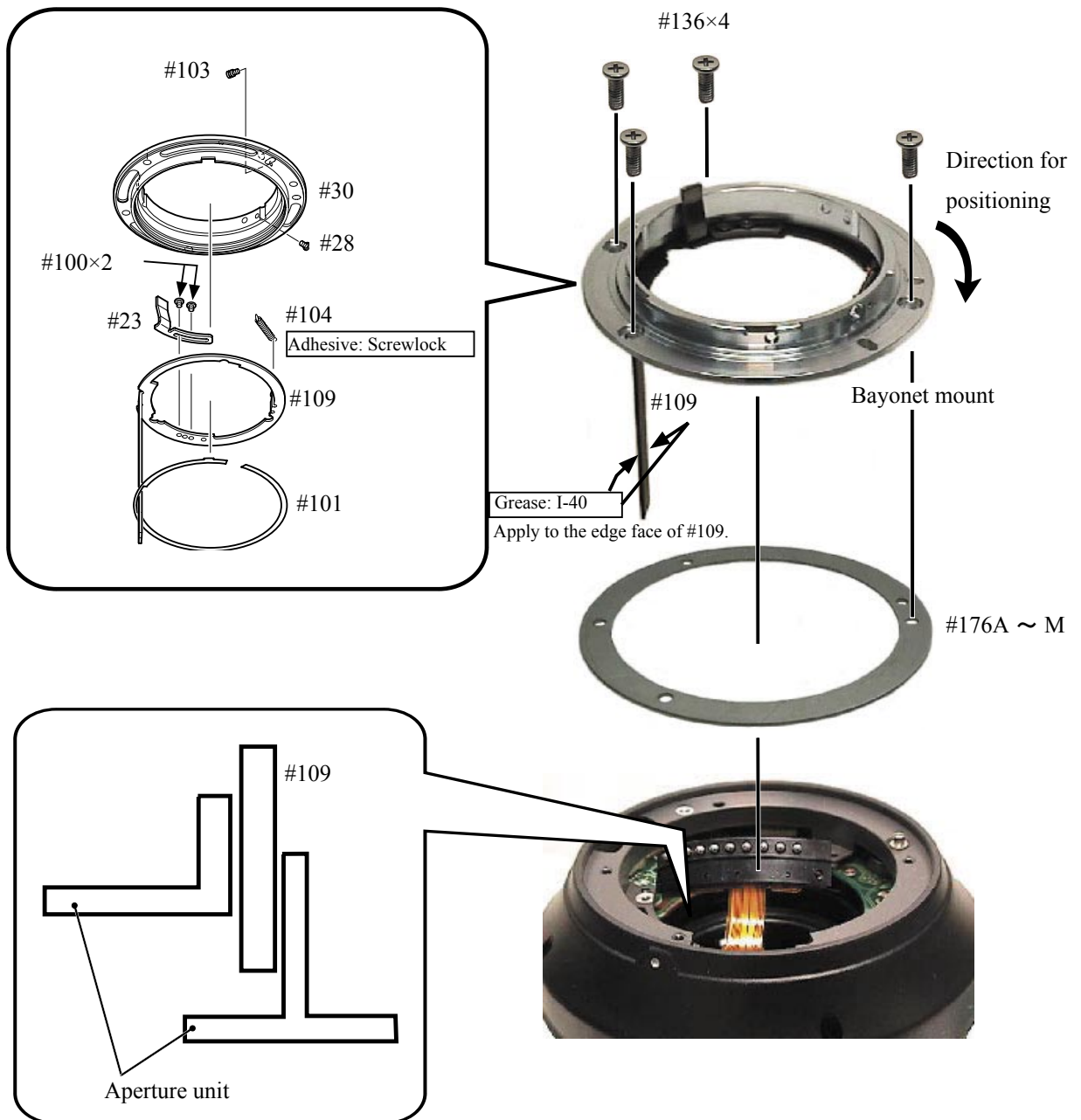

Fig. 1

Bayonet mount (temporary attachment)

- ① Put the washer(s) (#176 selected from A-M) by fitting position of the holes.
- ② Insert the aperture lever (#109) of the bayonet mount into the aperture unit by fitting in the bending part of the aperture unit.
- ③ Fix the bayonet mount with the four screws (#136) (temporarily).



Position adjustment of Aperture lever

- ① Rotate the focus coupling key in the direction of the arrow all the way J18004-1 to the limit. (close-end)
- ② Mount the tool (J18004-1). Check the aperture diameter by looking through at the aperture from the opposite side from the bayonet.

Standard (close-side): The remaining aperture blades that can be seen must be approx. 2 or 3 mm

- ③ In case the result is out of standard, rotate the focus coupling key to the infinity, loosen the screw (#74), and adjust by moving the [#61] from side to side.

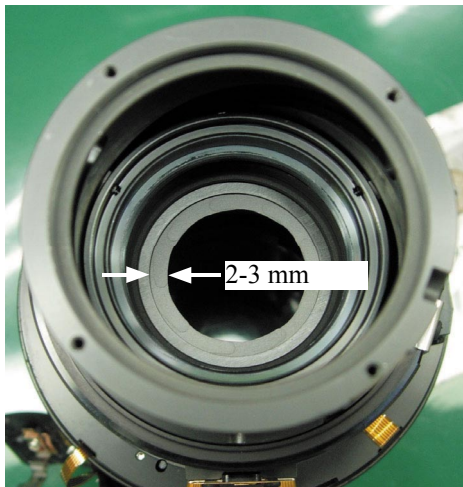

Focus coupling key

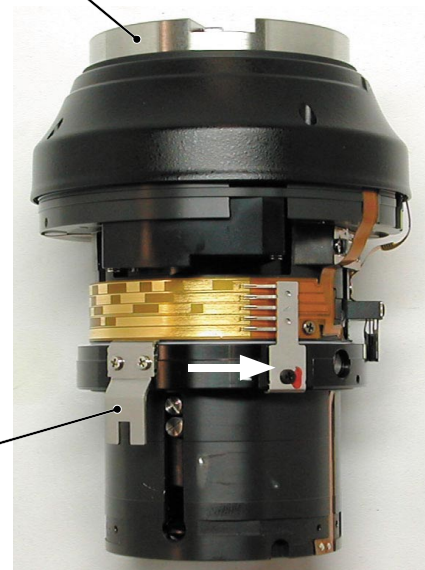

- ④ Rotate the focus coupling key to the infinity.
- ⑤ Mount the tool (J18004-1). Check the aperture diameter by looking through at the aperture from the opposite side from the bayonet.

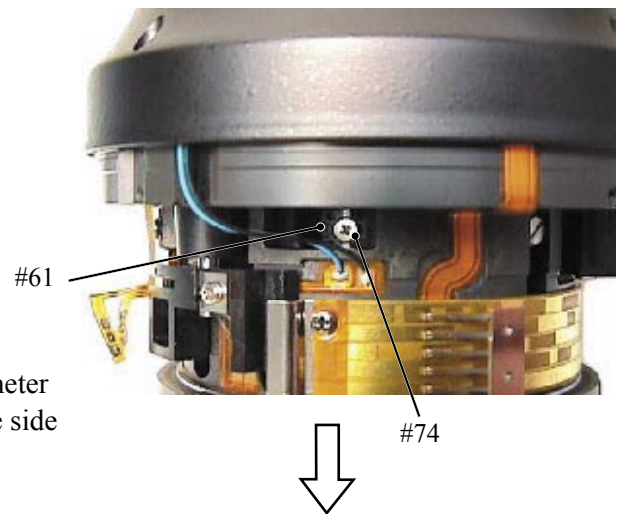

Standard (infinity-side): Full open

- ⑥ In case the result is out of standard, loosen the two adjustable screws (#100) of the aperture lever, and adjust by moving the [#23].
- ⑦ After the adjustment, fix the two screws (#100) with the screwlock.
- ⑧ If the adjustment is made for the infinity-side, go back to ①, and check the close-side again.

J18004-1

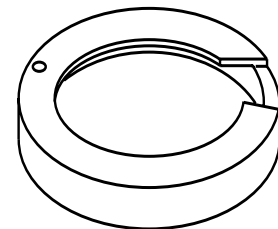

Adhesive: Screwlock

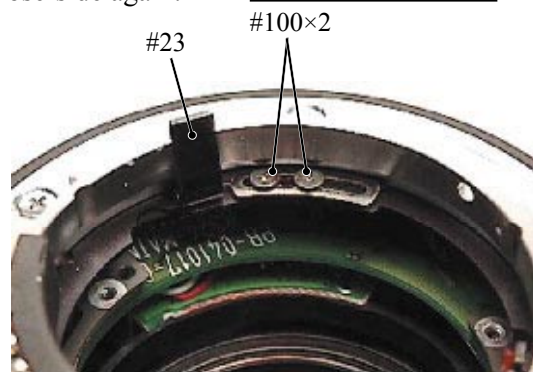

Temporary attachment of Contact unit

- ① Attach the contact unit with the two screws (#66) (temporarily).

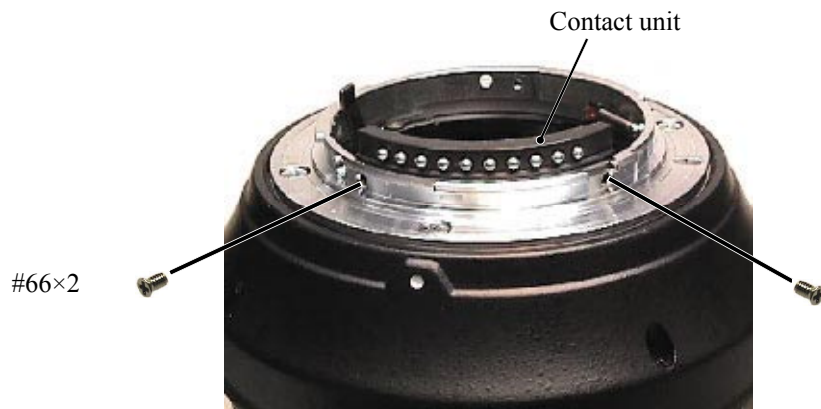

Focus index unit

- ① Position the focus index unit in the direction of the arrows "A", and attach the GMR unit with the three screws (#83) temporarily. ★ New tool

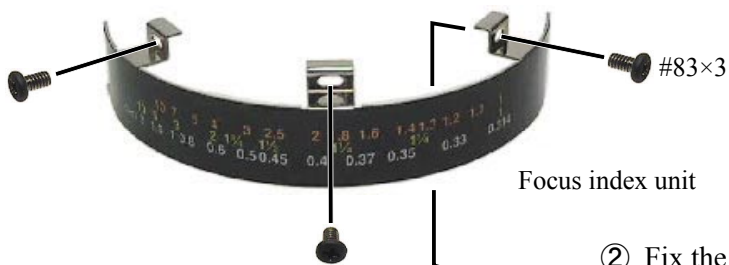

- ② Fix the infinity index tool (★ J11329) with the screw (#118).



③ Rotate the focus brush with the focus coupling key so that the focus brush is positioned at infinity.

④ Insert the infinity-positioning pin (★ J11319) into the "A" hole.

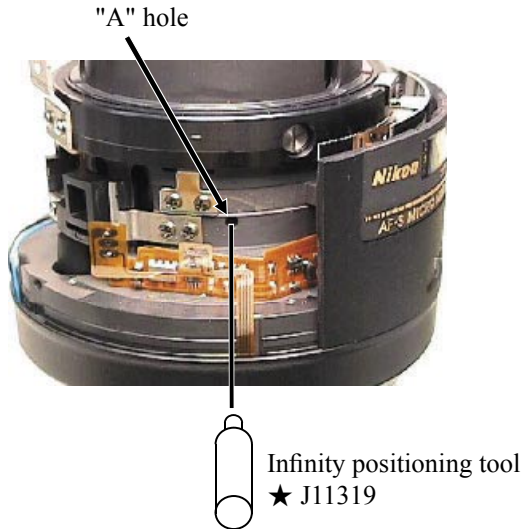

⑤ Loosen the three screws (#83). Move the focus index unit so that the index is positioned at the center of the focus-index "∞" mark.

⑥ Loosen the three screws (#83). Remove the infinity index tool (★ J11329) and the infinity positioning pin (★ J11319).



External tube unit



Name plate

- ① Attach the focus window (#94).
 (The focus window already has the adhesive double-coated tape adhered.)



#94

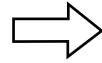

- ② Attach the name plate (#95).
 (The name plate already has the adhesive double-coated tape adhered.)



#95

Change-SW unit

- ① Make soldering bridges to joint the change-SW unit and the SW-FPC.
 ② Turn the VR SW of the change-SW unit to OFF, and assemble the change-SW unit into the lens, and fix it with the screw (#132).

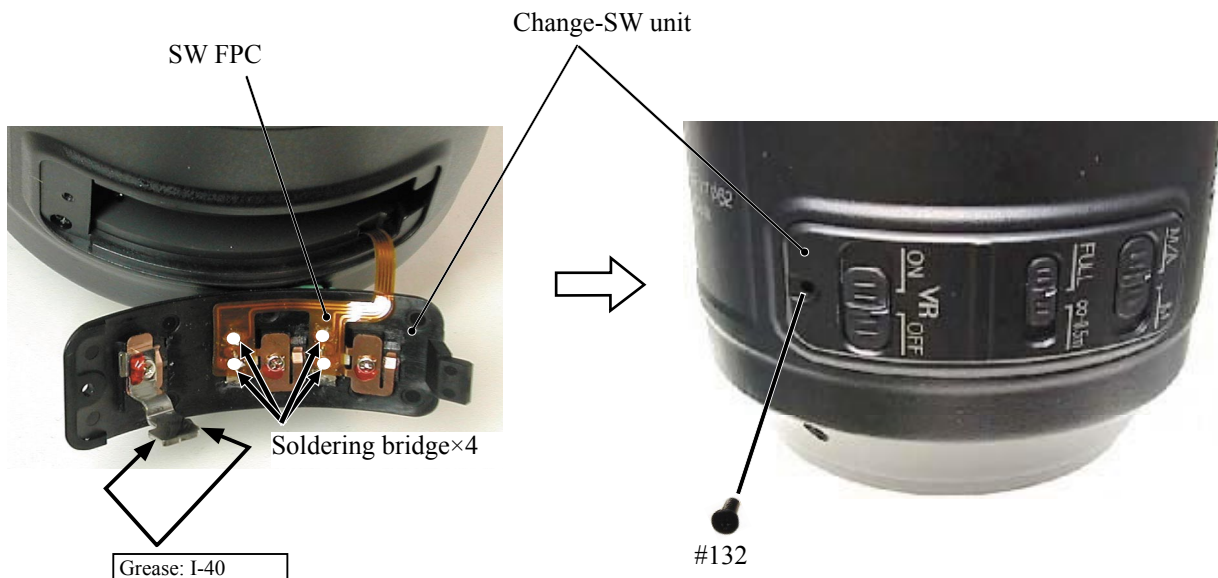

SWM unit

① Assemble the washer (#167) and the waver washer (#166).

Caution: The washer (#167) and the wave washer (#166) are put with their chamfered sides downwards.

Apply to arched-top 12 parts on both sides.

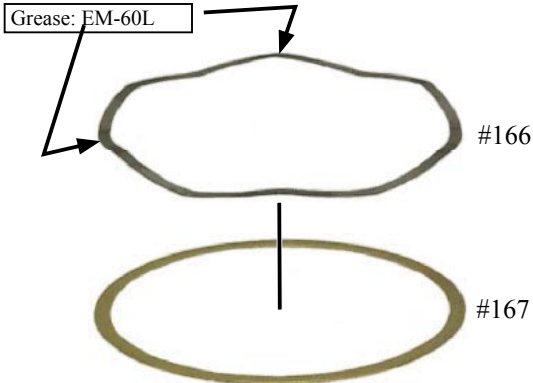

② Fit the pin of the SWM unit in the cutout of the focus coupling key (#87), and assemble them.

Caution: When assembling, do NOT touch the upper surface of the pattern.

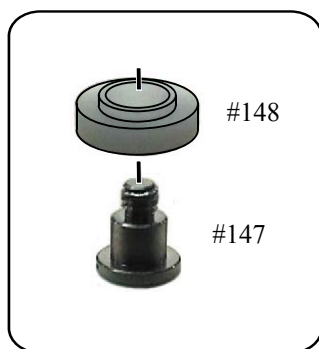

③ Fix the three rollers (#148) with the three screws (#147).

④ Attach four pieces of the tape (#211).



Adhesive: Lockend B

Power source brush unit

① Fix the power source brush unit 1 (with longer black wire) with the two screws (#163).

② Fix the power source brush unit 2 (with shorter black wire) with the two screws (#163).

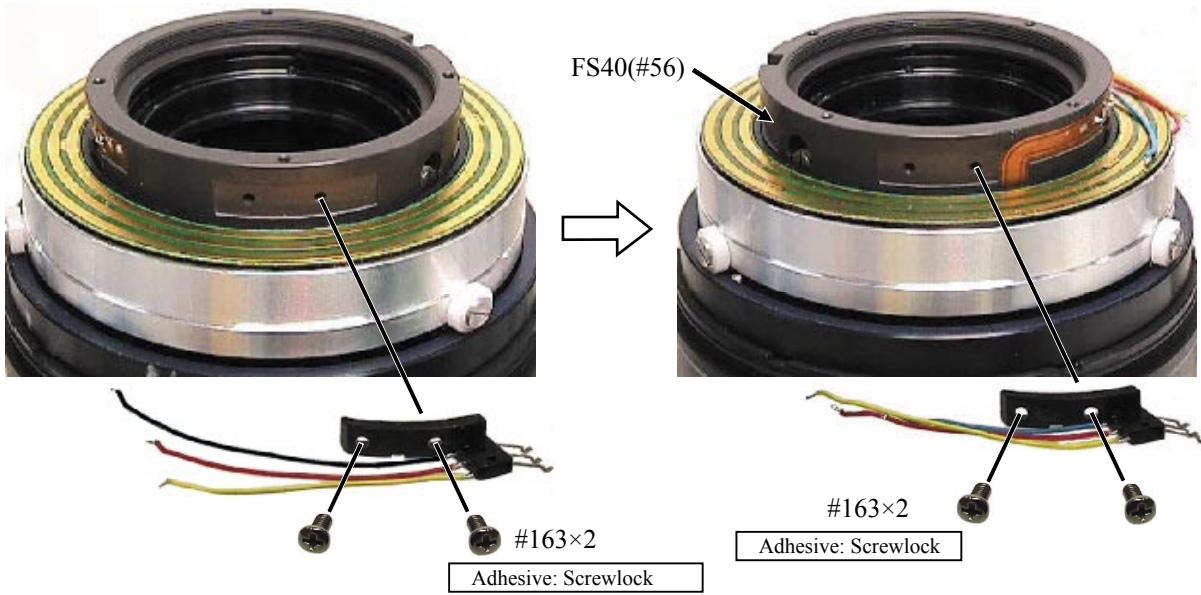

③ Attach the adhesive double-coated tape (#172) on the power source brush unit 1.

④ Attach the wires (yellow, red, and black) on the adhesive double-coated tape (#172).

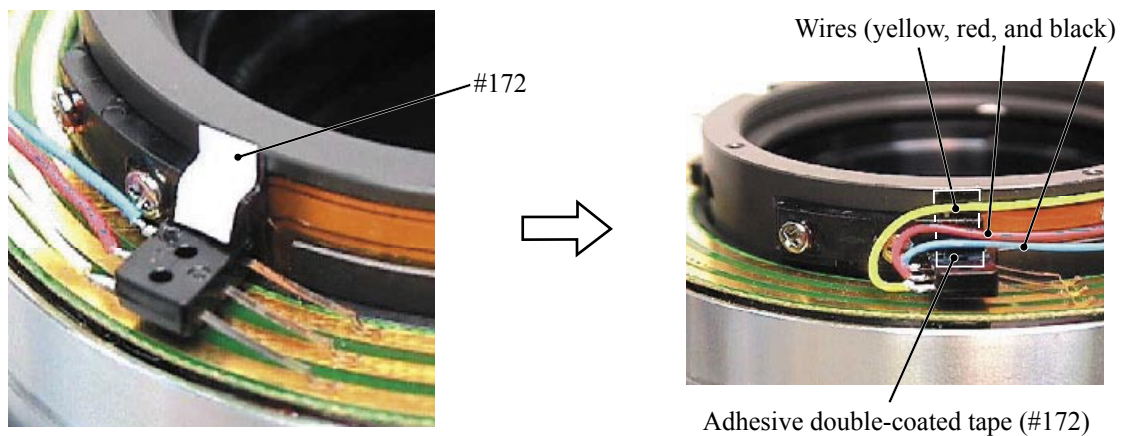

⑤ Solder each wire.

⑥ Arrange each wire.

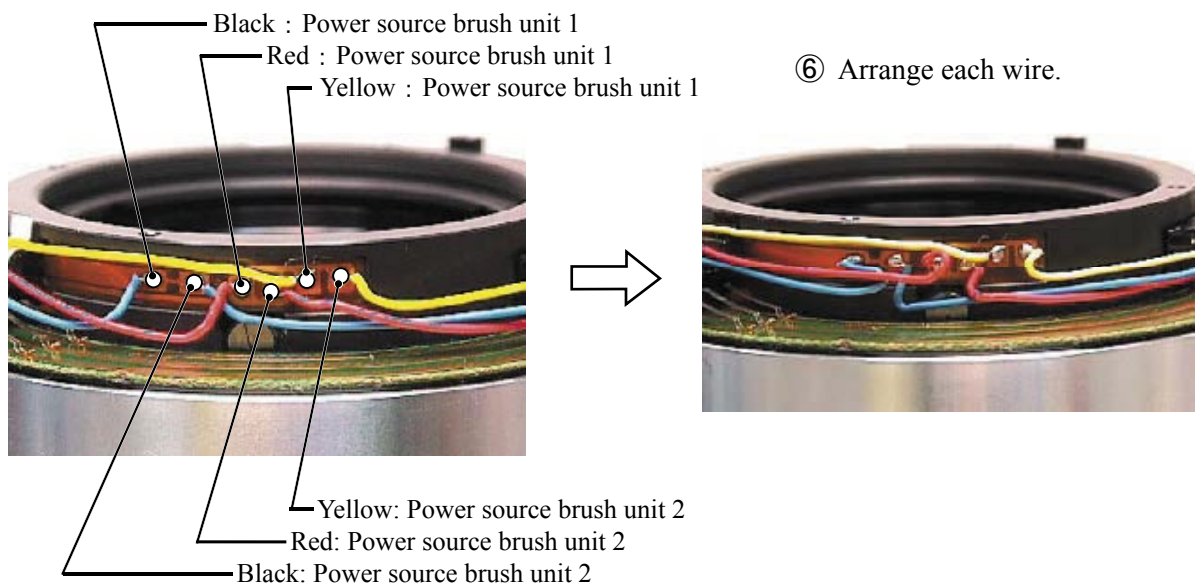

MF brush unit

① Fix the MF brush unit with the two screws (#163).

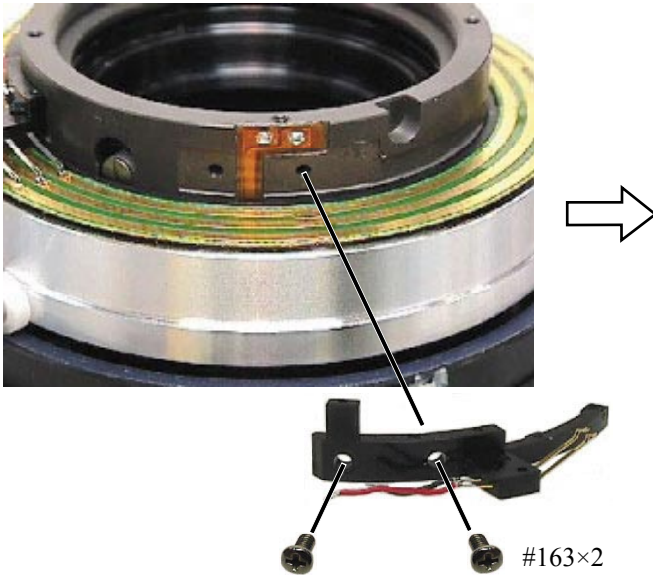

② Solder the red and black wires.

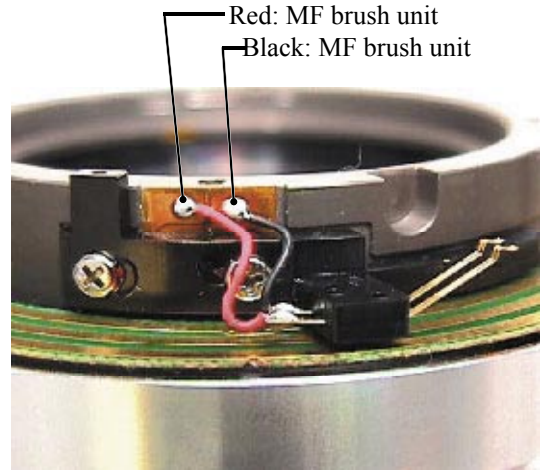

Focus ring (1) unit

Focus ring (1) unit



Concave surfaces meet with each other.

#139×2

Apply to sliding surface with #27

Grease: GE-8

3.2mm

※ In case the result is out of standard, correct the bending.

Apply to sliding surface with #27

Grease: GE-8

#139×2

Concave surfaces meet with each other.

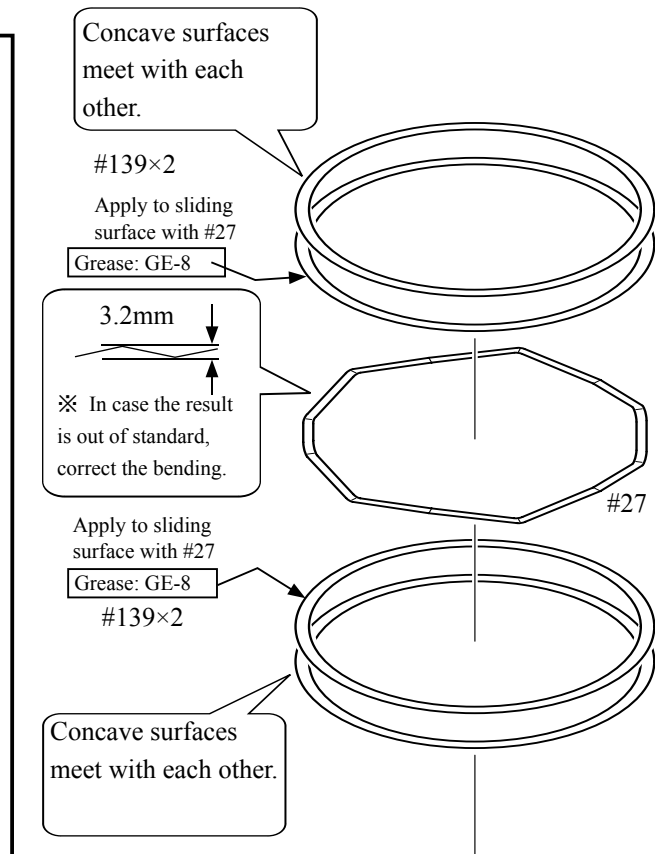

Focus ring (2) unit

① Assemble the focus ring (2) into the lens body.



② Put the washer (#175) by aligning the cutouts of the washer and the lens body.

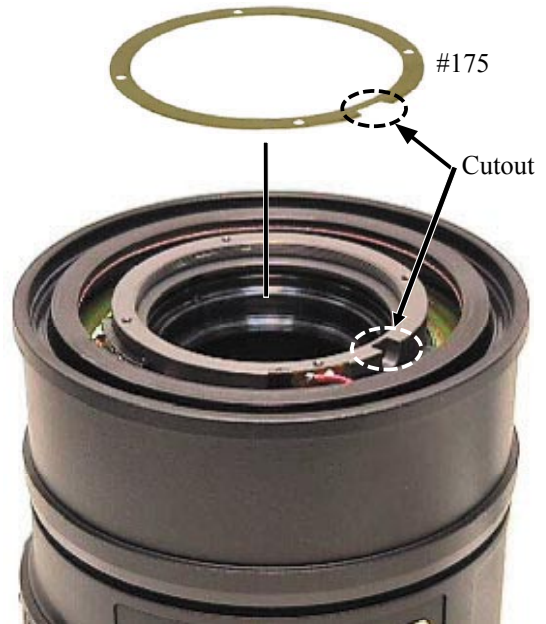

Filter ring unit

● Mount the filter ring unit on the lens body by aligning their indexes, then fix them with the four screws (#69).



Rubber ring



2nd lens group, 1-2nd lens group, 1-1st lens group

★ : New tool

1-1st lens-G assembling tool
(★ J11322)

Removing the 1-1st lens group needs the lens alignment work after the assembly.

Therefore, at service facilities where the lens alignment cannot be performed, do NOT remove the 1-1st lens group.

- ① Mount the 2nd lens group.
- ② Put the washer(s) (#137 selected from A-J), and set the 1-2nd lens group with the 1-2nd lens-G assembling tool (★ J11320).
- ③ Put the washer(s) (#152 selected from A-J). Fit the two pins of the 1-1st lens-G assembling tool (★ J11322) into the two holes of the 1-1st lens group, and assemble them into the lens body.
- ④ Fix the 1-1st lens group with the four washers (#151) and the four screws (#142).
- ⑤ Remove the 1-1st lens-G assembling tool (★ J11322).

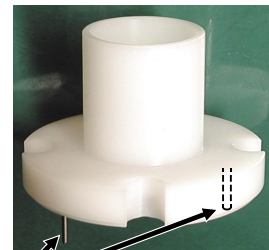

Pin ×2

Hole×2

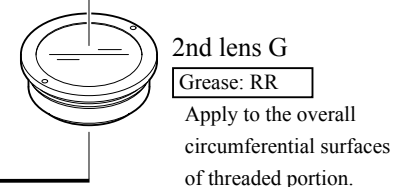
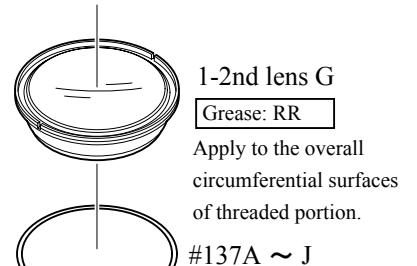
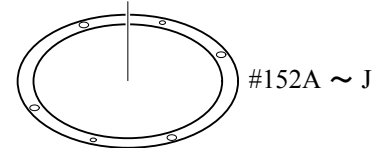
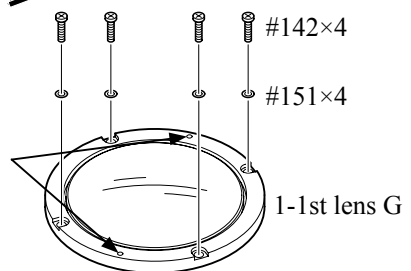

3rd lens group



3rd lens group

Grease: RR

Apply to the overall circumferential surfaces of threaded portion.

3rd lens-G assembling tool (★ J11323)

Removal of Bayonet mount

- Remove the bayonet mount temporarily, in order to assemble the VR lens group unit and the 5th lens group.

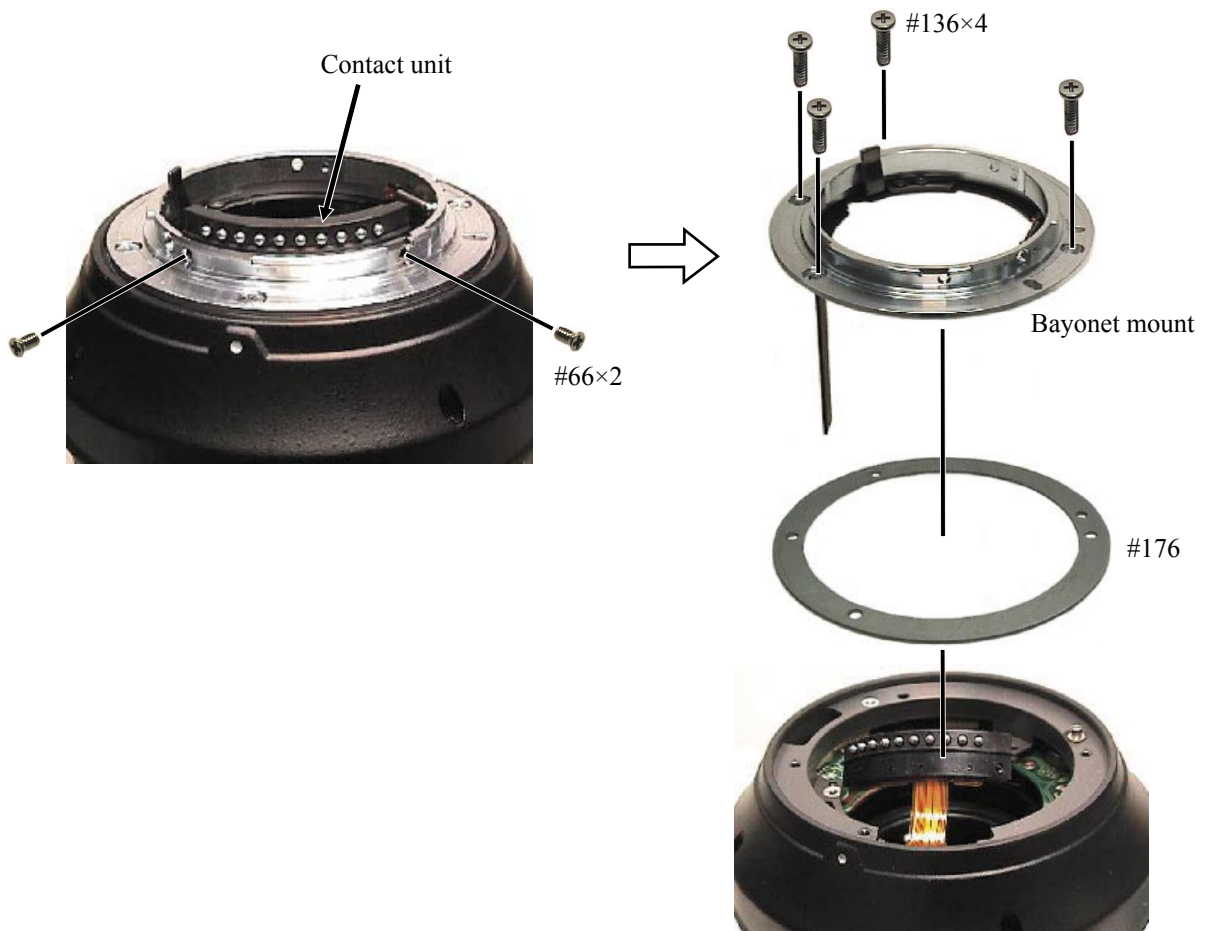

VR lens group unit

- ① Turn the VR SW to OFF.
- ② Align the concave portion of the VR fixing tool (★ J11321) with the FPC of the contact unit, and in addition, align the two pins of the tool with the two holes of the lens, then the mount VR fixing tool.



- ③ With the VR lens-G assembling tool (★ J11324), put the washer(s) (#138 selected from A-J) and mount the VR lens group unit.
- ④ Remove the VR lens-G assembling tool (★ J11324) and VR fixing tool (★ J11321) from the lens.

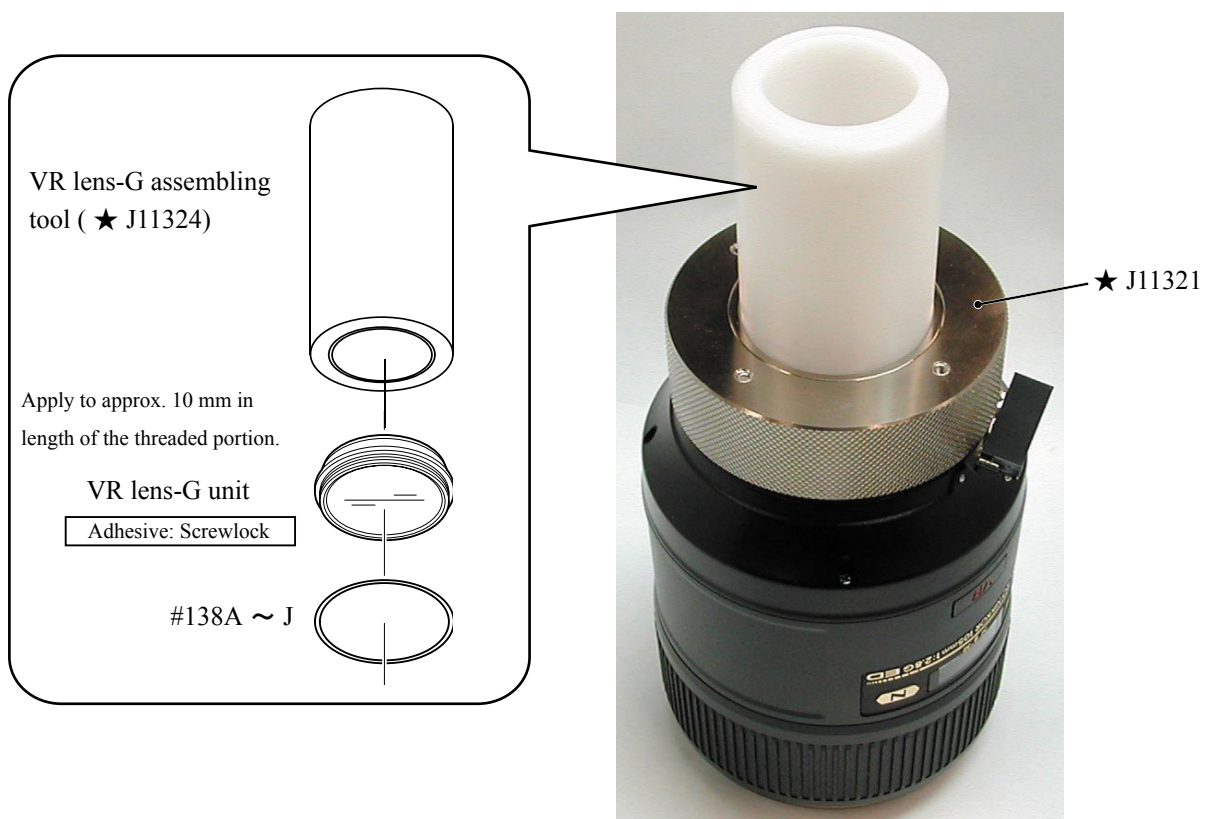

5th lens group

Caution:

Removing the 5th lens group needs the lens alignment work after the assembly.

Therefore, at service facilities where the lens alignment cannot be performed, do NOT remove the 5th lens group.

- ① Align the three pins of the 5th lens-G assembling tool (★ J11325) with the three holes of the 5th lens-G unit, and mount the tool on the lens body.
- ② Align the three holes of the lens body with the three pins of the tool, and assemble them. Then fix them with the three washers (#151) and the three screws (#113).
- ③ Remove the tool from the lens body.

Caution:

Tighten the three screws (#113) in the order from ① to ③.

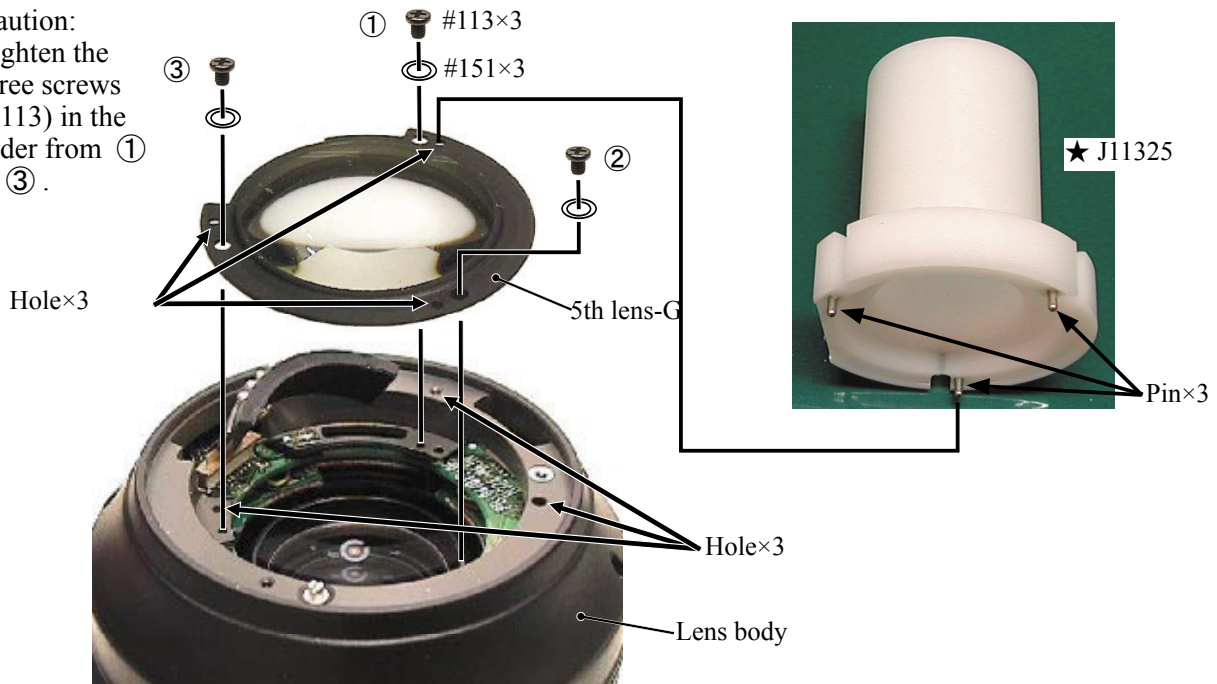

Bayonet mount

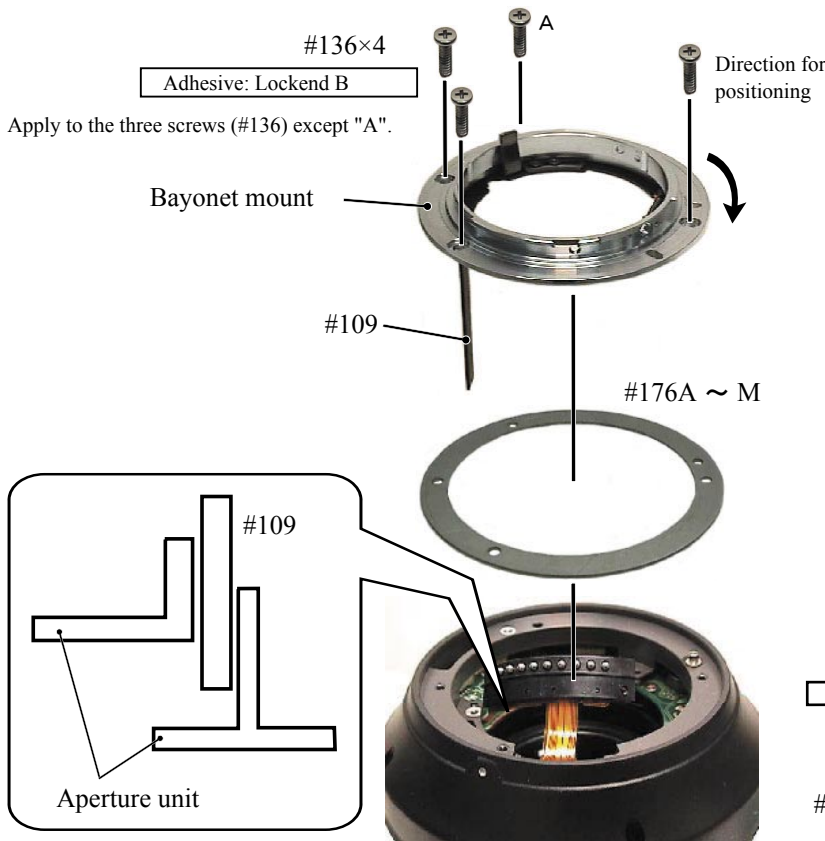

- ① Fit position of the holes of the washer (#176), and mount it.

- ② Insert the aperture lever (#109) of the bayonet mount into the aperture unit by fitting in the bending part of the aperture unit.

- ③ Fix the bayonet mount with four screws (#136).

- ④ Fix the contact unit with the two screws (#66).

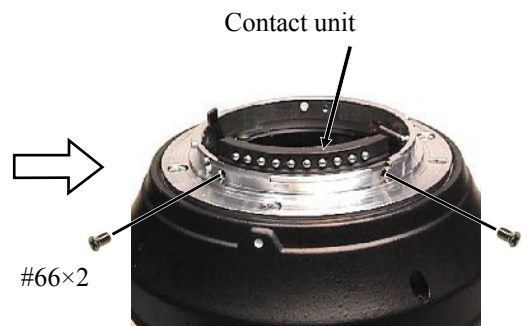

Preparation for inspection & adjustment of main PCB

- In case of replacing the main PCB, SWM unit or MR encoder unit, be sure to make the necessary adjustments as follows:

1. Adjustments

- Adjust the MR duty
- Adjust the driving frequency and motor control (including Focus preset adjustment)

2. Equipment and tools to be required

- Single output rated voltage power supply: 1 unit (6.0V 3.0A)
 - Oscilloscope: 1 unit For adjusting the MR duty, the driving frequency and motor control
 - AF-I communication box (J15306-1): 1 unit
 - AF-I communication adapter (J15307): 1 unit
- When the main PCB is replaced, be sure to perform “3. READING AND REWRITING OF EEPROM DATA” then “3. WRITING OF THE FIXED VALUES”.

AF-S VR 105 inspection and adjustment program (J18402)

The below hardware requirements are necessary for installing the program on a computer.

Ensure them before installation.

PC	IBM PC/AT compatible
OS	Windows XP Home Edition, Windows XP Professional, Windows 2000, Windows Millennium Edition (Me), Windows 98 Second Edition (SE), Windows 98,
CPU	Pentium II 266MHz ~ Pentium IV 2GHz
RAM (Memory)	32MB or more
HD	6 MB-or-more free space is necessary when installation
Monitor resolution	800×600 or more pixels
Interface	Serial interface ※ USB interface cannot be used.

As long as the above requirements are met, either desktop or notebook PC is available.

【System configuration】

★ : NEWTOOL

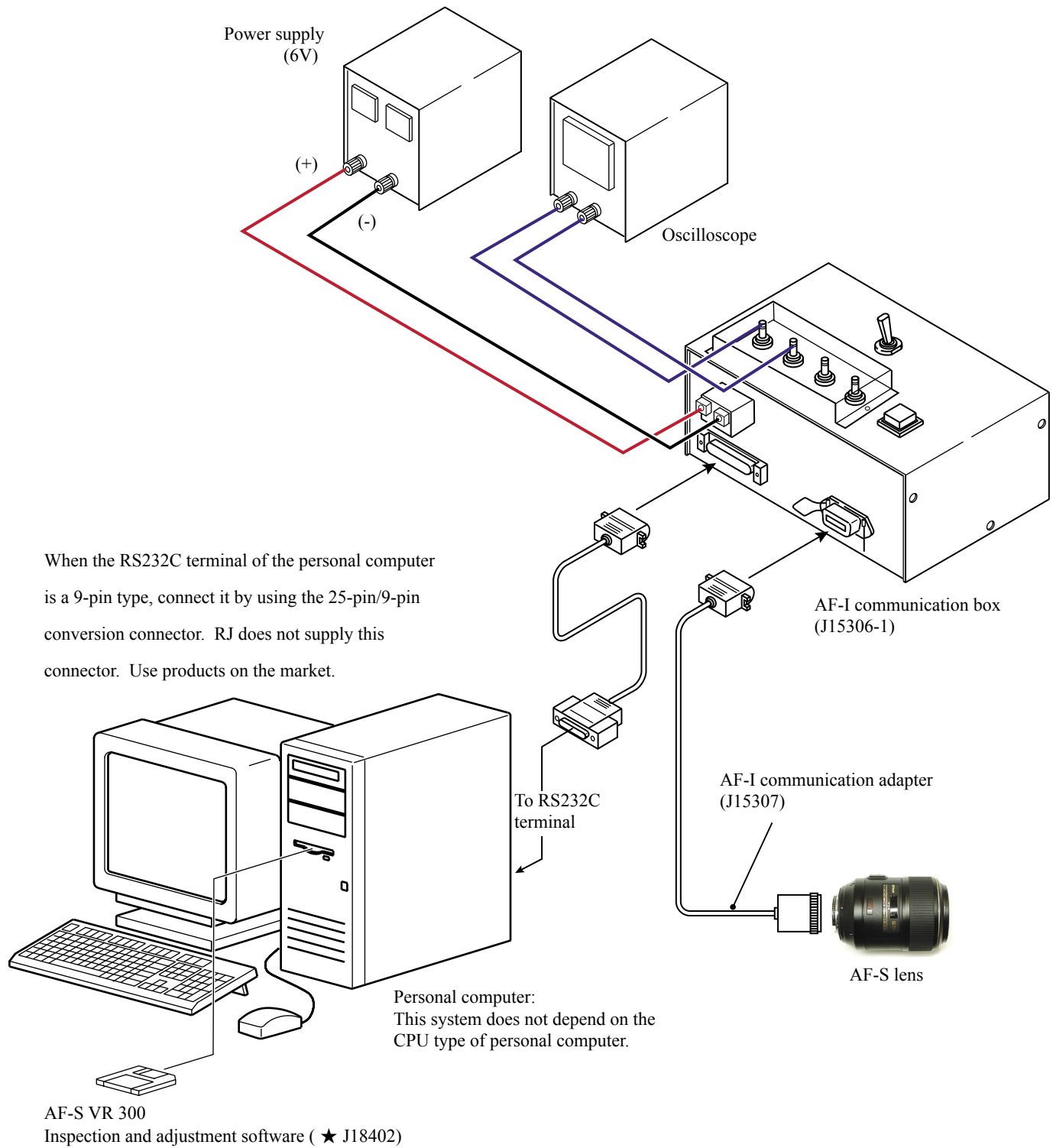

Adjustment of MR duty

- In case of replacing the main PCB, SWM unit and MR encoder unit, be sure to make adjustments.
- In case of replacing the main PCB, be sure to perform [3.READING AND REWRITING OF EEPROM DATA.] then [3.WRITING THE FIXED VALUES.]

How to adjust

- ① Make sure that the electric current and voltage of the connected rated voltage power supply are set to the set values, which are instructed on the PC screen. Then, turn the rated voltage power supply ON.
- ② Select "1. MR DUTY ADJUSTMENT" in the menu of the AF-S VR105 inspection program.
- ③ The confirmation screen for writing the fixed values in EEPROM appears. Select the appropriate item.
- ④ Following the instruction on the screen, rotate the MF ring slowly by hand in the direction from the infinity to the close distance position. Make sure that the waveform on the oscilloscope has duty 50% and stop the MF ring at the close distance-end.

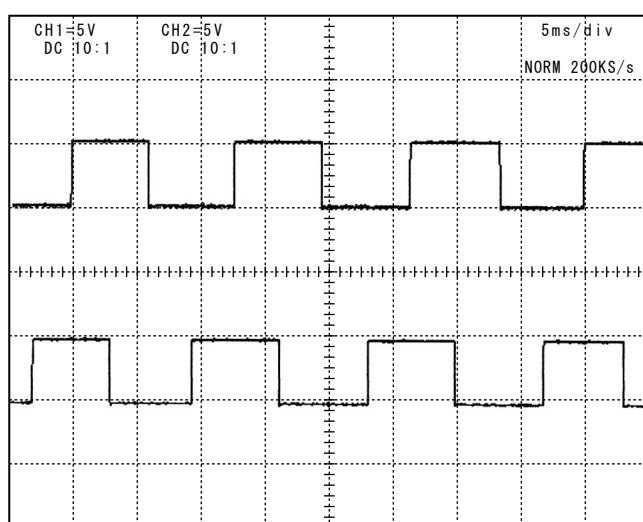

● Setting of oscilloscope

V/Div (CH1)	: 5V
V/Div (CH2)	: 5V
Coupling	: DC
Time/Div	: 5 m Sec
Trigger Mode	: NORMAL
Trigger Coupling	: DC
Trigger Source	: CH 1
Trigger Position	: -4 div
Trigger Type	: EDGE
Trigger Level	: 2.5 V

- ⑤ Following the instruction on the screen, rotate the MF ring slowly by hand in the direction from the close distance to the infinity position. Make sure that the waveform on the oscilloscope has duty 50% and stop the MF ring at the infinity-end.

Note : In case the waveform from infinity to close distance position or vice versa does not have duty 50%, repeat "INSPECTION AND ADJUSTMENT OF THE MR ENCODER OUTPUT WAVEFORM" on Page A9.

Standard H : L = 100 : 150 ~ 150 : 100 (50% ±10.0%)

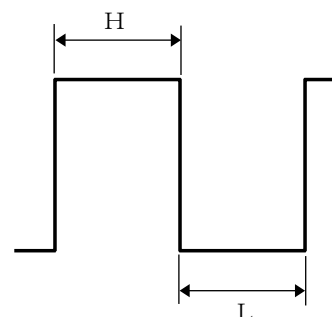

Adjustment of Driving frequency and Motor control

- In case of replacing the main PCB, SWM unit and MR encoder unit, be sure to make adjustments.
 - ① The method of connection of the rated voltage power supply and measuring tools is the same as "ADJUSTMENT OF MR DUTY".
 - ② Make sure that the electric current and voltage of the rated voltage power supply are set to the set values on the PC screen.
 - ③ Turn the rated voltage power supply ON.
 - ④ Select "2. ADJUSTMENT FOR DRIVING FREQUENCY & MOTOR CONTROL" in the menu of the AF-S VR105 inspection program. The lens automatically starts the driving of scanning.



Fig.1



Fig.2

- ⑤ When "Fig. 1" screen is displayed, and if "OK" is clicked, "drive frequency and the motor control adjustment" is completed. If "Adjustment could not be executed." of "Fig. 2" is displayed, make readjustment.

Even after the readjustment, if "Fig. 2" screen is still displayed, adjust the "MR duty" again and perform "drive frequency and the motor control adjustment" again.

However, after all the above, if the adjustment is still impossible, the SWM unit, the fixed tube unit, GMR tape unit, or MR head unit may be defective.

Inspection of Lens operations

Check the lens operations by using a personal computer after assembling.

- Check by personal computer
 - Check by the following considerations:
 1. MR encoder operations
 - Drive the scanning of lens and check the total number of pulses.
 - In case the MR head of the MR encoder and the magnetic tape are misaligned, the number of pulses becomes out of standard.
 2. Lens-servo stop accuracy
 - Check the number of overrun/underrun pulses (deviation of the stop position from the target position) per the specified lens driving.
 - In case the irregularity of mechanical operations does not take place in the focus ring driving unit, the underrun tends to occur if it is heavy in the cam ring rotation of the MR encoder, while the overrun tends to occur if it is light in its rotation of the MR encoder.
 3. Lens-servo time
 - Check the servo time (from starting and stopping the servo) when driving the specified lens by using the oscilloscope.
 - In case the irregularity of mechanical operations does not take place in the focus ring driving unit, the servo-time tends to be long if it is heavy in the cam ring rotation of the MR encoder, while the servo-time tends to be short if it is light in its rotation of the MR encoder.
 4. Switches and lenses
 - Check the ON/OFF operations of switches and the operating condition of the distance encoder.
 - After inspections
 1. When the MR encoder operations are not up to the standard:

Readjust the MR duty. (ref. Page A33.)

In case the pulse is not up to the standard, adjust the output waveform of the MR encoder again. (ref. Page A9.)

In case the pulse meets the standard, replace the ~~cam ring unit~~ ^{△ (Misdescription)} fixed-tube unit or the mechanical parts that make the focus ring drive. _{△ (Addition)}
 2. When the lens-servo stop accuracy is not up to the standard:

Check the output waveform of the MR encoder. If it is normal, replace the fix-tube unit or the mechanical parts that make the focus ring drive.

_{△ (Addition)}
 3. When the lens-servo time is not up to the standard:

Readjust the driving frequency and motor control.

In case the lens-servo time is not up to the standard even after the readjustment, replace the fix-tube unit or the mechanical parts that make the focus ring drive.

_{△ (Addition)}
 4. When switches do not work properly:

Check the wiring state of the troubled switch or replace it.



- AF-S VR 105 inspection program

- (1) Menu screen

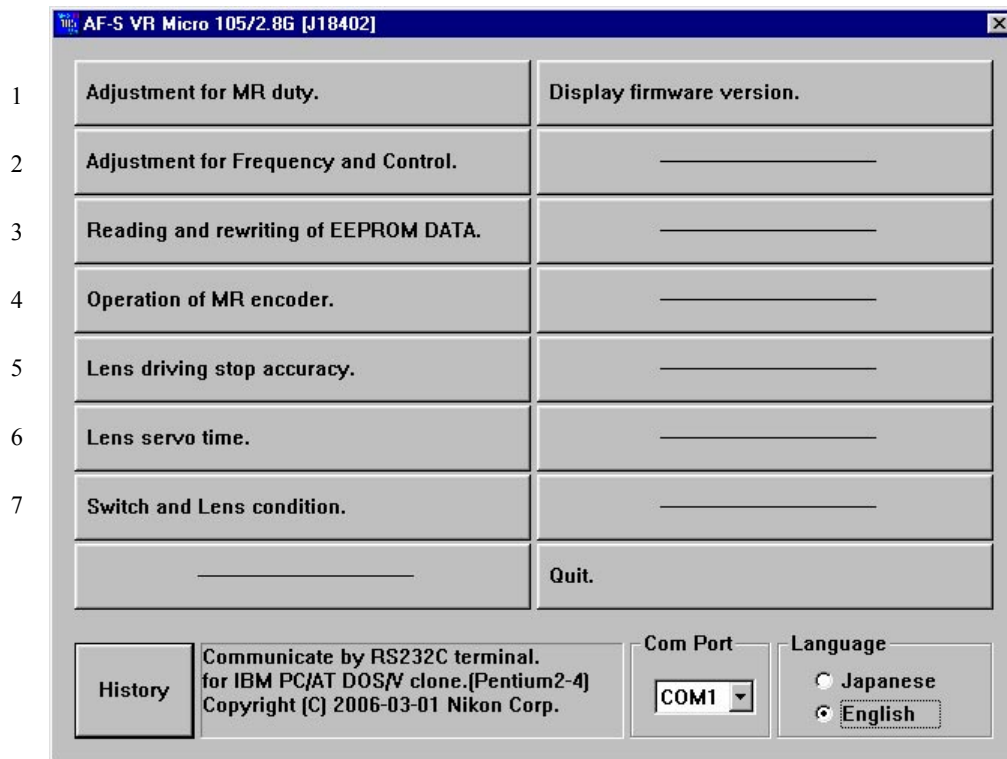

- Menu items

The items 1 and 2 are used for adjustments.

The item 3 is used for reading and writing EEPROM DATA.

"Store & Restore the EEPROM DATA" on the sub-menu 5 is the item by which all the data of EEPROM-values in the lens can be backed up or the backed-up files can be written in the lens.

(This is not used for regular repairs.)

The items 4~7 are used for inspections.

- Selection items

After selecting items screens appear, such as the lens selection, the focal length selection, the voltage setting, the inspection mode start.

The screens depend on the items. Follow the instructions of the personal computer.

- Initial driving

Drive scanning several times and stop at infinity-end.

(2) Inspection of MR encoder operations

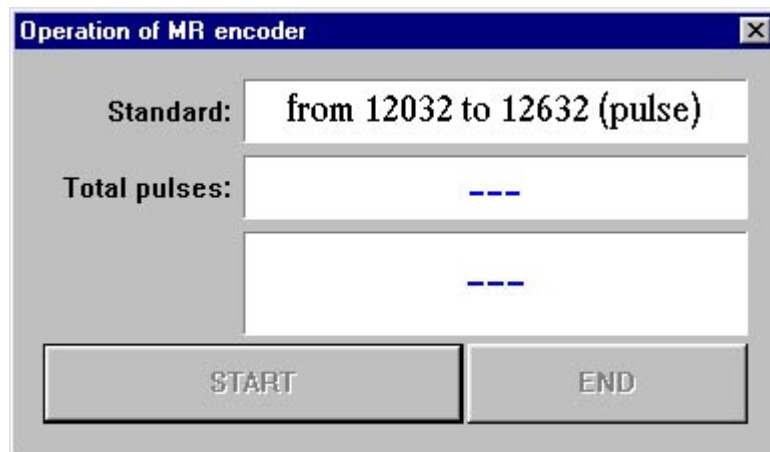

Caution : If the MF ring is rotated while the lens scanning is driven, the pulse shows an abnormal value.
Do NOT touch the MF ring during operations.
Make inspections at the 5 positions as below.

(Lens position in inspecting)

Lens inclination	Position of index window
Horizontal	Up, right and left
Front lens group 90° upward	
Front lens group 90° downward	

When the inspection ends, the result of the next page appears.

The difference in pulse before and after the inspection must be within the standard.

< Standard > Total pulses : 12332 ± 300 PLUSE(S)

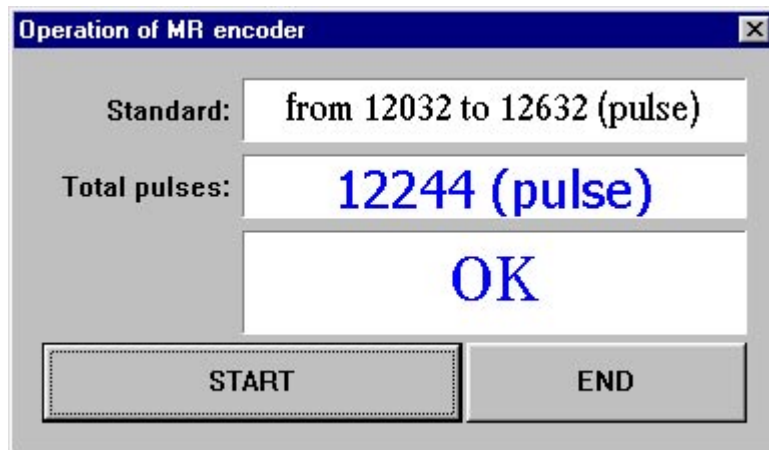

(3) Inspection of lens-servo stop accuracy

If the lens stops while inspecting the lens-servo stop accuracy, input a figure between 0-1000 for the delay time (msec: millisecond), which prevents stopping the lens, into the entry field of "DELAY-TIME" of the below Fig.3,

Note:

The value of "ADJUST DELAY-TIME" is set by the adjustment software. So, if the lens does not stop during the inspection of "LENS DRIVING STOP ACCURACY", any value can be input without problem.

However, the larger the value of "ADJUST DELAY-TIME" gets, the longer the inspection time becomes.

Lens driving stop accuracy

Delay Time(0-1000): [msec]

Round counter: Drive mode:

Servo counter: Over / Under run pulse:

[%]	DF1	DF2	DF3	DF4	DF5	DF6	STD
Ratio1:	<input type="text"/>	<input type="text"/>	<input type="text"/>	<input type="text"/>	<input type="text"/>	<input type="text"/>	< 40.0%
Ratio2:	<input type="text"/>	<input type="text"/>	<input type="text"/>	<input type="text"/>	<input type="text"/>	<input type="text"/>	< 10.0%

Max pulse(abs): < 13 pulus

START END

Fig.3

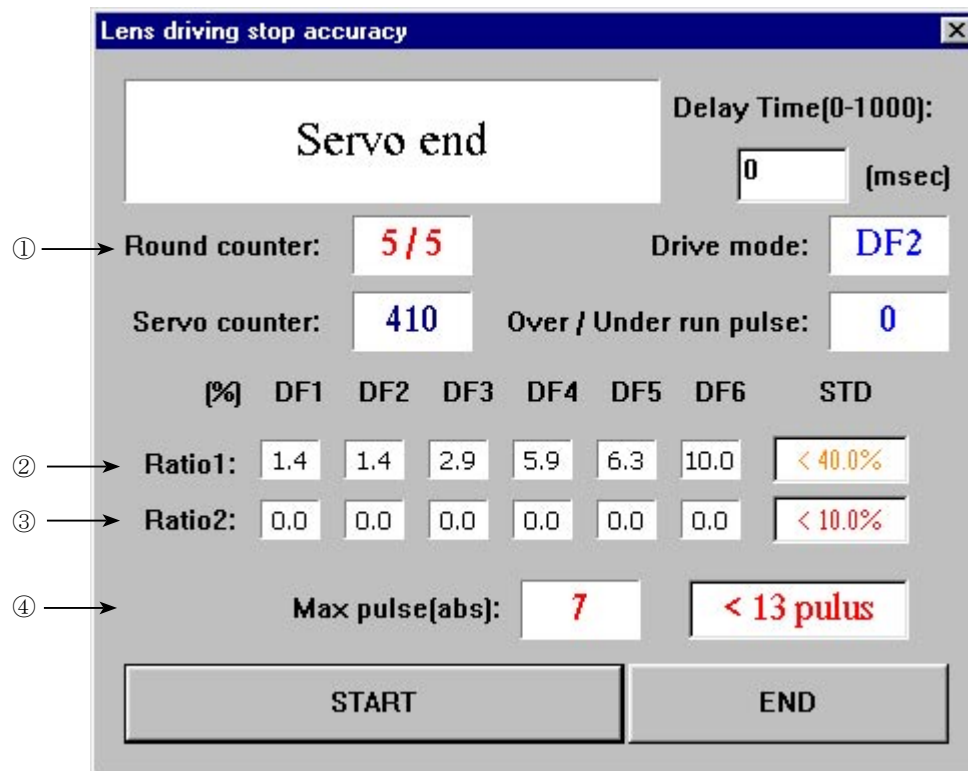

Caution : If the MF ring is rotated while the lens scanning is driven, the pulse shows an abnormal value. Do NOT touch the MF ring during operations.
During the lens driving, the above screen is displayed. Make inspections at the 5 positions as below.

(Lens position in inspecting)

Lens inclination	Position of index window
Horizontal	Up, right and left
Front lens group 90° upward	
Front lens group 90° downward	

The number of overrun/underrun pulses must be within the standards after the 5 lens back-and forth driving motions ("5/5TIME (S)." in [1] of the display).

Standard RATIO (1) is 40% or less for Df1~Df6. ② of the screen
(Occurrence ratio of 5~12 pulses)

RATIO (2) is 10% or less for Df1~Df6. ③ of the screen
(Occurrence ratio of 9~12 pulses)

Occurrence of 13 or more pulses is zero for Df1~Df6. ④ of the screen
(Only one occurrence indicates malfunction.)

※ "Df1~Df6" shows the lens driving amount.

(4) Inspection of lens-servo time

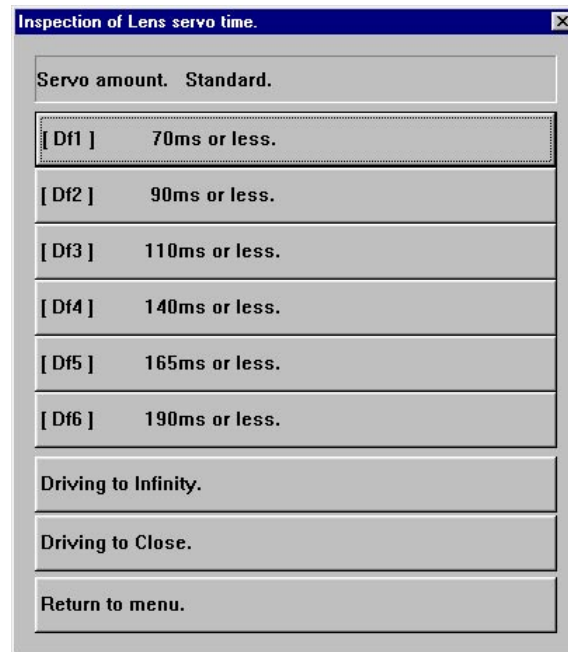

Select the servo driving amount respectively. Each lens-servo drive time must be within the standard.

Caution : If the MF ring is rotated during inspections, the waveform shows an abnormal value. Do NOT touch the MF ring during inspections. Make inspections at the 5 positions as below.

(Lens position in inspecting)

Lens inclination	Position of index window
Horizontal	Up, right and left
Front lens group 90° upward	
Front lens group 90° downward	

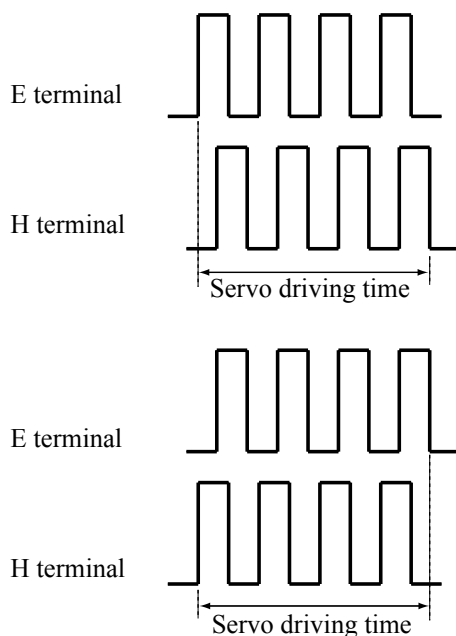

●Oscilloscope setting

- V/Div : 5V
- Coupling : DC
- Time/Div : 20 m Sec
- Trigger Mode : SGL (S)
- Trigger Coupling : DC
- Trigger Source : CH1
- Trigger Position : -4 div

※ The waveforms of E and H terminals have the forms for going up for start and going down for start.

(5) Inspection of switches and lens conditions

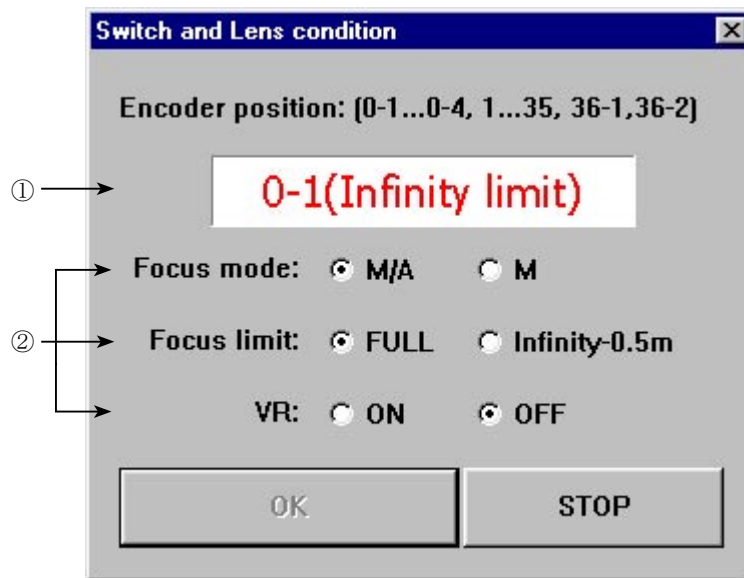

- ① The signals of the focusing encoder and zooming encoder.
The value changes by turning the MF ring with M or M/A of the lens driving mode selector.
- ② The status of Switches

Necessary adjustment when replacing parts

Adjustments Parts to be replaced	Adjustment for MR duty (Write fixed value, when replaced Main PCB); driving frequency; motor control	Inspection & adjustment for MR encoder operations; lens-servo stop accuracy; lens-servo time; switches; lens condition	VR adjustment
Main PCB unit	○	○	○
SWM unit	○	○	
VR unit		○	○
Jyro unit		○	○
GMR unit	○	○	
Fix-tube unit	○	○	

Lens Alignment

Note:

This adjustment is required when the front (1-1st) and/or the rear (5th) lens group(s) are/is removed.

(1) Preparation of Lens optical alignment equipment

※ For this AF-S VR MC105/2.8G, the lens alignment equipment (for center and periphery) cannot be used in terms of accuracy. Instead, the point tester and the following devices are used.

Chart-shooting device for Lens alignment

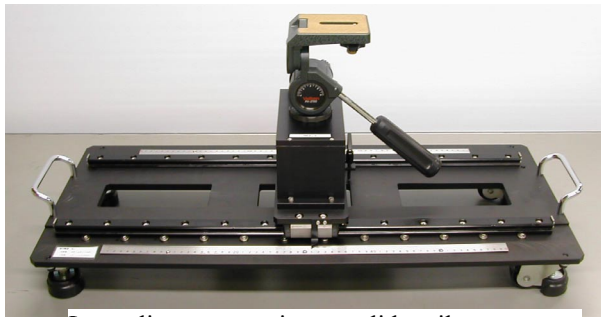

Lens alignment equipment slide rail (J19129)

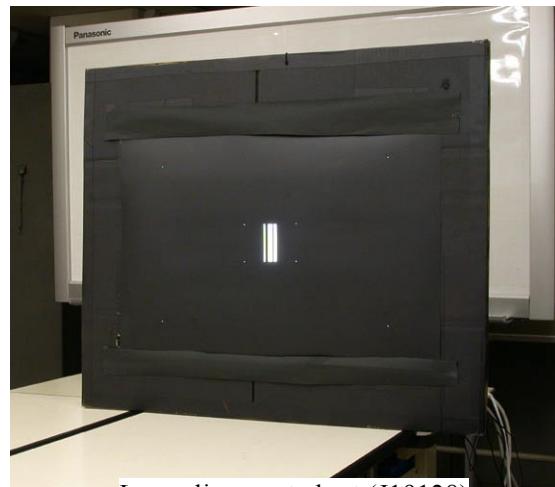

Lens alignment chart (J19128) embedded in cardboards

★ New tool

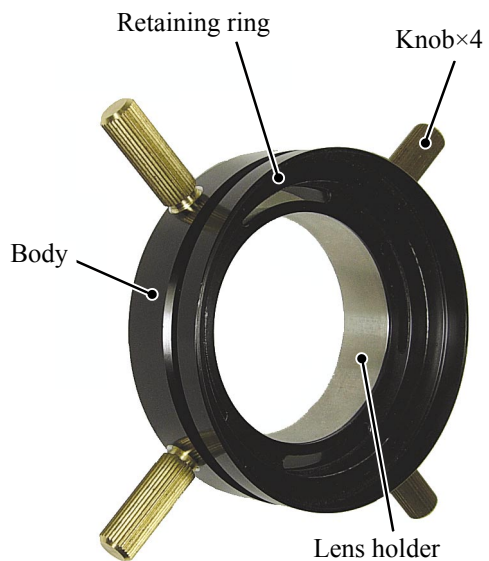

1-1st lens-G alignment tool (★ J11327)

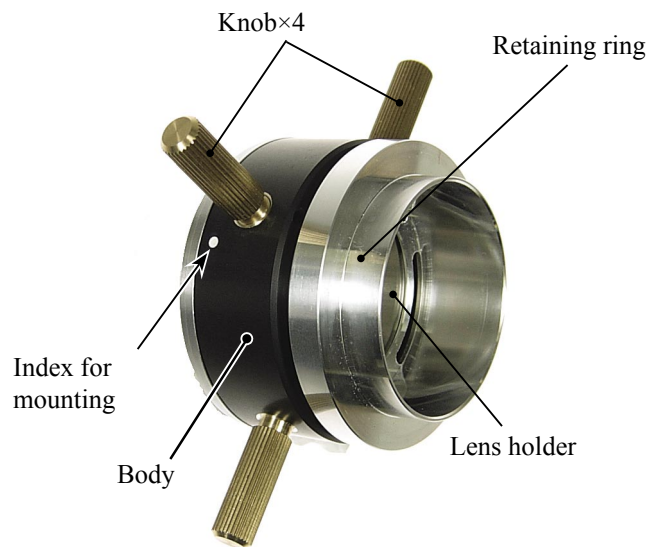

5th lens -G alignment tool (★ J11328)

★ New tool

(2) 5th lens-group alignment (for center)

- ① Mount the rear cover ring temporarily, and fix it so that the aperture becomes full open.
- ② Set the focus ring to " ∞ ", and mount it on the point tester.
- ③ Check the optical axis. If the result is "OK" as shown below "Fig.1", go to the next "『(3) Chart shooting for the 1-1st lens-G alignment (for periphery)』". If "NG", follow the below ④, and make alignment for the 5th lens group.

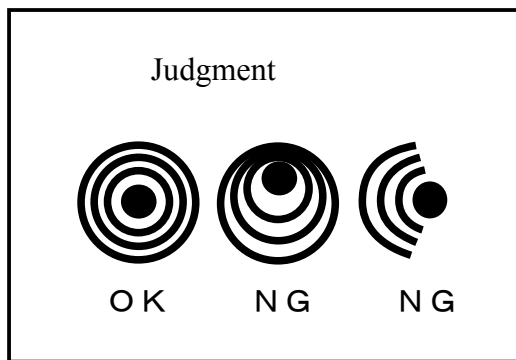
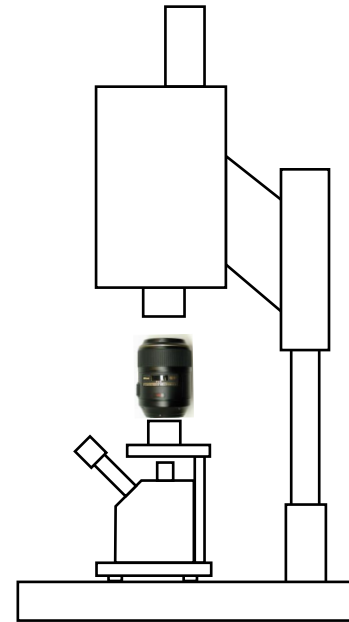

Fig. 1



Point tester

- ④ Give the four knobs of the 5th lens-G alignment tool (★ J11328) about half-turn counterclockwise from the position where the knobs are screwed completely.
- ⑤ Give the retaining ring of [★ J11328] about two-turns counterclockwise from the position where the retaining ring is screwed completely.

Caution: If turning the retaining ring counterclockwise is not enough, the rotation becomes heavy or impossible when the tool is mounted. In this case, turn it counterclockwise further.

- ⑥ Remove the rear cover ring from the lens, and mount [★ J11328] on the bayonet.



★ New tool

- ⑦ Rotate the retaining ring until the three setscrew (#113) of the 5th lens group can be seen.
 (The slightly loosened retaining ring is acceptable at the place where the above screw can be seen.)

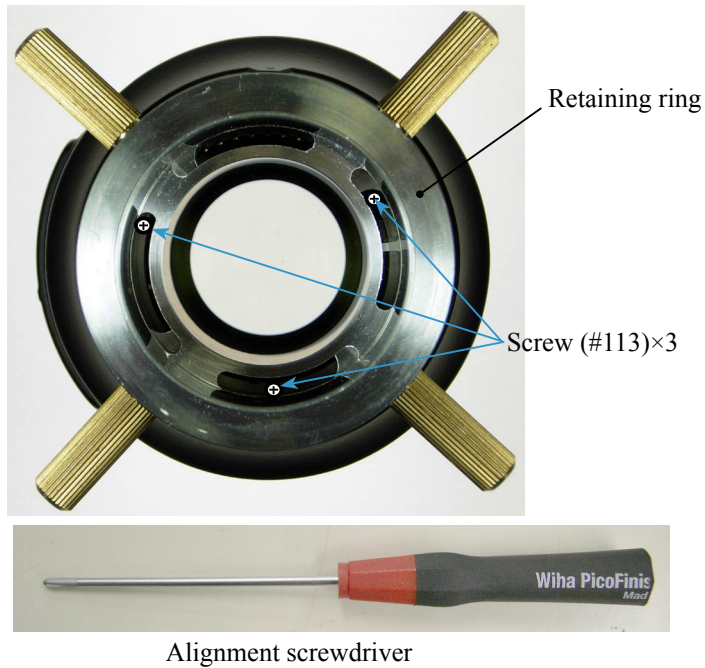

- ⑧ Loosen the three screws (#113) with the alignment screwdriver.
 ⑨ Remove the lens mounting of the point tester.
 ⑩ Insert the convex portion of the retaining ring of the 5th lens-G alignment tool (★ J11328) into the hole of the lens mounting of the point tester. Then set the lens. (Set the focus ring to "∞".)

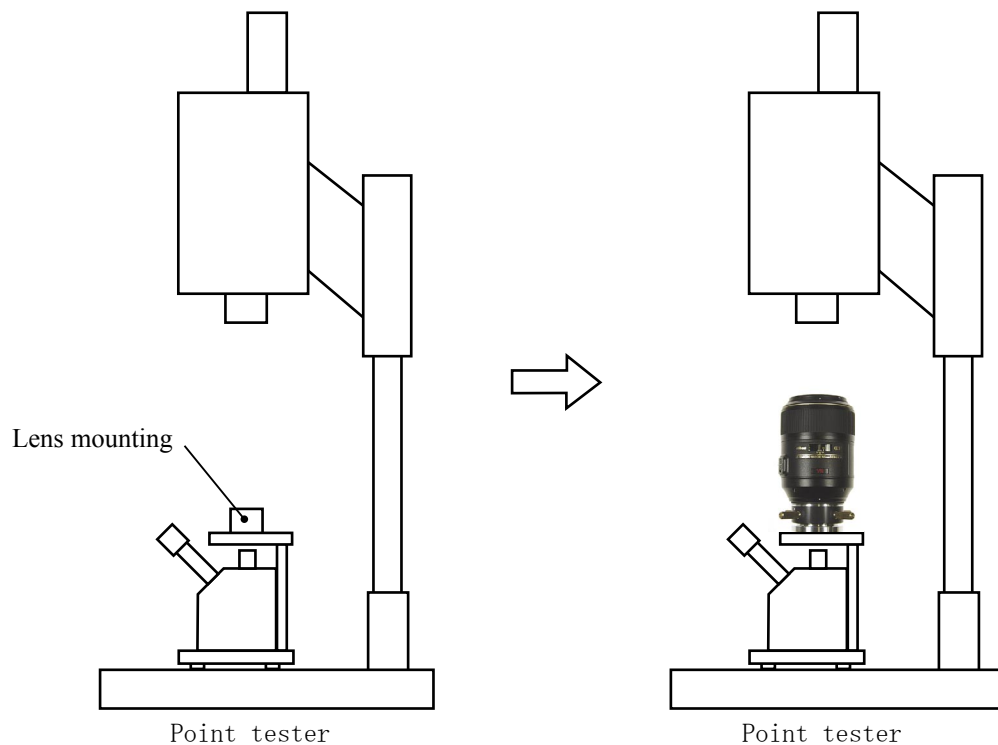

- ⑪ Check the optical axis by looking through the eyepiece lens of the point tester. Rotate the knob of the 5th lens-G alignment tool (★ J11328), which is set in the lens, and adjust until the optical axis becomes "OK" (ref. Fig. 1). (ref. ⑭ for how to rotate.)
- ⑫ When the adjustment is completed, tighten the three screws (#113) with the alignment screwdriver, and remove [★ J11328] from the lens.
- ⑬ Apply the screwlock to the heads of the three screws (#113).

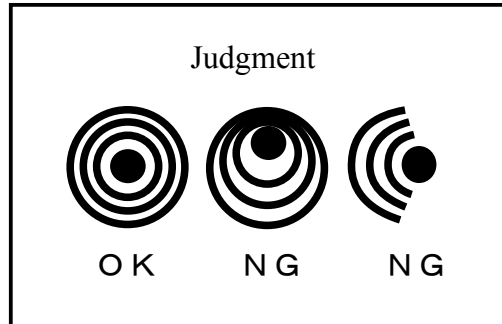

Fig. 1

- ⑭ To operate [★ J11328], hold the knobs at the same time which are diagonally positioned to each other. When the one knob is rotated and slid down towards a direction, the other knob must be rotated and slid up towards the opposite direction. Adjust the position of the lens. (ref. below A ~ D)

A. Lens moves diagonally towards upper-right direction



B. Lens moves diagonally towards lower-left direction

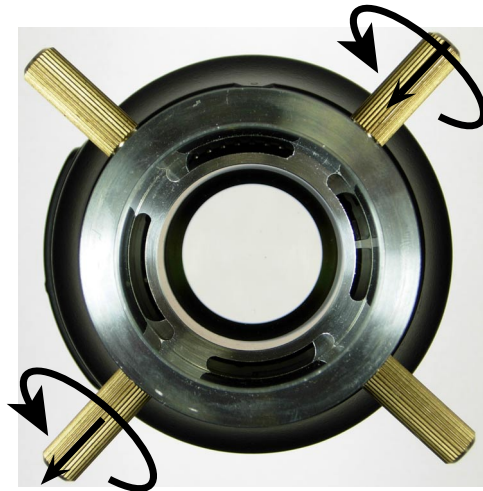

C. Lens moves diagonally towards upper-left direction



D. Lens moves diagonally towards lower-right direction

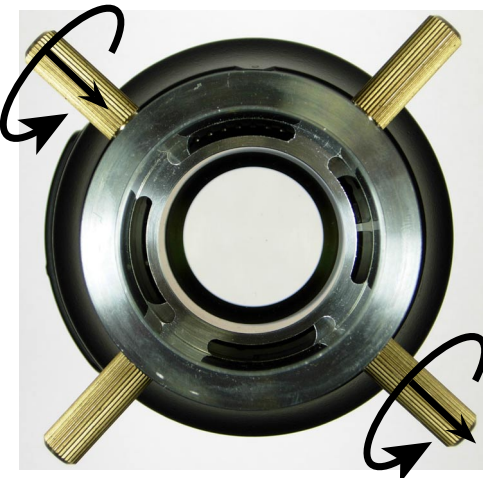

(3) Chart shooting for the 1-1st lens-G alignment (for periphery) Δ (Addition)

- ① Prepare a camera (D100). Set the shutter speed to "M1/80" with fullaperture and the focus mode to "S".
On the shooting menu, set "Image Quality" mode to "RAW", "WB" to "Preset" and "ISO" to "200".

Δ (Addition) Turn on the vibration reduction SW of lens.

- ② Set up the camera (D100) on a tripod on the slide rail. Set the indication pointer of the tripod to 30 cm.

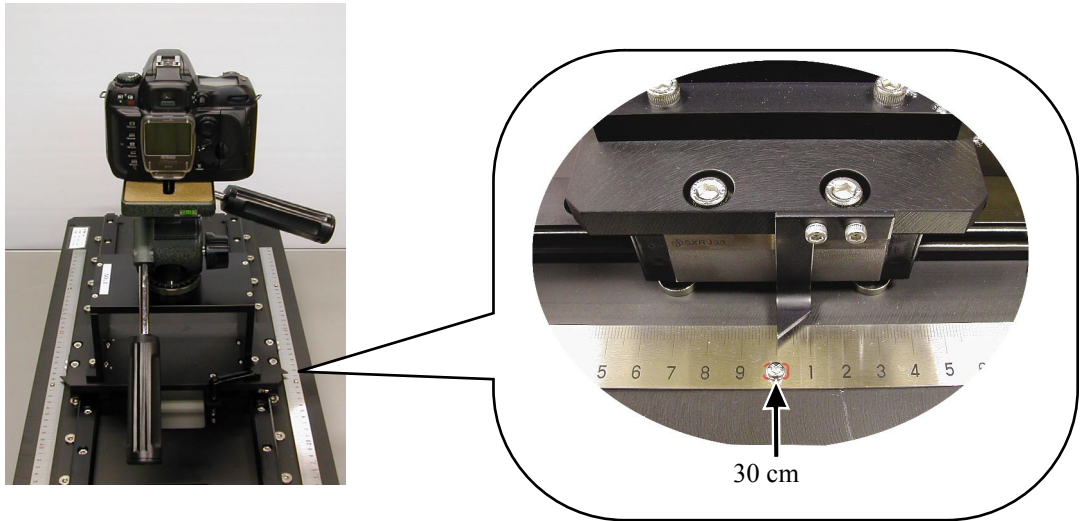

- ③ Set the alignment chart (J19128) as shown below.

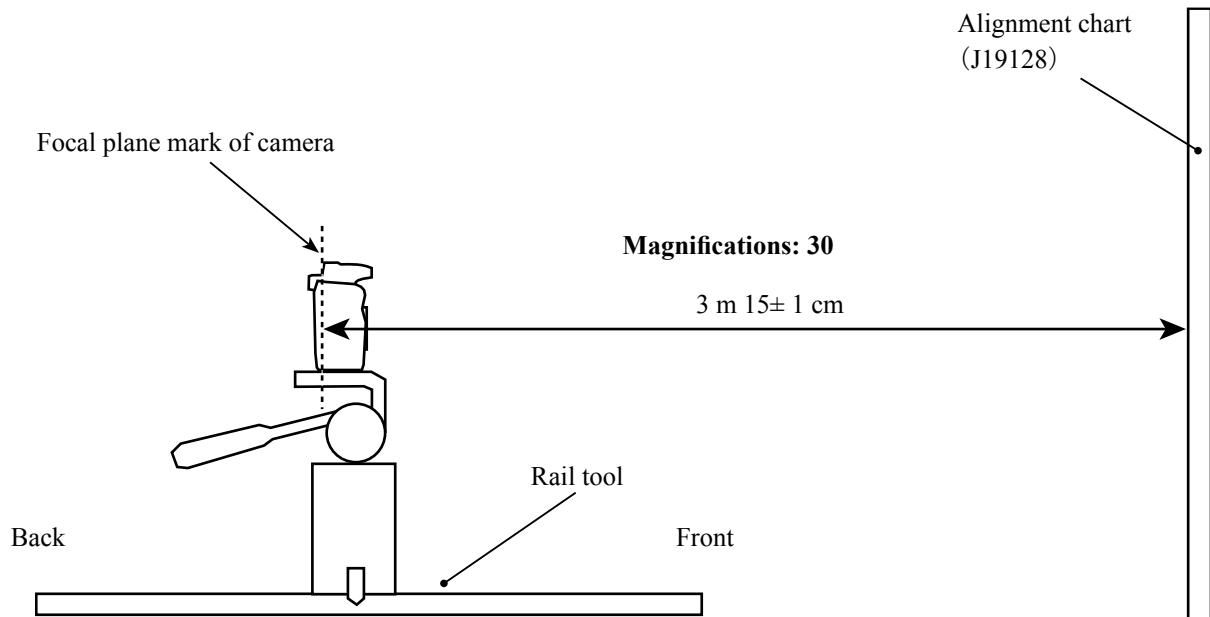

- ④ Turn the power of viewers (5 pcs.) to ON.

(Note: If the batteries of viewers are exhausted with decreased brightness, the shooting data cannot be obtained correctly.)



Front

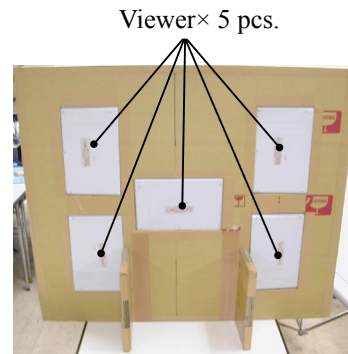

Back

- ⑤ Fit the lens to be examined in the camera (D100).
- ⑥ By looking through the viewfinder, adjust the height and tilt to make the chart fill the entire finder field frame.
- ⑦ Adjust the tilt of the slide rail to make the three chart lines position in the center of the viewfinder, when the tripod is slid all the way to the front and back.

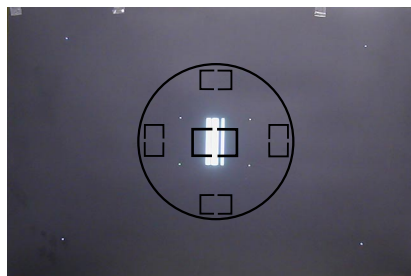

- ⑧ Connect the PC and camera via USB cable. Rotate and set the focus ring of the lens to "∞". (Camera setting: Mass Storage)
- ⑨ Start the adjustment software (LWM.exe).
- ⑩ "Lens Select" window opens. Select "AFS VR 105/2.8G", then click "OK" button.
- ⑪ Click the "Reset all log" button.

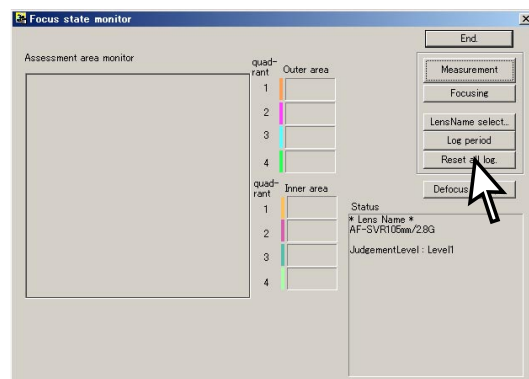
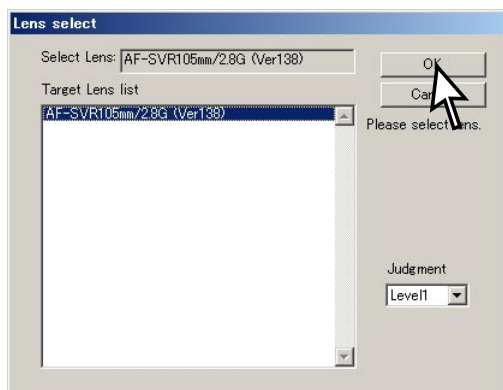

- ⑫ Set the indication pointer of the tripod to 30 cm.
- ⑬ Darken the room.
- ⑭ Click "Focusing" button. AF is activated to focus and the shutter is released.

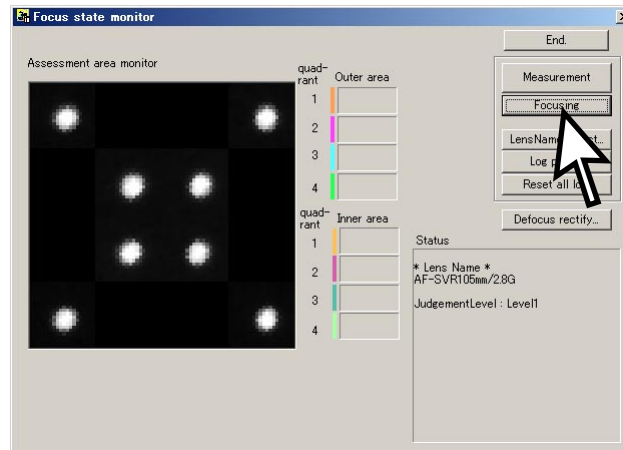

- ⑮ Set the focus mode of the camera (D100) to "M".
- ⑯ Slide the tripod to the front by 18 ± 0.1 cm.
- ⑰ Click the "measurement" button of the adjustment software.
- ⑱ When the shutter of the camera is released, slide the tripod to the back by 6 ± 0.1 cm and make a remeasurement.
- ⑲ Again, slide the tripod to the back by 6 ± 0.1 cm and make a remeasurement.
Repeat this operation four more times, totalling in seven measurements.
(The total sliding distance is 36 cm.)

Note 1: When the below warning is given, there may be some defects in the brightness of the viewers and/or parallelism of the chart and camera, etc. So correct the above and make a remeasurement.

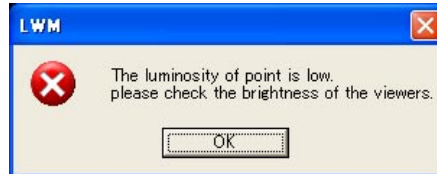

Note 2: When the below warning is given, recheck that the Quality mode of the camera is set to RAW.



- ⑳ After the seven measurements, point the cursor to the confirmation screen of the software. Click it three times, and if "END" is displayed on the Information, the lens optical alignment is completed. If "END" is NOT displayed (Adjust peripheral alignment by $\frac{J19125}{J11327} \Delta$ With below value), go to the next "(4) 1-1st lens-group alignment (for periphery)" to readjust.

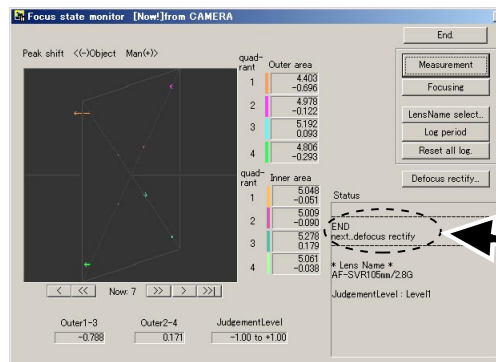
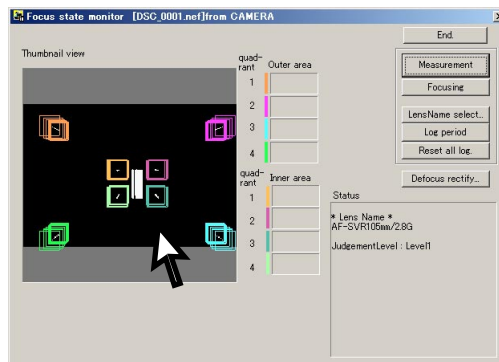
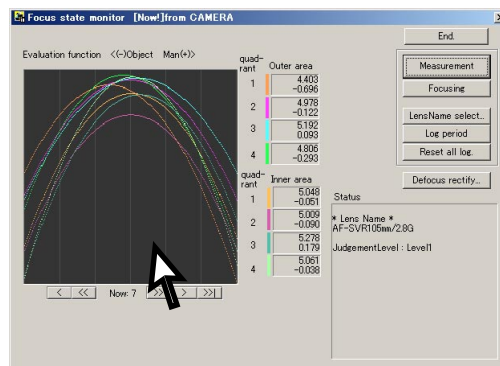
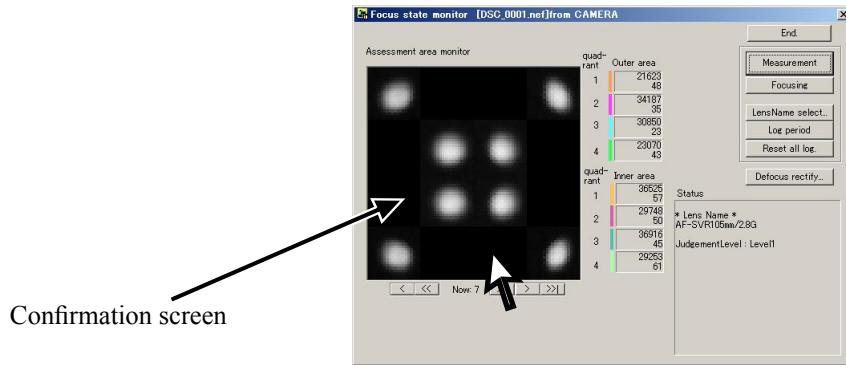

(4) 1-1st lens-group alignment (for periphery)

Caution: As for products lens, the screwlock is applied around four screws (#142) and the 1-1st lens group. So wipe the screwlock as far as possible with alcohol, etc, then work on the lens alignment.

- ① Give the four knobs of the 1-1st lens-G alignment tool (★ J11327) about half-turn counterclockwise from the position where the knobs are screwed completely.
- ② Give the retaining ring of [★ J11327] about two-turns counterclockwise from the position where the retaining ring is screwed completely.
- ③ Screw [★ J11327] all the way in the filter ring of the lens. Then turn it counterclockwise until the four knobs of [★ J11327] are positioned like "X" when viewed from the front. (ref. Pic. 1)

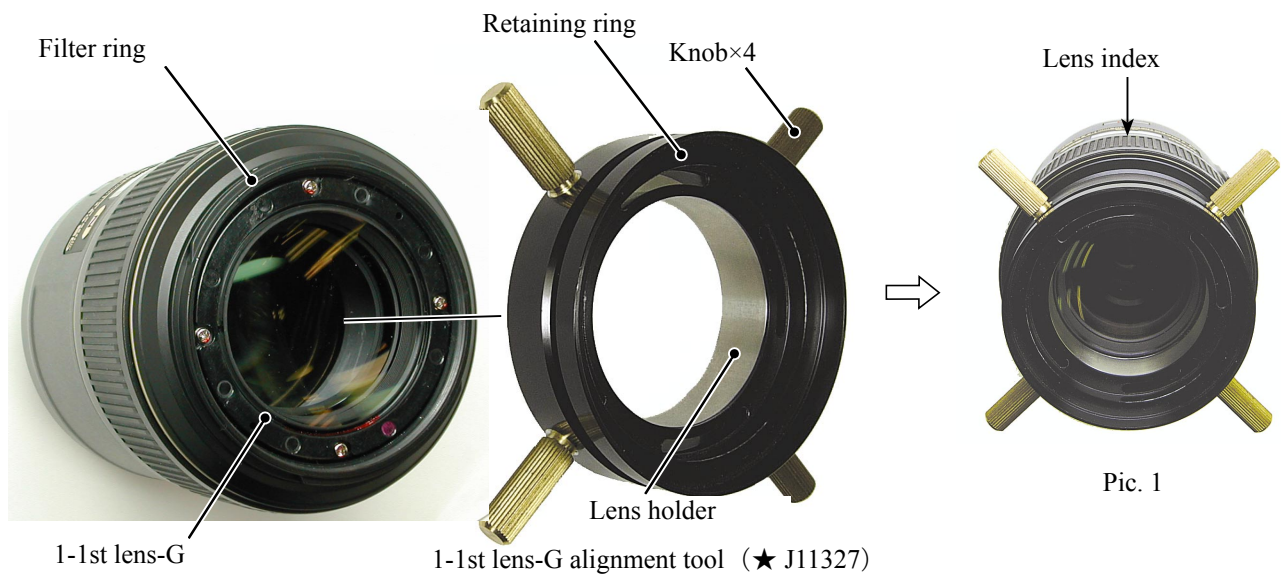

- ④ Rotate the retaining ring until the four setscrews (#142) of the 1-1st lens group can be seen.
[The slightly loosened retaining ring is acceptable at the place where the four screws (#142) can be seen.]

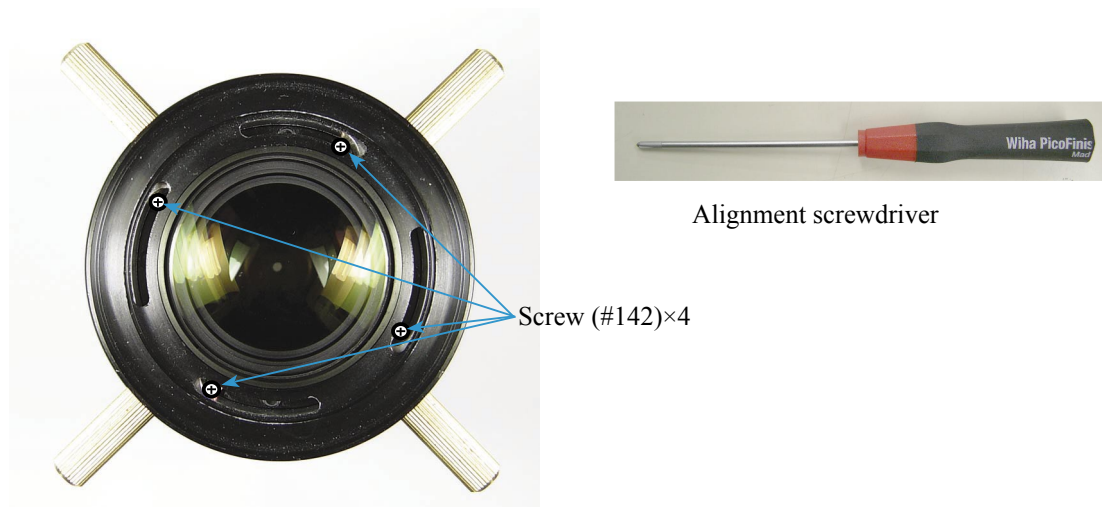

- ⑤ Screw each four knobs of [★ J11327] evenly, and stop screwing until they touch the lens holder.
- ⑥ Loosen the four screws (#142) with the alignment screwdriver.

- ⑦ According to the result of "Information display" of the adjustment software, which was performed in the chart shooting of (3), select from the below pictures A ~ D, and rotate the knobs of the 1-1st lens-G alignment tool (★ J11327).

(At first, rotate the knobs at an angle of approx. 45 degrees. Then shoot the chart and check the image.)

Caution) The method of the rotation is the same as the operation of the 5th lens-G alignment tool (★ J11328) [i.e. ⑭ of (2)].

A. In case of "X directions:-1"



B. In case of "X directions:+1"

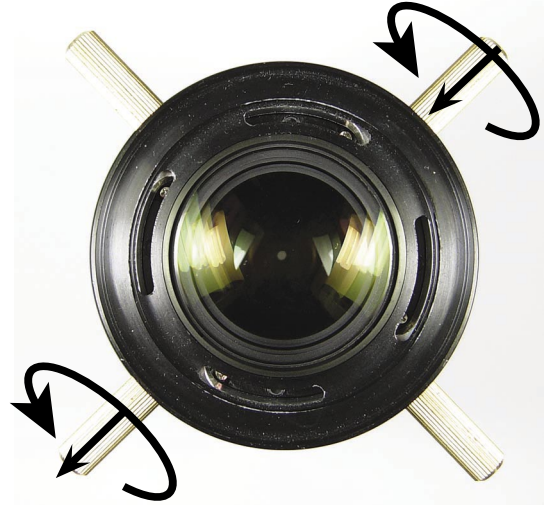

C. In case of "Y directions:+1"



D. In case of "Y directions:-1"



- ⑧ Tighten the four set screws (#142) of the 1-1st lens group.

⑨ Perform [(3) Chart shooting for the 1-1st lens-G alignment (for periphery)] again, and repeat the procedure (3) and (4) until the information display of the software indicates "END".

⑩ Tighten the four screws (#142) and remove the 1-1st lens-G alignment tool (★ J11327) from the lens.

Caution: After removing [★ J11327], shoot the chart of (3) again and confirm that the information display indicates "END".

⑪ Apply the screwlock on the four screws (#142) and the 1-1st lens group.

Reference :

When the chart is shot in the above ⑨ , before sliding the tripod to the front by 18 cm and shooting seven times, click "Focusing" button and check the following screen.

If ⑥ - ⑧ is performed so that the point images' shape of periphery becomes about the same and also that of center becomes about the same, this will shorten the alignment work.

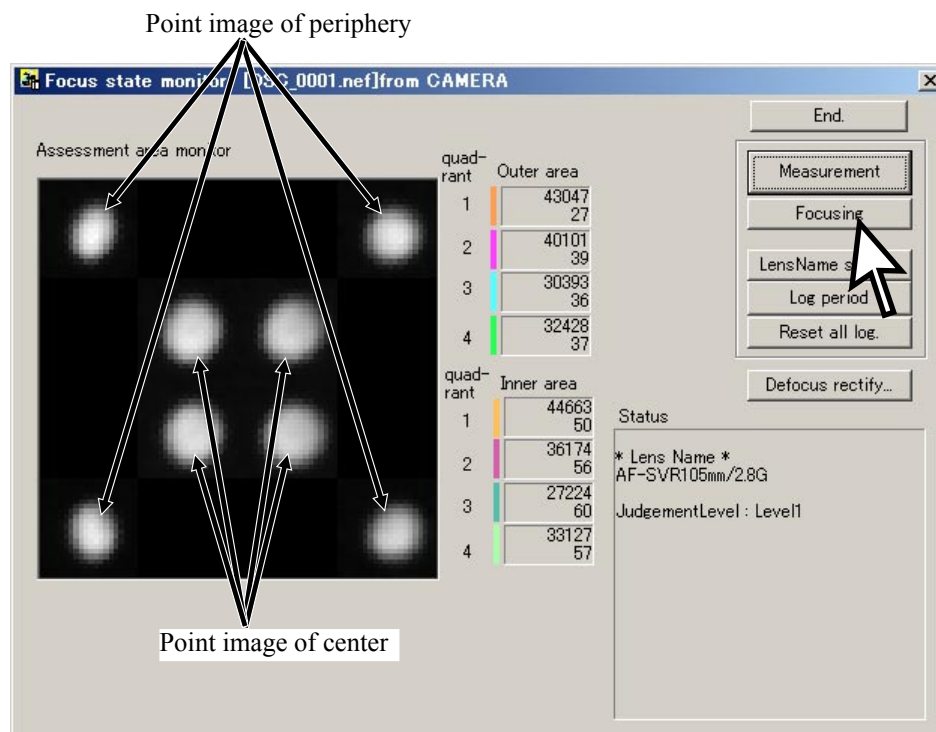

How to create Setting board of "Lens alignment chart" and "Viewer"

1. Summary

1-1: In order to get necessary data for lens alignment, this board is created to use for setting a special chart and light viewers (for chart illumination), while taking pictures of the special chart with a digital camera.

2. Preparation

2-1: Prepare a board (760 x 880 x 20 mm) or 2 package cardboard boxes (size 2.33).

(Note) Because you have to cut out the shape to embed light viewers, choose package cardboard boxes (size 2.33) or material which can be easily cut. — ref. Fig. 1

3. Procedure (In this document, 2 package cardboards are used)

3-1: As for the 1st flattened cardboard box (size 2.33), check the positions for embedding the light viewers, and cut out the shape at 5 locations (shaded parts/size 154 x 245 mm) as shown below. — ref. Fig. 2

(Note) Cutting the shape slightly smaller than the actual size of viewers makes it easier to fit the positions of viewers tightly.

3-2: Put the 2nd flattened cardboard box (size 2.33) and the above cut-out 1st cardboard together as one, and fix them by taping at 4 sides. — ref. Fig. 3

3-3: Then as for the 2nd flattened cardboard box, cut out the shape again by matching the cut-out size of 3-1 for each viewer. — ref. Fig. 4

3-4: Reinforce the edges of cut-out parts with tape.

(Note) To prevent viewers falling off, secure them with tape around the edges. — ref. Fig. 5

3.5: **Blacken around the setting board (with black spray, etc).**

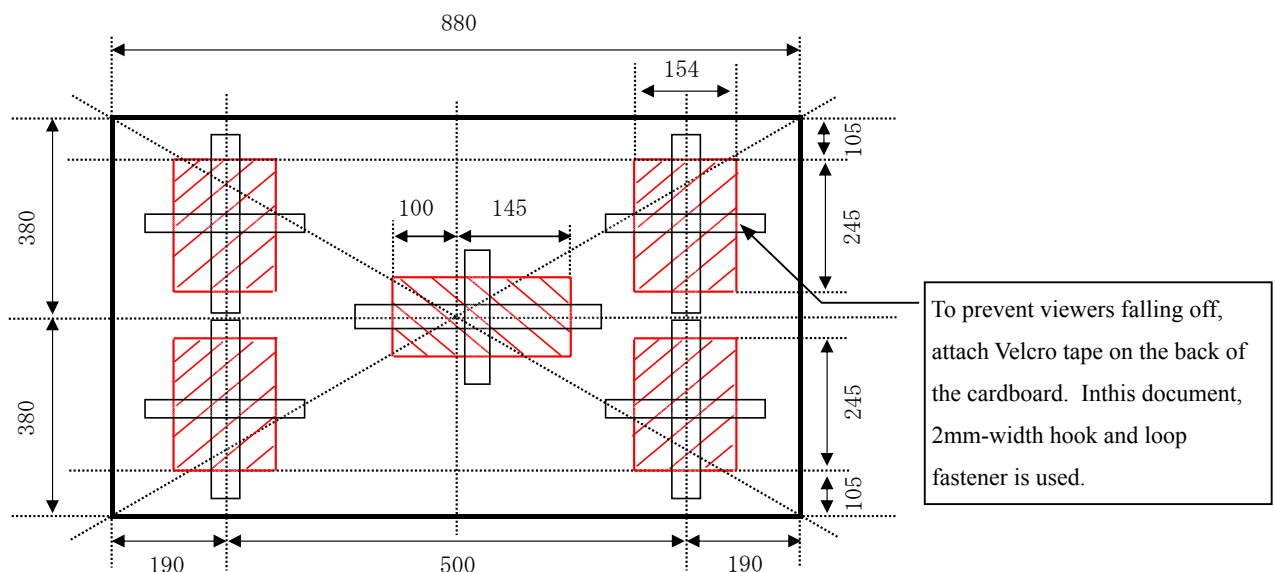

4. Prevent Viewers from falling off (In this document, 2-mm width Velcro tape is used.)

4-1: As shown above, when viewers are embedded, secure them with square pieces of Velcro tape (hook and loop fastener) on the back of the cardboard to prevent viewers falling off.

(Fig. 1- Prepare two package cardboard boxes, and flatten them as below.)



(Fig. 2 - As for the 1st flattened cardboard box, cut out the <154 x 245 mm sized> shape at 5 locations.)

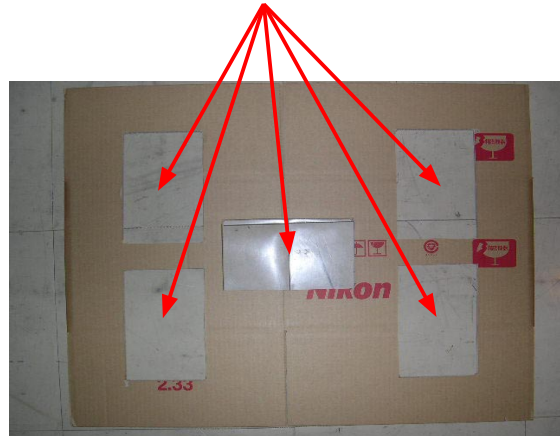

(Fig. 3- Package cardboard boxes)

Put the 2nd flattened cardboard box and the 1st cut-out cardboard together as one as shown below.

Fix them by taping at 4 sides.

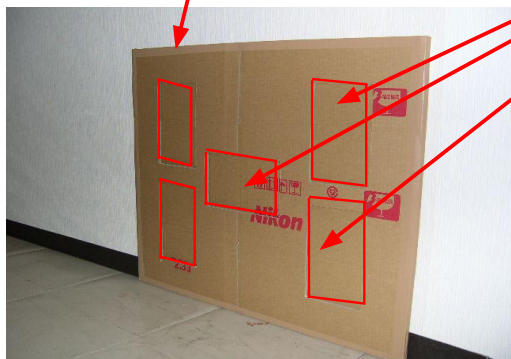

(Fig. 4- As for the 2nd flattened cardboard box, cut out the shape in the same way as Fig.2. All cardboards are cut out as below.

Cut out by matching the size of the 1st cutting.

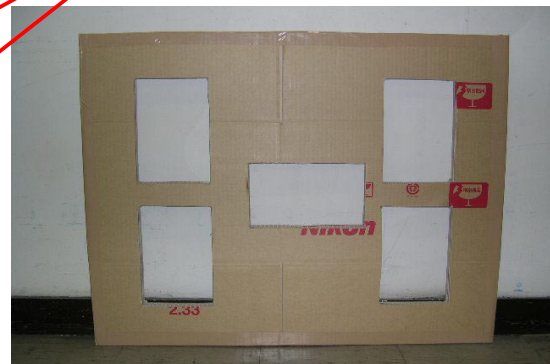

(Fig. 5- Light viewers are embedded.)



To prevent viewers falling off, secure the viewers with tape around the edges.

(Fig. 6- Setting board is blackened with the chart being attached.)



F.F.D (flange focal distance)/Backfocus Adjustment
--

★ : New tool

- ① Take out the screw (#132) of the change-SW unit, and slacken the change-SW.
- ② Set the focus ring to the infinity (∞).
- ③ Insert the infinity positioning pin (★ J11319) into the "A" hole.

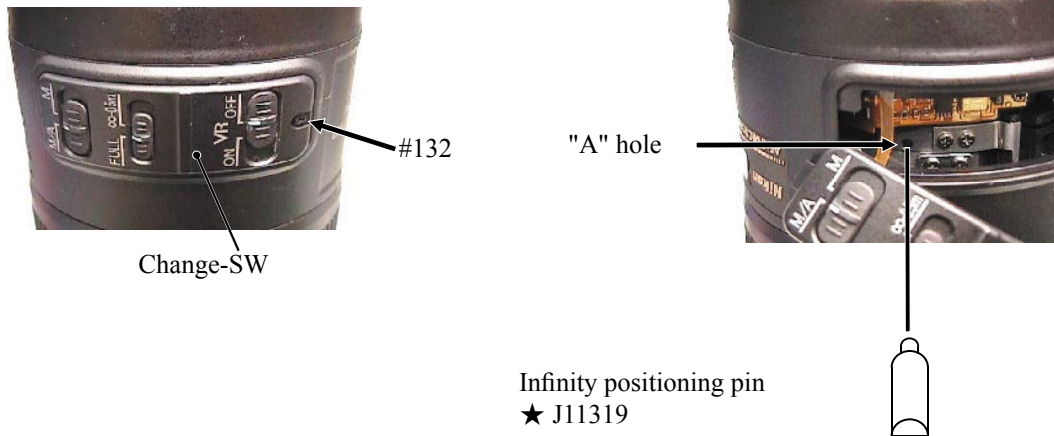

- ④ Insert a suitably-sized cut heavy paper or plastic, etc, into the 3.1-aperture lever so that the aperture becomes full open.
- ⑤ Set the lens on the lens adapter for focus tester, and measure "M.B.f" value by the back focus collimator LT-500S (J19002).
- ⑥ In case the result is out of standard, remove the bayonet mount and the washer (#176).
- ⑦ For a difference between the value (⑤) and the standard value, adjust the thickness by selecting the washers (#176: selected from A ~ M).
(In the difference is positive, increase the washers. If it is negative, decrease the washers.)

Standard: 0 ± 0.05 mm

- ⑧ In case the result is within standard, confirm the " ∞ " alignment by the horizontal-type collimator.

Standard: Center of (∞)-mark $\pm 2/3$

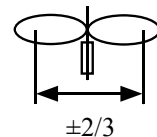

Caution:

In case the back focus collimator LT-500S (J19002) is not available, use a horizontal-type collimator to confirm " ∞ " alignment, and select the above washers for the adjustment.

VR adjustment

When making the VR adjustment, refer to the "Instruction Manual" that is attached to the VR lens adjustment equipment (J15380).

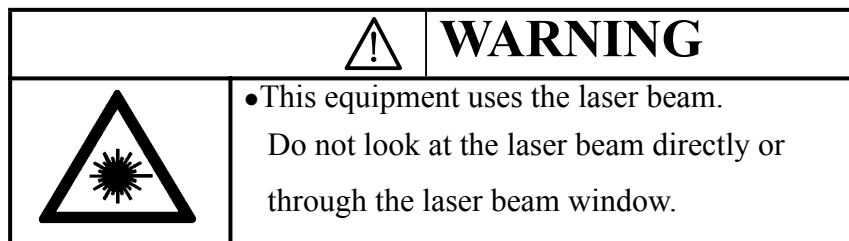

Preparation

- ① Set up the VR lens adjustment equipment (J15380) as shown below.
- ② Connect the personal computer to the equipment and start the PC.
- ③ Mount the lens on the equipment. Set the infinity (∞) mark of the focus ring to the index.
Refer to the next page for "Procedure for mounting the lens".

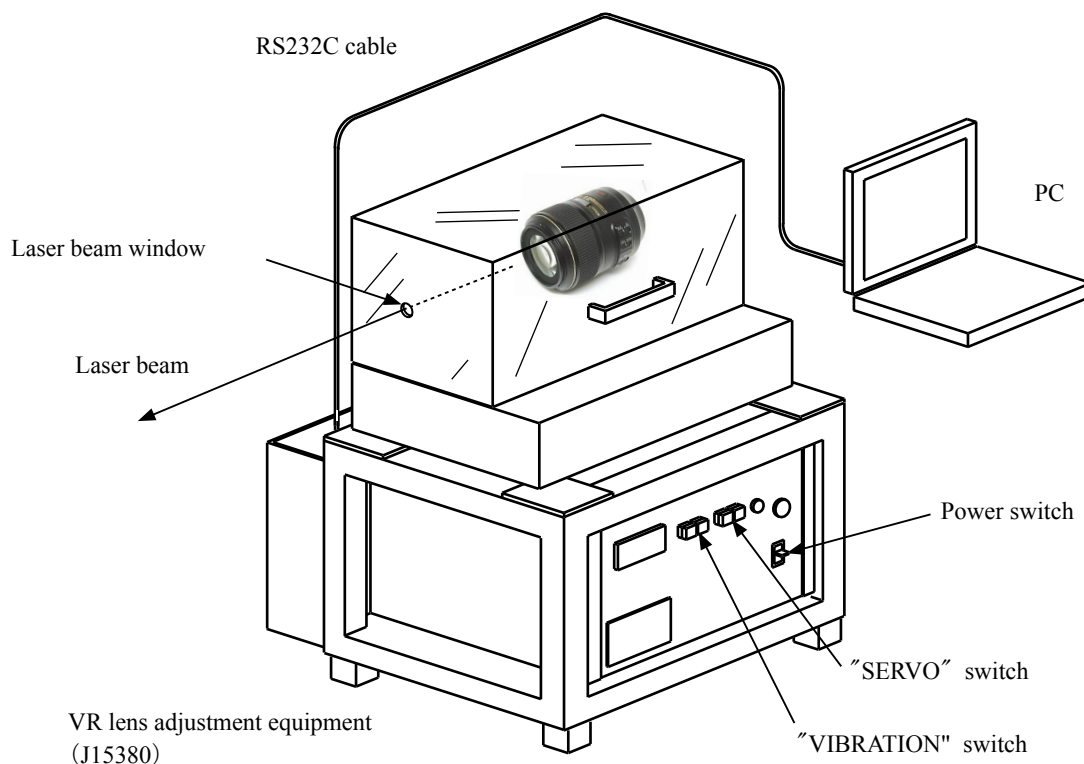

Notes: Keep the approx. 5-m distance from the laser beam window to the radiated surface.
Do not block the light path of the laser beam.

Procedure for mounting the lens

1. Mount the lens on the equipment and move the lens retainer stand in the direction of the arrow.

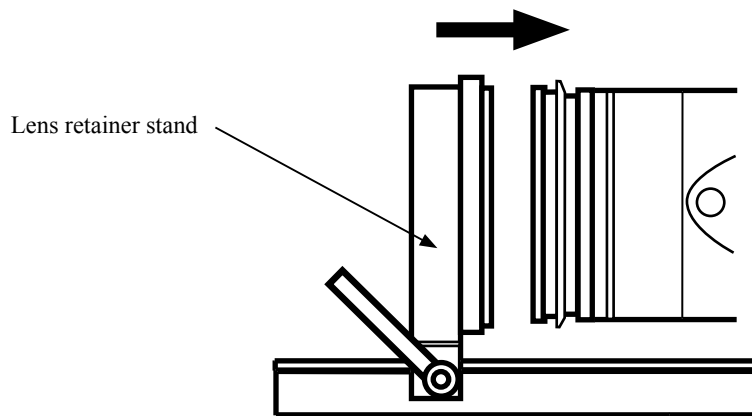

2. Move the lens retainer stand to the position as shown below and fix it by tightening the clamp.

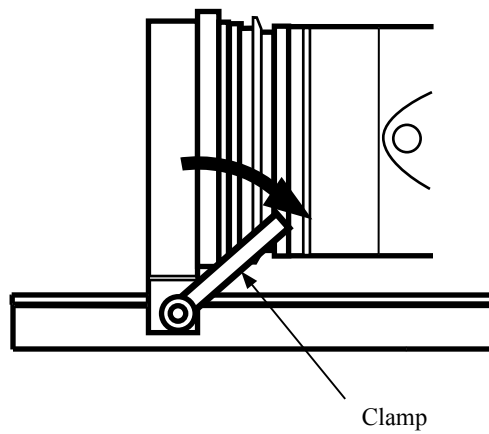

- ④ Turn the VR lens adjustment equipment (J15380) ON and start the adjustment software.
- ⑤ Point the cursor to "AF-S VR MICRO 105/2.8G" on the Lens selection screen and click it.

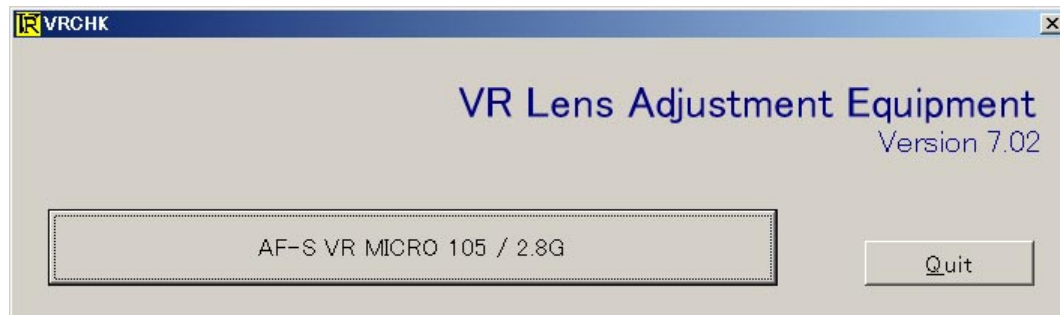

- ※ If the below message appears, reset the zoom ring by referring to "Procedure for mounting the lens" on the previous page. Then click "OK" button.
The focus ring is automatically set.

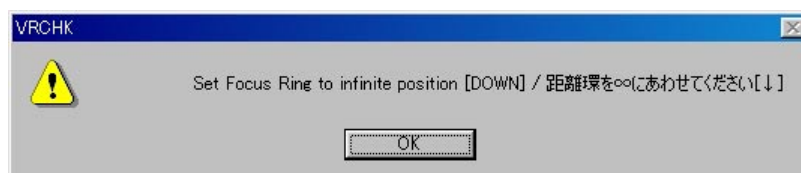

Note: Do not change the lens settings (zoom ring), until the adjustment is completed and go back to the Lens selection screen.

If the setting position changes during the adjustment, the correct adjustment value cannot be obtained.

Vibration Reduction mode switch inspection

- ① Point the cursor to the check box before "VR Mode Switch Inspection" and click it.
- ② Point the cursor to the "Execute" button and click it.

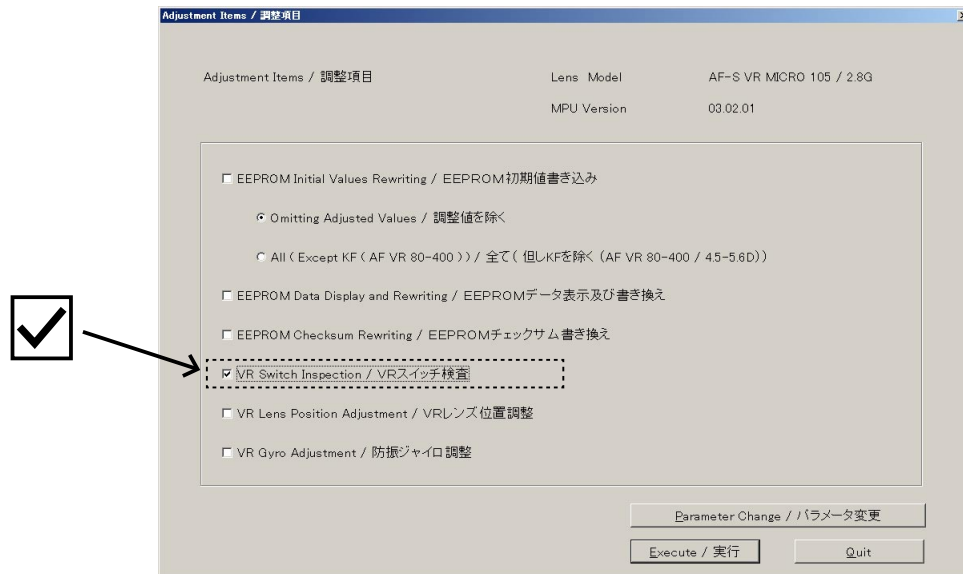

- ③ "VR Mode Switch Inspection" screen appears.



- ④ The position of VR mode switch is indicated.

Selecting the VR mode switch indicates the current position in the real time.



VR mode switch



- ⑤ When completing the VR mode switch inspection, point the cursor to "Exit" button and click it to exit the inspection screen.

VR lens position adjustment

- ① Point the cursor to the check box before "VR Lens Position Adjustment" and click it.
- ② Point the cursor to "Execute" button and click it.

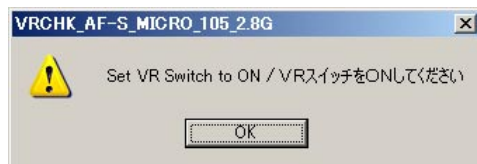
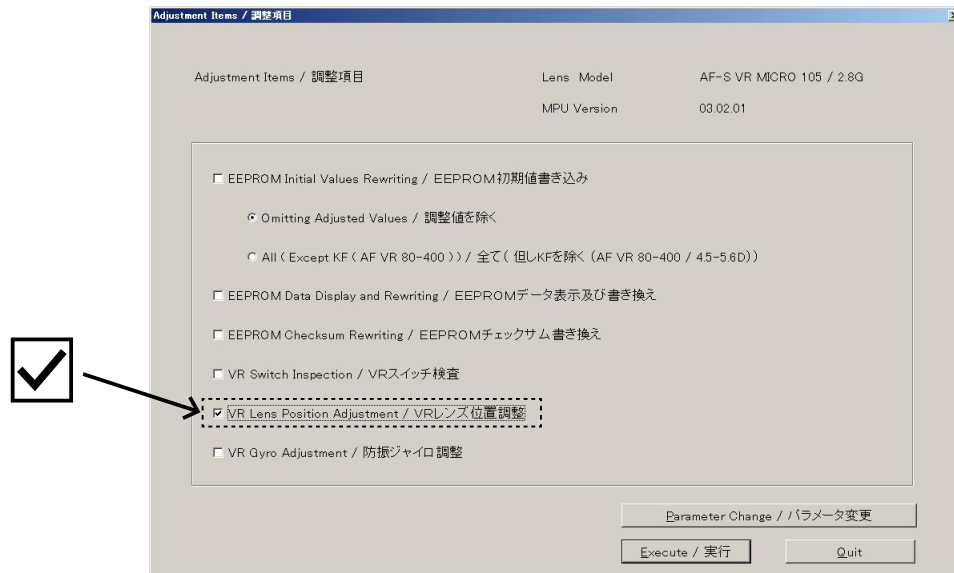

- ③ The left message appears.

Turn the VR mode switch of the lens to ON, then point the cursor to "OK" button and click it.

• VCM Polarity Adjustment (Automatic control)

Get the polarity of the VCM (Voice Coil Motor) and write it in EEPROM as the compensation value. During the adjustment, the message appears to confirm the lens position of angle (0 or 90 degrees). Therefore, set the lens to the position and click "OK" button.

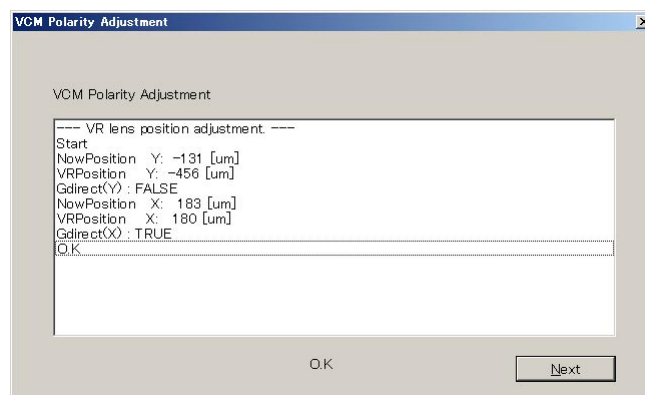

When "OK" is shown on the execution screen, point the cursor to "Next" button and click it.

- **Gamma and Shift Adjustment (Automatic control)**

Adjust the inclination and control center position based on the position sensor output of the VR unit.
During the adjustment, the message appears to confirm the lens position of angle (0 or 90 degrees).
Therefore, set the lens to the position and click "OK" button.

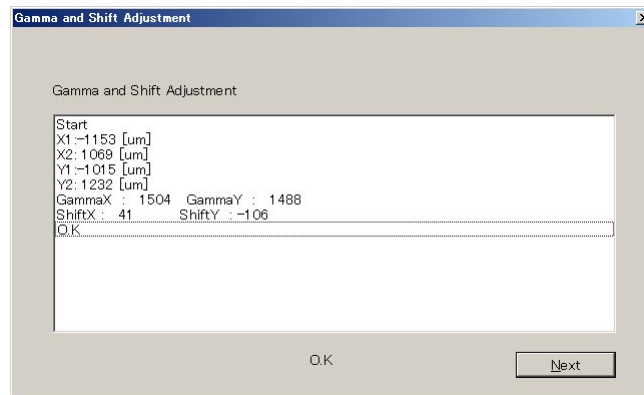

When "OK" is shown on the execution screen, point the cursor to "Next" button and click it.

- **Electromagnetic Lock Center Position Adjustment (Automatic control)**

Adjust the electromagnetic lock center position.
During the adjustment, the message appears to confirm the lens position of angle (0 or 90 degrees).
Therefore, set the lens to the position and click "OK" button.

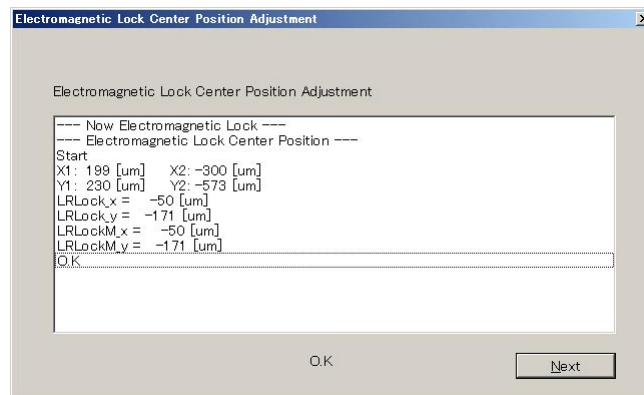

When "OK" is shown on the execution screen, point the cursor to "Next" button and click it.

The inspection mode starts automatically. When the following is displayed on the execution screen, point the cursor to "Next" button and click it.

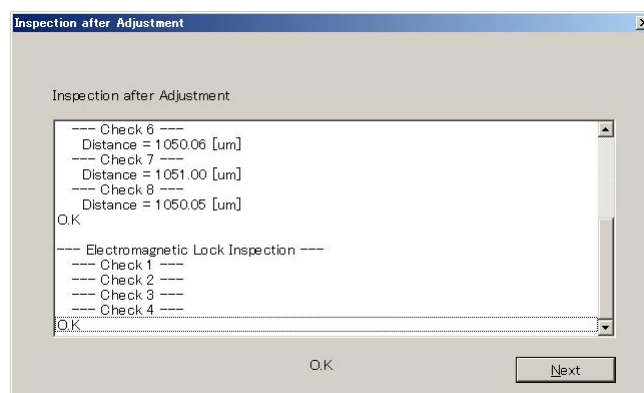

- Mechanical Lock Inspection

When the mechanical lock inspection is made, write the inspection result data as the adjustment value.

The below 1 and 2 screens are displayed alternately, so turn the VR switch to ON/OFF 5 times for the lens position 0 and 90 degrees respectively, according to the indicated instructions.

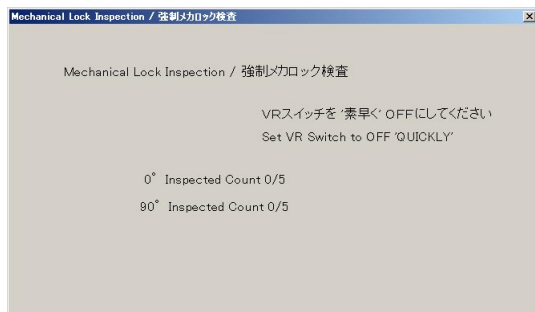

Screen 1.

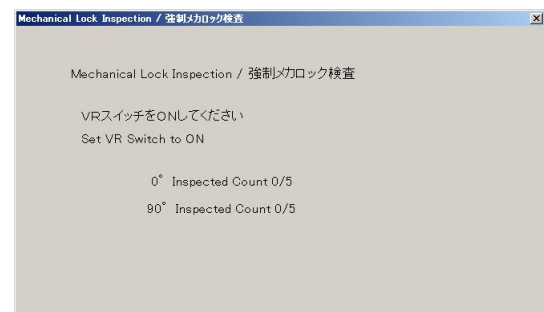

Screen 2.

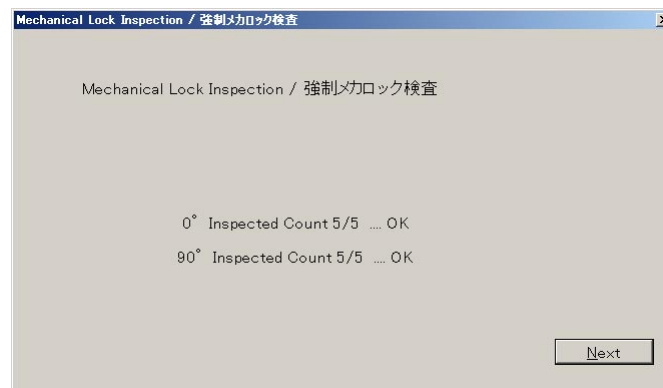

When "OK" is shown on the execution screen, point the cursor to "Next" button and click it.



- When the message "Finished rewriting checksum value" is shown, click "OK" button.

Turn the VR switch to OFF according to the message, and click "OK" button to exit the adjustment screen.

Note:

If "NG" is shown during the adjustment, click "Next" button to exit the inspection mode. Go back to the Lens Selection screen after rewriting the checksum value, and make the adjustment again.

If "NG" appears even after making the adjustment a few times, the VR unit, the gyro PCB, and the main FPC, etc should be defective.

VR Gyro Adjustment

- ① Point the cursor to the check box before "VR Gyro Adjustment", and click it.
- ② Point the cursor to "Execute" button, and click it.

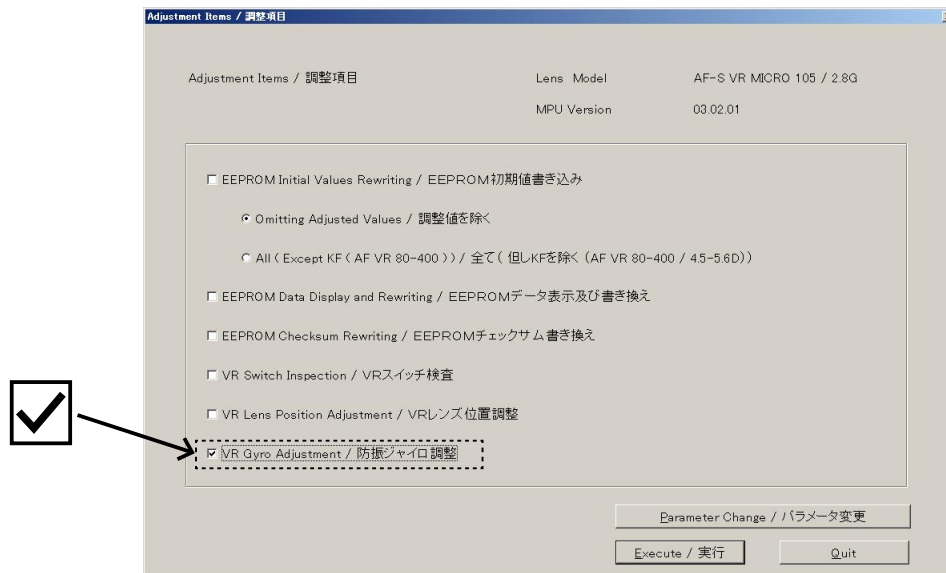

- ③ The left message appears.
Set "Frequency" of "Telephoto" to 5.0 Hz in the settings of the VR lens adjustment equipment (J15380).

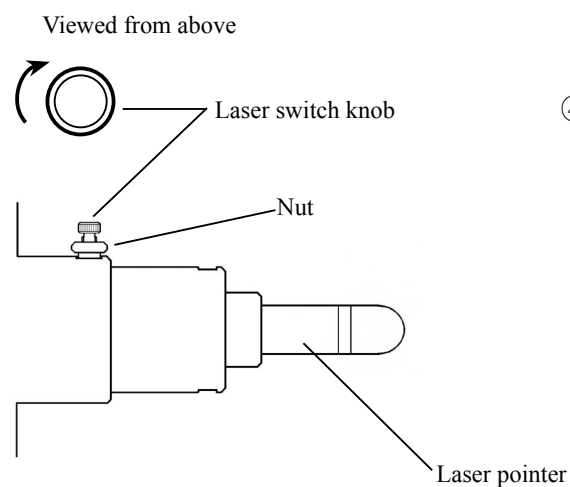

- ④ Loosen the laser switch nut of the VR lens adjustment equipment (J15380), and rotate the knob in the arrow direction to irradiate laser light.

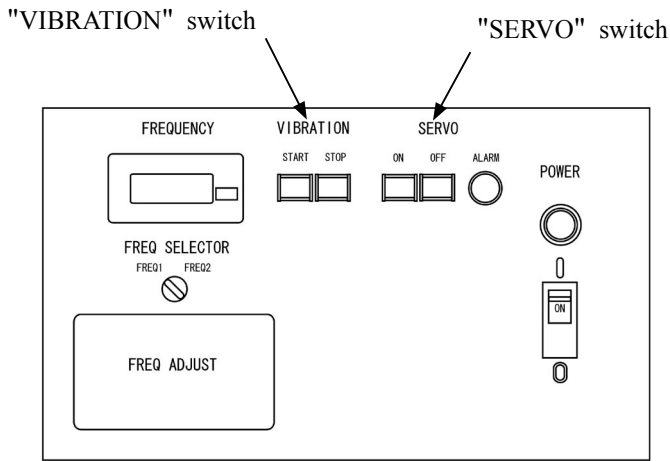

⑤ Press "ON" button for "SERVO" switch and press "START" for "VIBRATION" switch of the VR lens adjustment equipment (J15380).

⑥ When the equipment starts to vibrate, measure the vibration width (α) of the laser beam.

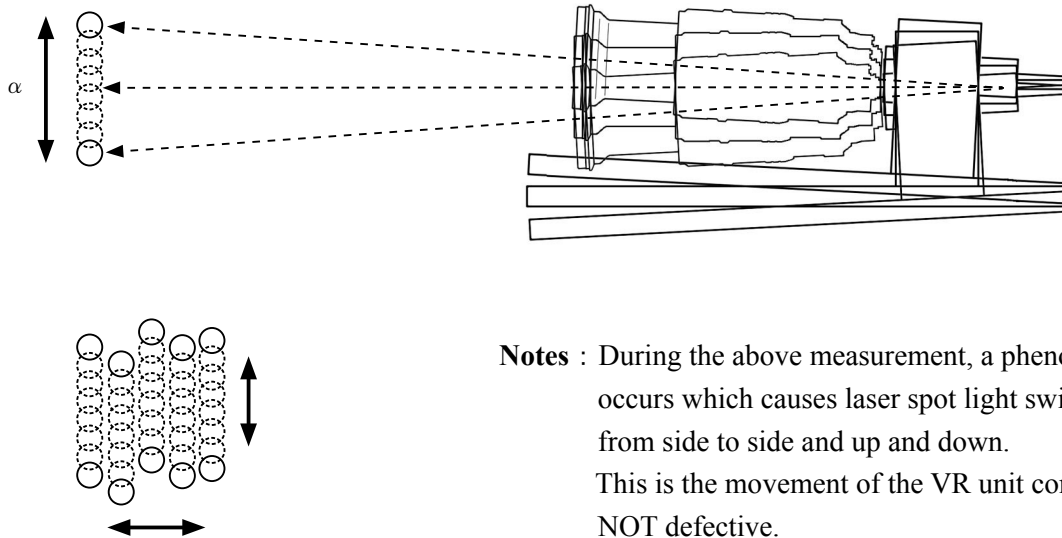

Notes : During the above measurement, a phenomenon occurs which causes laser spot light swinging from side to side and up and down. This is the movement of the VR unit control and NOT defective.



⑦ Point the cursor to "Next" button in the message box on the screen and click it. The vibration reduction function starts and the vibration width of the laser beam becomes narrow.

• Adjust misalignment of angle

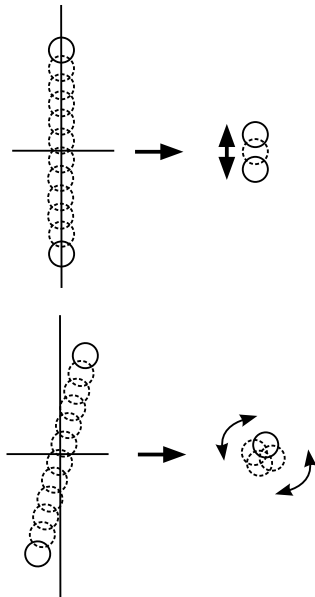

If the angle is misaligned, the laser beam source looks like turning around even after making the Gyro-gain adjustment.

If the angle misalignment is detected, adjust the misalignment by the adjustment buttons to correct it.

Note: After using the adjustment buttons, wait for a few seconds until the vibration movement stabilizes.

Buttons for adjusting "Gyro-Gain"

Buttons for adjusting "Angle misalignment"

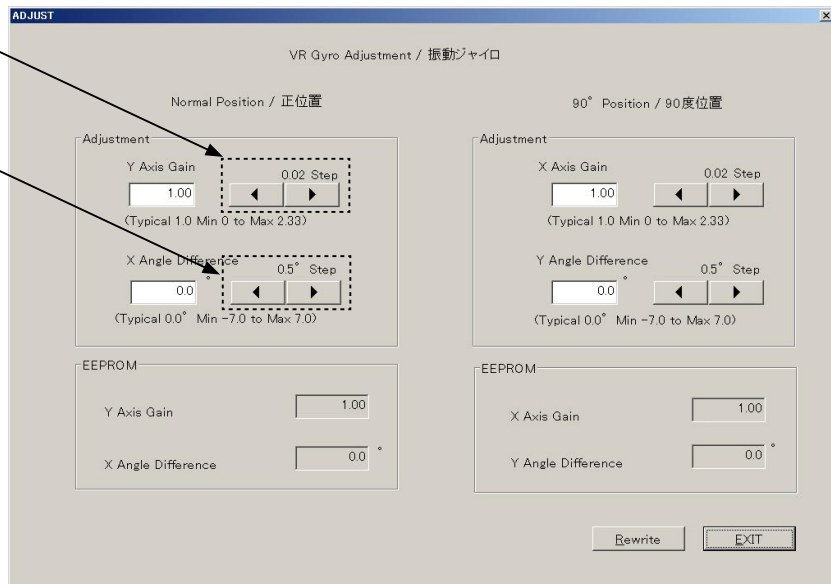

• Gyro-Gain Adjustment

Adjust the vibration width by the buttons for Gyro-gain adjustment so that the measured vibration width of the laser beam becomes 1/5 or less of the maximum width (α).

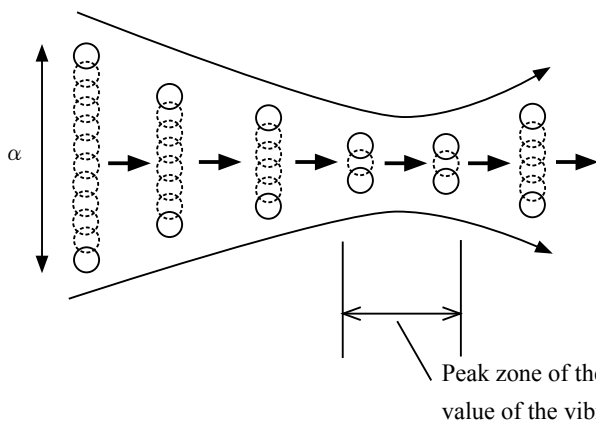

Standard:
Fifth part (1/5) or less of the vibration width (α)

Note: The laser beam vibrates widely again after passing the peak section of the minimum value.

《Ref.》

- The laser spot beam travels 5-m ahead, irradiating with spot of approx. ~~5 mm~~ in diameter.

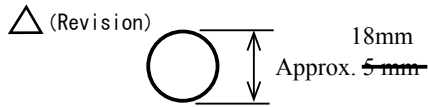

- ① The vibration width is adjusted at the center of the laser spot. First, measure the whole vibration width.

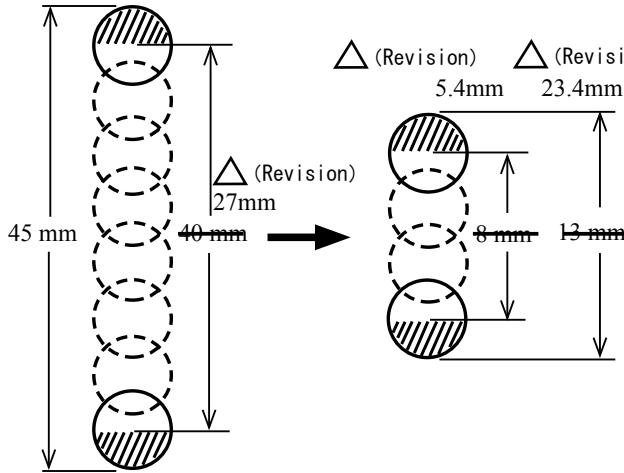

- ② Subtract the top and bottom radial parts (shaded areas) of the laser spots from the measured whole vibration width.

e.g.)
When the vibration width as a whole is "approx. 45 mm",

Vibration width of center is:

$$\cancel{45 - (2.5 + 2.5)} = \cancel{40 \text{ mm.}}$$

$$\triangle (\text{Revision}) \quad 45 - (9+9) = 27\text{mm}$$

Standard figure after the gyro-gain adjustment

$$\cancel{40 \times 1/5} = \cancel{8 \text{ mm}} \text{ (Vibration width of center)}$$

$$\triangle (\text{Revision}) \quad 27 \times 1/5 = 5.4\text{mm}$$

Vibration width as a whole is:

$$\cancel{8 + (2.5 + 2.5)} = \cancel{13 \text{ mm.}}$$

$$\triangle (\text{Revision}) \quad 5.4 + (9+9) = 23.4\text{mm}$$

- How to obtain the minimum value of the vibration width

- ① Measure the vibration width while changing the adjustment value that is set every 0.02-Step as shown below.
- ② The peak zone of the minimum vibration width can be obtained by the actual measured value.
- ③ The center of the peak zone becomes the adjustment value.

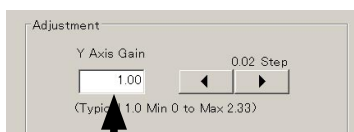

Gyro Gain Adjustment Value	Vibration width Actual measured value
.	.
.	.
0.90	15.5 mm
0.92	14.5 mm
0.94	14.0 mm
0.96	13.5 mm
0.98	13.0 mm
1.00	13.0 mm
1.02	13.0 mm
1.04	13.5 mm
1.06	14.0 mm
1.08	14.5 mm
1.10	15.0 mm
.	.
.	.

Note: Measure the vibration width in the half a millimeter (0.5 mm).



- Press "STOP" button of VIBRATION switch of the VR adjustment equipment to stop vibrations.
- Rotate the lens through 90° in the direction indicated by the arrow, then press "START" button of VIBRATION switch to start vibrations.
- At the 90° position, adjust the angle misalignment and make gyro-gain adjustment.

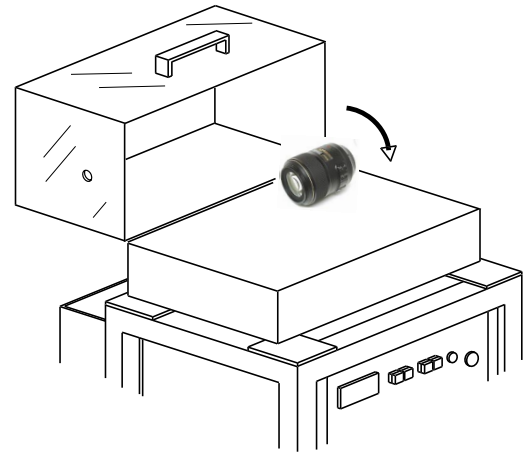

Note: When adjusting the lens at the 90° position, adjust by the buttons for the adjustment at 90° position as shown below.

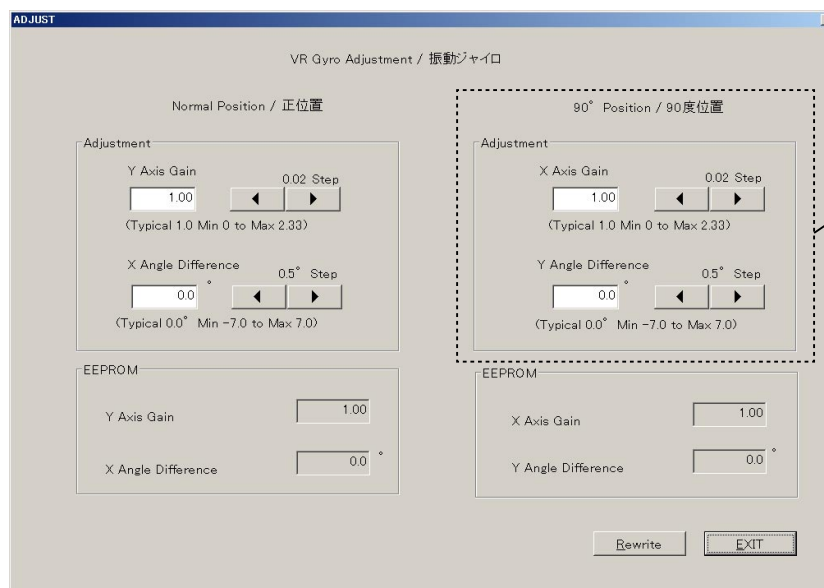

Buttons for adjustment at 90° position

- After the adjustment, click "Rewrite" button to write the adjustment value in EEPROM in the lens.
- Then, click "EXIT" button to exit the adjustment mode.

Note: If clicking "EXIT" button without clicking "Rewrite" button, the adjustment value is not recorded and the adjustment details are not written.

- Click "Quit" button on the adjustment items screen to go back to the Lens selection screen.

Note: Do NOT remove the lens or turn OFF the VR lens adjustment equipment until going back to the Lens selection screen. Otherwise, troubles may occur such as incorrect recording of the adjustment value due to blocked communications, etc..

Criteria for VR performance

Before making the VR adjustment of defective products by using the equipment, refer to the following.

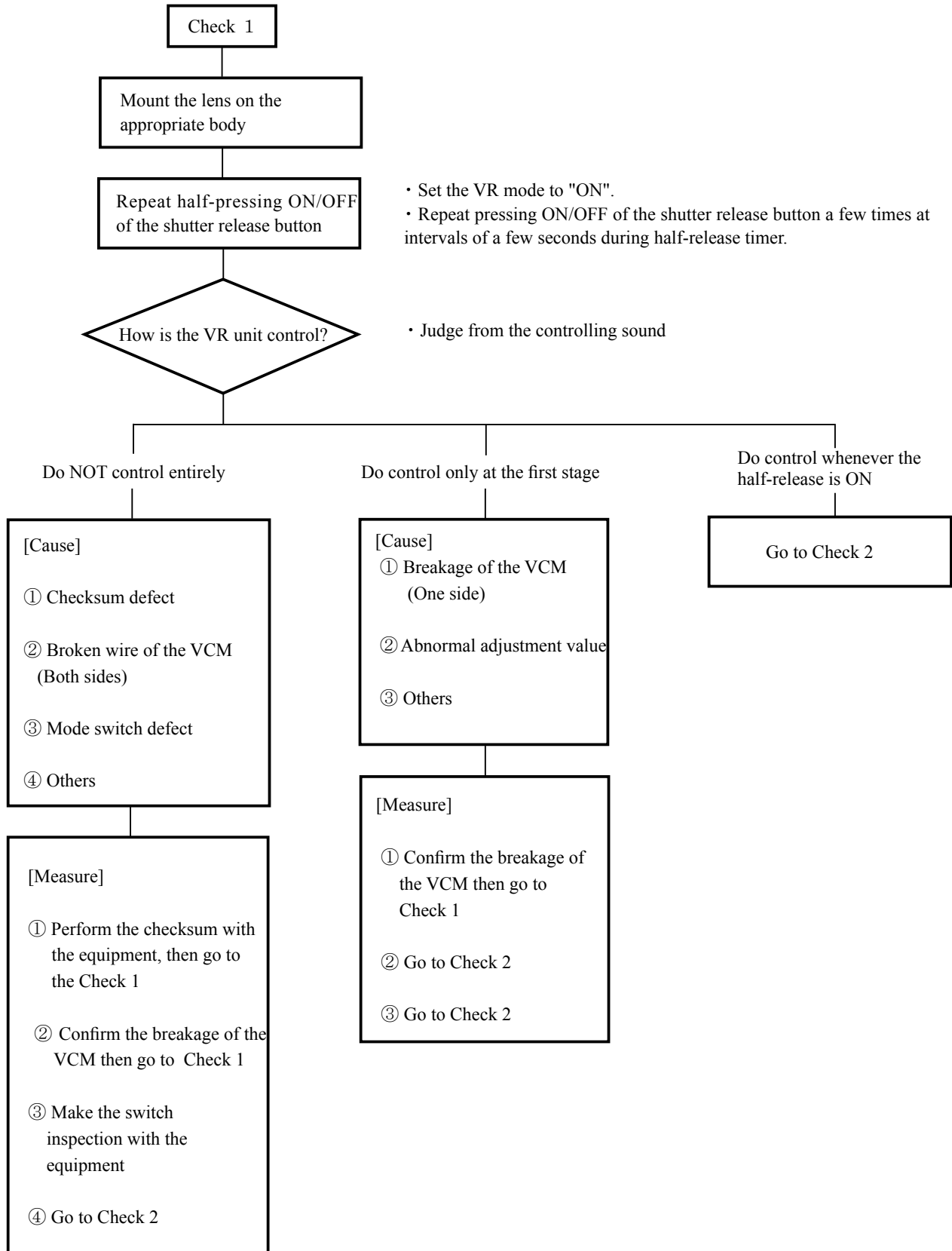

Go on the next page "Check 2"

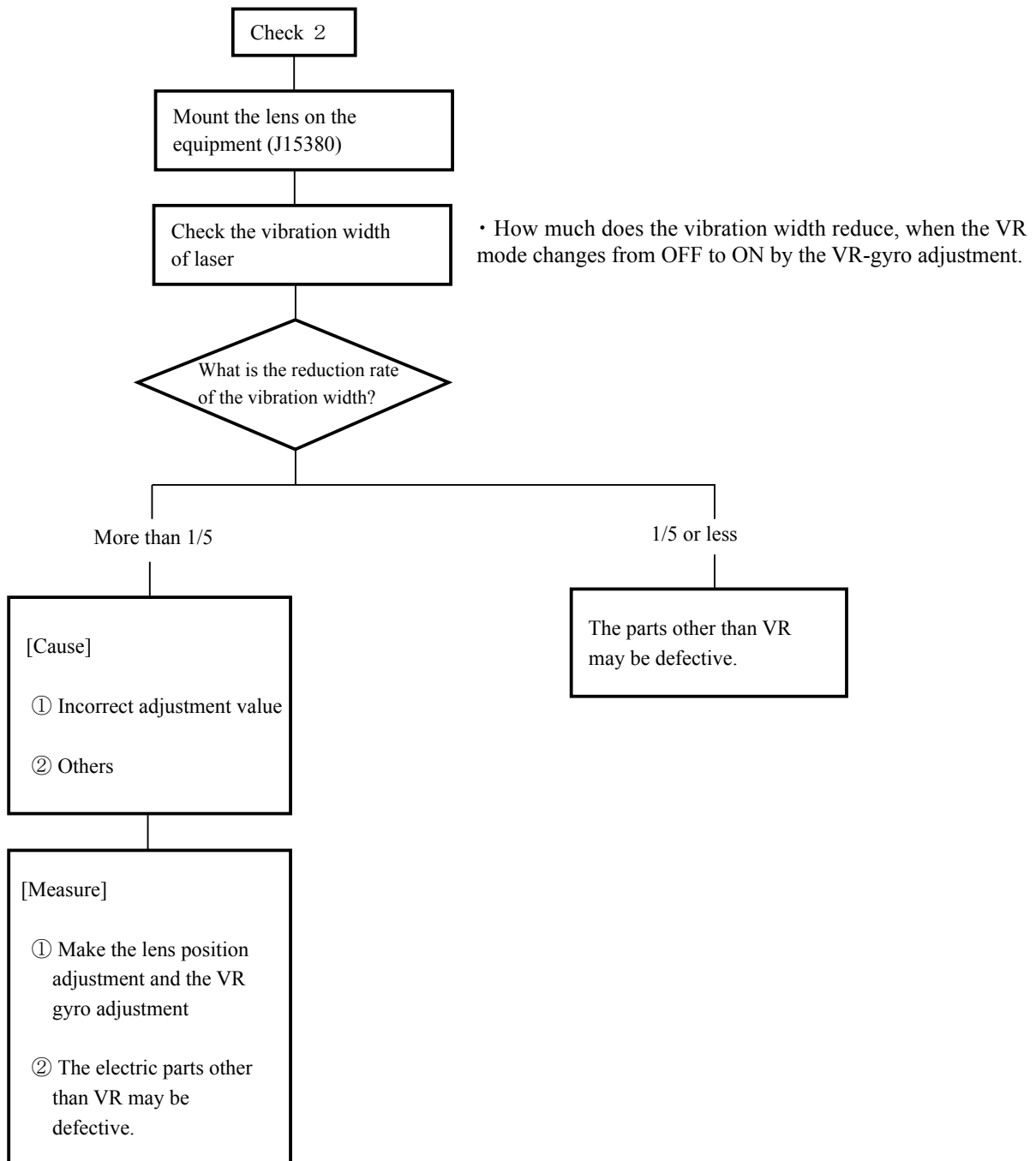

Rear cover ring

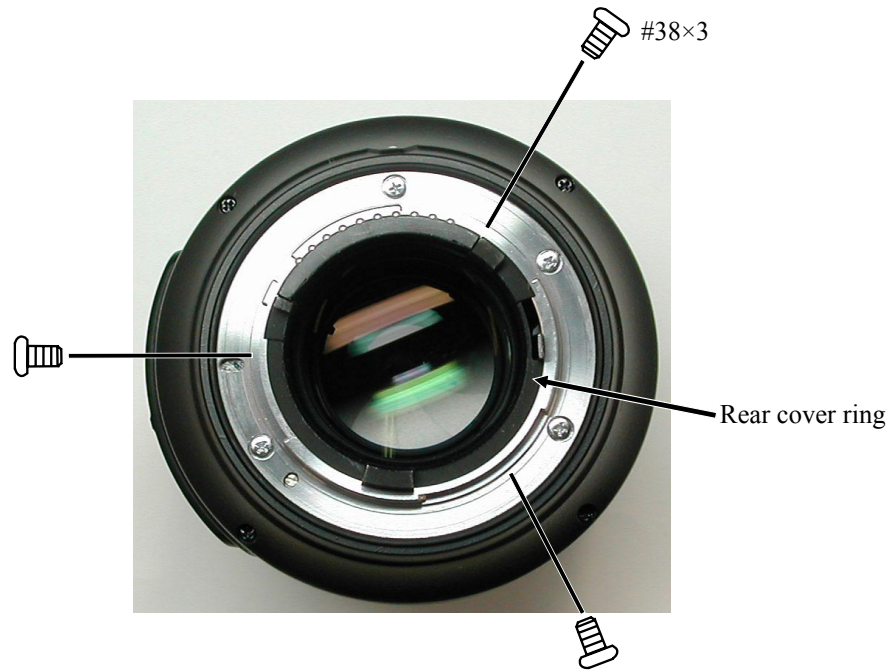

Front cover sheet

- Attach the front cover sheet.
(The front cover sheet already has the adhesive double-coated tape adhered.)



VR name plate

- Attach the name plate.
(The name plate already has the adhesive double-coated tape adhered.)



Aberration compensation data writing adjustment

- This adjustment uses the software which calculates the aberration compensation data according to the feature of lens aberration and writes in EEPROM of the lens, in order to improve the accuracy of autofocus.

Note: This adjustment is necessary when the main PCB and/or each lens part (glass, lens chamber) is replaced or when each lens part is disassembled. Be sure to make this adjustment after completing inspecting and adjusting the main PCB.

(1) Preparation

- Test chart (Self-made tool: ref. Procedure for how to create it.)
- Tripod
- D100
- Personal computer
- USB cable (UC-E4)
- Adjustment software (AFSVR105.exe : used for the lens optical alignment.)

(2) Procedure for how to create Test chart

- Photocopy the next page and cut out 1 target chart and 5 resolution charts.

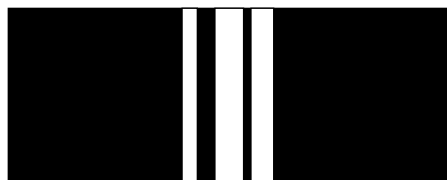

(Target chart)



(Resolution chart)

- As shown below, put each chart in position at the specified spacings.

Note: Only in the center, put the target chart on the central resolution chart.

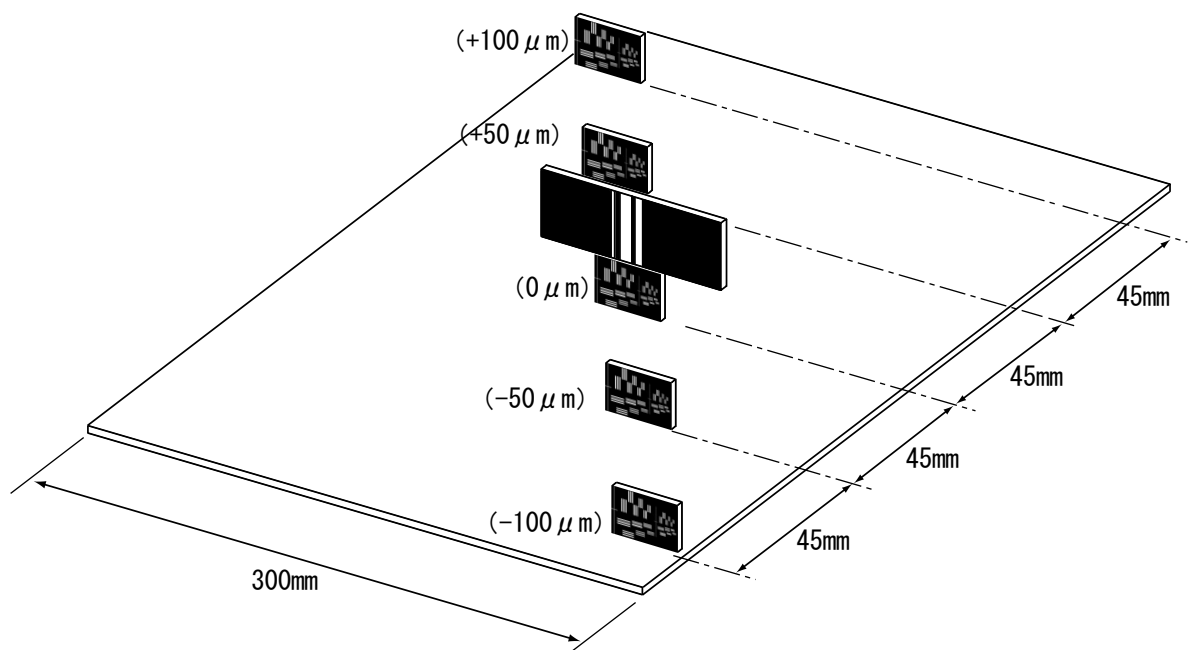

(Target chart)

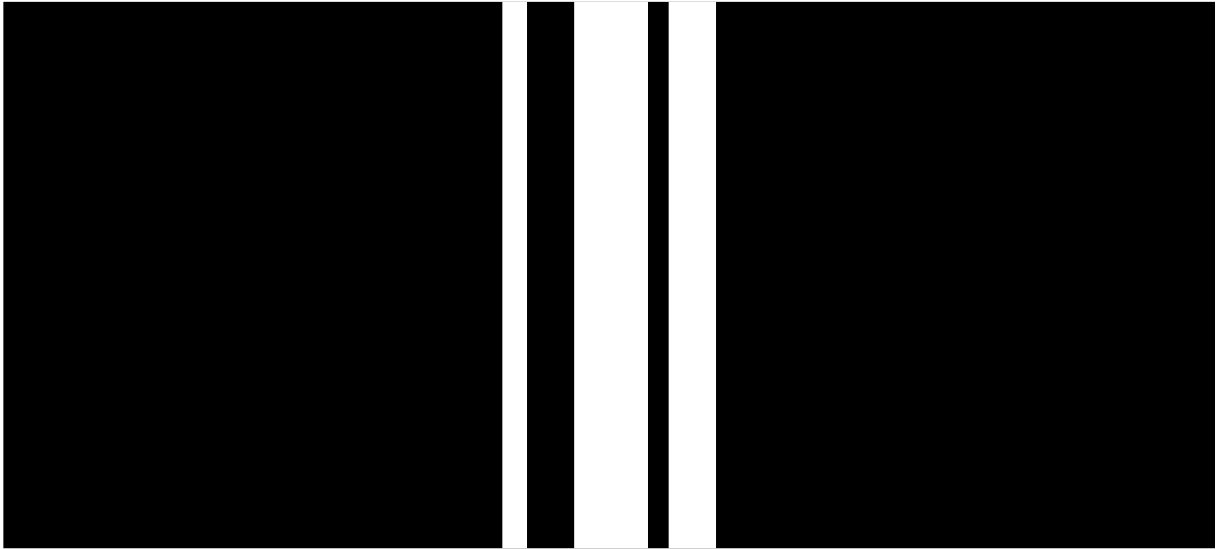

(Resolution chart)

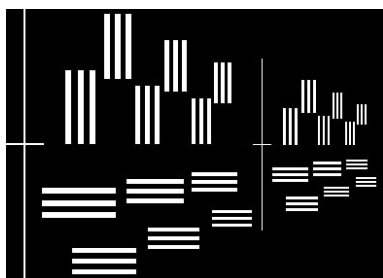
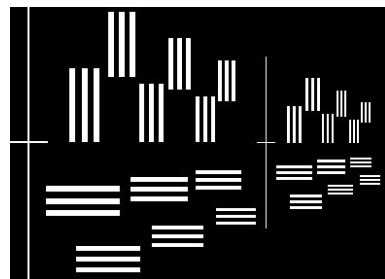
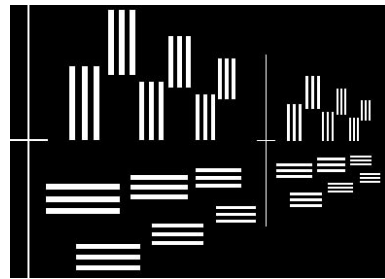
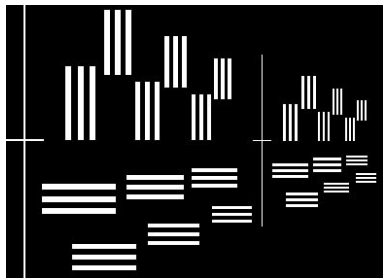

(3) Writing aberration compensation data

- ① Prepare a camera (D100). Set the "Exposure mode" to "A" for full aperture and "Focus mode" to "S".
On the shooting menu, set the "Image quality mode" to "FINE", "Image size" to "L", "WB" to "Preset", and "ISO" to "200".
- ② Set up the camera (D100), in which the lens to be inspected is fit, on the tripod. and the distance between the test chart and camera (CCD face) to $3\text{ m }15 \pm 2\text{ cm}$.

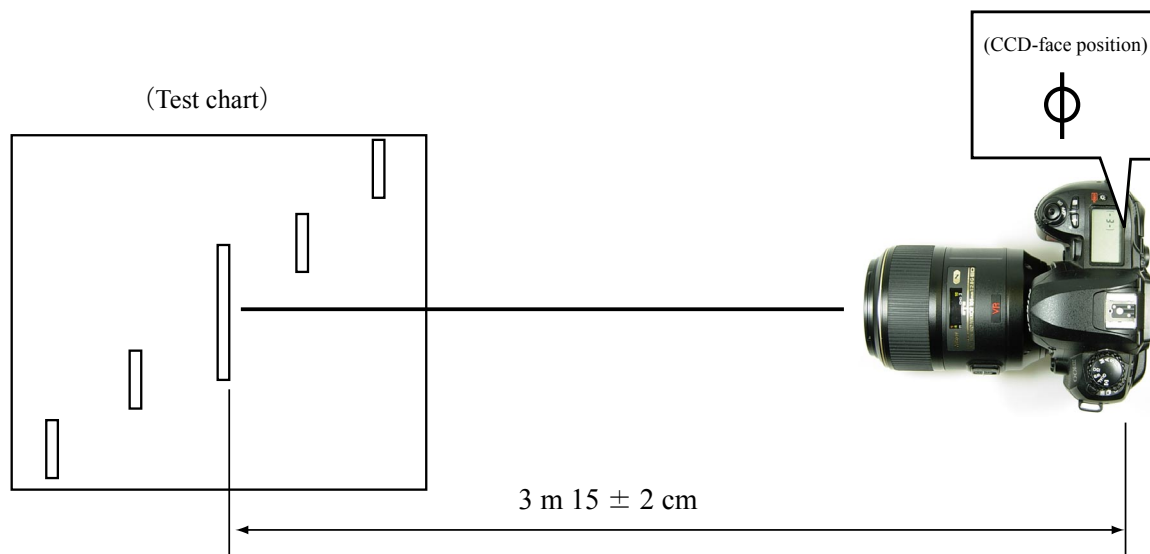

- ③ As shown below, set the center of the focus area on the chart within viewfinder.

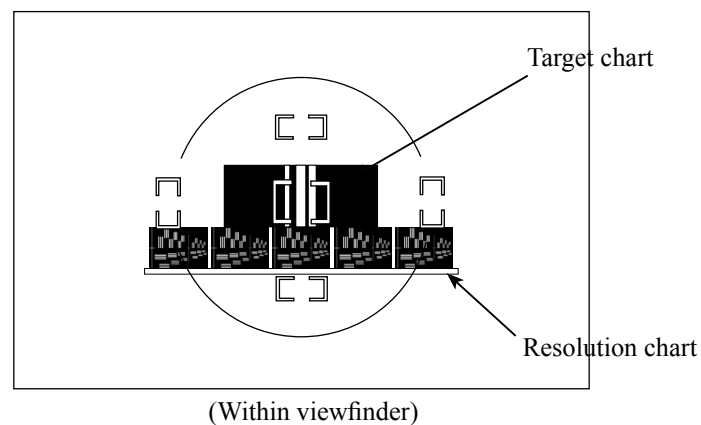

- ④ Connect the PC and camera via USB cable. (Camera setting: Mass storage)
- ⑤ Start the adjustment software (LWM.exe).

- ⑥ Confirm that "AF-S VR 105/2.8G" is selected on "Lens select" screen. Click "OK".

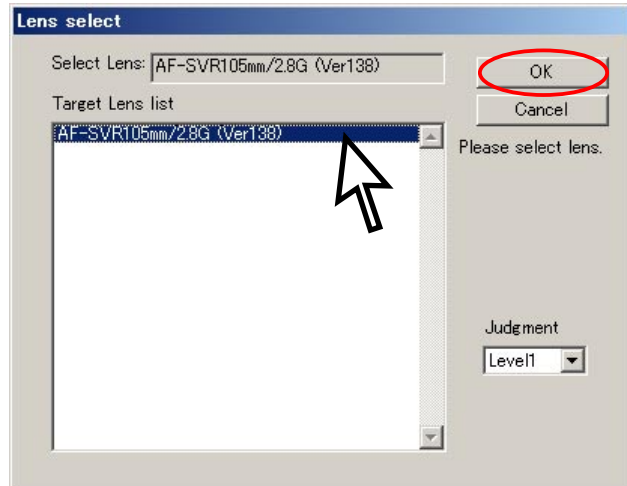

- ⑦ Click the "Defocus rectify..." button.

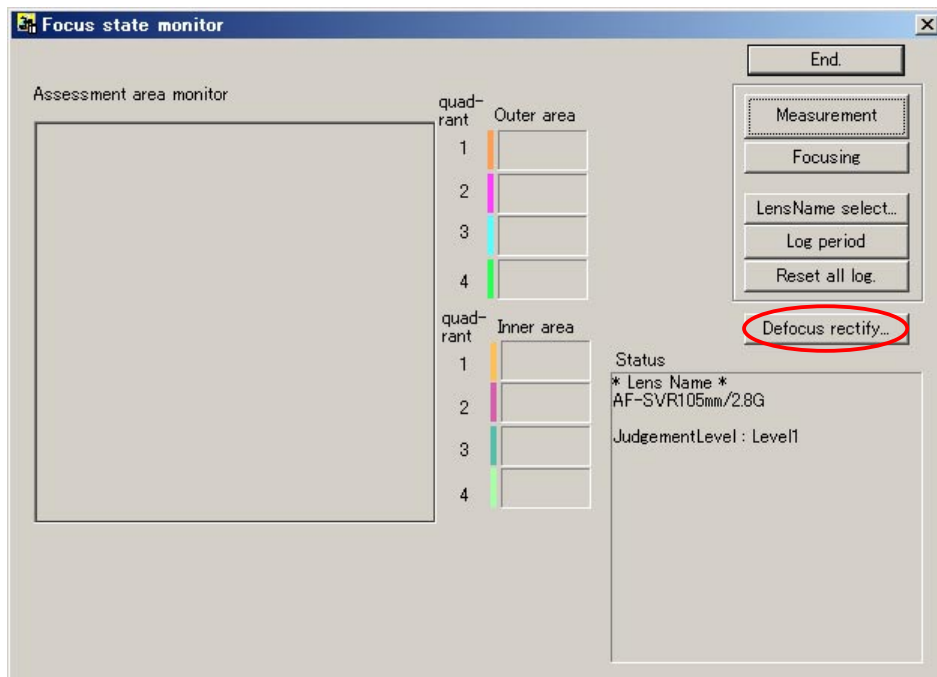

- ⑧ Click the "JPEG Shot" button.

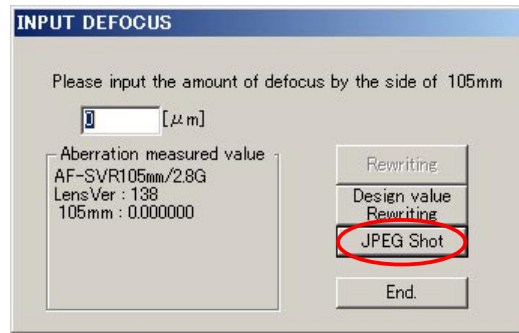

- ⑨ The shutter is released after the AF operation. The shot image is automatically displayed on the PC screen.

Scale the image to 100% and check which chart is in focus of the 5 resolution charts.

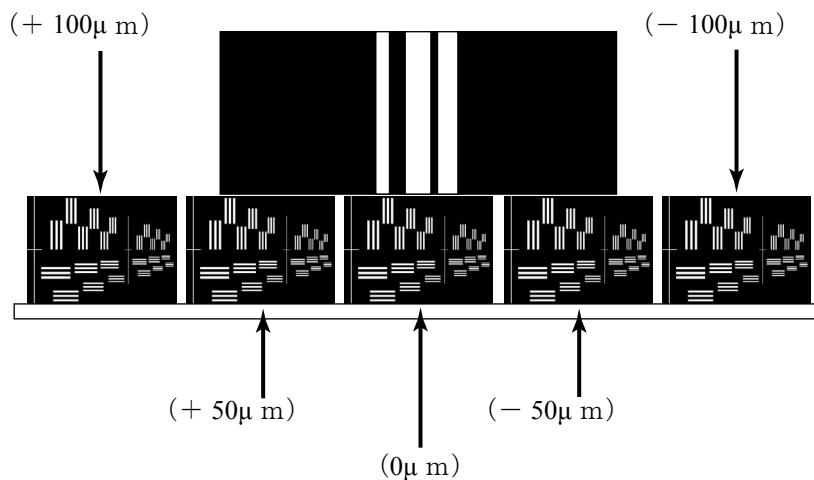

- ⑩ Input the value of the focused position into the entry field.

e.g. The below is the case when " $-50\mu\text{m}$ " of the front focus side is in focus.

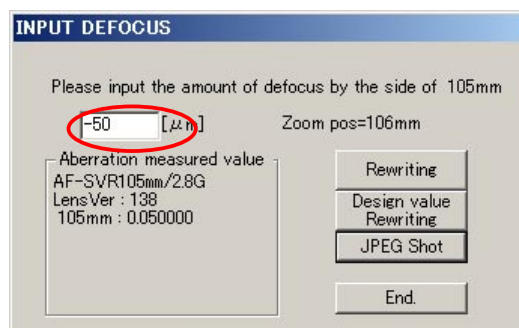

⑪ Click on "Rewriting".

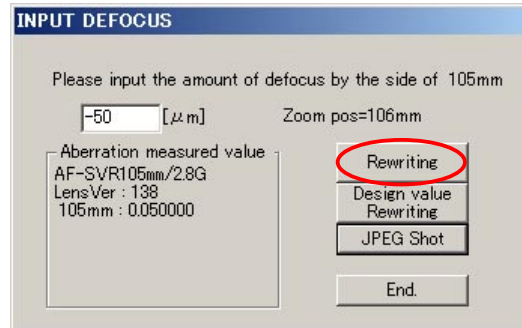

⑫ When "A compensation value is written in." is displayed, click "OK".

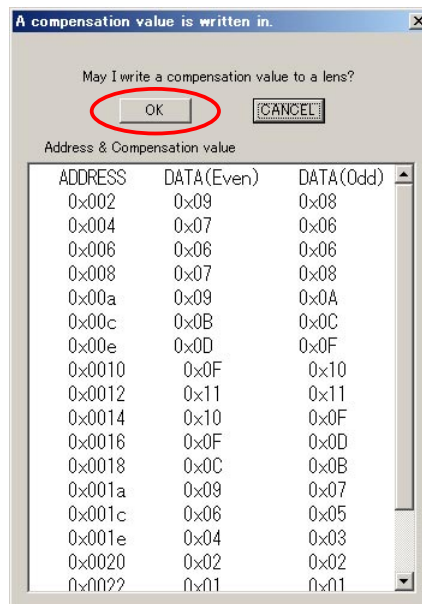

- ⑬ The reconfirmation screen is displayed. Click "OK".

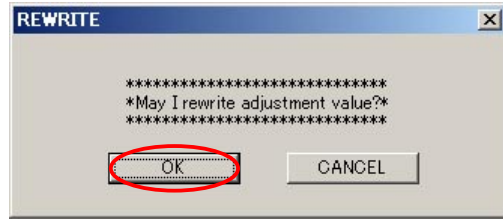

- ⑭ An hourglass is displayed on the screen, and writing starts.

The below screen is displayed after a few seconds. Turn camera OFF and turn it ON again.

Click "OK", and the adjustment software restarts.

Note: Unless the camera is turned off once, the value that was written in EEPROM is not reflected.

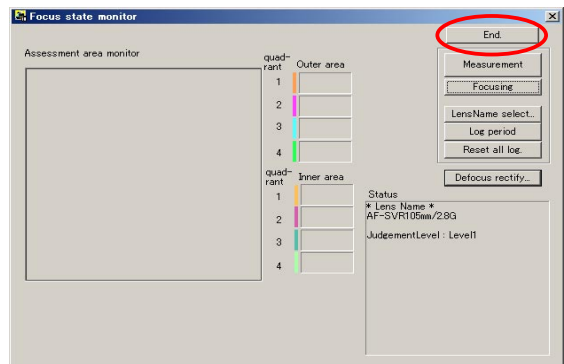
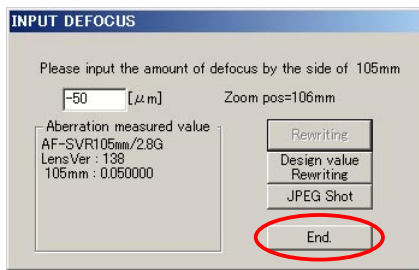

- ⑮ When the adjustment software restarts, perform the operations from ② to ⑩ again. Check that "0μm" of the AF position is in focus.

If "0μm" is not in focus, repeat the operations from ② to ⑮ .

If it is not still in focus even after repetition, the written value in EEPROM may be abnormal. So click "Design value Rewriting" to write the initial value, then proceed with the operations.

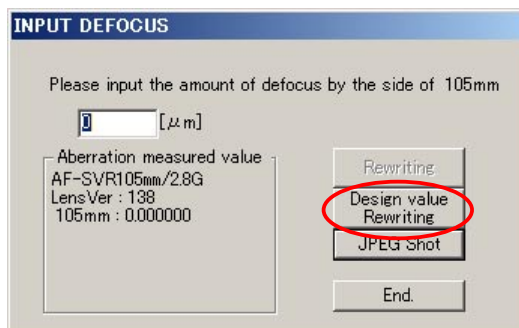

実体配線図 WIRING DIAGRAM

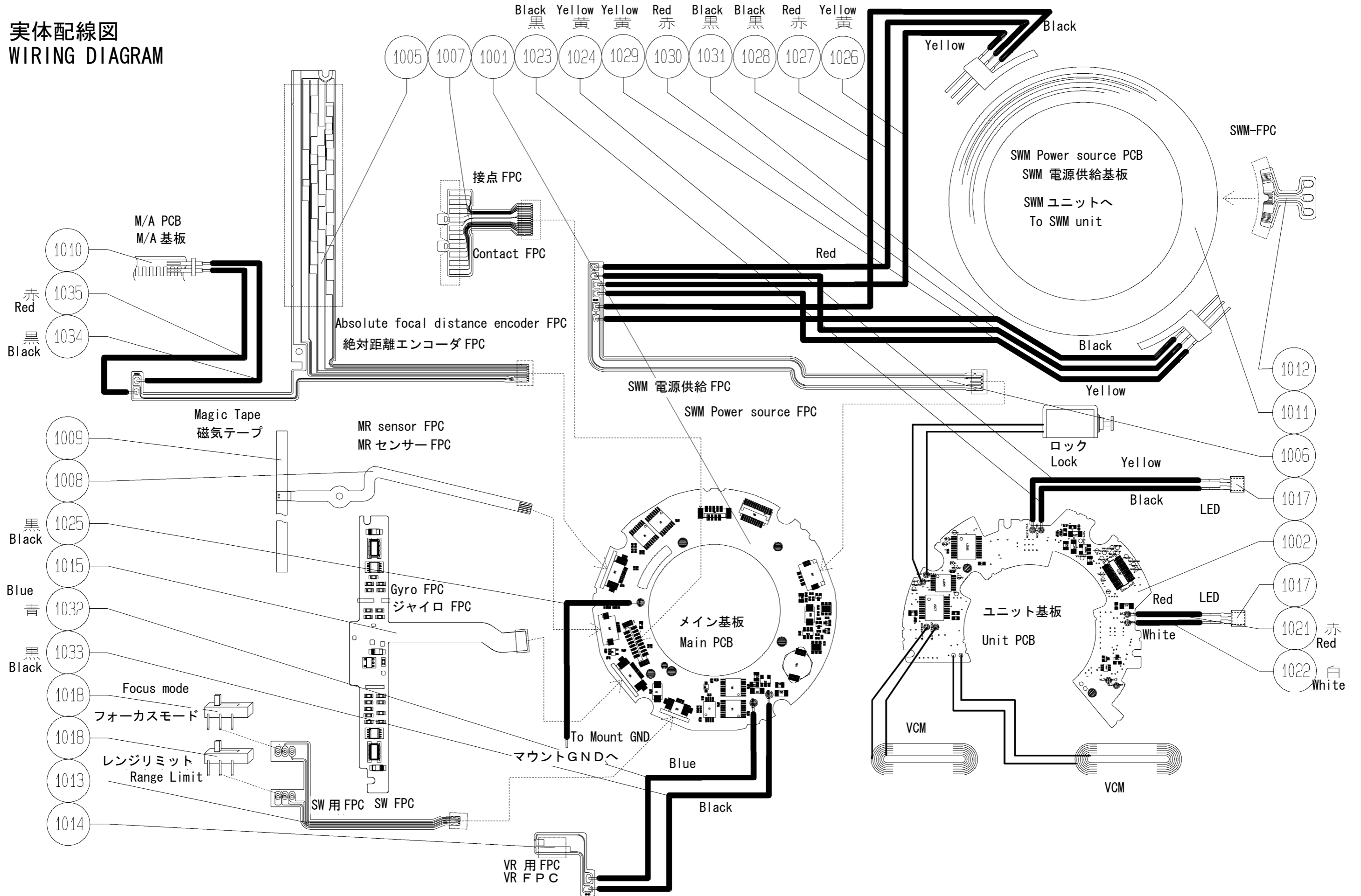

外觀圖 Sketch drawings

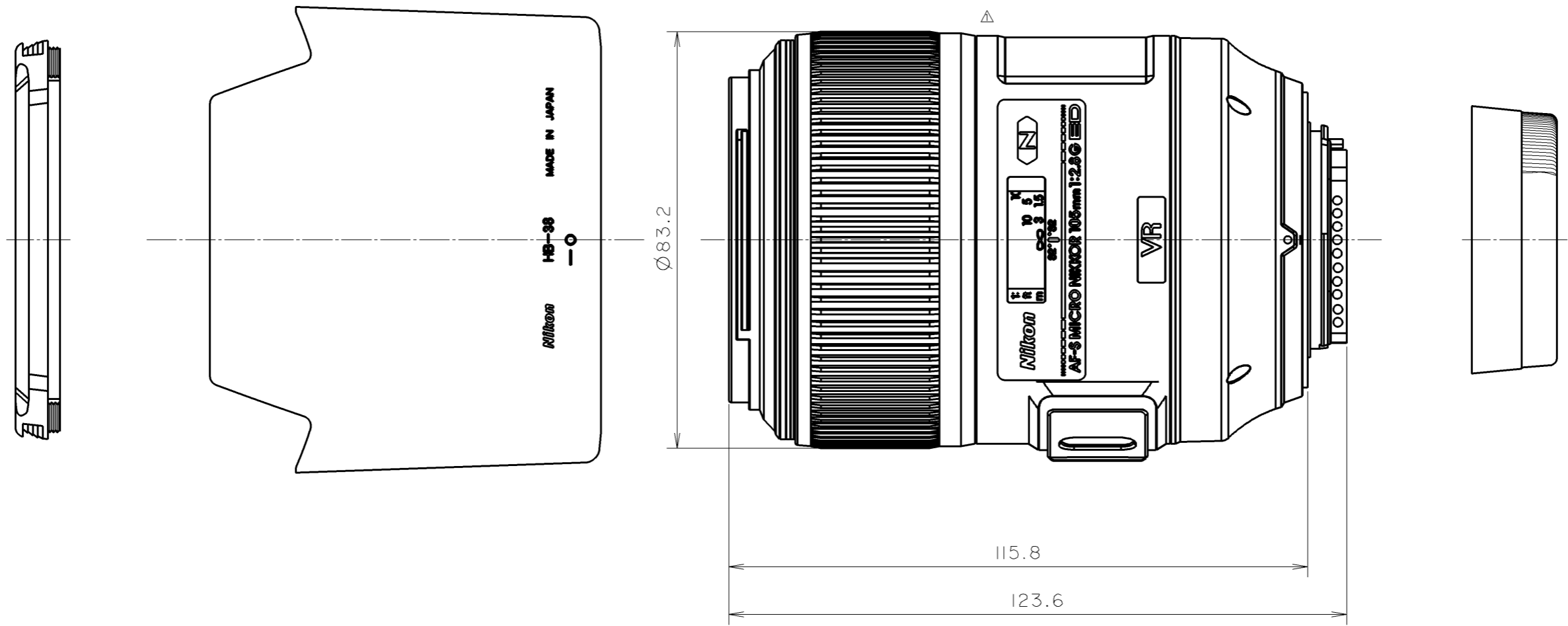

組立図 Structure of the Lens

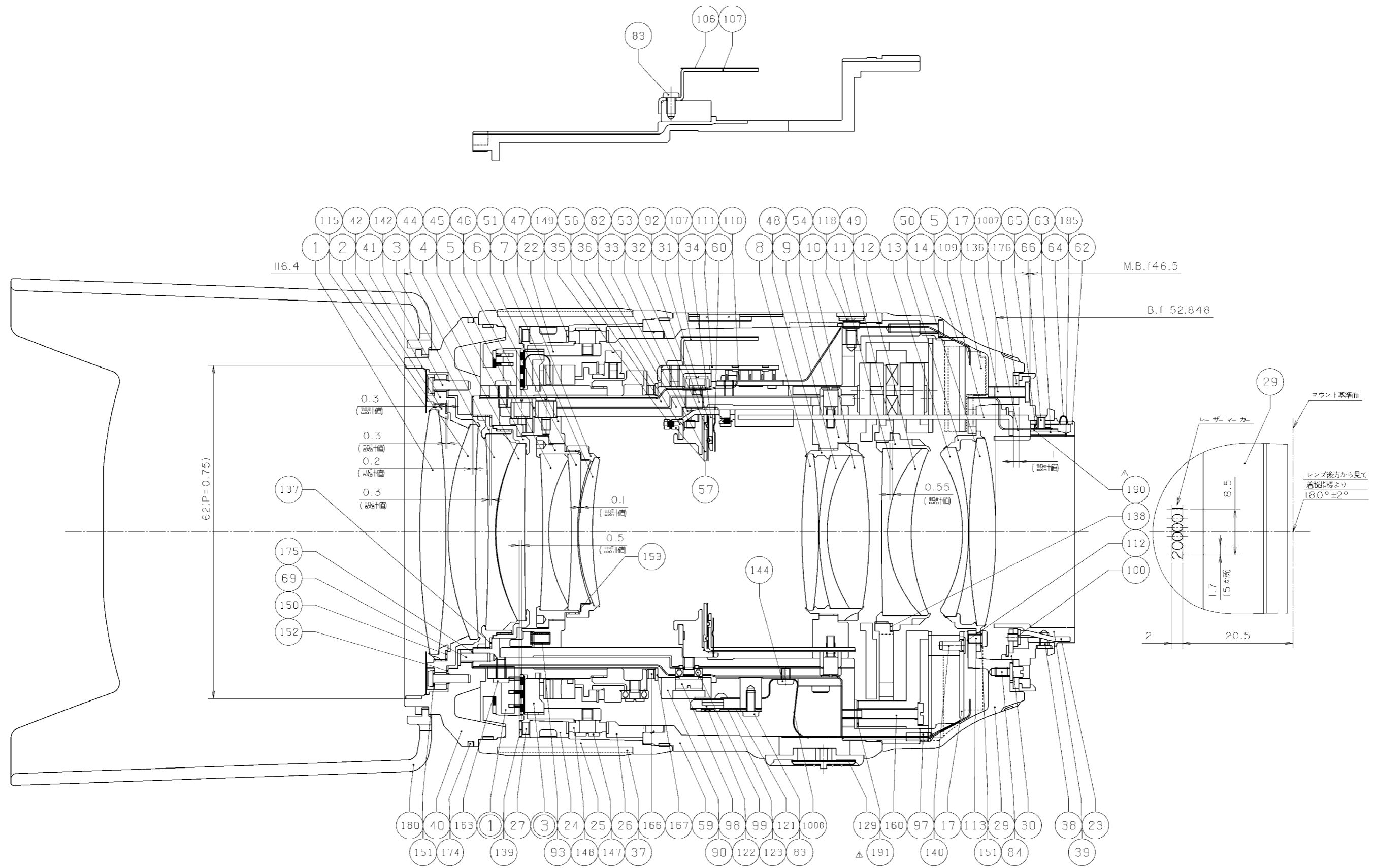

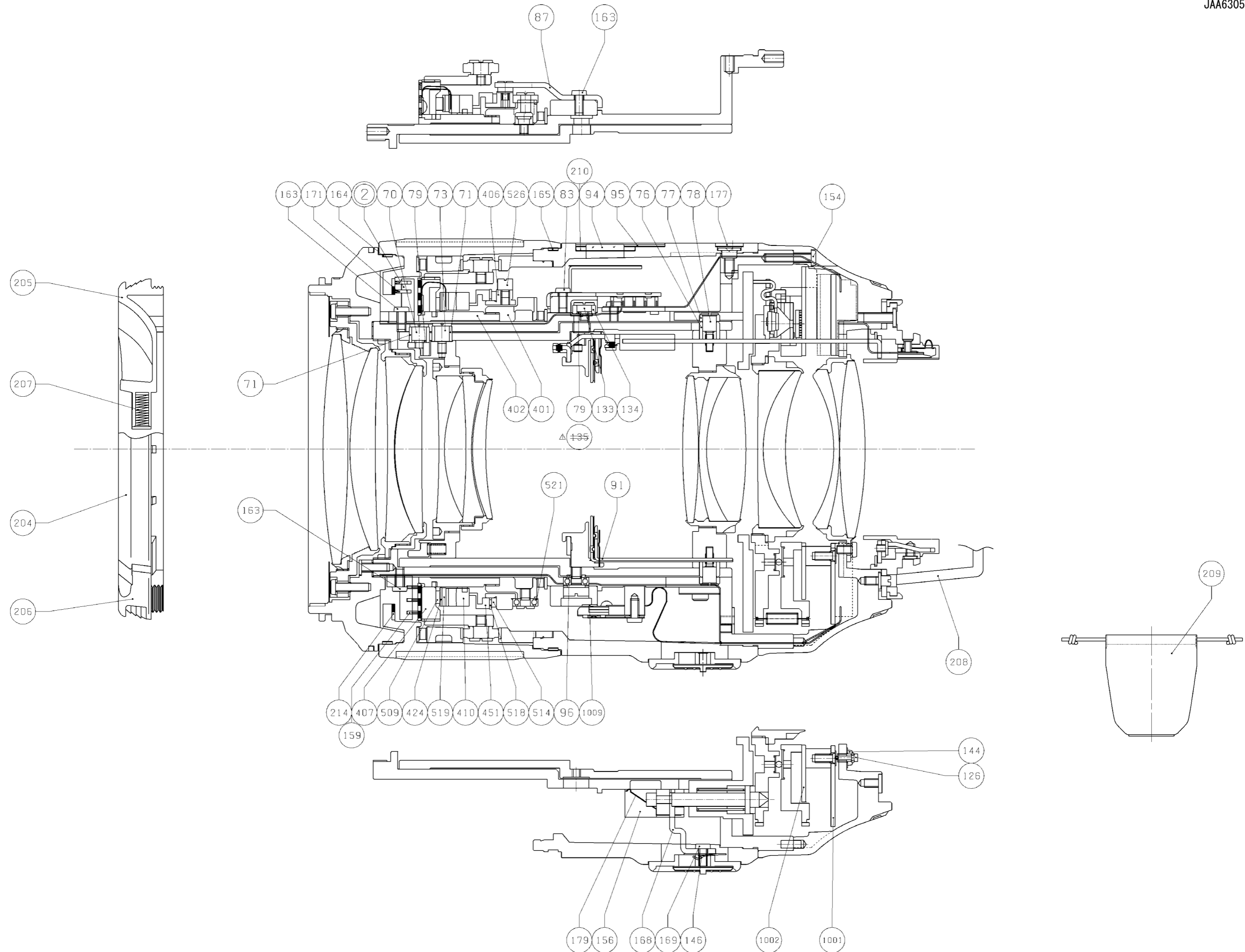

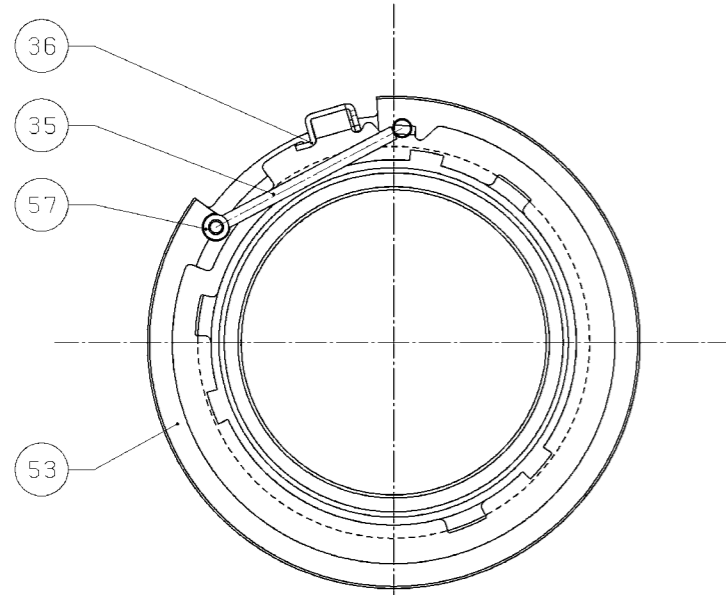

被写体側より見る

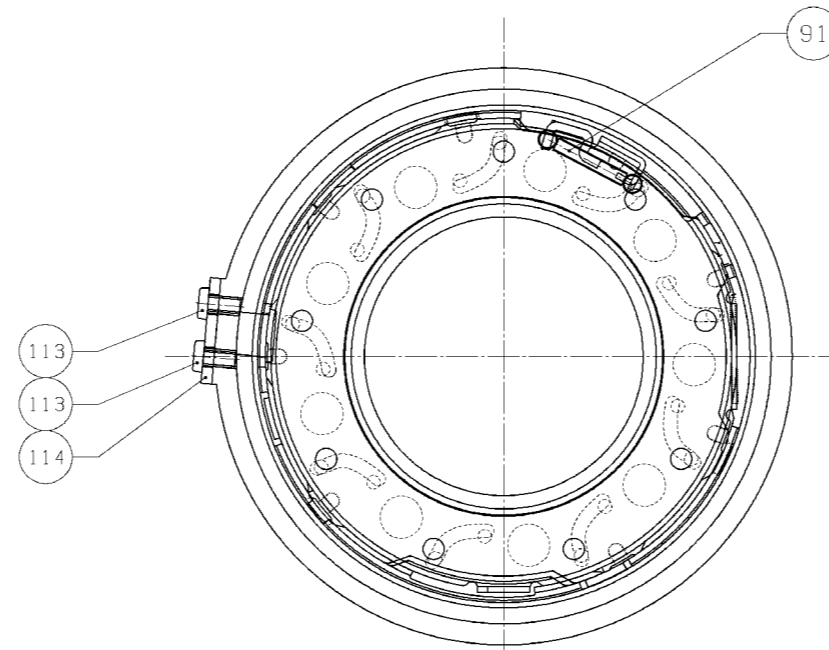

マウント後方より見る

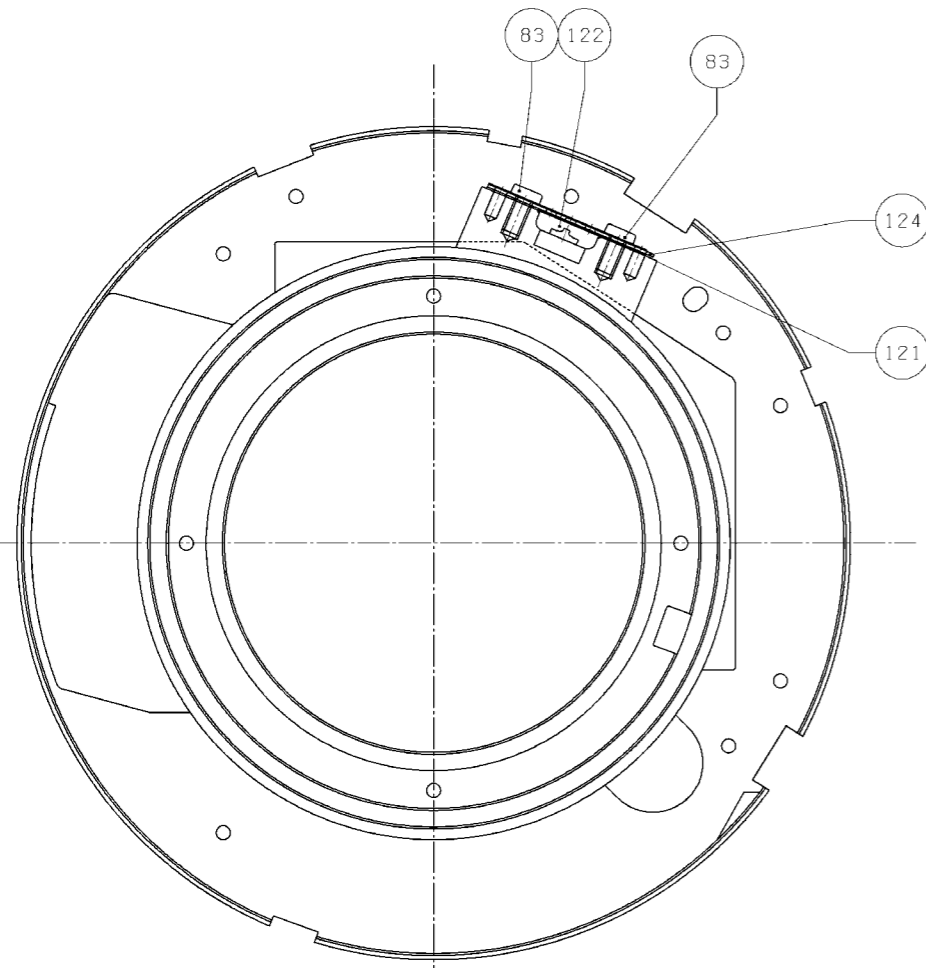
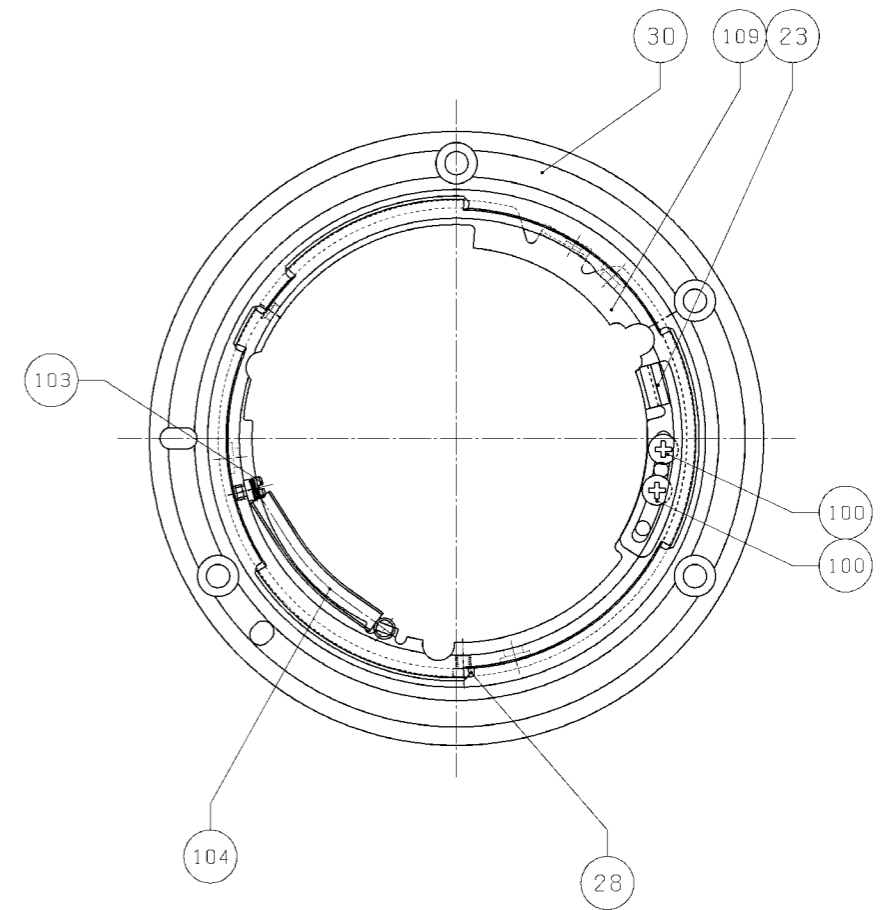

被写体側より見る

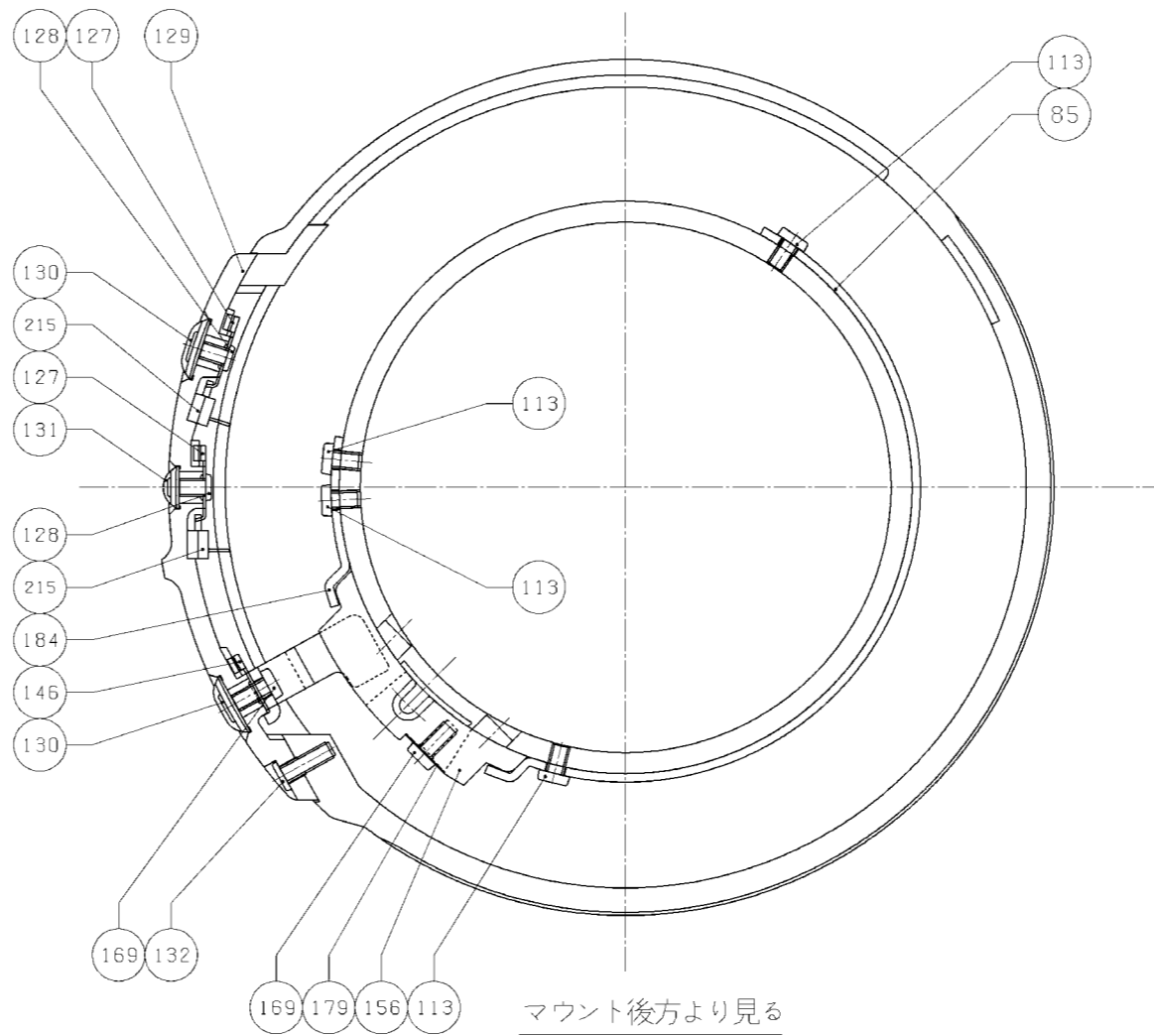

マウント後方より見る

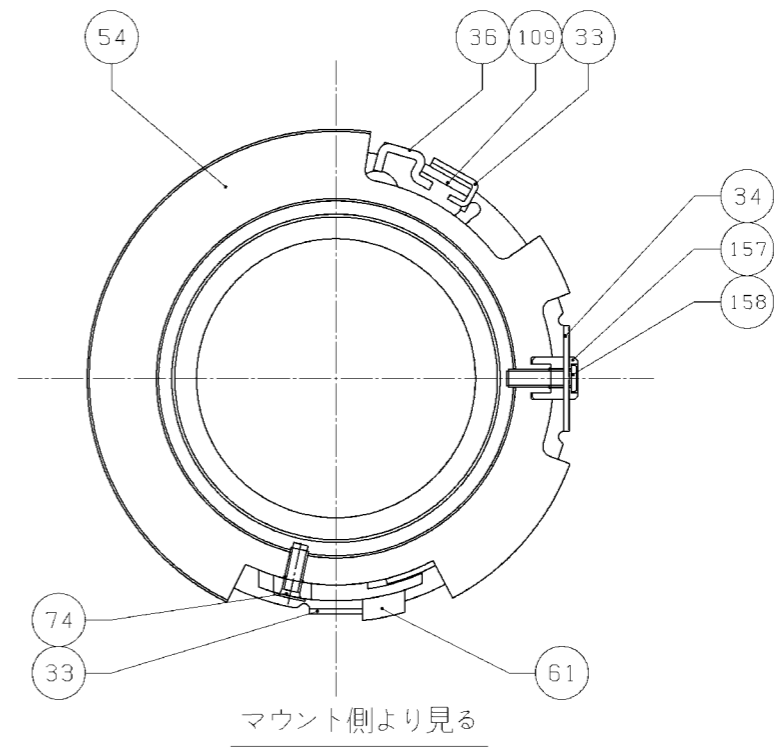
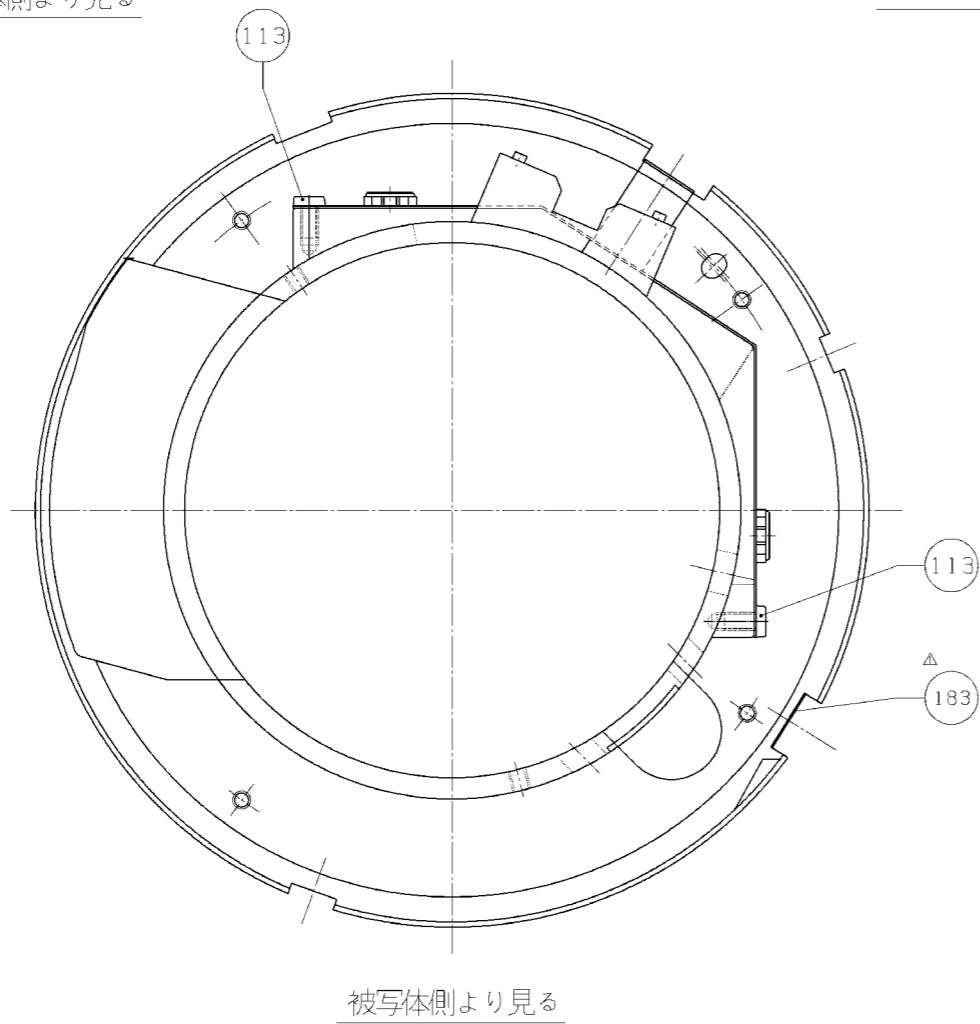
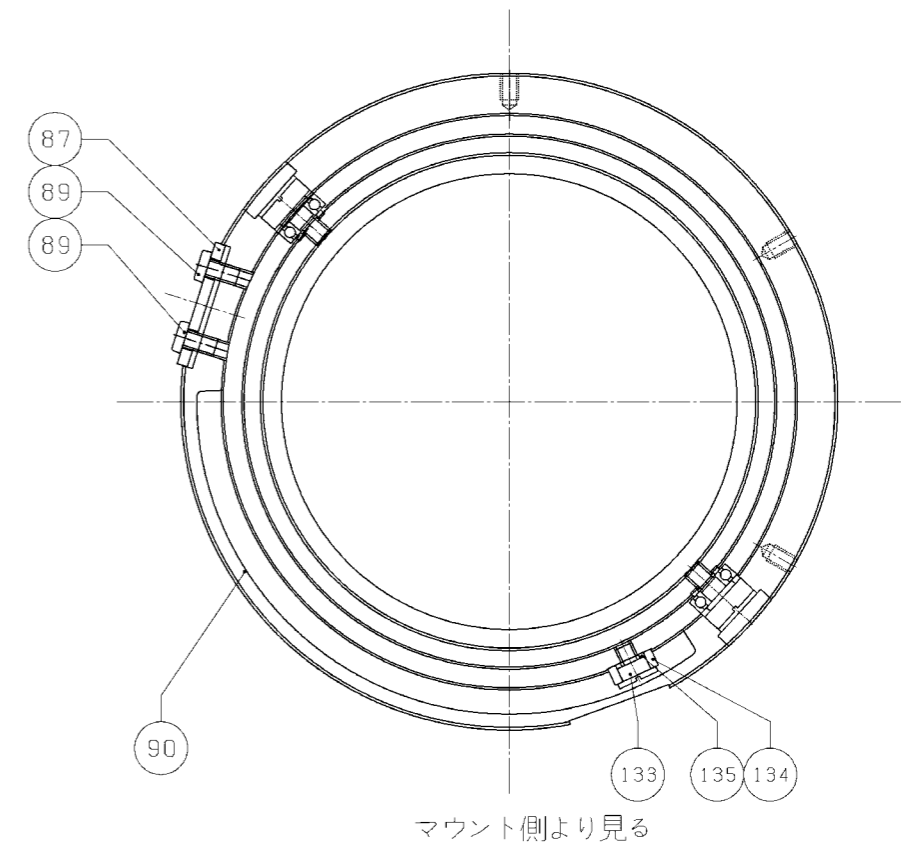
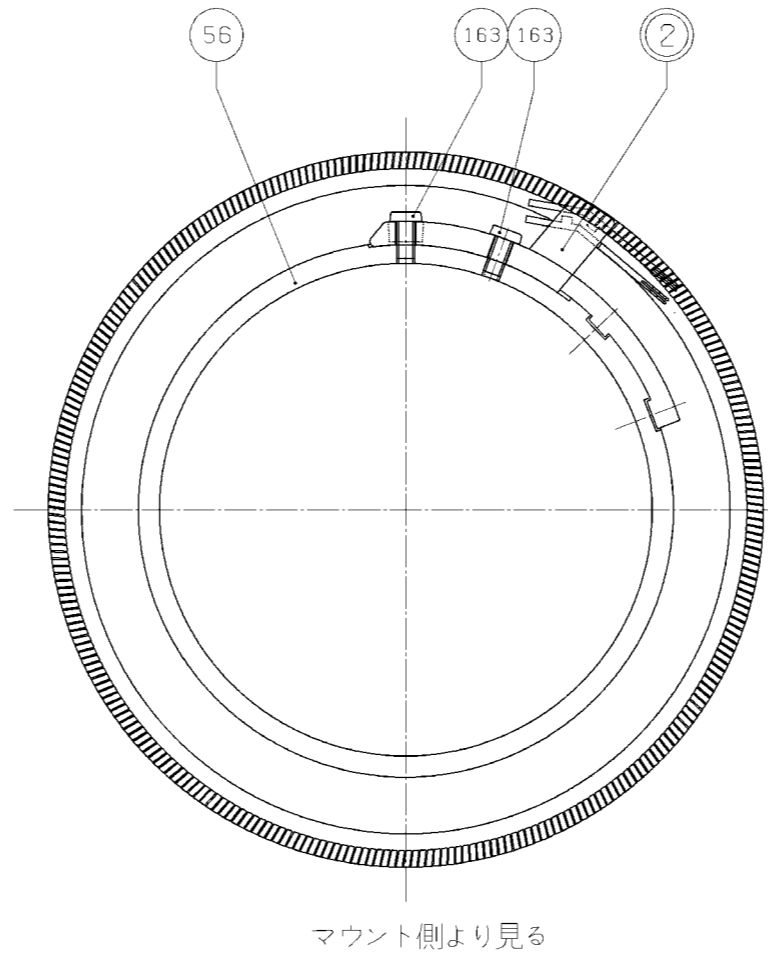
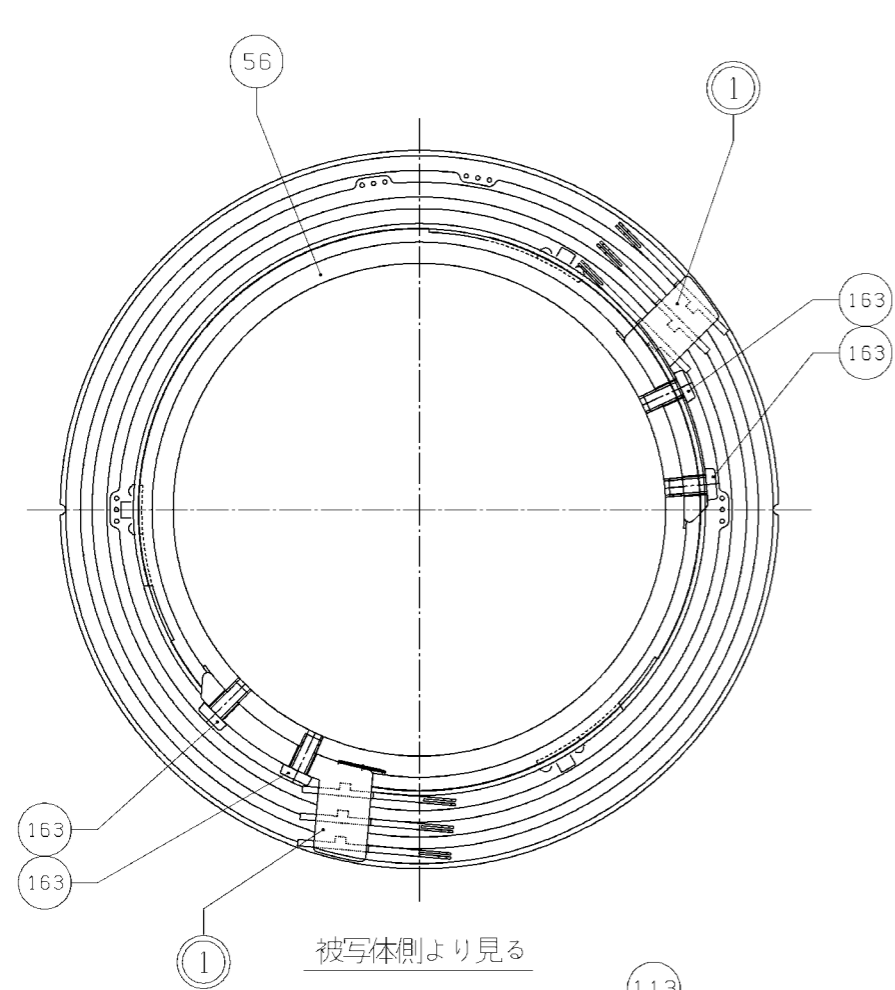

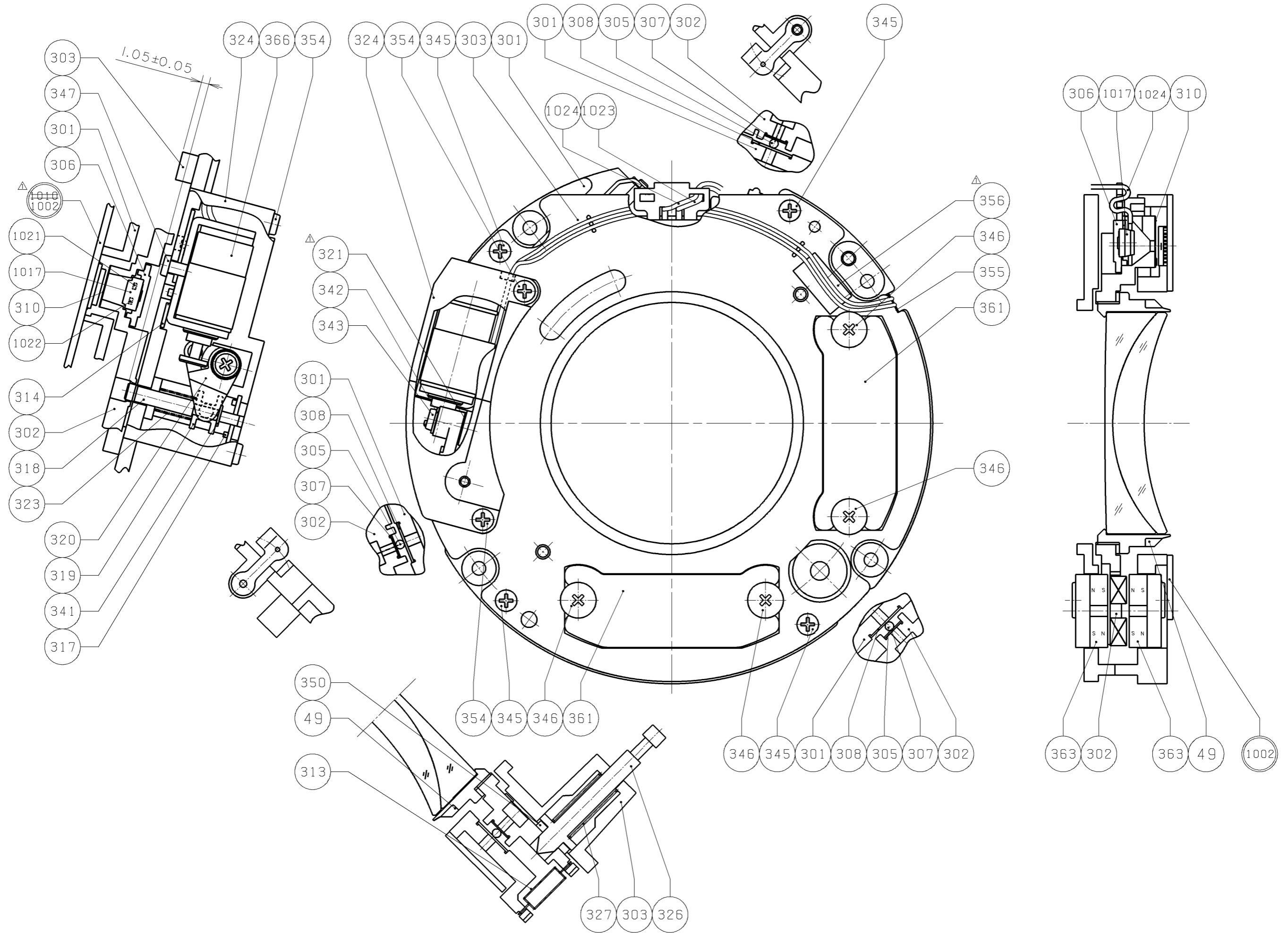

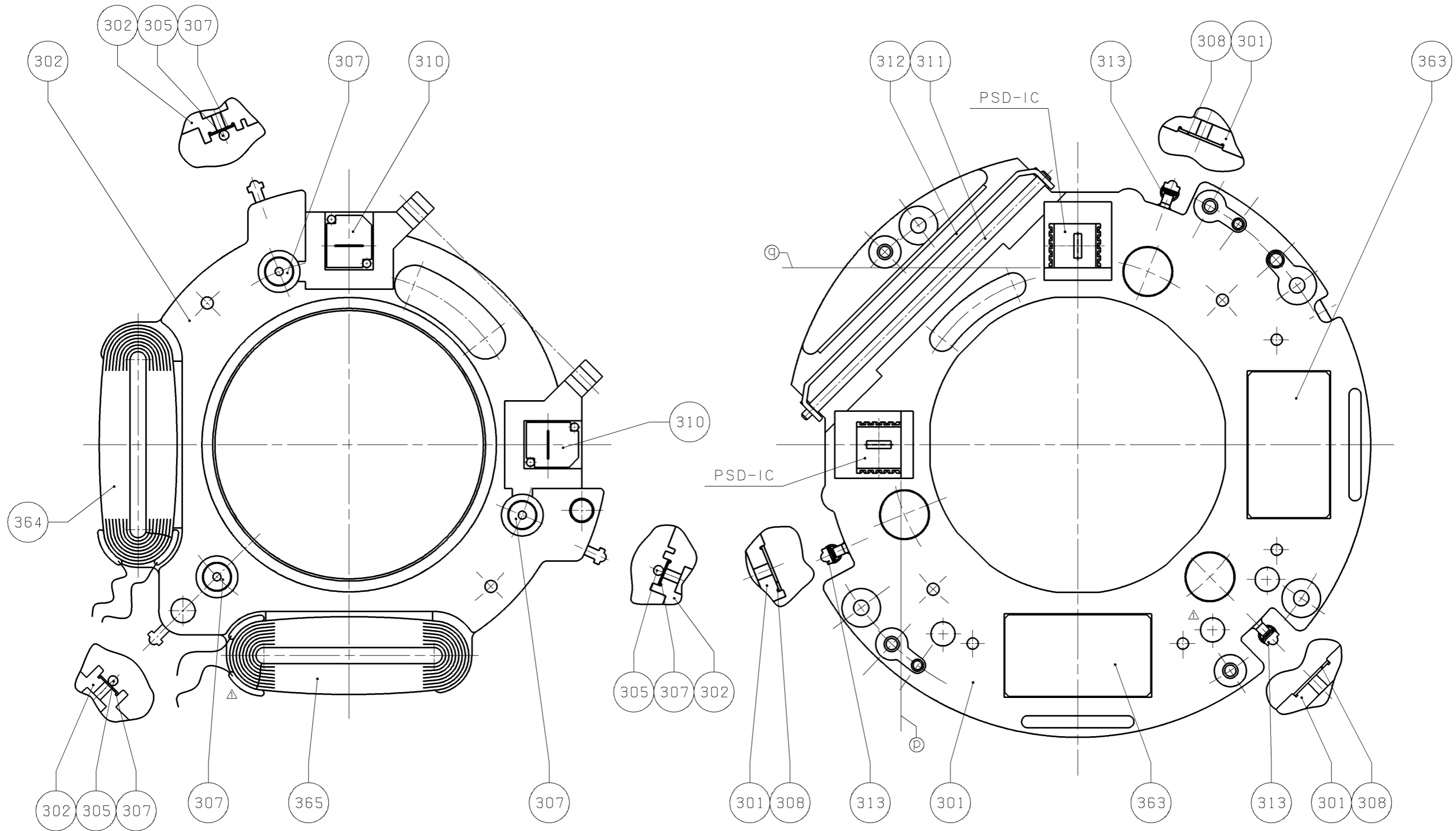

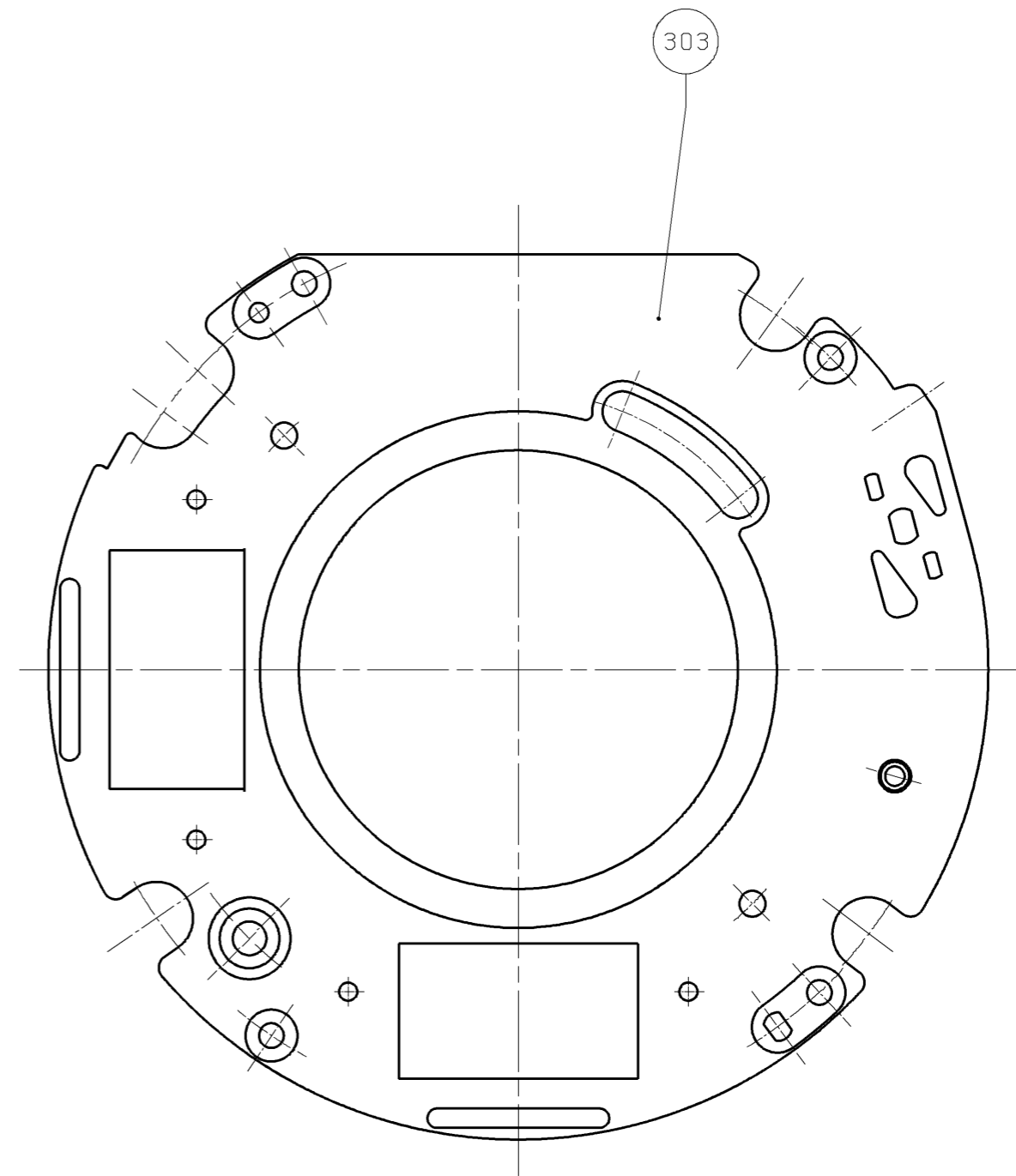
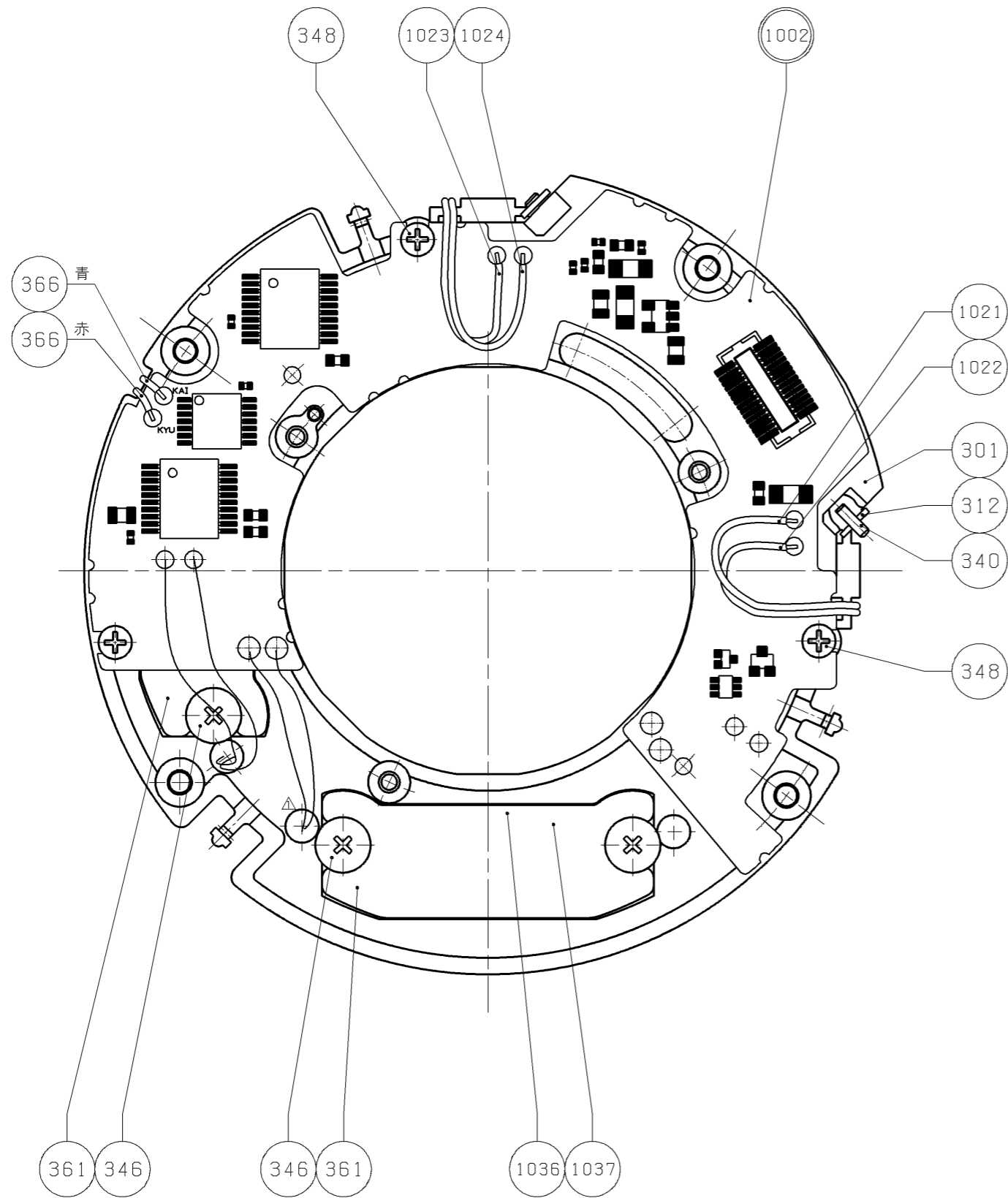





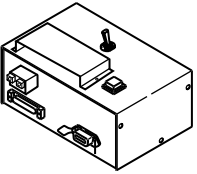





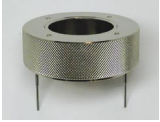

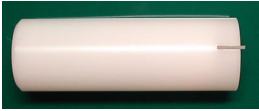
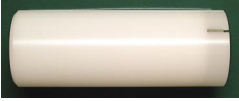
工具編 TOOLS

★ : NEW TOOL

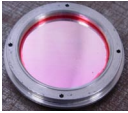
RJ 番号 RJ No.	名称 NAME OF TOOL	備考 OTHERS
J19002 	縦型焦点面検査器 LT-500S BACK FOCUS COLLIMATER LT-500S	
J9001-5N	安定化電源 5 A DC REGULATED POWER SUPPLY 5A	
J18028 	F 用レンズ受け台 LENS ADAPTER FOR FOCUS TESTER	
★ J18402 	AF-S VR105/2.8 調整用ソフト ADJ.FD FOR AF-S VR105/2.8 (IBM 3.5)	
J18004-1 	J 1 8 0 0 4 用基準ゲージ STANDARD GAUGE FOR J18004	
J15306-1 	A F - I 通信ボックス AF-I LENS COMMUNICATION BOX(CE)	
J15307 	A F - I 通信アダプター COMMUNICATION ADAPTER FOR AF-I	
自作工具 	自作工具 SELF-MADE TOOL	FOR AF-S18-200 VR
★ J11319 	AF-SVR105/2.8 無限位置出しピン INFINITY POSITIONING PIN	
★ J11329 	AF-SVR105/2.8 無限指標工具 INFINITY INDEX TOOL	
★ J18403 	VR 調整ソフト (AF-S 105/2.8VR) VR ADJ.FD FOR AF-S 105/2.8VR	
★ J18404 	AFS105/2.8 調芯装置用調整ソフト (LWM) ADJ.FD (LWM)FOR 105/2.8 ALIGNMENT	Ver.1.0

★ : NEW TOOL

RJ 番号 RJ No.	名称 NAME OF TOOL	備考 OTHERS
★ J11320 	1-2 群組込み工具 1-2rd LENS G ASSEMBLING TOOL	
★ J11321 	V R 固定工具 VR-FIXING TOOL	
★ J11322 	1-1 群組込み工具 1-1ST LENS G ASSEMBLING TOOL	
★ J11323 	3 群組込み工具 3rd LENS G ASSEMBLING TOOL	
★ J11324 	VR 群組込み工具 VR LENS G ASSEMBLING TOOL	
★ J11325 	5 群組込み工具 5th LENS G ASSEMBLING TOOL	
★ J11326 	Xタイプスリムピンセット X-TYPE SLIM TWEEZERS	
★ J11327 	1 群調芯工具 1ST LENS G ALIGNMENT TOOL	
★ J11328 	5 群調芯工具 5th LENS G ALIGNMENT TOOL	
★ J11330 	V R ミラ - 工具 VR MIRROR TOOL	
★ J11331 	ミラ - 取付け工具 VR MIRROR ASSEMBLING TOOL	
工具設定なし RJNo. is not available 	鉛フリーはんだコテ LEAD FREE SOLDERING IRON	
J5400 	鉛フリー糸はんだ RMA02(M705) 0.5MMX500G ECO SOLDER RMA02(M705) 0.5MMX500G	

RJ 番号 RJ No.	名称 NAME OF TOOL	備考 OTHERS
J19025 	ポイントテスター P T - 1 2 0 0 POINT TESTER PT-1200	廃番 discontinued
J15380-4 	オートコリメータ 6D(暗視野型) AUTO COLIMETER 6D FOR J15380	ニコンインストックより購入可能 Possible to buy from Nikon instech.
J19128 	調芯装置用チャート LENS ALIGNMENT CHART	
J19128A 	ライトビューワー (J19128 用) LIGHT VIEWER (J19128)	
J19129 	調芯装置用スライドレール LENZ ALIGNMENT EQUIP.SLIDE RAIL	
工具設定なし RJNo.is not available	オシロスコープ OSCILLOSCOP	
I-40	A F レンズ用グリース (I - 4 0) GREASE FOR AF LENS	
EDB0011	ネジ ロック (赤) 1401C SCREW LOCK 1401C	
G92KA	フロイル G 9 2 K A 2 0 G FLOIL (G92KA) 20G	
MZ-800S	ドライサーフ M Z - 8 0 0 S DRY SURF MZ-800S	
OS-30MF	ドライサーフ O S - 3 0 M F DRY SERF OS-30MF(OIL BARRIER)	
RR	ラバークリース RR RUBBER GREASE RR	
GE-8	A F レンズ 用 グ リ ース G E 8 GREASE FOR AF LENS GE-8 1KG	
EM-60L	モリコート 1Kg 缶 MORI COAT 1Kg can	

Making of Self-made Tool

- To inspect and adjust the output waveform of MR encoder, it is necessary to make a self-made tool by using the RP main PCB (IS020-426) of AF-SVR18-200. (If there is a defective main PCB after replacements/repairs, use the defective one.)

Make a self-made tool according to the following procedure.

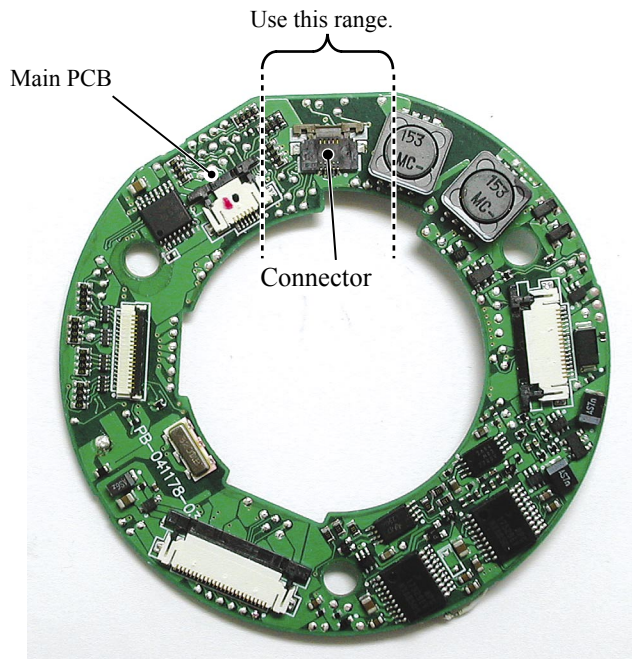

- ① Remove the mounted parts/elements (condenser, transistor, IC, etc.) from the both faces of the PCB within the range of the dotted lines. (See the left.) Do not remove the connector. (The parts/elements are not always needed to be removed, if they are not affected by the next cutoff or soldering.)

- ② Cut off the PCB along the dotted lines.

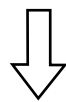

- ③ Solder the three wires on the pattern of the front-side PCB.

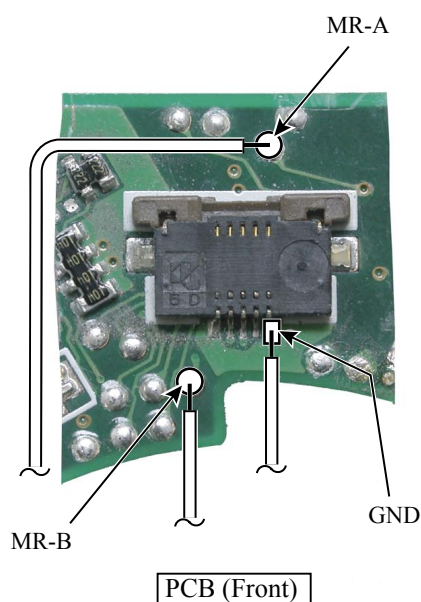

- ④ Solder the one wire on the pattern of the back-side PCB.

