

AF-I Nikkor ED 300mm f/2.8 D IF

REPAIR MANUAL

修 理 指 針

Nikon | NIKON CORPORATION
Tokyo, Japan

© Copyright 1988
ALL RIGHTS RESERVED
無断転載を禁ず!!

Supplement

◎ How to check F4 camera with AF-I lens

Note: This checking procedure is only for confirming if each of the following functions works properly. And for checking accuracy, please use the communication tool.

1. Autofocus operation

After subject was in focus, confirm the focus in the viewfinder.

It is normal that the lens stops one or two times until subject is correctly focused.

According to the conditions, there are occasions when lens scans subject. However, unless it focuses correctly, it is bad.

(Glass encoder or the contact of electrical circuit is bad.)

2. Range limiter (scan range is reference value)

Model	Full range	$\infty \sim$ middle	Middle \sim close
300/2.8	$\infty \sim 2.5\text{m}$	$\infty \sim 5.7\text{m}$	7.1m $\sim 2.5\text{m}$
600/4	$\infty \sim 6.0\text{m}$	$\infty \sim 11.3\text{m}$	14.3m $\sim 6.0\text{m}$

3. Focus lock switch

AF drive must be locked at all four spots and stop without fail even while it is scanning.

4. Mode select switch

① A mode

Even if you rotate the focus ring, you are ignored. At this time the focus ring can be rotated freely 360° .

② M/A mode

When you keep the shutter release button lightly pressed and rotate focus ring, the camera must be changed to M mode. At this time the focus ring rotates simultaneously with the distance scale. (In the case where they slips, the gearing of the clutch is bad.)

③ M mode

AF motor and clutch does not move. You can focus subject manually without fail.

5. ① In the situation where the whole lens is covered and ray is entered conversely only through the viewfinder, drive the AF lens. At this time it moves at a low and even speed.

- ② Attaching SB-24 or MF-23 with it, confirm that the indicator of the maximum aperture on lens is F4 or F2.8. And P and S mode on F4 body must operate normally. (Unless they operate, the point of contact in camera or lens is bad, or electrical system in lens is bad.)

Supplement

© CHECKING PROCEDURE OF TC-14E AND TC-20E

1. Attach the AF-I lens (300/2.8, 600/4) to the Teleconverter (TC-14E, TC-20E) .
2. Mount them on the F90 camera.
3. Set the AE mode of the camera to M position, and set the lens at the maximum aperture.
4. Confirm the display of the F value on the camera.

Combination	Display
AF-I 300/2.8 + TC-14E	F4
AF-I 300/2.8 + TC-20E	F5.6
AF-I 600/4 + TC-14E	F5.6
AF-I 600/4 + TC-20E	F8

5. Set the camera at AF mode, then check the AF function.
6. With a Teleconverter independently, check the continuity between camera side and lens side of each E and H contact.
These contacts are two of those lined counterclockwise (seen from the camera mounting side) in alphabetical order.

Standard : Less than 5 Ω (Both E and H contacts)

目 次

[1]	仕様編	-----	M 1
[2]	分解編	-----	D 1
[3]	組立・調整編	-----	A 1
[4]	電気編		
	実体配線図	-----	E 1
	回路図	-----	E 2
	メインFPC	-----	E 3
	LED FPC	-----	E 4
	ICピン配置表	-----	E 5
[5]	検査規格・工具編	-----	T 1
[6]	部品表編		
	記号説明	-----	K 1
	テープ類TA設定部品一覧表	-----	K 3
	リードワイヤー一覧表	-----	K 4
	収縮チューブ一覧表	-----	K 5
	展開図 (Fig. 1~Fig. 3)	-----	P 1
	部品表	-----	P 4
	部品対照表	-----	P 2 3
	組立図	-----	P 2 7
	接着給油図	-----	P 3 1

C O N T E N T S

[1] Specifications -----	M 1
[2] Disassembling -----	D 1
[3] Assembling/Adjustment Procedure ---	A 1
[4] Electric Circuit	
Wiring Diagram -----	E 1
Circuit Diagram -----	E 2
Main FPC -----	E 3
LED FPC -----	E 4
IC Terminal -----	E 6
[5] Inspection Standard, Tool -----	T 1
[6] Parts List	
MARKS IN THE PARTS LIST -----	K 1
TAPES AND FILMS WITH PREFIX ALPHABETS TA -----	K 3
LEAD WIRE LIST -----	K 4
THERMAL CONSTRUCTION TUBE LIST -----	K 5
Exploded Drawings -----	P 1
Parts List -----	P 4
Parts Number Reference Table -----	P 2 3
Construction of the Lens -----	P 2 7
Lubricant and Binding Agent Chart -----	P 3 1

AF-I Nikkor ED 300mm f/2.8 D IF

JAA32651-R. 3311. A

1. Specifications

1-1. Function

AF:Auto focus MF:Manual focus FA: Focus aid

Lens		Lens focus mode		
Camera	Mode	M (MF)	M/A (MF OR AF)	A (AF)
F4	C	FA operation is performed manually while pressing the shutter release button slightly. * Shutter prerelease time is prolonged while operating the focusing ring.	<ul style="list-style-type: none"> AF operation is activated when the shutter release button is pressed lightly pressing. Press the shutter release button slightly and operate the focusing ring to change the focus mode from AF to MF, and turn the shutter prerelease timer OFF to change the focus mode from MF to AF. Press the shutter release button slightly and operate the focusing ring to change the focus mode from AF to MF. 	AF operation is activated when the shutter release button is lightly pressing.
	S			
	M			
Other camera	C	FA operation is performed manually while pressing the shutter release button slightly.	AF and MF No operation	AF and MF NO operation
	S			
	M			
NON AF camera		AF NO operation	-ditto-	-ditto-

1-2. CPU contact

Contact	Contacts	Contact	Contacts
A	VCC	G	Motor GND
B	R/W1	H	Hotline, Pulse
C	Clock	I	Reserve
D	DATA	J	Reserve
E	Hotline, Pulse	Mount	GND
F	Power source for motor		

* Contacts are marked from "A" to "J" as viewed counter-clockwise from the rear of the lens (from the mount side).

2. AF-I lens inspection and adjustment system

2-1 Outline

This system consists of AF-I lens inspection and adjustment software (J18231), AF-I lens communication adapter (J15307), AF-I communication box (J15306), personal computer, oscilloscope and DC-regulated power supply.

With this system, when making inspection and adjustment of an AF-I lens, you can monitor lens operation and condition and get a numerical readout on the computer screen by simulating the same conditions as when the AF-I lens is mounted on the actual camera body.

As a result, it is possible to check AF-I lens accuracy in various respects and to decide whether or not the lens is in good condition or is defective. Troubleshooting for the AF-I lens is now simpler and more effective.

System diagram

With DC-DC converter, one unit of DC regulated power supply can provide the system with enough power. The figure shows an example which uses DC-DC converter for F4 cameras. We will discuss on this matter in the following pages provided that we have modified as shown here.

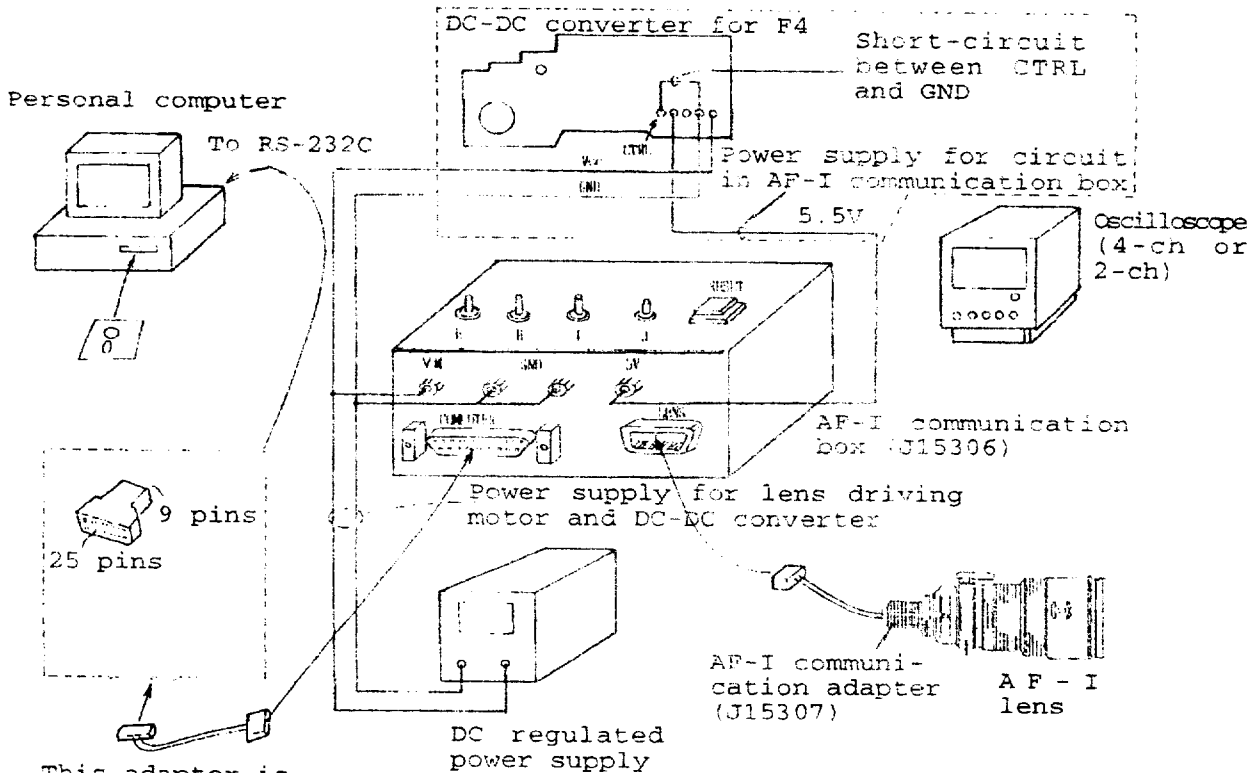

This adapter is necessary for a computer with 9-pin RS-232C terminal. RJ is not available.



2-2 AF-I inspection and adjustment program

(1) Menu screen

Nikon AF-I Lens Inspection & adjustment program.

1. Inspection of switches & lens condition.
2. Inspection of lens driving stop accuracy.
3. Inspection of lens servo time.
4. Inspection of play of lens driving gears.
5. Inspection of hot line signal out put.
6. Inspection of clutch motor operation.
7. Inspection of lens driving operation (1).
8. Inspection of lens driving operation (2).
9. Return on the SYSTEM.

Please select appropriate item by UP,DOWN,<-,>,key

(or hit number) and hit RETURN key.

1) For PC-9801 clone.

2) Communicate by RS232C terminal.

3) Revised edition 1993-11-25. (C) Copyright Nikon CORP.

- 1) Indicating the type of personal computers which can be used.
- 2) Indicating the interface with personal computers.
- 3) Indicating the software version number (revised date)



(2) Entering lens communication mode screen

[Entering lens communication mode.]

- 1) * Set the lens drive mode selector on 'A' or 'M/A'.
- 2) * Set lens comm. adpt. and turn on the power.
- 3) * Hit RETURN key, after RESET the AF-I lens communication tool.

* Return to the menu, when hit SPACE key.

- 1) Prompt to set the AF-I lens drive mode selector.
- 2) Prompt to set the AF-I lens inspection and adjustment system (using oscilloscope when necessary) and to supply power from DC regulated power supply to the AF-I lens communication box. Supply voltage is normally set to 6.0V. The computer screen may prompt you to set the voltage to 6V as shown in the screen on next page.
- 3) Prompt to hit RETURN key after pressing the RESET key on the AF-I lens communication box.

4) * Set 6.00(U) for lens driving motor.

5) * Place the lens to horizontal direction.

Hit RETURN key.

4) Prompt to set the supply voltage from the DC-regulated power supply to the AF-I lens communication box.

5) Prompt to position the lens.

Do not position the lens vertically as the helicoid will not move uniformly from close to infinity and infinity to close and, as a result, correct inspection becomes impossible.

(3) Inspection of switch and lens condition

```

1) Type of lens : AF-I NIKKOR 300mm/2.8D      2) CPU version : 2.18
Inspection of switches & lens condition.
3) Focusing encodor      :      (Pin) 35 36 37 38 39 40 41 42 43 44
                               L  L  H  H  H  H  H  H  H  H
4) Focus mode selector   : M/A                Pin 50: H   Pin 51: H
5) Clutch switch        : M side             Pin 46: L   Pin 47: H
6) Focus lock switch    : Off                Pin 52: H
7) Focusing range limiter switch : Full      Pin 48: H   Pin 49: L
8) Helicoid position    : Infinity
9) M mode interruption in M/A mode: Interrupting ! Pulse count = 10
-----
Return to the menu, when hit any key.
    
```

- 1) Indicating the type of lens
- 2) Indicating the built-in CPU version number
- 3) You can monitor the change of distance encoder signals when turning the manual focus ring while setting the lens drive mode selector to M or M/A mode.
- 4) Monitoring the setting of the lens drive mode selector is possible.

Setting of lens drive mode selector	Signal	
	Pin 50	Pin 51
M	H	L
M/A	H	H
A	L	H



5) Monitoring the setting of clutch switch is possible.

Setting of lens drive mode selector	Setting of clutch switch	Signal	
		Pin 46	Pin 47
M	M side switch is ON.	L	H
M/A	Normally A side switch is ON.	H	L
	M side switch is ON when executing manual interruption.	L	H
A	A side switch is ON.	H	L

6) Monitoring the setting of focus lock switch is possible.

Setting of focus lock switch	Signal
	Pin 52
Focus lock switch is OFF.	H
Focus lock switch is ON.	L

7) Monitoring the setting of focus range limiter switch is possible.

Setting of focus range limited switch	Signal	
	Pin 48	Pin 49
Full	H	L
Infinity to Intermediate	L	H
Intermediate to close	H	H

8) Indicating the position of helicoid (close, intermediate, infinity) based on the distance encoder signal.

9) When the lens drive mode selector is set to M/A mode, a pulse (M mode interruption recognition pulse) is output from the manual focus encoder when turning the manual focus ring. When the built-in CPU recognizes more than 2 pulses during a constant period, the lens drive mode is switched from auto focus to manual focus. We call this operation "interruption". This screen shows the number of pulses when interruption is executed in M mode.



(4) Inspection of lens driving stop accuracy

```

Type of lens : AF-I NIKKOR 300mm/2.8D          CPU version : 2.18

Inspection of lens driving stop accuracy.

1) Number of lens go-and-return operations.      : 10 / 10 time(s).
2) Number of lens lens driving times.            : 205 time(s).
3) Maximum pulse number. (absolute value)        : 7 pulse(s).
4) Ratio of occurrence of pulse 7 or more.       : 0.98 %.
5) Over ( or under ) run pulse(s).              : 0 pulse(s).

6) Direction.      : Inf->Close   Inf->Close   Close->Inf   Close->Inf
   Amount          : Df0,Df2,Df3   Df1         Df0,Df2,Df3 Df1
   Under (-),Over (+):  (-)  (+)  (-)  (+)      (-)  (+)  (-)  (+)
   Range (pulse(s)) :
   0 - 6           : 23   46   23   12         23   43   21   12
7) 7 - 14         : 0    1    0    0         0    1    0    0
   15 - 20        : 0    0    0    0         0    0    0    0
   21 -           : 0    0    0    0         0    0    0    0

Return to the menu, when hit RETURN key.
    
```

Outline

Measure the lens driving stop accuracy against the specified stop position and evaluate the lens driving stop accuracy by counting the number of overrun or underrun pulses. Be sure to set the voltage for lens driving motor to 6.5V.

- 1) Indicating the number of lens go-and-return operations.
- 2) Indicating the number of lens driving times.
- 3) Indicating the absolute value of the maximum numbers of overrun or underrun pulses against the specified stop position.
- 4) Indicating the ratio of occurrence of pulse 7 or more against the specified stop pulses.

$[(\text{Number of occurrence of pulse 7 or more}) / \text{Number of lens driving times}] \times 100 = \text{Ratio of occurrence of pulse 7 or more (\%)}$.



- 5) Indicating the number of overrun or underrun pulses against the specified stop pulses.
- 6) Amount of lens servo and driving patterns

Type	Amount of lens servo
Df0	Varies in every go-and-return operation
Df1	Fine driving
Df2	Large driving
Df3	Small driving

Driving patterns

Infinity -> Df0 -> Df1 -> Df2
Repeat this operation up to the close end

Close -> Df0 -> Df3 -> Df1 -> Df2
Repeat this operation up to the infinity end

Repeat the above operations 10 times to measure the whole range of the helicoid.

- 7) Indicating the number of occurrence of overrun (or underrun) pulses for every occurrence range in the direction of lens servo at every amount (Df0, Df1, Df2, Df3).

Standard

- 1) The ratio of occurrence of pulse 7 or more is acceptable up to less than 10%. (Refer to the values on the screen 4.)
- 2) In the pulse occurrence range of 15-20, one time pulse occurrence is acceptable. (Refer to the values on the screen 7.)
- 3) In the pulse occurrence range of 21 or more, it is not acceptable if pulse occurs even once. (Refer to the values on the screen 7.)

All values in the items 1) to 3) above should be within the range of standard values.



(5) Inspection of lens servo time

```

Type of lens : AF-I NIKKOR 300mm/2.8D          CPU version : 2.18

Inspection of lens servo time.

1) Number of lens go-and-return operations.      :      5 / 5 time(s).
2) Number of lens driving operation.              :      61 time(s).
3) Ratio of driving time against the minimum driving time.:      1.00
4) Maximum ratio of driving time.                 :      1.31
5) Constant value ( more than 1.91 ) of time ratio. :      0 %

Direction of lens servo. :   Inf -> Close          Close -> Inf
6) Amount of lens servo.  :           6 mm              6 mm

      0 - 1.00 :      4 time(s)          5 time(s)
      1.01 - 1.90 :     27 time(s)       25 time(s)
7) 1.91 - 2.60 :      0 time(s)         0 time(s)
      2.61 - 3.60 :      0 time(s)         0 time(s)
      3.61 -      :      0 time(s)         0 time(s)

Return to the menu, when hit RETURN key.
    
```

Outline

Measure the time taken at a constant driving amount (Df12) and check to see if there is something abnormal in the servo driving. Be sure to set the voltage for the lens driving motor to 5.5V. The results will be displayed after repeating lens go-and-return operations five times.

- 1) Indicating the number of lens go-and-return operations.
- 2) Indicating the number of lens driving times.
- 3) Ratio of driving time for each measurement against the maximum time taken at driving amount Df12. The minimum driving time is set to 1.
- 4) Ratio of the maximum driving time until the next measurement against the minimum driving time taken at driving amount Df12.
- 5) Driving ratio is a driving time ratio against the minimum mean time* at driving amount Df12. Here shows the ratio of occurrence of pulse with the driving ratio of more than 1.91.

*Mean value of 10 sampling data taken out of minimum driving times from smaller to larger ones.



- 6) Amount of lens servo and driving patterns
 • Servo driving amount

Type	Amount of lens servo
Df0	Varies in every go-and-return operation
Df12	Medium driving

Note: Df10 is not displayed on the screen as it is not yet measured.

• Driving patterns

Infinity → Df10 → Df12 → Df12 → Close
 Close → Df10 → Df12 → Df12 → Infinity
 Repeat the above procedures five times covering the whole range of helicoid.

- 7) Indicating the number of occurrence of pulse for every driving ratio range at every amount Df12 in every direction of lens servo.

Standard

- 1) In the driving ratio range of under 1.90, any number of occurrence of pulse is acceptable. (Refer to the values on the screen 7.)
- 2) In the driving ratio range of over 1.90, less than 10% of occurrence of pulse is acceptable. (Refer to the values on the screen 5.)
- 2) In the driving ratio range of 2.61 to 3.60, only one occurrence of pulse is acceptable. (Refer to the values on the screen 7.)
- 4) In the driving ratio range of over 3.61, it is not acceptable if pulse occurs even once. (Refer to the values on the screen 7.)

All values in the items 1) to 4) above should be within the range of standard values.



(6) Inspection of play of lens driving gears

Type of lens : AF-I NIKKOR 300mm/2.8D CPU version : 2.18

Inspection of play of lens driving gears.

Hot line signal is out put from terminal 'E'.

Hit SPACE key and mesure play of lens driving gear.

Return to the menu, when hit RETURN key.

Outline

Delay time from the starting of rotation of AF motor (for driving lens) until the output of the hotline signal due to the play of lens driving gears. If this delay time becomes larger, AF accuracy is affected. Therefore it is necessary to check and confirm the amount of play by counting the output of AF motor pulse inspection PI pulses.

Count the output of the AF motor pulse inspection PI pulses from the starting of rotation of AF motor until the output of the hotline signal.

Standard
Within 10 pulses

(7) Inspection of hot line signal output

Type of lens : AF-I NIKKOR 300mm/2.8D	CPU version : 2.18
Inspection of hot line signal out put.	
1) 1. No hot line signal is out put.	
2) 2. Hot line signal is out put from terminal 'E'.	
3) 3. Hot line signal is out put from terminal 'H'.	
4) 4. Hot line signal is out put from terminal 'E' and 'H'.	<<----- *
5. Direction of lens drive is ----->	[Inf ----> Close]

Change the each item setting while lens driving motor stops.

Hit SPACE key to rotate focusing motor.

Return to the menu, when hit RETURN key.

In this inspection system, we designate two rectangular wave forms converted from four sinusoidal wave forms output from glass encoder as a hotline signal. We will output two wave forms (phase A and B as they are) or exclusive OR signal from the E and H terminals of the AF-I lens communication box through built-in circuitry. You can check the state of lens operation and hotline output by monitoring the wave forms using an oscilloscope.

- 1) No hotline signal is output from the lens contacts (E and H) when entering 1 from the keyboard.
- 2) Exclusive OR (phase A and B) signal is output from the terminal E or H when entering 2 or 3 from the keyboard.
- 3) Signal is output from the lens contact E (phase B) and terminal H (phase A) when entering 4 from the keyboard.
- 4) Lens driving direction can be selected when entering 5 from the keyboard.



(8) Inspection of clutch motor operation

Type of lens : AF-I NIKKOR 300mm/2.8D

CPU version : 2.18

Inspection of clutch motor operation.

Clutch switch

: A side

Pin 46: H

Pin 47: L

1. Drive to MANUAL mode position.

2. Drive to AUTO mode position.

Rotating focusing ring by hand and hit the number key.

Set the lens drive mode selector on 'M/A'.

Return to the menu, when hit RETURN key.

Outline

Press the numeric key (1.2.) on the PC keyboard while turning the focus ring manually and check clutch motor operation and A-M mode switching operation of the clutch switch.

(9) Inspection of lens driving operation (1)

Type of lens : AF-I NIKKOR 300mm/2.8D CPU version : 2.18

Inspection of lens driving operation (2).

1. Lens driving mode. → [Normal scan drive]

2. Lens driving speed. → [Slow speed]

3. Lens driving direction. → [Inf → Close]

Change the each item setting while lens driving motor stops.

Hit SPACE key to rotate focusing motor.

Return to the menu, when hit RETURN key.

Outline

Checking lens operation is possible by normal scan drive operation. Lens driving speed can be selected from slow, medium and high speed options.

*In the normal drive operation, speed is controlled by pulses output from the glass encoder. (Drive mode in actual use)



AF-I Nikkor ED 300mm f/2.8 D IF

DISASSEMBLING / ASSEMBLING / ADJUSTMENT

- Note:**
- ① The tone of pictures may be different from actual one. Make sure of the shape of parts when disassembling and assembling.
 - ② The mark ∇ shows the position of index.
 - ③ : Disassembling / assembling
 : Adjustment
 : Additional work
 - ④ All screws mentioned in this publication are right-handed screws unless otherwise mentioned. Rotate screws counter-clockwise to unfasten, and clockwise to fasten.
 - ⑤ Send the lens back to Nikon if the front lens group (ED glass) is damaged.

FRONT LENS GROUP

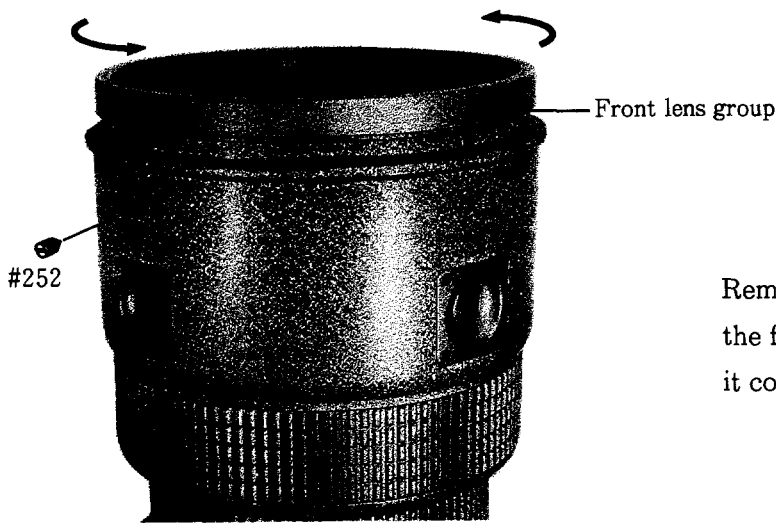

Remove screw #252 and remove the front lens group by rotating it counter-clockwise.

RING UNIT, FOCUS LOCK FPC UNIT

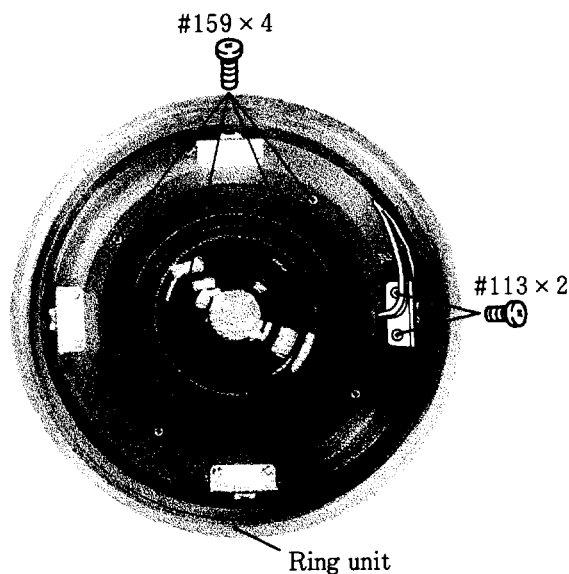

① Remove screws #113 x 2 on the switch unit with wires attached and remove soldering on the wires. (Refer to the figure below)

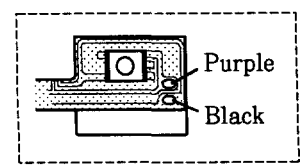

② Remove screws #159 x 4 to remove driving ring unit.

SECOND LENS GROUP, THIRD LENS GROUP

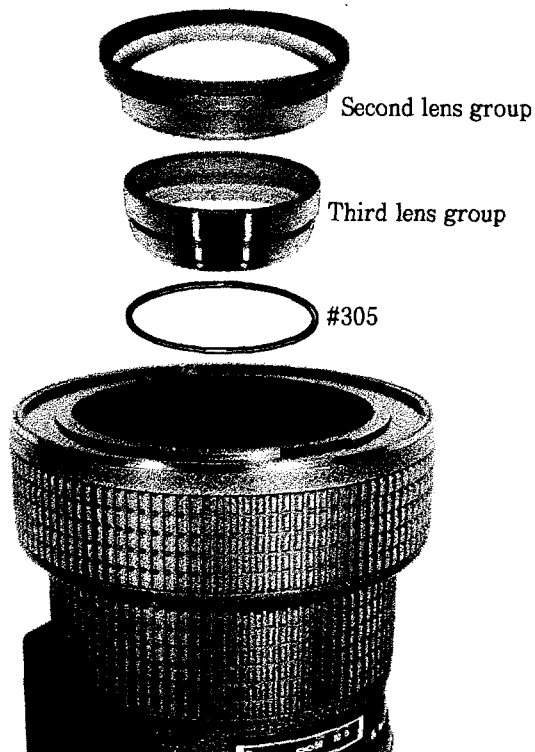

MANUAL FOCUS ENCODER BASE PLATE

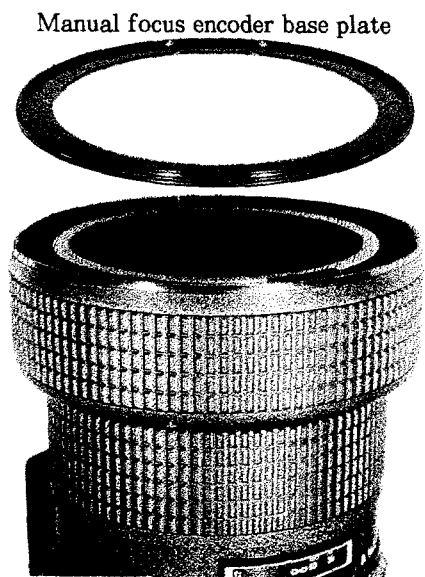

- Since the manual focus encoder base plate is secured by screw lock, use alcohol to dissolve screw lock and remove the base plate.

FOCUS RANGE SWITCH UNIT

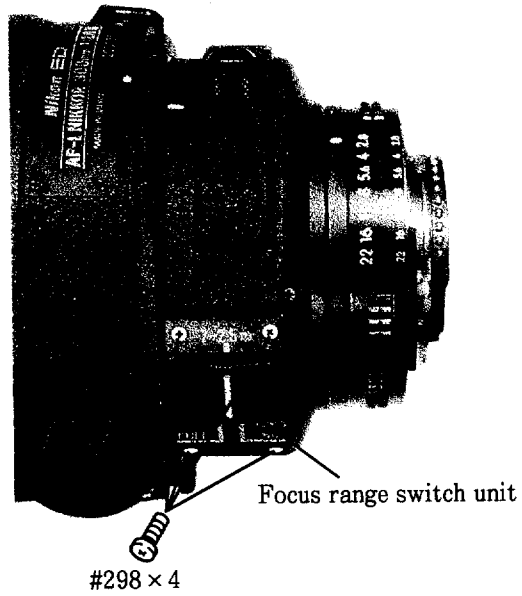

- Remove the screws #298 x 4.
- Remove the focus range switch unit and remove soldering of wires. (Refer to the figure below)

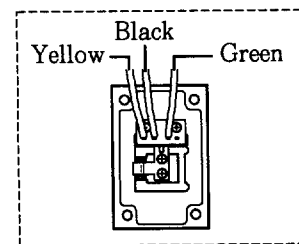

INDEX RING, TRIPOD ATTACHING, RETAINING RING

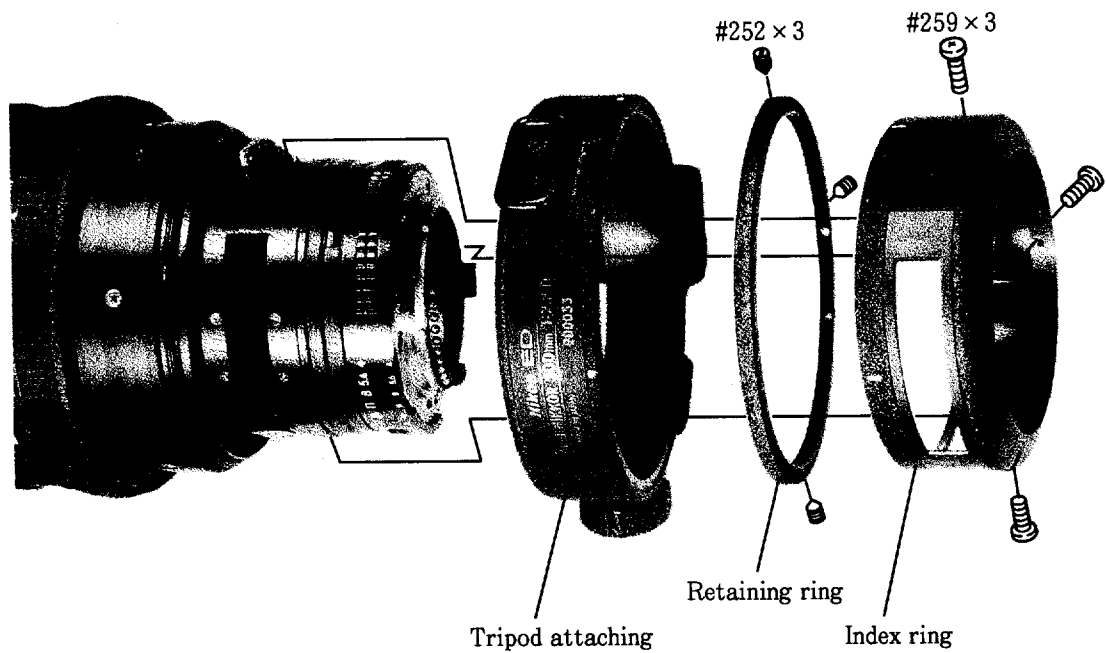

FOCUS RING

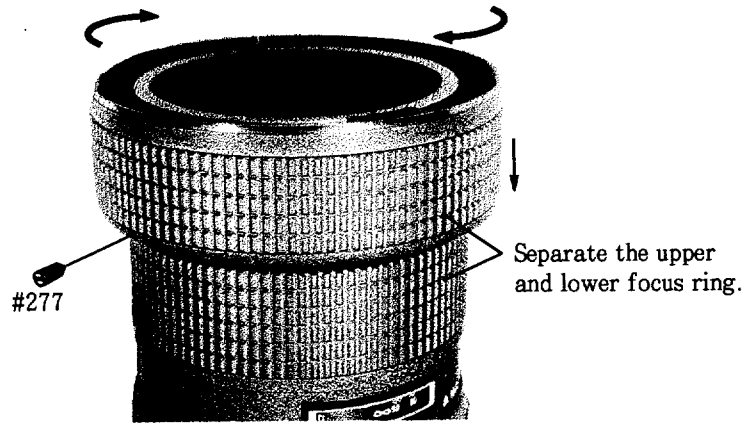

- Remove screw #277.
- Rotate the upper focus ring counter-clockwise to separate it from the lower it.
- Remove the upper focus ring toward the lower side (bayonet mount side)

FOCUS MODE INDEX RING UNIT

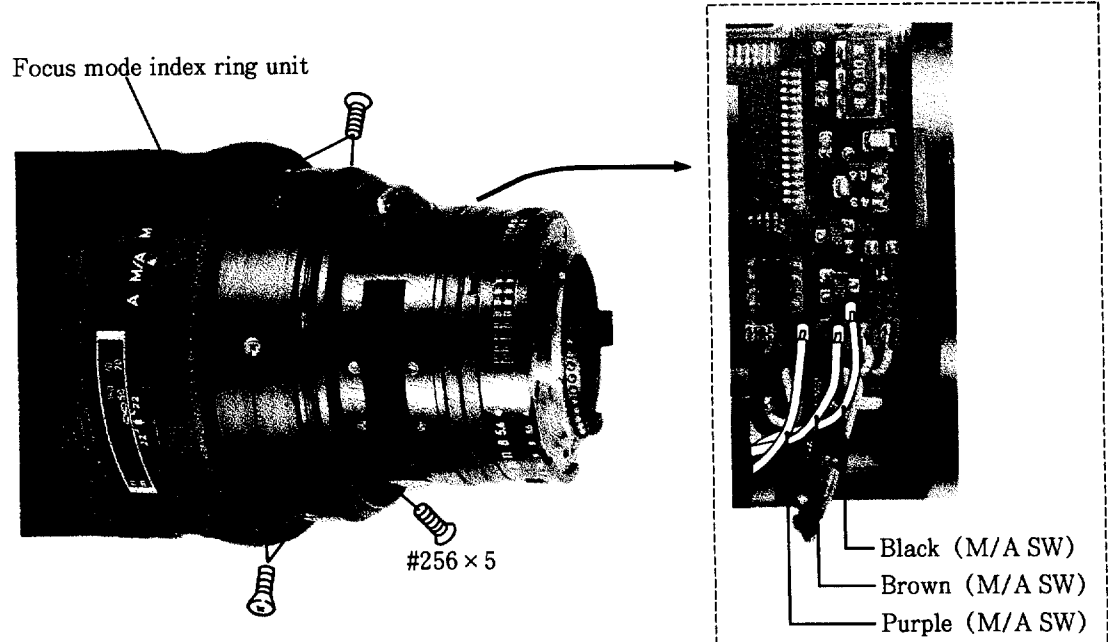

- The focus mode index ring can easily be removed at the position where the focus mode switch is adjusted to "M/A".

FIRST, SECOND LENS HOUSING UNIT, LED UNIT

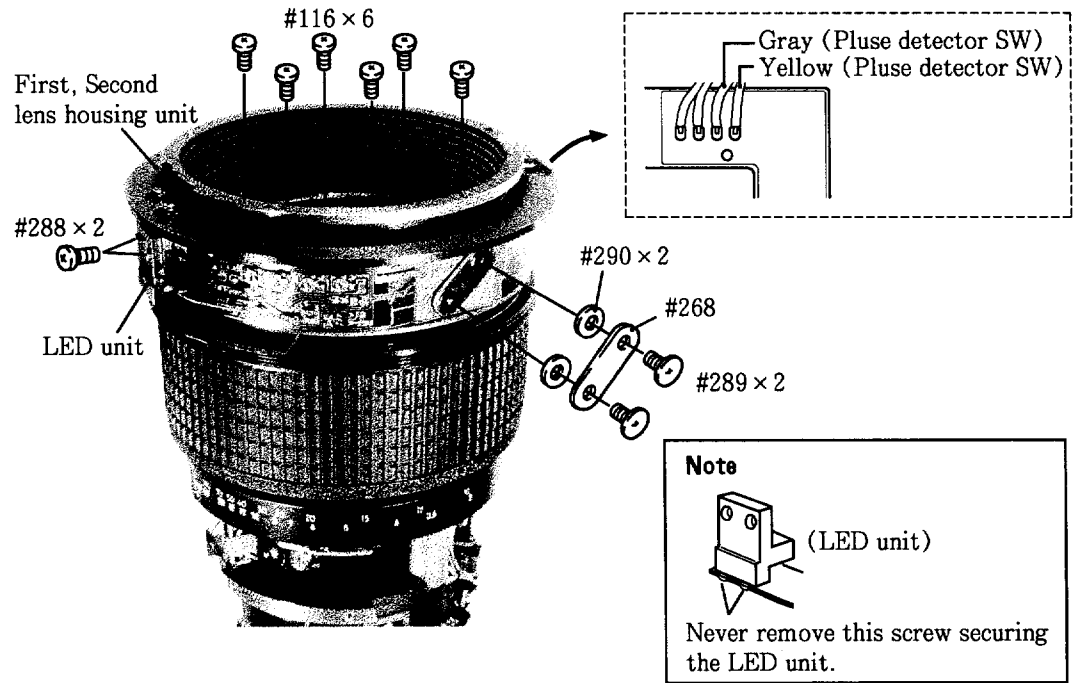

GLASS ENCODER UNIT, DISTANCE SCALE RING

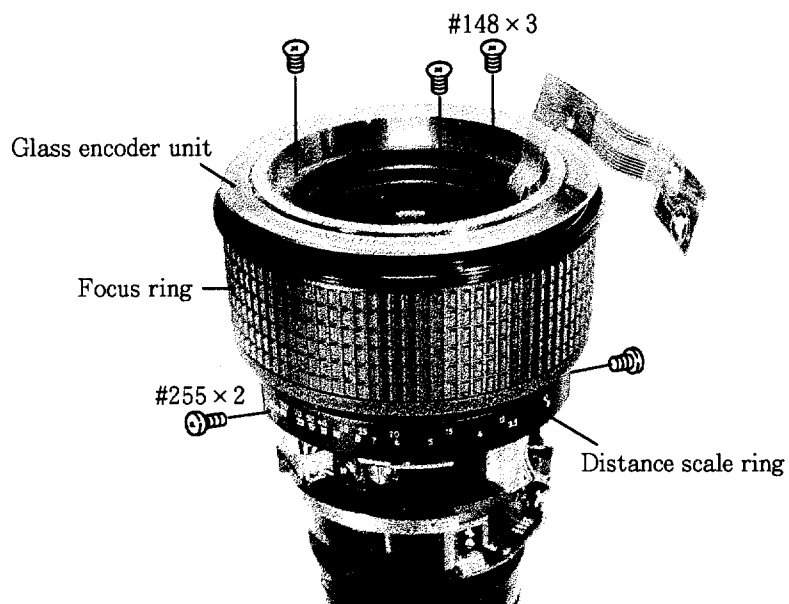

APERTURE BLADE HOUSING UNIT

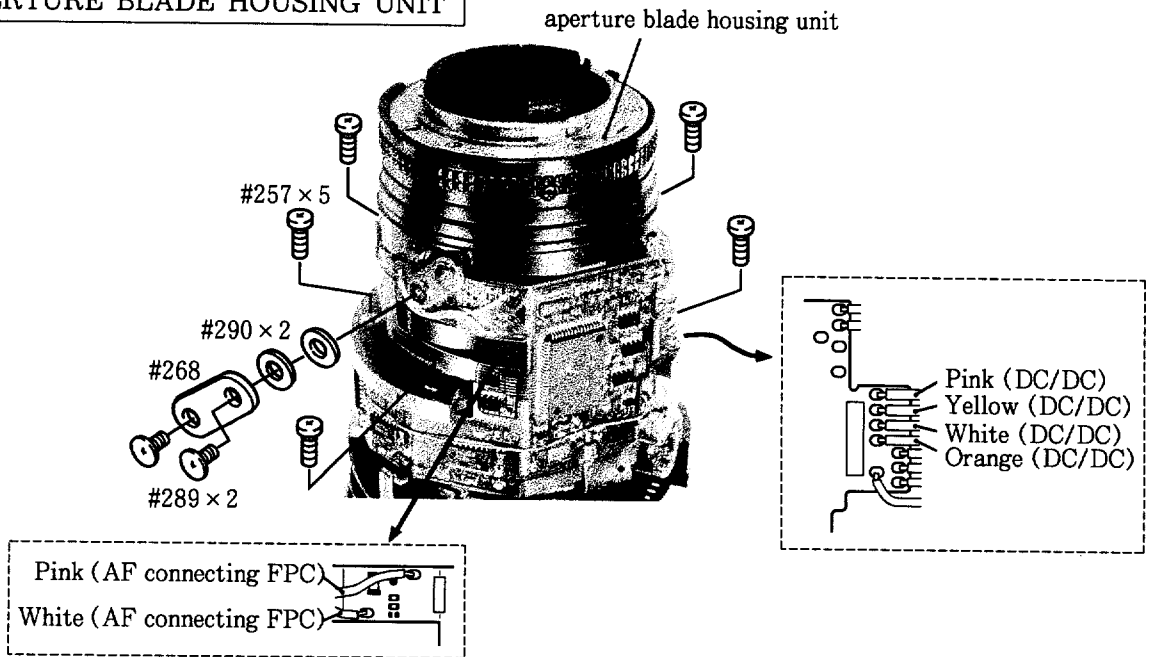

MAIN FPC

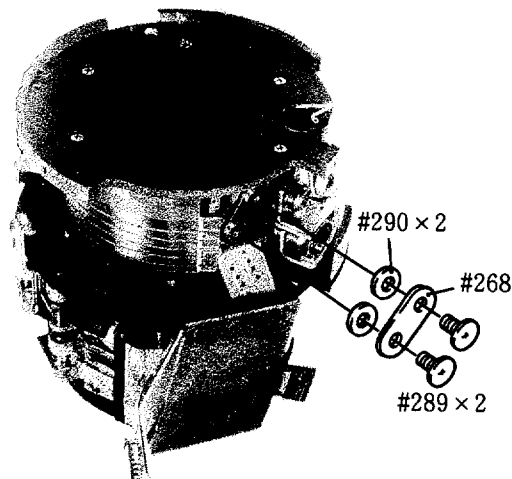
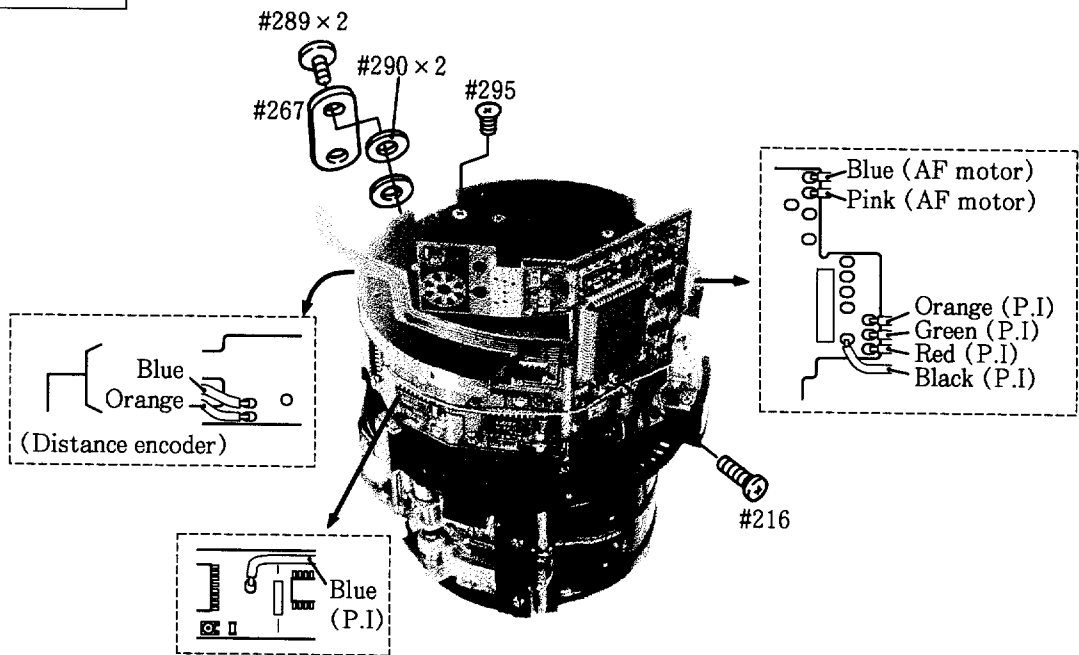

AF GEAR UNIT

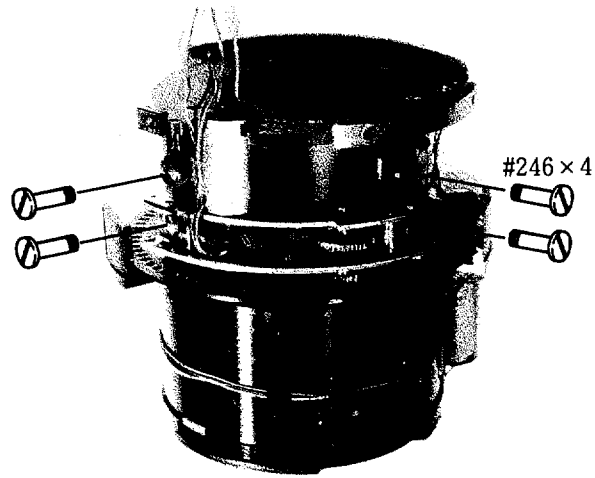

A/M SWITCH, CLUTCH MOTOR UNIT, ENCODER BRUSH UNIT

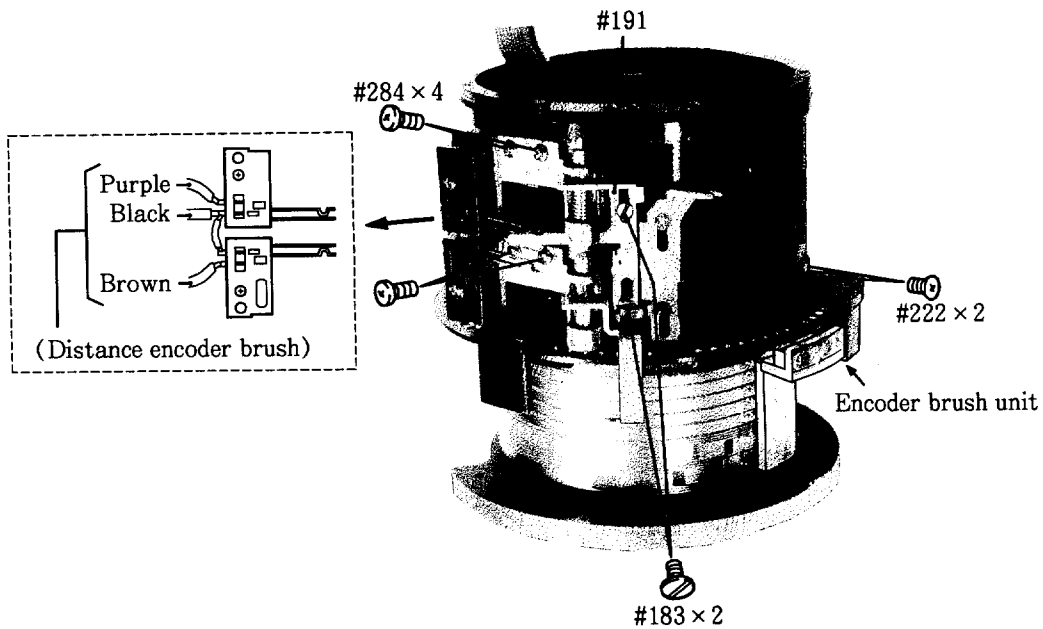
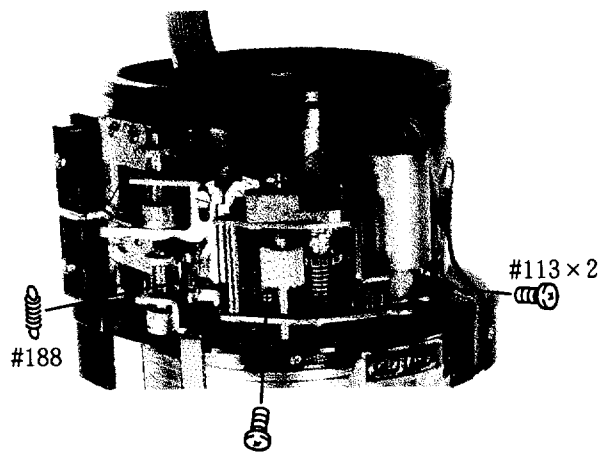

MODE RING RETAINING RING, MULTI-HOLE RING

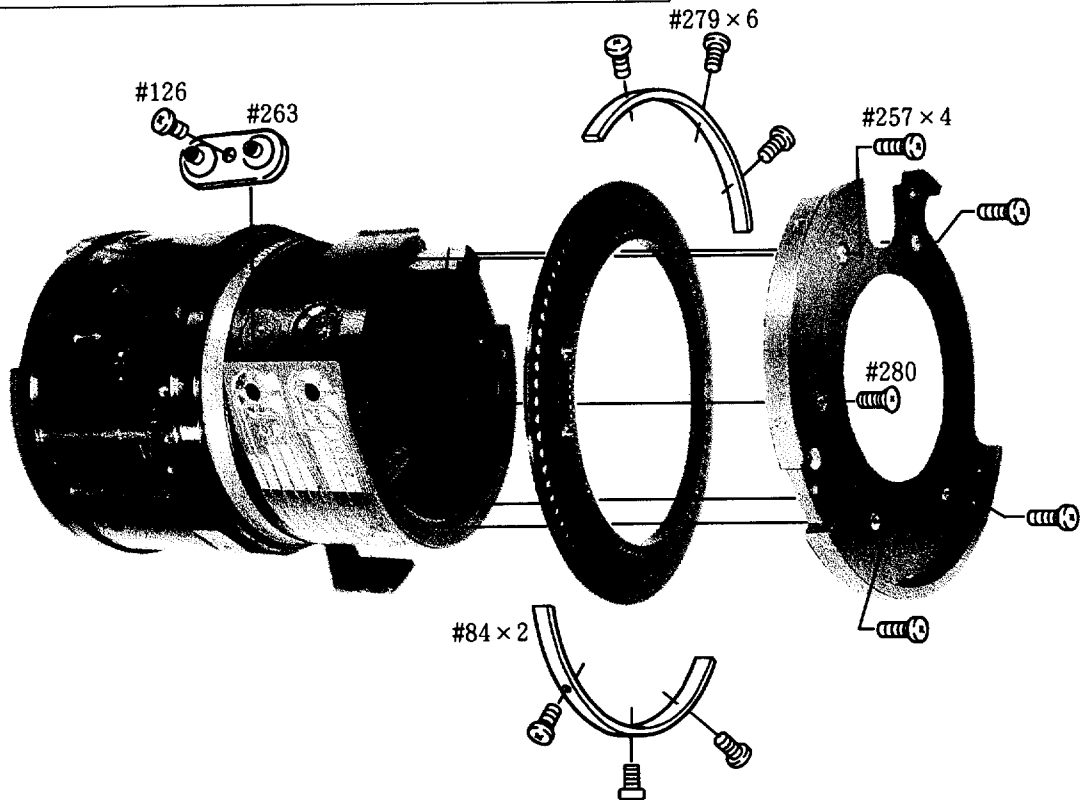

THIRD DRIVING CAM GROUP

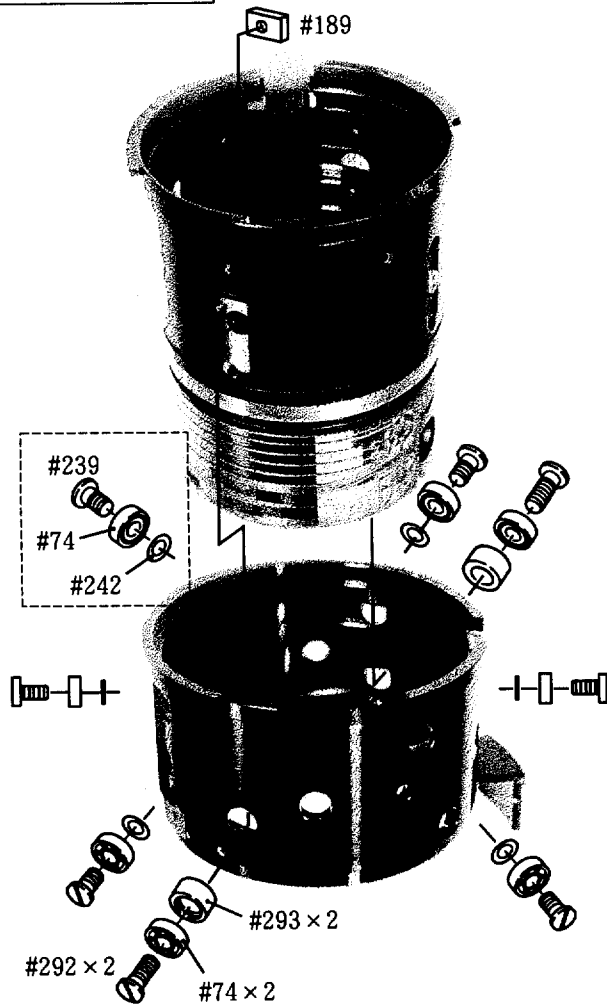

Note: Parts as shown in the picture by dotted lines are used in the lens units (produced during the initial period of volume production) at 6 portions. Later the part as shown by dotted lines are used at 3 portions and parts as shown below are used at the rest of portions.



CONNECTING FPC

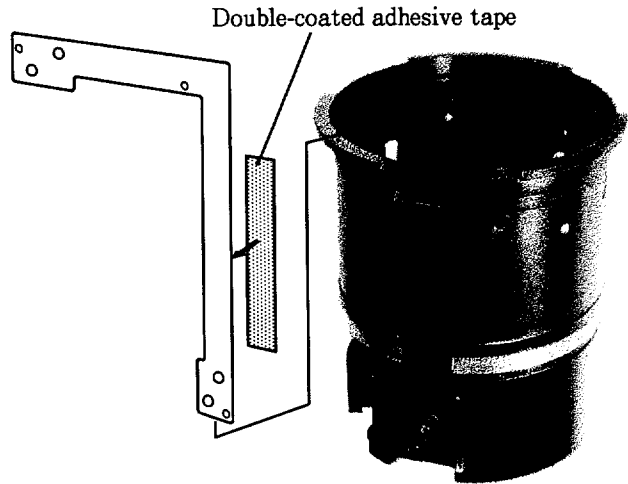

CAM RING, THIRD LENS DRIVING RING

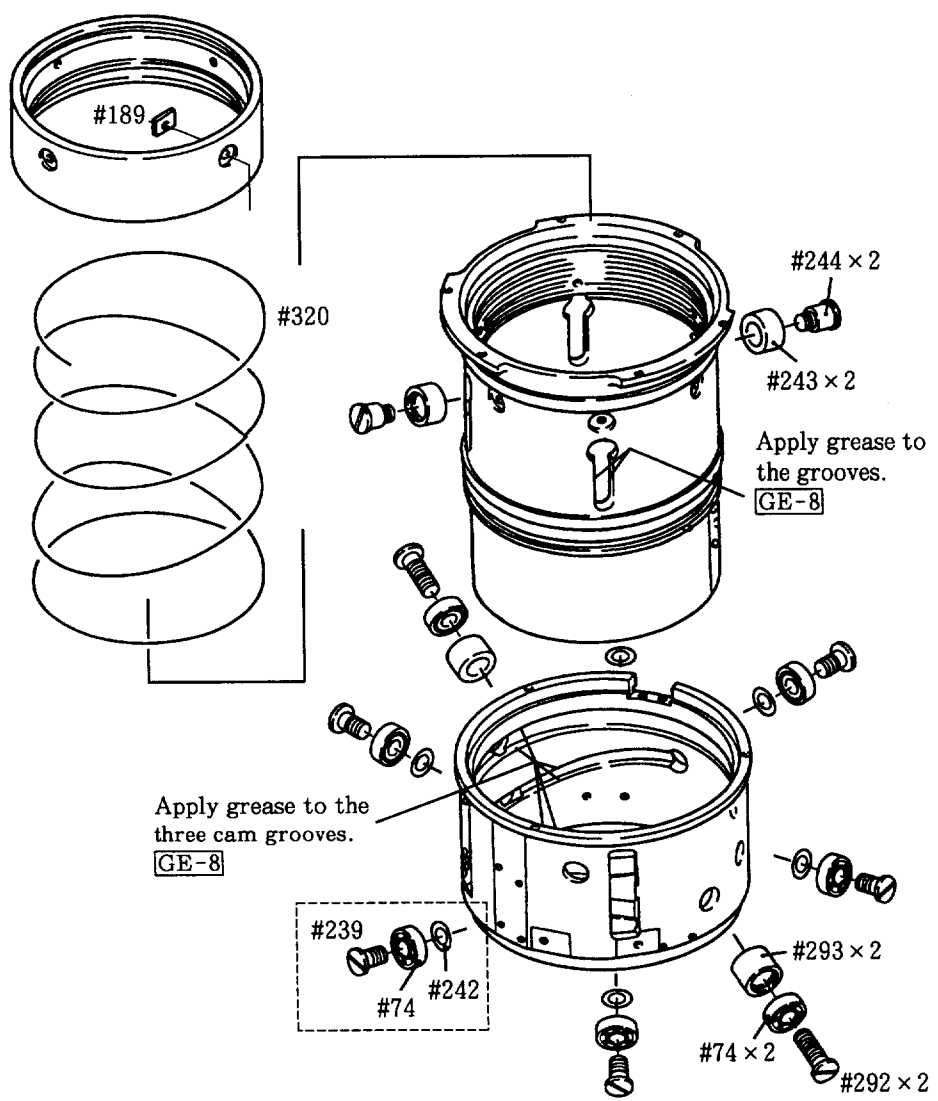

Note: Be sure to choose one of the following combinations by checking individual accuracy of overrun and servo stop operations for the parts encircled by dotted lines.

- Parts encircled by dotted lines × 6 positions.
- Parts encircled by dotted lines × 3 positions and B330 (refer to D8) × 3 positions.

MULTI-HOLE RING

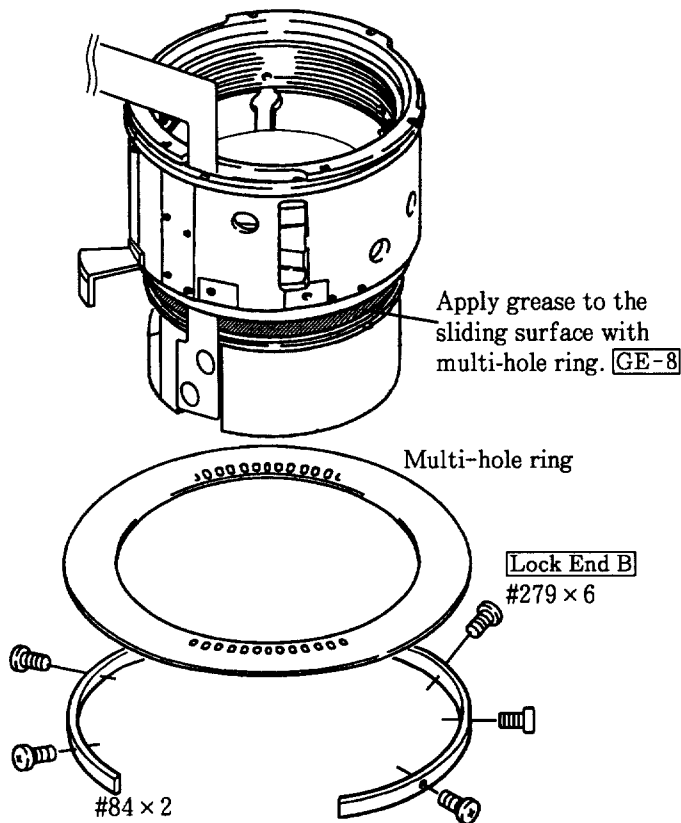

- Do not overfasten screws #279 x 6 when mounting #84 x 2 since these parts are easily deformed.

Inspection: Check that there is no mounting backlash in the porous ring.

ENCODER FPC

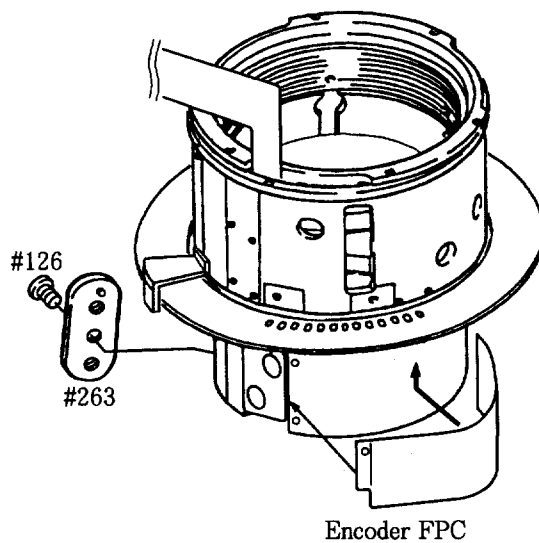

- As shown in the figure, attach the encoder FPC to the lens body while aligning both ends and moving it aside in the direction of the arrow.

ADJUSTMENT OF ENCODER BRUSH POSITION

Insert a bar about 3mm in length (such as a drill) into the hole.

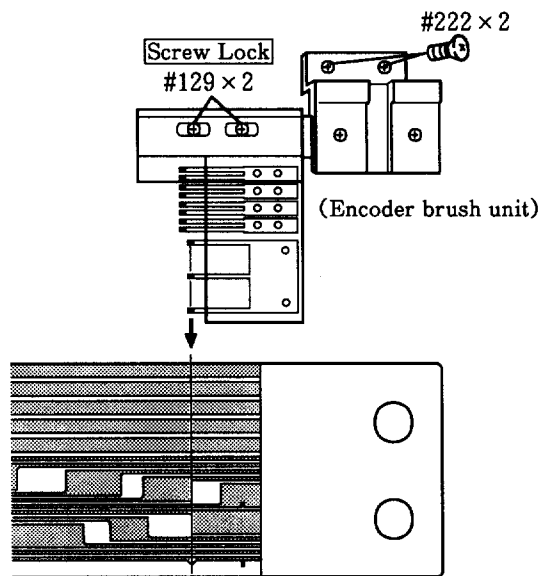
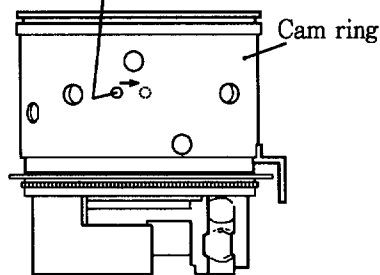

- ① Turn the cam ring to align the position of the hole.
- ② Insert a bar about 3mm in length (such as a drill) into the hole and secure the cam ring.
- ③ Attach the encoder brush unit to the cam ring.
- ④ Unfasten screws #129 x 2 and let the brush tip come into contact with the line as shown in the figure.
- ⑤ Fasten screws #129 x 2 and turn the cam ring several times to check the location of the brush.
- ⑥ Secure screws #129 x 2 using Screw Lock.

CLUTCH LATCH LEVER #107

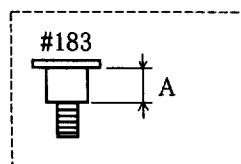
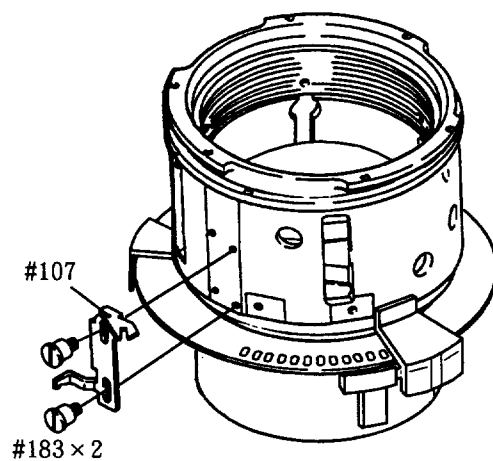

Note: Choose screws #183 x 2 from the table below while checking operation of clutch latch lever #107.

A	Parts No.	Tolerance
①	1K130-496	+0.04 -0.07
②	1K130-504	+0.07 -0.1

A/M SWITCH

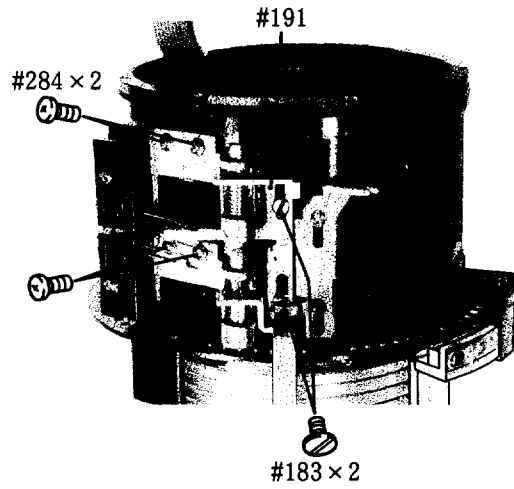

CLUTCH MOTER UNIT

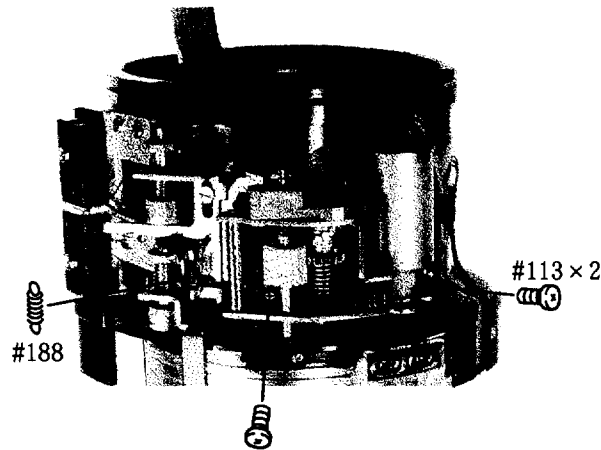

ADJUSTMENT OF CLUTCH MOTOR UNIT POSITION

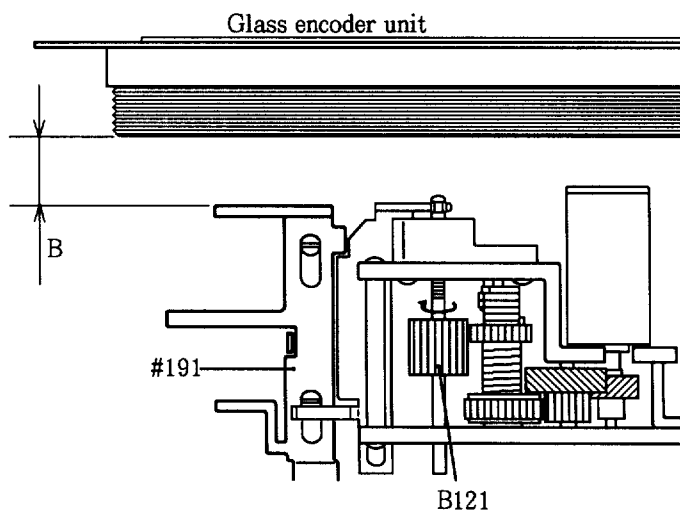

- ① Temporarily attach the glass encoder unit.
- ② Rotate gear B121 in the direction of the arrow until it comes to a stop at the stopper.
- ③ Measure the distance "B" between the end of glass encoder unit and the bar #191.
- ④ If the difference is out of the standard value, move the attachment position of the clutch motor unit to adjust the distance "B".

Standard value : 12.1 ± 0.05

A/Mスイッチ位置調整

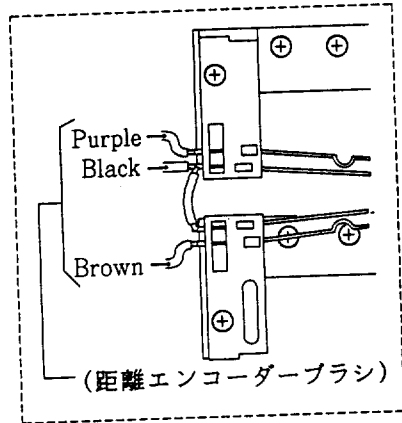
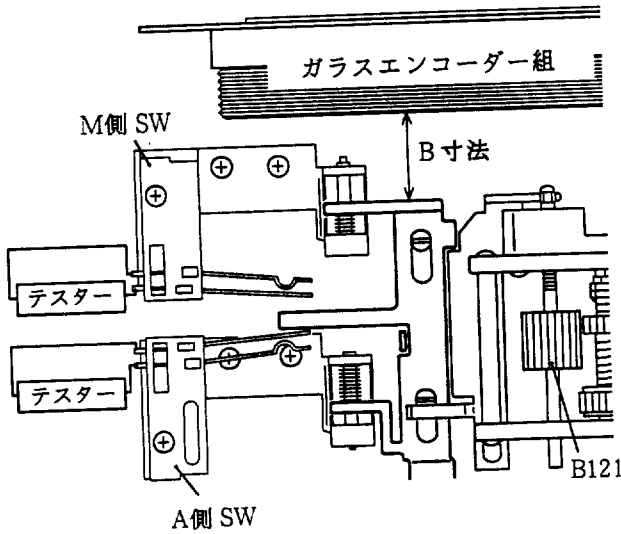

- ① M側スイッチの接片をテスターに接続する。
- ② ギア B121を回転させ、スイッチがON及びOFFする位置のB寸法を測定する。
- ③ B寸法が規格外の場合は、スイッチの取付け位置をずらす又は、接片を曲げて調整する。
- ④ ①～③の調整をA側スイッチでも行う。

規格値

A側スイッチ		M側スイッチ	
ON	OFF	ON	OFF
11.75~11.35	11.35未満	8.75~8.35	8.35以上

- ⑤ 調整後、A/Mスイッチにコードを半田付けする。

- ⚠ ● 修理方法が変更されています。下記の資料を参照して下さい。
- ① 製品技術資料 93F-2032
 - ② サービス技報 サ93-48

モードリング保持環

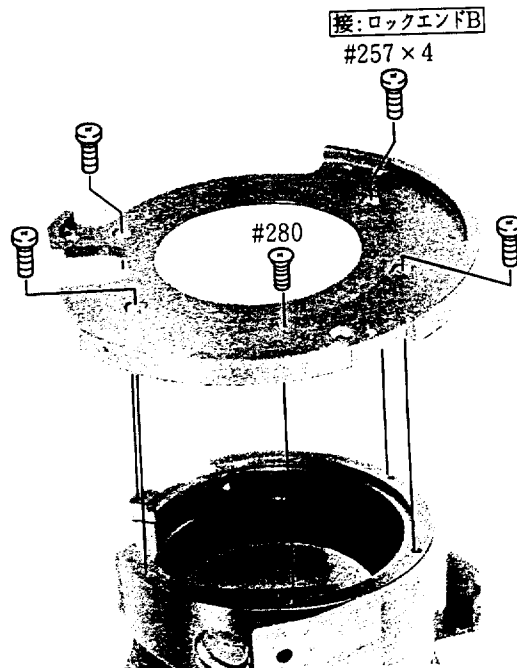

ADJUSTMENT OF A/M SWITCH POSITION

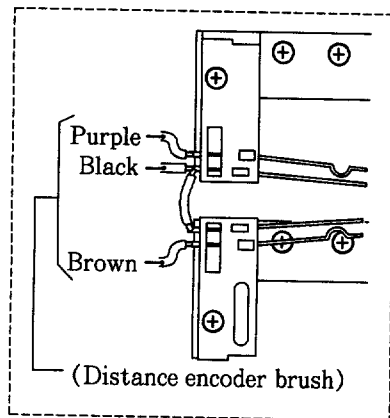
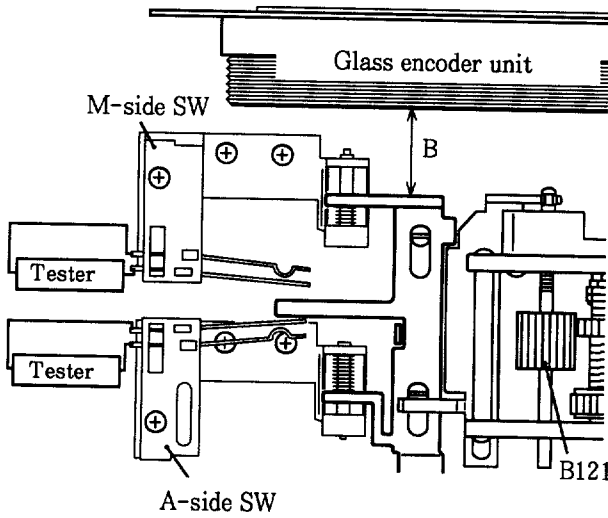

- ① Connect the contact of the M-side switch to the tester.
- ② Rotate gear B121 and measure the distance "B" where the switch turns ON and OFF.
- ③ If the distance "B" is out of the standard value, move the attachment position of the switch or adjust the distance by bending the contact.
- ④ Perform the same procedures ① ~ ③ for A-side switch.

Standard value

A-side switch		M-side switch	
ON	OFF	ON	OFF
11.75~11.35	11.35 Less	8.75~8.35	8.35 Over

- ⑤ After adjustment, solder the wire and the A/M switch.

MODE RING RETAINING RING

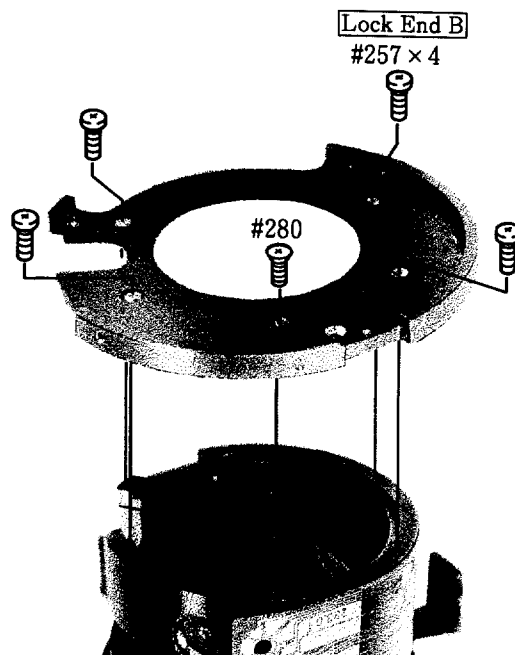

AF GEAR UNIT

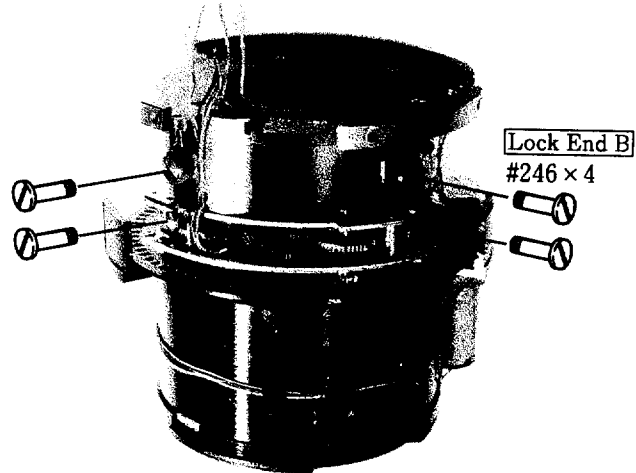

Inspection:
After attaching the AF gear unit,
check rotation operation.

MAIN FPC

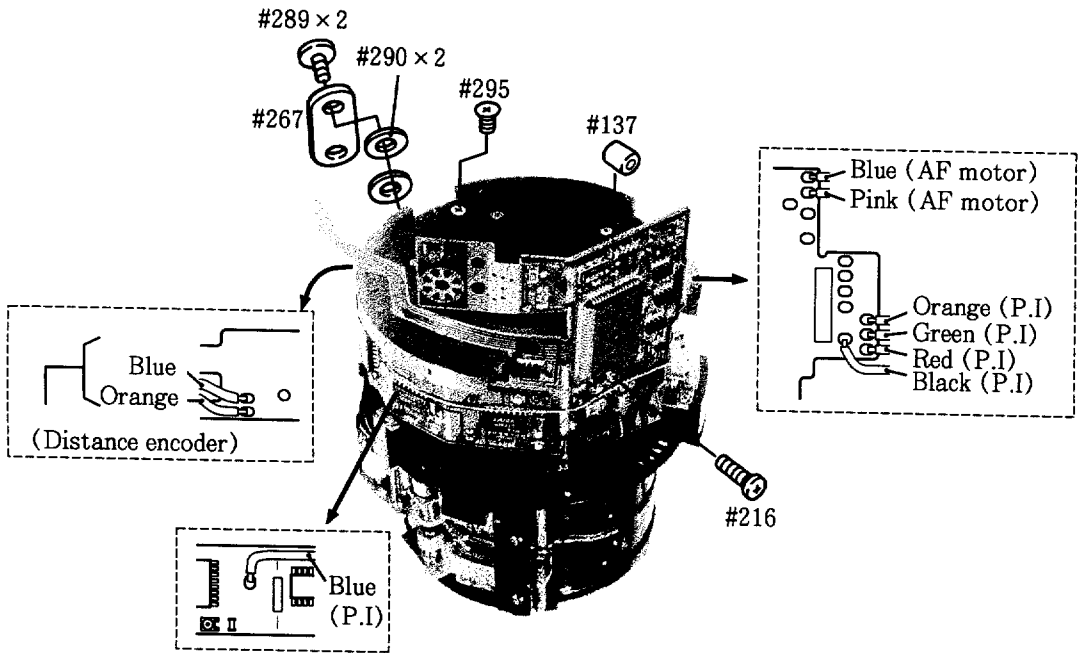
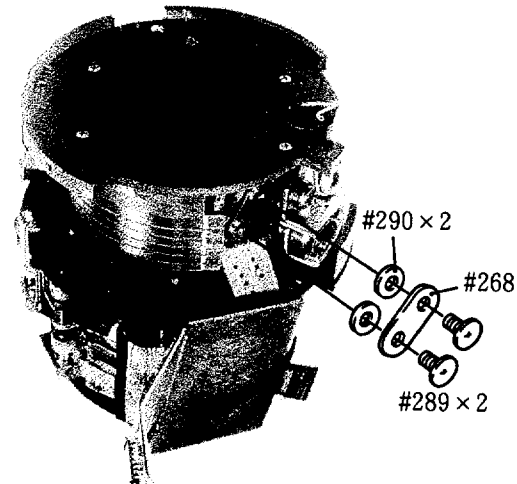

APERTURE BLADE GROUP

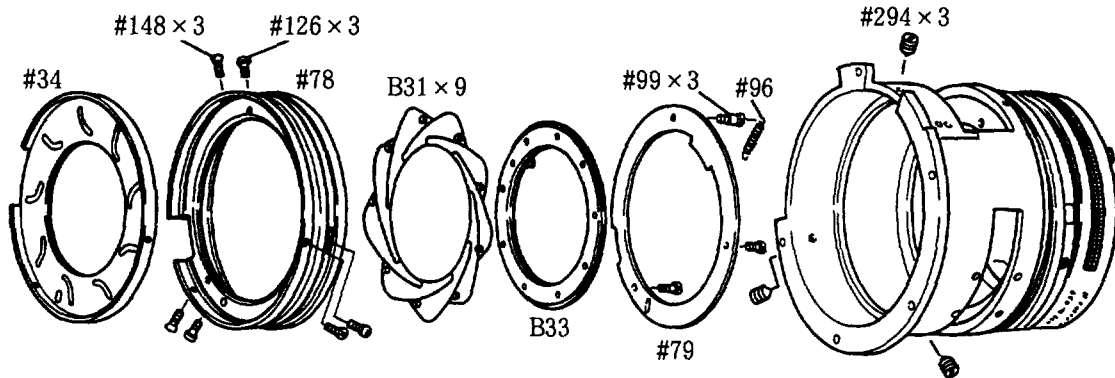

ADJUSTMENT OF APERTURE OPENING

- ① Unfasten screws #294×3 and move part #34 to adjust the aperture diameter. As a guide to adjustment, the full aperture (f/2.8) should be the same size as the inside diameter of part #34. (The inside diameter of part #34 is 35.92mm, the same as that of inscribed circle diameter.)
 - Aperture diameter should be within the allowable range when the aperture ring is rotated forward and backward.
 - Aperture lever should be within the allowable range when the aperture lever is snapped by your finger.
- ② After adjustment, secure screws #294×3 using Screw Lock.

Aperture setting	Inscribed circle diameter (mm)	Tolerance (mm)
2.8	35.92	37.16 ~ 34.76
4	24.68	26.66 ~ 22.85
5.6	17.42	19.55 ~ 15.52
8	12.31	13.82 ~ 10.97
11	8.71	10.15 ~ 7.46
16	6.16	7.18 ~ 5.28
22	4.35	5.08 ~ 3.73

ADJUSTMENT OF APERTURE LEVER POSITION

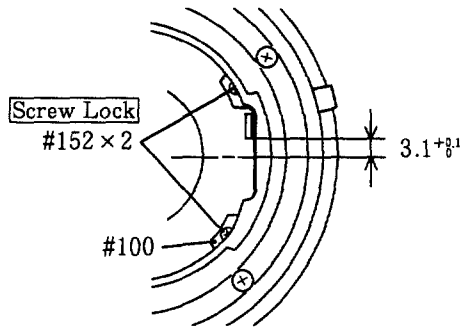

Unfasten screws #152 x 2 to adjust the position of the aperture lever #100 so that it comes into the rated value of $3.1^{+0.1}$ to bring the aperture diameter within rated value at full aperture. Together with this, adjust the horizontal position so that it does not come in contact with the bayonet mount and rear cover ring. After adjustment, fix screws #152 x 2 using Screw Lock.

Reference: When adjusting the rated value of $3.1^{+0.1}$, set the aperture ring to f/2.8 and mount the tool J18004-1 on the bayonet mount. It becomes much easier to adjust if you mount the aperture lever based on the groove of the tool as a reference.

APERTURE BLADE HOUSING UNIT

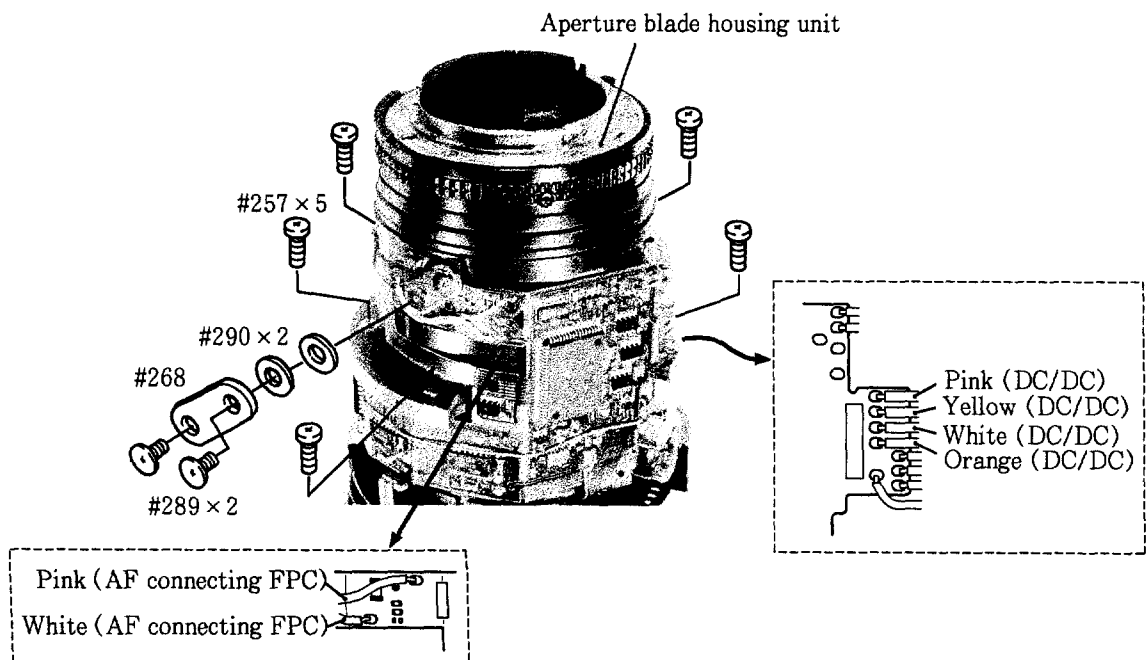

GLASS ENCODER UNIT, DISTANCE SCALE RING

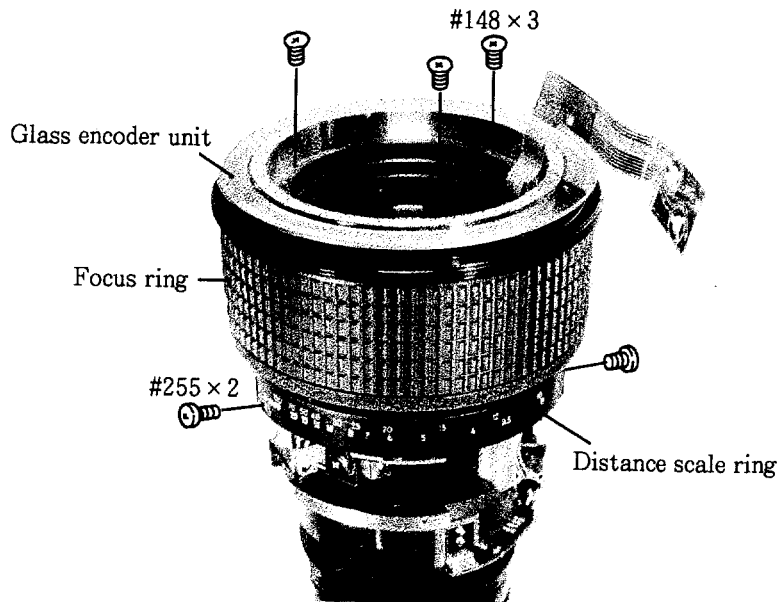

FIRST, SECOND LENS HOUSING UNIT

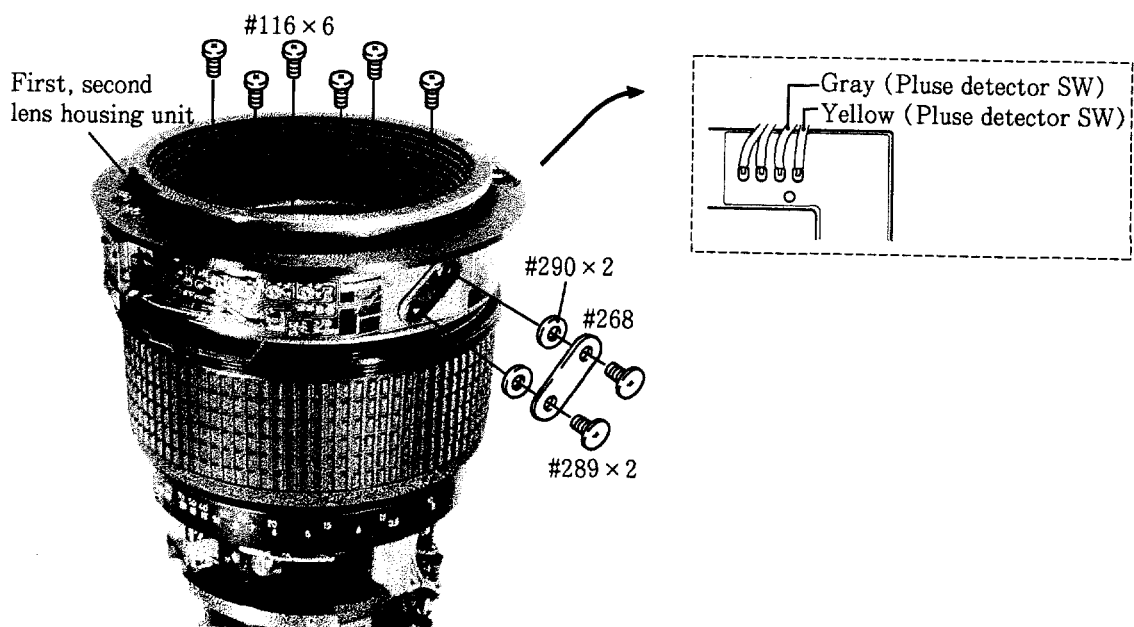

ADJUSTMENT OF GAP BETWEEN THE LED AND THE GLASS ENCODER

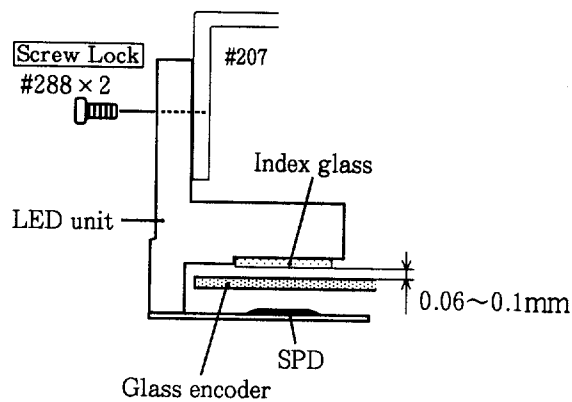

① Insert a 0.06 ~ 0.1mm thick spacer between the LED (index glass) and the glass encoder. Then fasten screws #288 × 2 to secure.

② Move the lens from near to infinity manually to check the gap between the LED (index glass) and the glass encoder and their parallelism.

Reference: Bend #207 to adjust when it is difficult to obtain parallelism.

③ Secure screws #288 × 2 using Screw Lock.

THIRD LENS GROUP

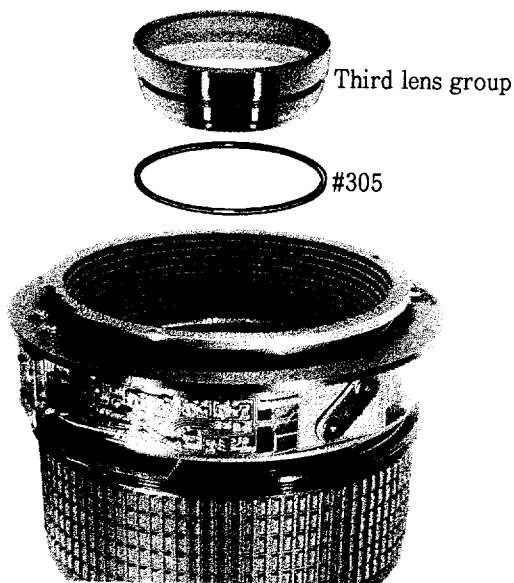

Note: As operation depends on whether or not the third lens unit is present, mount the third lens unit before inspecting lens operation.

INSPECTING LENS OPERATION

- Mount the lens on the camera body (F90 or F4) and check operation.

Note: If no communication is obtained between the camera body and the lens, it is possible that the wiring in the lens is incorrect. Check all wiring.

ADJUSTMENT

- Items to be adjusted

1. Phase difference and position adjustment between the glass encoder and the index glass.
2. Inspection and adjustment of play in the lens driving gear.
3. Inspection of lens driving stop accuracy (overrun) and the lens servo control time.

- Tools to be used

1. J18231 : AF-I lens inspection software
2. J15306 : AF-I lens communication box
3. J15307 : AF-I lens communication adapter
4. Personal computer (NEC PC-9800 series)
5. DC regulated power supplies × 2
6. 4ch digital storage oscilloscope

[Settings]

① Inspection equipment

Refer to the specifications for further details.

Note: Connect the AF-I lens communication box to the RS-232C interface located on the rear panel of the personal computer.

② Operating voltage

	Power supply for lens AFmotor	Power supply for AF-I lens communication box
Overrun inspection	6.5V ± 0.1	5.5V ± 0.2
Servo control stop time inspection	5.5V ± 0.1	
Scanning time inspection	6.0V ± 0.1	

1. Phase difference and position adjustment between the glass encoder and the index glass

Do not touch these parts as they have been factory adjusted.

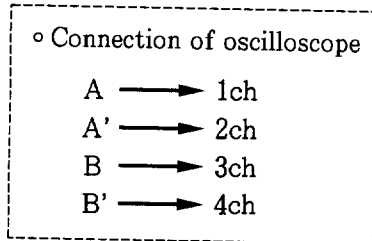
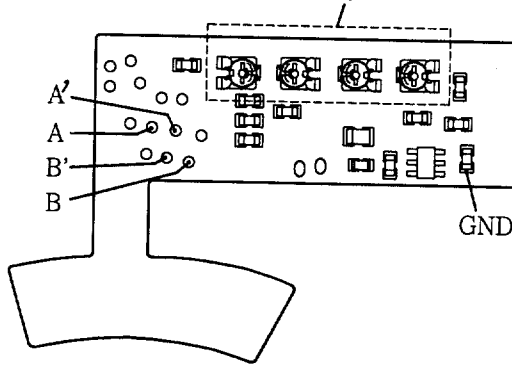

Position adjustment

① Adjust check lands, as shown in the left-hand figure, and each channel of the oscilloscope so that A, A', B and B' output (sinusoidal) waveforms can be monitored on the oscilloscope.

o Setting oscilloscope (reference values)

VOLTS/DIV	200mV
TIME/DIV	/ 0.5 ms

② Inspection of each switch and lens condition from the main menu on the personal computer screen.

③ Turn the focusing ring to check the four waveforms. If the waveforms correspond to one of the items described in the following table, readjust the gap between the index glass and the glass encoder. (Refer to "Adjustment of gap between the LED and the glass encoder".)

	Phenomenon	Cause	Adjustment
Fig 1.	Amplitude of four waveforms is different.	Gap between the glass encoder and the index glass is not parallel.	Bend #207.
Fig 2.	Amplitude of waveforms is abnormally large. There is almost no gap between phases.	No opening between the glass encoder and the index glass. They come into contact.	Check opening and make adjustment once again (0.06 ~ 0.1mm)
Fig 3.	Amplitude of four waveforms is abnormally small.	Too great an gap between the glass encoder and the index glass (more than 0.1 mm).	

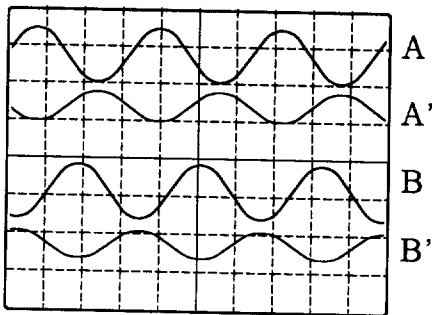

Fig 1.

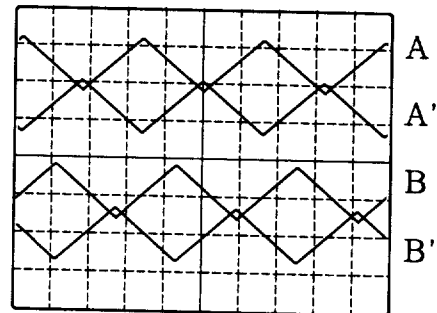

Fig 2.

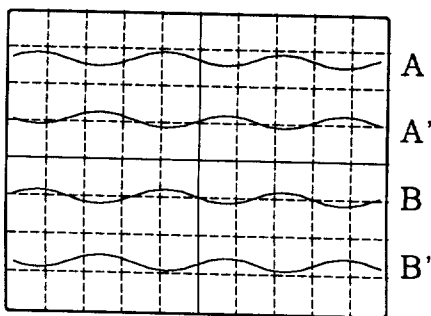
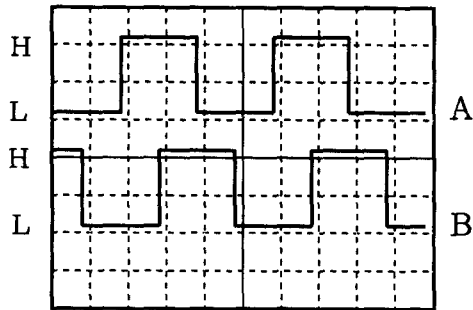

Fig 3.



Inspection of hot line output

- ① Connect the H-terminal of the AF-I lens communication box to the 1-ch terminal of the oscilloscope, and connect the E-terminal to the 2-ch terminal.

◦ Setting of oscilloscope (reference value)

VOLTS/DIV	2 0.5 V
TIME/DIV	1 200 ms

- ② Select " 4. Inspection of hot line signal output " from the main menu on the personal computer screen, and select " 4. Inspection of E, H output " from the sub menu.

- ③ Monitor the hot line output while the focusing ring is being turned from infinity to near.

- Check the ratio of H and L for each A and B phase.

Standard ratio H: L = 1:1 ~ 4:3

- Phase A should advance by 90° against B phase.

Standard ratio: Within 90° ± 30°

Discrimination method: Edge of waveform in phase B should be within the range of T/3 of waveform in phase A.

Note: When the focusing ring is turned from near to infinity, phase B advances by 90° against phase A.

- If the output value is out of the standard value, go back to " 11. Adjustment of phase difference " on page A14 and repeat the adjustment procedures.

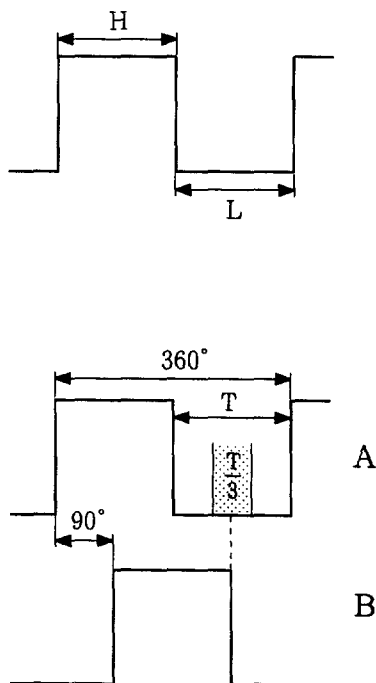

2. Inspection and adjustment of play in lens driving gear

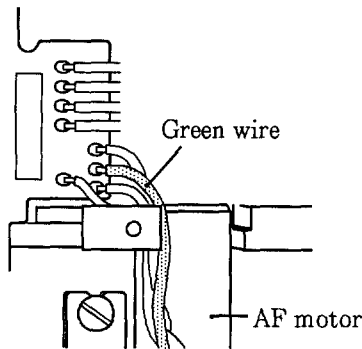

- ① Connect a green wire from the photointerruptor to the 1-ch of the oscilloscope and connect the E-terminal of the AF-I lens communication box to the 2-ch of the oscilloscope.

◦ Setting oscilloscope (reference values)

VOLTS/DIV	0.5V
TIME/DIV	5mS

- ② Select "Inspection of the play in lens driving gear." from the main menu on the personal computer screen, and monitor each waveform while moving the lens from infinity to near according to the instructions on the computer screen.

Read out pulse signal within this range.

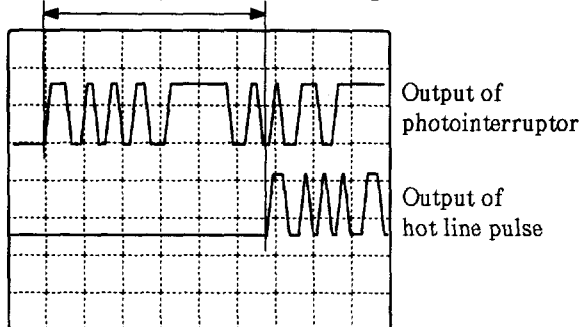

- ③ Read out the number of pulses of the photointerruptor until the hot line pulse is output.

Standard value: within 10 pulses

Reference: Optimum value can be obtained when pulse numbers are counted from 5 ~ 10.

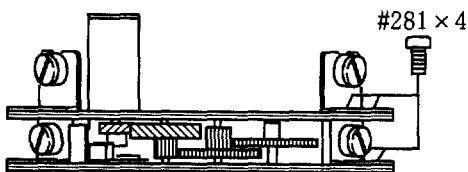

(AF gear unit)

- ④ If the value is out of the standard value, unfasten screws #281 x 4 to adjust the mounting position of the AF gear unit.

3. Inspection of lens driving stop accuracy (overrun) and the lens servo control time

* Choose one of the following inspection items and carry out inspections according to the flowcharts (No. 1 and No. 2).

Note: Fix the lens in the horizontal plane when carrying out inspections to eliminate variations due to attitude.

No. 1:

When replacing a cam ring and a guide ring (bearing), or the main FPC, or when replacing parts for repair.

No. 2:

When carrying out lens accuracy inspections if focusing is defective.

Reference: Relationship between overrun and inspection and adjustment of lens servo control time.

Contents Adjustment item	Defective in overrun	Defective in lens servo control time.
Software option	Small Large ←-----	Small Large -----→
Mechanical torque	(Guide ring, bearing) Small Large -----→	(Guide ring, bearing) Small Large ←-----

*Occurrence of defective phenomenon decreases according to the direction of the arrows.

No 1:

When replacing a cam ring and a guide ring (bearing), or the main FPC, or when replacing parts for repair.

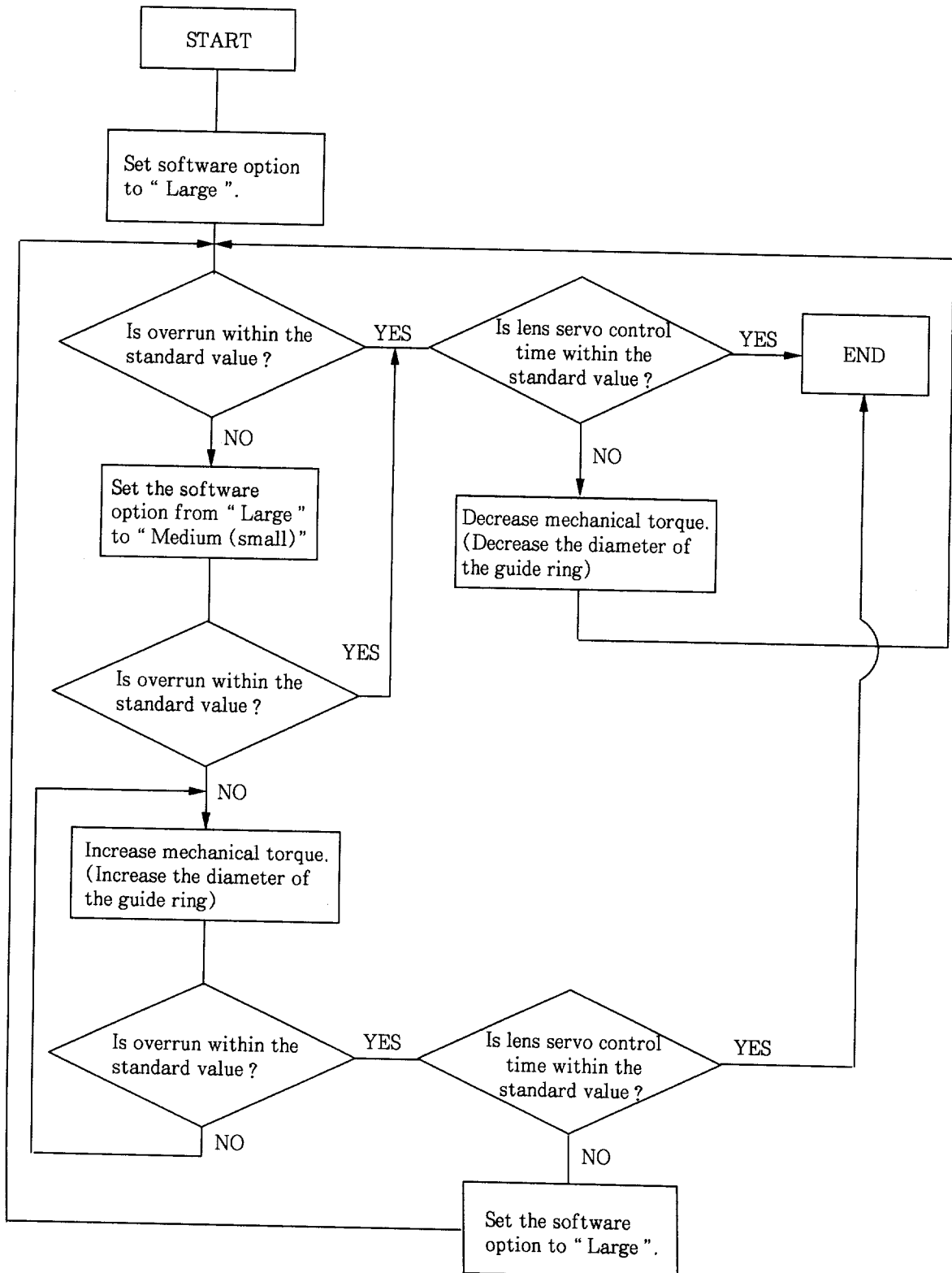

No 2:

When carrying out lens accuracy inspections if focusing is defective.

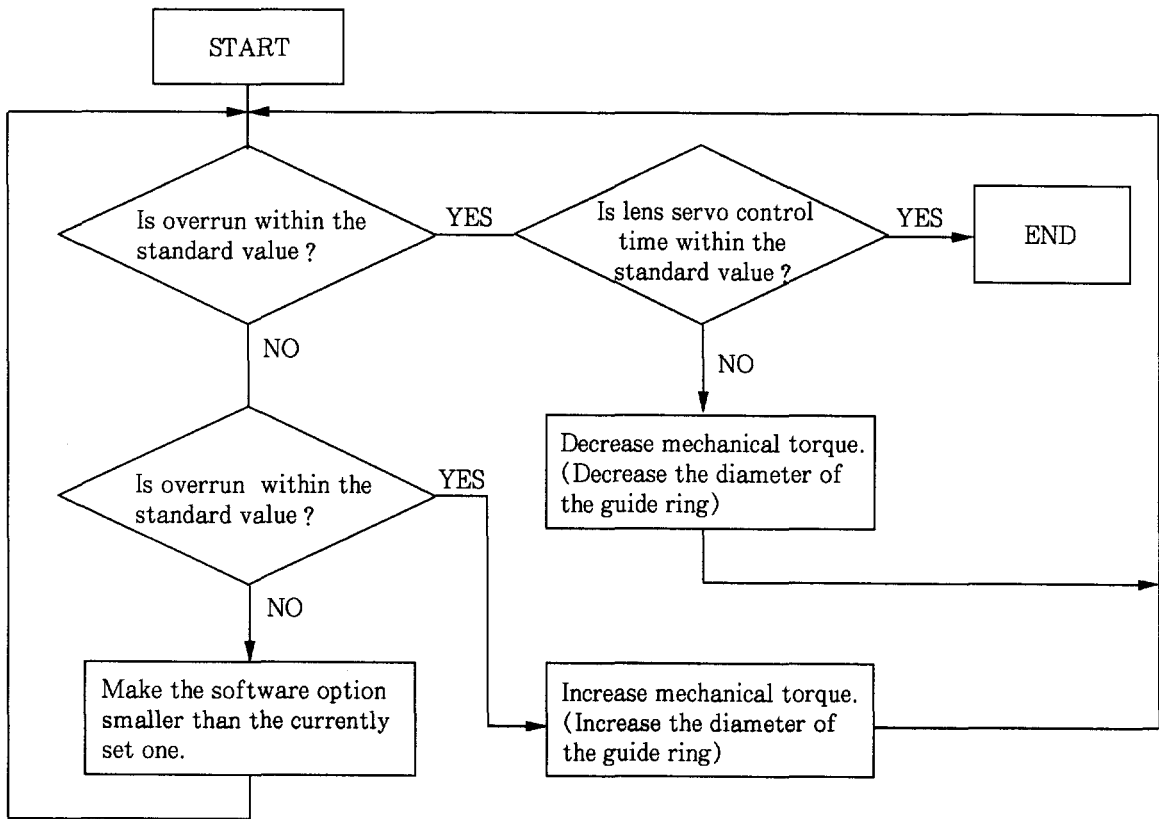

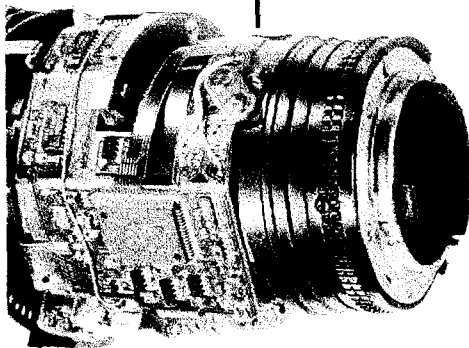
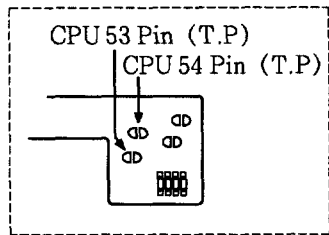

① Software option adjustment

- Software option adjustment is available on CPU ver. 2.15 or later.
- As shown in the table below, adjust software option by short-circuiting the test pattern (T.P.) between pin 53 and pin 54 of the CPU using a solder bridge.

53 Pin (T.P)	54 Pin (T.P)	Software class
Short-circuit	Short-circuit	Small
Open circuit	Short-circuit	⋮
Open circuit	Open circuit	Large

② Mechanical torque adjustment

- Set bearings × 6 or bearings × 3 and guide rings × 3 to adjust mechanical torque.
- To set the torque to the minimum value, use bearings at all six places. To make the torque greater, choose the larger diameter guide ring from the combination of bearings × 3 and guide rings × 3.

Note: Mount bearings and guide rings alternately when using them in combination.

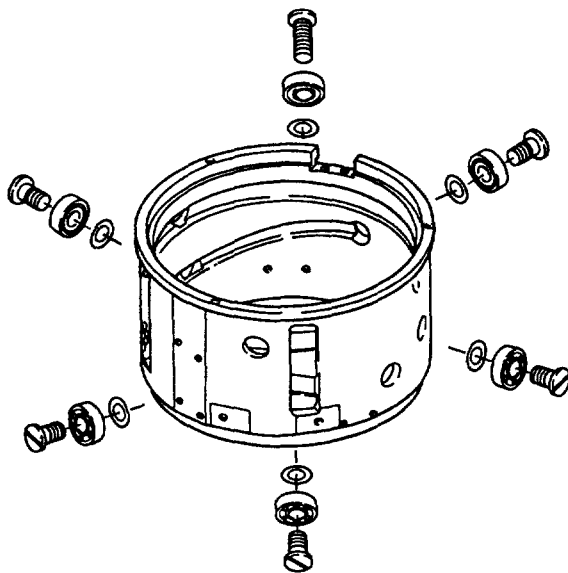

◦ Types and dimensions of guide rings

Parts No	Dimensions
1B999-534	5 ± 0.04 mm
1B999-535	5 ± 0.02 mm
1B999-536	5 ± 0.02 mm
1B999-537	5 ± 0.01 mm
1B999-538	$5 - 0.01$ mm

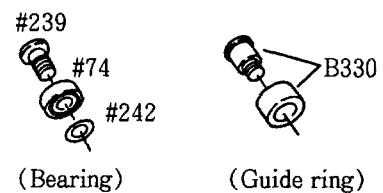

- If accuracy cannot be obtained when mechanical torque adjustment has been carried out on CPU ver. 2.14, replace CPU ver. 2.14 with CPU ver. 2.20, and carry out adjustments described in No. 1 above.

When replacing a part listed below, some adjustment and inspection may be required

Item to be check and adjusted Parts replaced		Inspection and adjustment of the glass encoder unit		Inspection of play in the lens driving gear	Inspection of accuracy in halting of the lens drive (overrun) *1.	Inspection of lens servo control time *1.
		Phase difference	Output signal adjustment			
Assembly	Main FPC Ver ~2.14					
	Main FPC Ver 2.15~				○	○
	HIC FPC	○	○		○	○
	AF connecting FPC					
	Relay FPC	○	○		○	○
	Distance encoder					
	Glass encoder	○	○		○	○
	DC/DC converter					
Part	CPU (Ver ~2.14)					
	CPU (Ver 2.15~)				○	○
	AF driving motor			○		
	Photo interrupter (P.I)			○		
	MD IC					
	Guide ring or bearing				○	○
	Focus ring	○	○		○	○

*1. Adjustment is possible with software option for CPU ver. 2.15 or later for the 300/2.8 lens.

FOCUS MODE INDEX RING UNIT

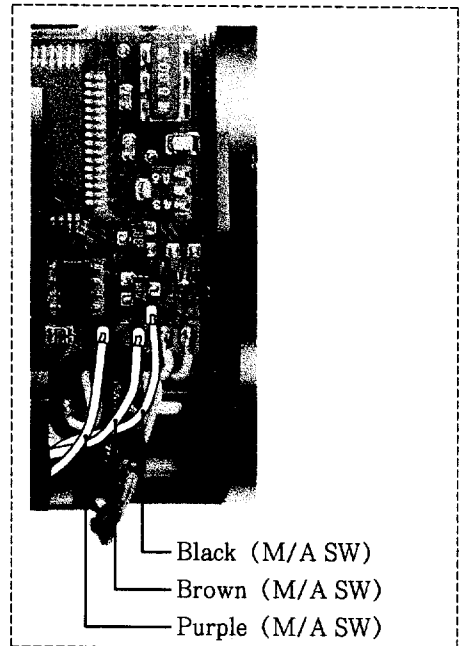
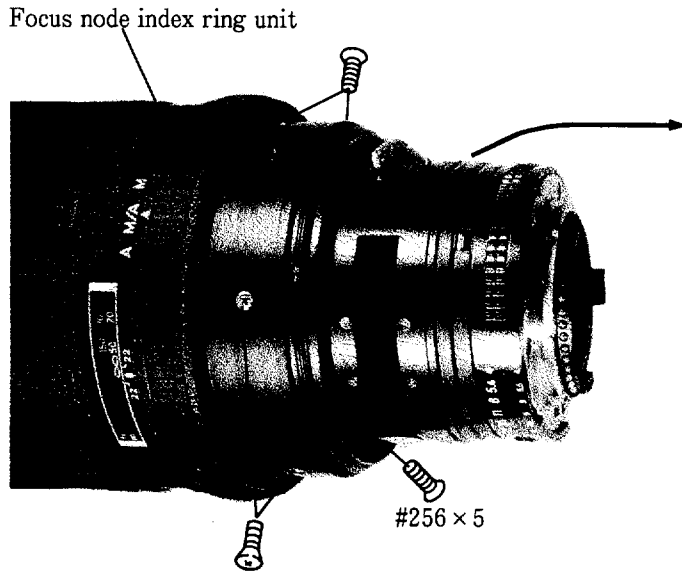

- Mount the focus mode index ring at the position where the focus mode selector is set to "M/A".

FOCUS RING

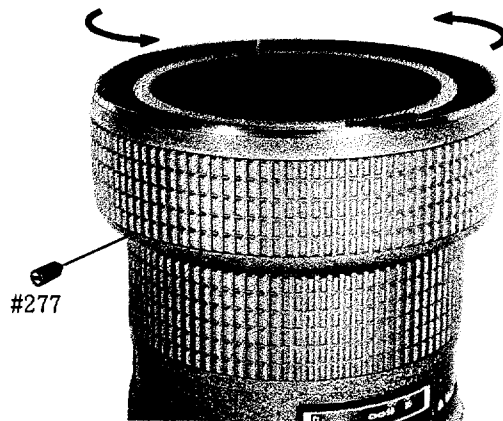

- Mount the focusing ring and secure it with screw #277.

INDEX RING, TRIPOD ATTACHING, RETAINING RING

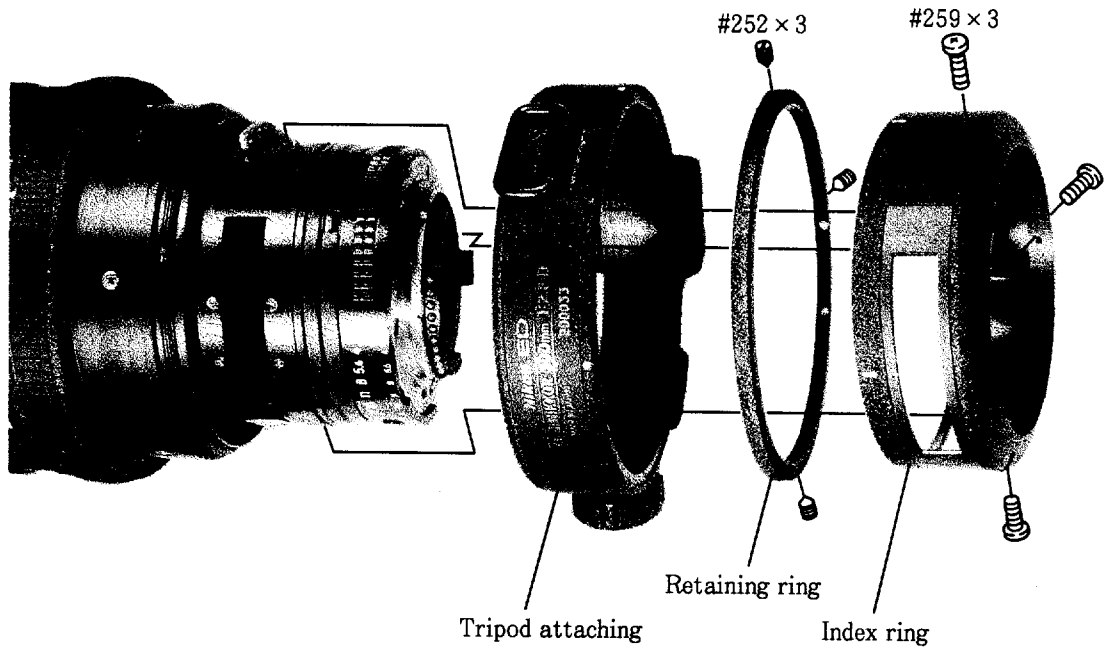

FOCUS RANGE SWITCH UNIT

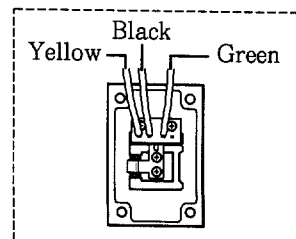
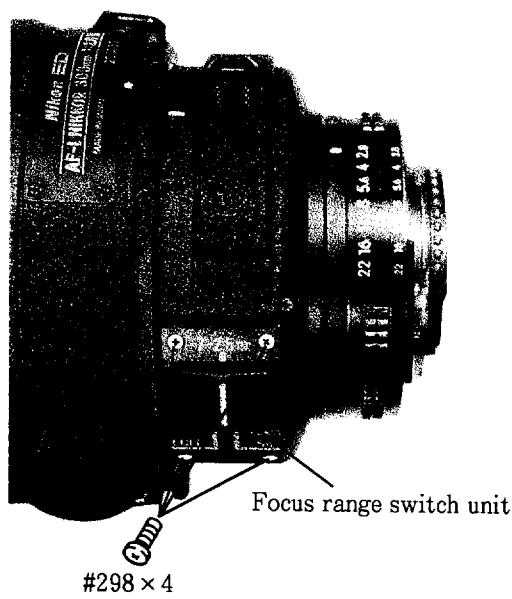

MANUAL FOCUS ENCODER BASE PLATE

Manual focus encoder base plate



SECOND LENS GROUP

Second lens group

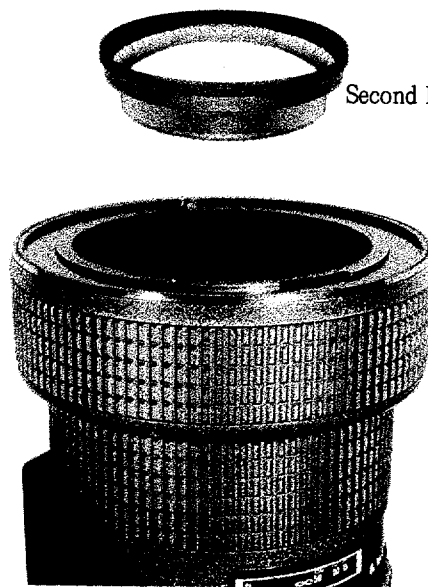

RING UNIT, FOCUS LOCK FPC UNIT

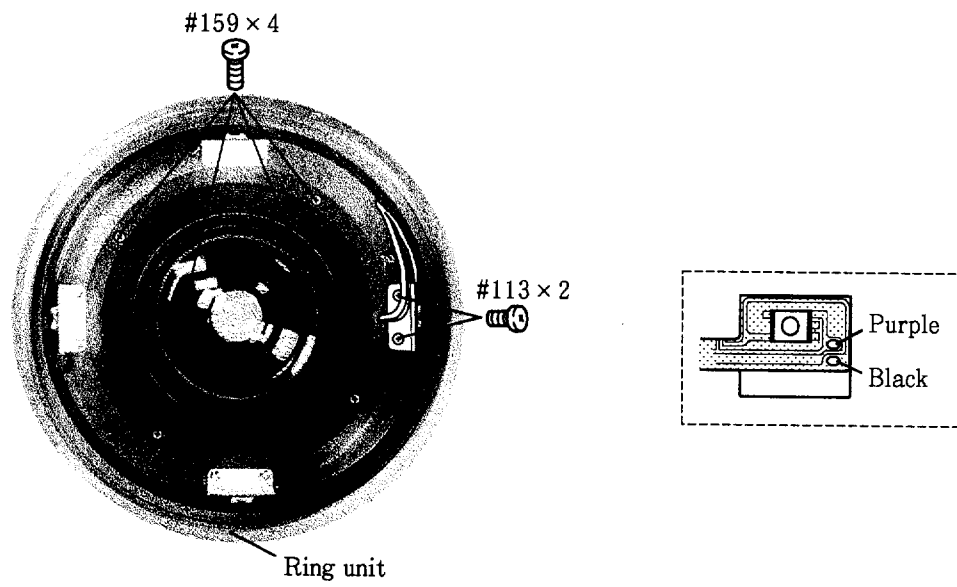

FRONT LENS GROUP

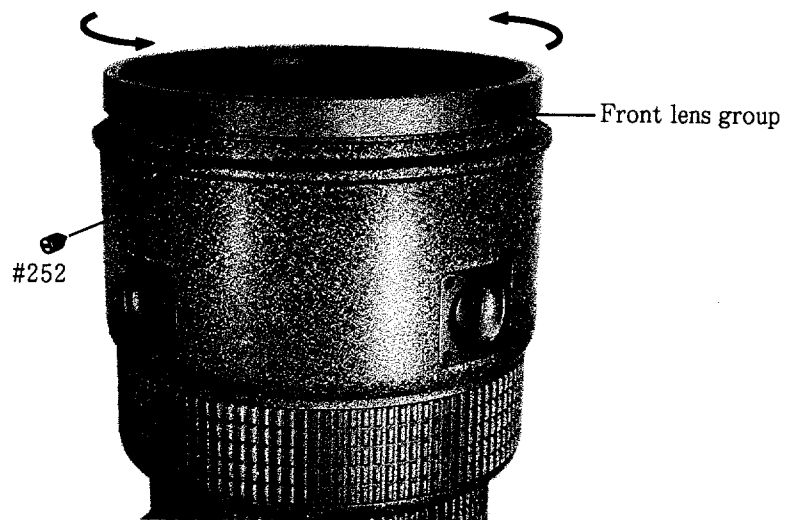

実体配線図/WIRING DIAGRAM

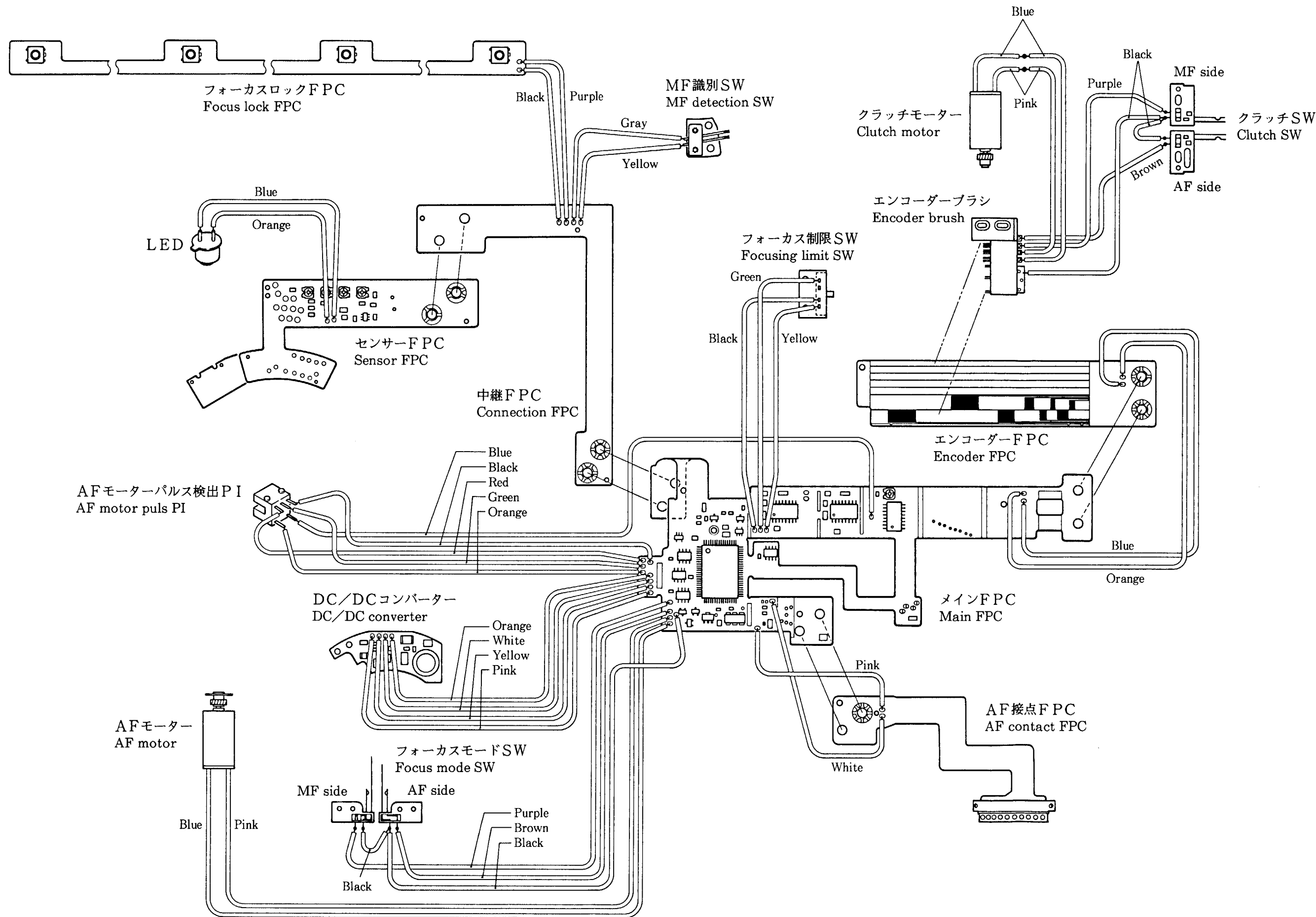

回路図 Circuit Diagram

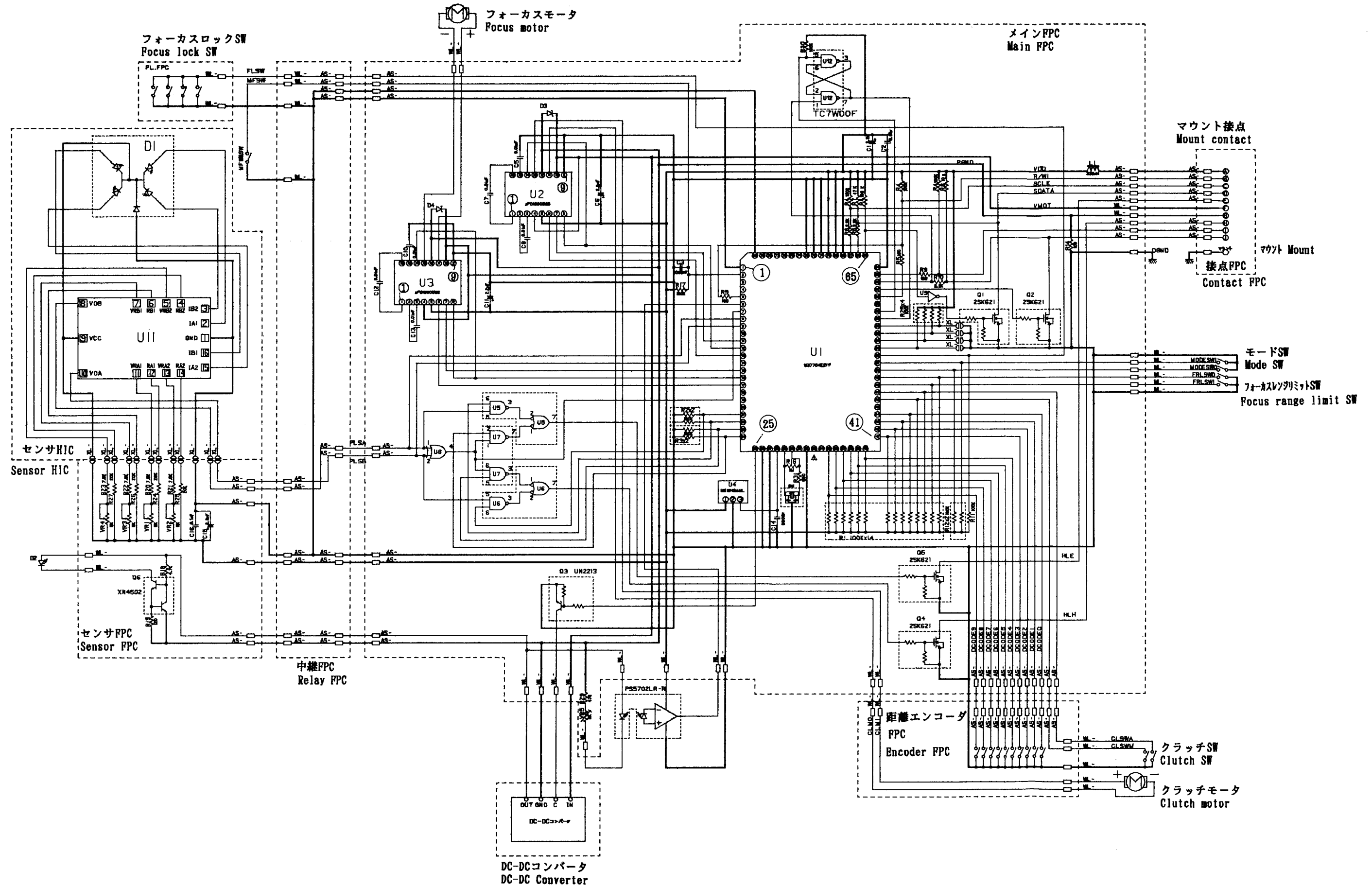

MAIN FPC

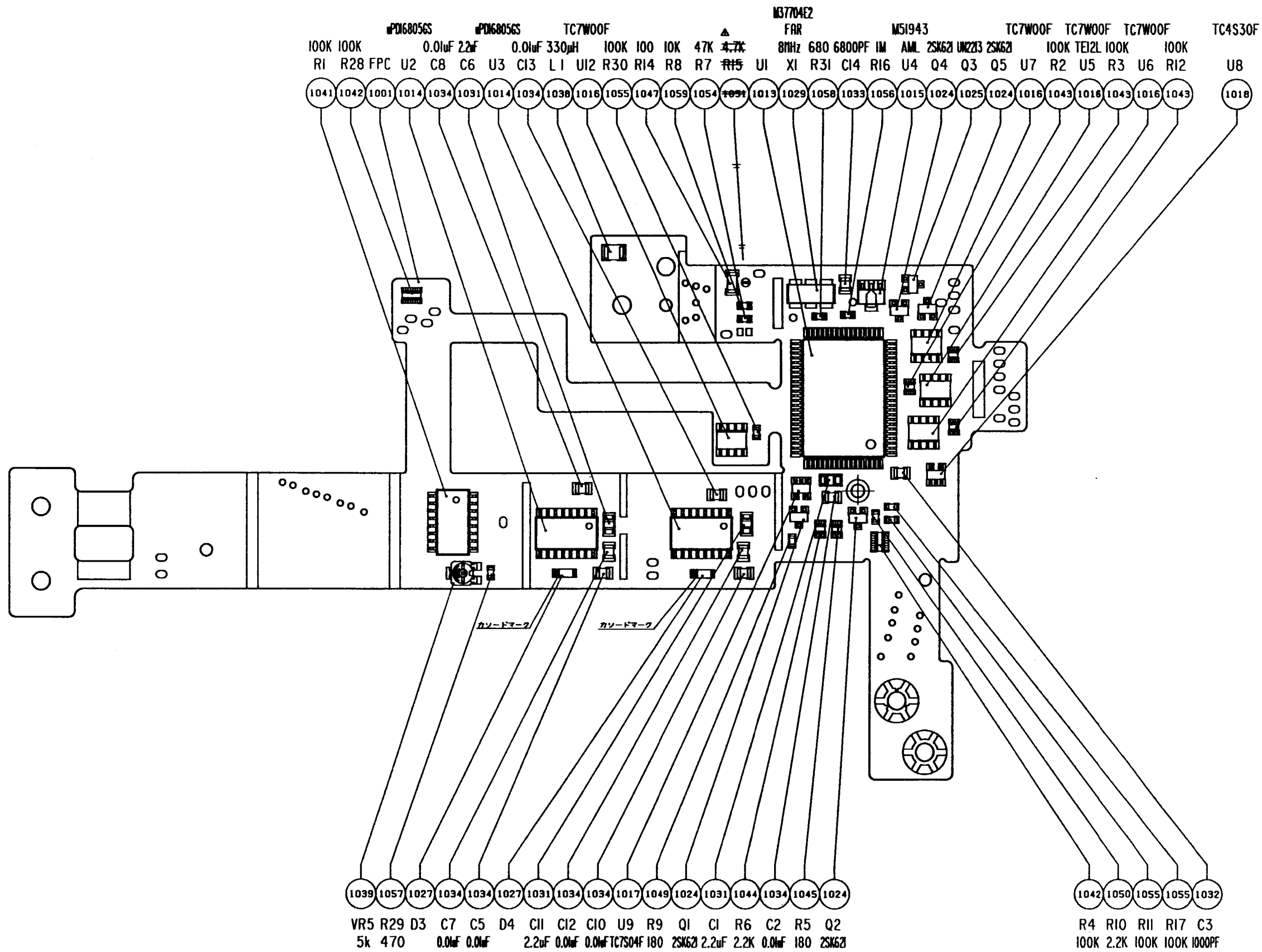

LED FPC

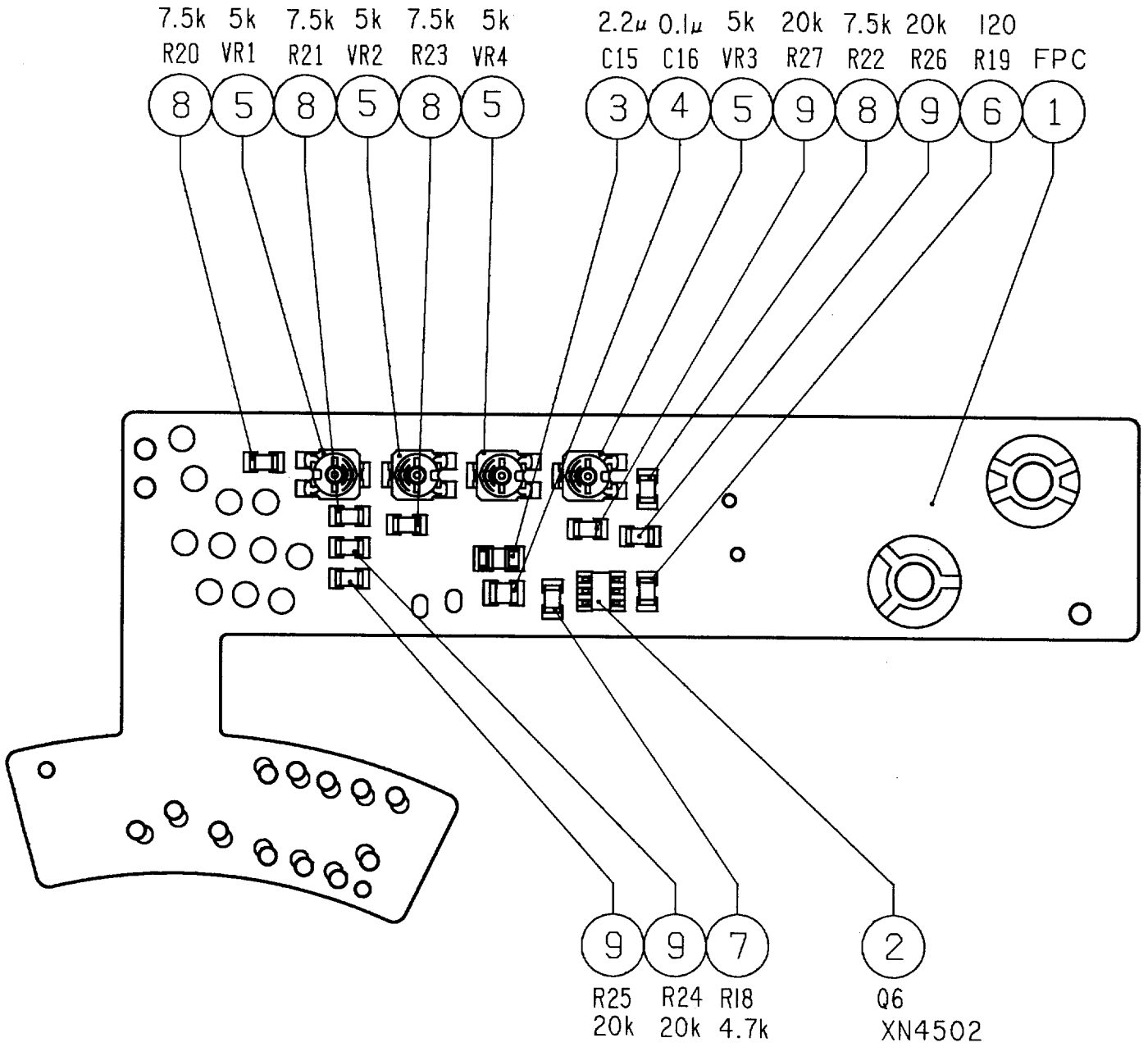

U1 CPU (M37704E2FP)

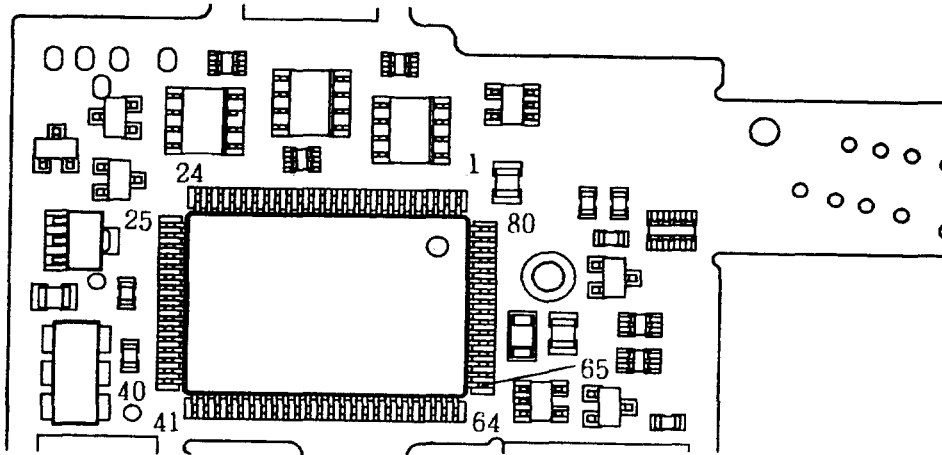

NO	名称及び内容	NO	名称及び内容
1	P70 レンズ識別 0	41	P23 距離信号 3
2	P67 MF環作動検出	42	P22 距離信号 2
3	P66 N. C.	43	P21 距離信号 1
4	P65 N. C.	44	P20 距離信号 0
5	P64 R/W	45	P17 N. C.
6	P63 インタラプタ出力	46	P16 クラッチスイッチ M
7	P62 Ex OR出力	47	P15 クラッチスイッチ A
8	P61 ガラスエンコーダB相	48	P14 フォーカスレンジ切換 1
9	P60 ガラスエンコーダA相	49	P13 フォーカスレンジ切換 0
10	P57 N. C.	50	P12 モードスイッチ 0 (A)
11	P56 クラッチモーター駆動出力1	51	P11 モードスイッチ 1 (M)
12	P55 クラッチモーター駆動許可	52	P10 フォーカスロックスイッチ
13	P54 クラッチモーター駆動出力2	53	P07 調整端子 1
14	P53 N. C.	54	P06 調整端子 2
15	P52 AFモーターPWM出力1	55	P05 オプション 1
16	P51 AFモーター駆動許可	56	P04 オプション 0
17	P50 AFモーターPWM出力0	57	P03 TC用FF出力
18	P47 N. C.	58	P02 TC用FFリセット
19	P46 N. C.	59	P01 N. C.
20	P45 N. C.	60	P00 R/W
21	P44 H接点コントロール0	61	P87 TC OUT
22	P43 E接点コントロール0	62	P86 TC IN
23	P42 H接点コントロール1	63	P85 TC CLK
24	P41 E接点コントロール1	64	P84 GND
25	P40 DC-DCコントロール	65	P83 シリアルOUT
26	BYTE GND	66	P82 シリアルIN
27	CNVss GND	67	P81 シリアルCLK
28	RESET リセット	68	P80 GND
29	Xin 発振子	69	Vdd V d d
30	Xout 発振子	70	AVcc V d d
31	E N. C.	71	Vref GND
32	Vss GND	72	AVss GND
33	P33 N. C.	73	Vss GND
34	P32 N. C.	74	P77 N. C.
35	P31 距離信号 9	75	P76 N. C.
36	P30 距離信号 8	76	P75 N. C.
37	P27 距離信号 7	77	P74 N. C.
38	P26 距離信号 6	78	P73 N. C.
39	P25 距離信号 5	79	P72 N. C.
40	P24 距離信号 4	80	P71 レンズ識別 1

U1 CPU (M37704E2FP)

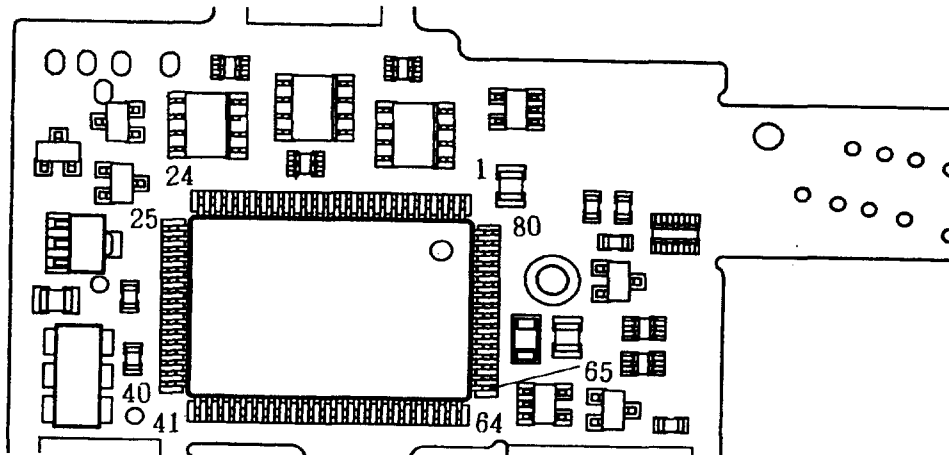

NO	Terminals	NO	Terminals
1	P70 Lens Type Signal 0	41	P23 Distance Signal 3
2	P67 MF Ring Moving Detector	42	P22 Distance Signal 2
3	P66 N. C.	43	P21 Distance Signal 1
4	P65 N. C.	44	P20 Distance Signal 0
5	P64 Read/Wright	45	P17 N. C.
6	P63 Interrupter Output	46	P16 Crutch Switch M
7	P62 Exclusive OR OUTPUT	47	P15 Crutch Switch A
8	P61 Glass Encoder Phase "B"	48	P14 Focus Range Change Switch 1
9	P60 Glass Encoder Phase "A"	49	P13 Focus Range Change Switch 0
10	P57 N. C.	50	P12 Mode Switch 0 (A)
11	P56 Crutch Motor Drive Output 1	51	P11 Mode Switch 1 (M)
12	P55 Crutch Motor Drive Enable	52	P10 Focus Lock Switch
13	P54 Crutch Motor Drive Output 2	53	P07 Adjustment Terminal 1
14	P53 N. C.	54	P06 Adjustment Terminal 0
15	P52 AF Motor PWM Output 1	55	P05 Option Terminal 1
16	P51 AF Motor Drive Enable	56	P04 Option Terminal 0
17	P50 AF Motor PWM Output 0	57	P03 FlipFlop Output for TC
18	P47 N. C.	58	P02 FlipFlop Reset for TC
19	P46 N. C.	59	P01 N. C.
20	P45 N. C.	60	P00 Read/Wright
21	P44 HTerminal Control 0	61	P87 TC OUT
22	P43 ETerminal Control 0	62	P86 TC IN
23	P42 HTerminal Control 1	63	P85 TC CLK
24	P41 HTerminal Control 1	64	P84 GND
25	P40 DC-DC Converter Control	65	P83 Serial Output
26	BYTE GND	66	P82 Serial Input
27	CNVss GND	67	P81 Serial Clock
28	RESET	68	P80 GND
29	Xin Oscillator	69	Vdd V d d
30	Xout Oscillator	70	AVcc V d d
31	E N. C.	71	Vref GND
32	Vss GND	72	AVss GND
33	P33 N. C.	73	Vss GND
34	P32 N. C.	74	P77 N. C.
35	P31 Distance Signal 9	75	P76 N. C.
36	P30 Distance Signal 8	76	P75 N. C.
37	P27 Distance Signal 7	77	P74 N. C.
38	P26 Distance Signal 6	78	P73 N. C.
39	P25 Distance Signal 5	79	P72 N. C.
40	P24 Distance Signal 4	80	P71 Lens Type Signal 1

作成承認印

配布許可印



AF-I Nikkor ED 300mm f/2.8 D IF

PARTS LIST (REVISED-1)
修理部品表 (改訂 - 1)

Nikon | NIKON CORPORATION
Tokyo, Japan

Copyright © 1995 by Nikon Corporation.
Previous edition copyright © 1992
All Rights Reserved

39	P25	Distance Signal 5	79	P72	N. C.
40	P24	Distance Signal 4	80	P71	Lens Type Signal 1

記号説明 MARKS IN THE PARTS LIST

(1) 機械標準品

下の表に示す機械標準品の部品番号は品名、種類、呼び径、長さを示しています。

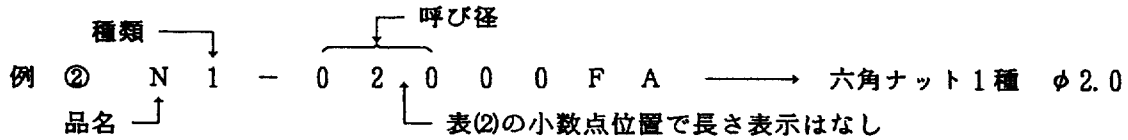
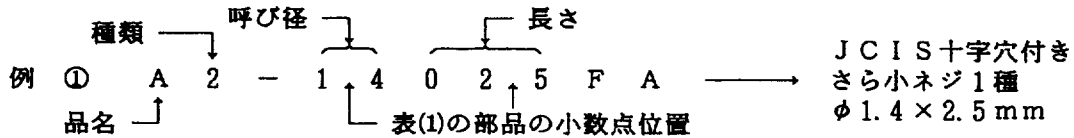

(1) Standard mechanical parts Reference Number in the Parts List

A. Screw · Pin

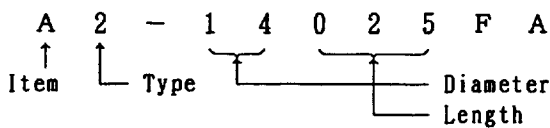

B. Nut · Washer · Snap ring



表 1

品名 Item	種類 Type	品名 Item	種類 Type				
JCIS 十字穴付き小ねじ1種 Cross-point screw 1	A	なべ Pan	1	すりわり付き止めねじ Splitted set screw	K	丸先 Round point	1
		さら Countersunk	2			とがり先 Cone point	2
		丸さら Oval	3			くぼみ先 Half point	3
JCIS 十字穴付き小ねじ3種 Cross-point screw 3	B	なべ Pan	1	六角穴付き止めねじ Hexagon socket head set screw	L	とがり先 Cone point	2
		さら Countersunk	2			くぼみ先 Half point	3
		丸さら Oval	3			平先 Normal	4
十字穴付き小ねじ Cross-point screw	C	なべ Pan	1	六角穴付きボルト Hexagon socket head bolt	M	M2, M2.6	1
		さら Countersunk	2			平行ピン Straight pin	P
		丸さら Oval	3	テーパピン Taper pin	一般用 Normal	3	
		トラス Trus	4	スプリングピン Spring cotter	軽荷重用 Light	4	
十字穴付きタップタイ タイトねじB型 Cross-point tapped screw B	F	なべ Pan	1	表 2			
		さら Countersunk	2				
十字穴付きタップタイ タイトねじB型1種 Cross-point tapped screw B1	G	なべ Pan	1	品名 Item		種類 Type	
		さら Countersunk	2	六角ナット Hexagon nut	K	1種 Type 1	1
		丸さら Oval	3	平座金 Washer	R	1種 Type 3	3
十字穴付きタップタイ タイトねじB型3種 Cross-point tapped screw B3	H	なべ Pan	1	ばね座金 Spring washer		小形丸	1
		さら Countersunk	2	E型止め環 E-snap ring	S	みがき丸	2
		丸さら Oval	3			E型 Type E	1
						G型 Type G	2
						GS型 Type GS	3

(2) 販売区分欄 The term of sale colum

記号 Mark	説明 Explanation	
○	Can be Supplied individually	単独部品として販売するもの
△	Not supplied individually but only as subassembly.	部組品でなければ販売しないもの
○△	Supplied either as part or subassembly	単独部品でも部組品でも販売するもの
×	Not considered as repair part	修理部品と考えないもの
※	Should be sent to the factory if the repair needed.	単体では交換できないので、組む場合に工場での加工が必要なもの
☒	Delivered as a product from the sales department (i.e., not supplied as repair part)	商品として販売店で販売しているもの (修理部品扱いはしない)

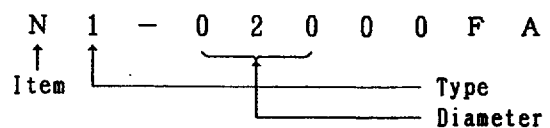
(3) 備考欄 The remarks colum

P-601M	Part number used in common	共通部品番号
(Blue ×125mm)	Lead wire (color × length)	コードの色と長さ
53F-2013 (FM-780028)	Technical information ref. number (number in parenthesis; English edition)	製品技術資料No ()内は英文
(2.1×3.8 ×0.07)	Washer (internal diameter × external diameter×thickness)	ワッシャー (内径×外径×厚さ)
(Black)	Black-finished parts	黒部品
(d=0.2)	Diameter of wire	線型=0.2
(t= 1)	Thickness	厚さ=1
Rev.	Revision	訂正
Add.	Addition	追加
Dis.	Discontinuation	廃止
OLD	Parts of the intial design	旧部品
◆	Limited part	R P 限定出庫部品
RP-9001	Repair part information No.	R P 情報 No.
R1..., D1..., W1... C1..., Q1..., P1...	Abbreviation for electronic part	電気部品記号
TA-0003	Number (TA-****) are order numbers of adhesive tape. (For the order of adhesive tape, the number 1K***-*** is not use).	接着テープ要求部番 (1K***-*** では部品要求できません。)
W-0056BE	Number (W-0056BE) are order numbers of Lead wire. (For the order of Lead wire, the number 1K***-*** is not use).	リードワイヤ要求部番 (1S***-*** では部品要求できません。)

* VERSATILE PART

* 既出部品

Apart maked with this pentagonal symblo is used commonly in the arcitecture of other products. That is called "VERSATILE PART". Note that every part, bearing new part number of eleven places, will turn into a VERSATILE PART when it is used in the design of future product.

テープ類TA設定部品一覧表

TAPES AND FILMS WITH PREFIX ALPHABETS TA Dec. 17, 1991

部品 No. Part No.	名称 Name of part	色 Color	厚さ Thickness (t=mm)	幅 Widths (mm)	長さ Length (m)	要求単位 Q'ty for a unit for ordering
TA-0001	ポリエステルフィルム Tape	透明 Transparent	0.025	10	30	1巻 1 roll
TA-0002	ポリエステルフィルム Tape	透明 Transparent	0.025	20	30	1巻 1 roll
TA-0003	両面接着テープ Both sided adhesive tape	白 White	0.16	10	2	1巻 1 roll
TA-0004	両面接着テープ Both sided adhesive tape	黒 Black	0.14	12	50	1巻 1 roll
TA-0005	ポリエステルフィルム Tape	黄 Yellow	0.06	19	66	1巻 1 roll
TA-0006S	アセテートクロス (シート) Tape (200x120/sheet)	黒 Black	0.23	6	200 (mm)	1set (20pcs)
TA-0007	銅箔導電性 Tape, copper foil	銅箔 Copper foil	0.11	4	6	1巻 1 roll
TA-0008	ポリエステルフィルム Tape	透明 Transparent	0.055	30	30	1巻 1 roll
TA-0009	カプトンフィルム Tape	琥珀 Amber	0.07	6	30	1巻 1 roll
TA-0010	両面接着テープ Both sided adhesive tape	乳白色 Opal	0.16	15	36	1巻 1 roll
TA-0011	ポリエステルフィルム Tape	黒 Black	0.06	10	30	1巻 1 roll
TA-0012	ポリエステルフィルム Tape	透明 Transparent	0.025	6	30	1巻 1 roll
TA-0013	アセテートクロス (シート) Tape (200x120/sheet)	黒 Black	0.23	20	200 (mm)	1set (20pcs)

収縮チューブ一覧表

Thermal construction tube list

Dec. 17, 1991

部品 No. Part No.	名 称 Name of part	直 径 Diameter (φ)	長 さ Length (m)	備 考 Remarks
TU-0001	収縮チューブ Thermal construction tube	1.0 mm	1	RP-8925
TU-0002	収縮チューブ Thermal construction tube	2.0 mm	1	RP-8925
TU-0003	収縮チューブ Thermal construction tube	3.0 mm	1	RP-8925
TU-0004	収縮チューブ Thermal construction tube	4.0 mm	1	RP-8925

A

B

C

D

AF-I ED 300/2.8D IF

JAA32651-R. 3311. B

(1)
1B100-635-1

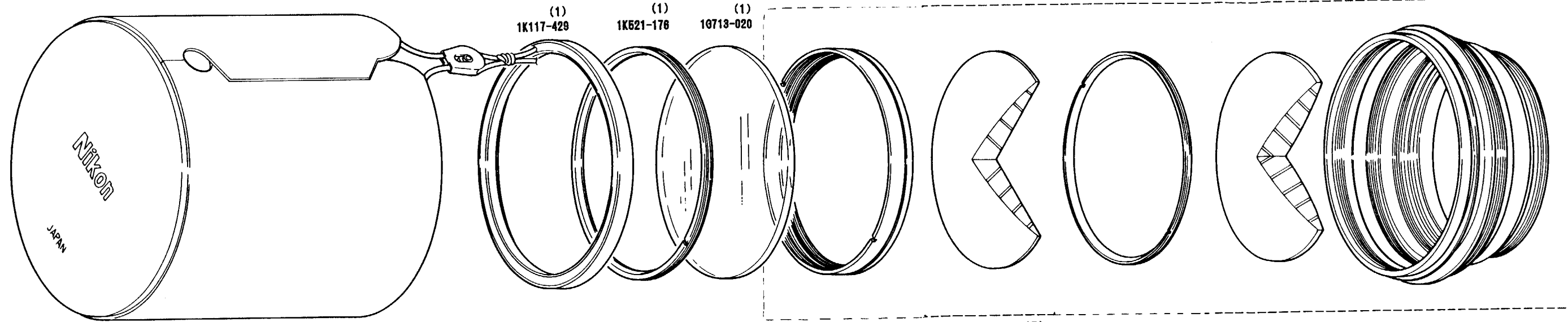

1

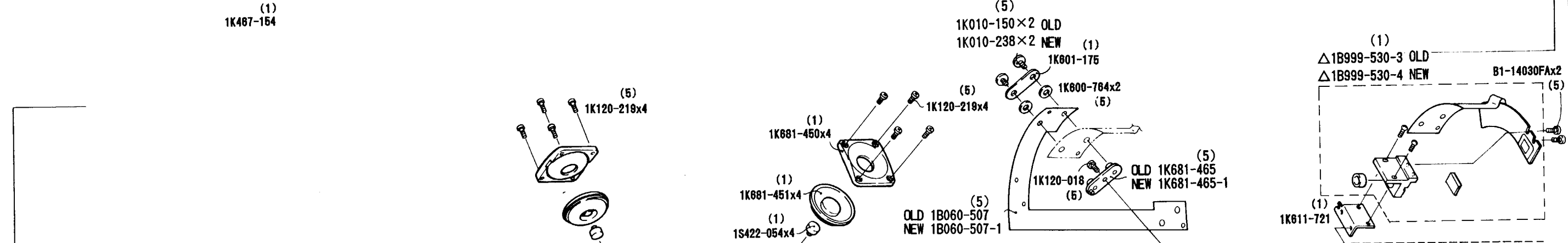

2

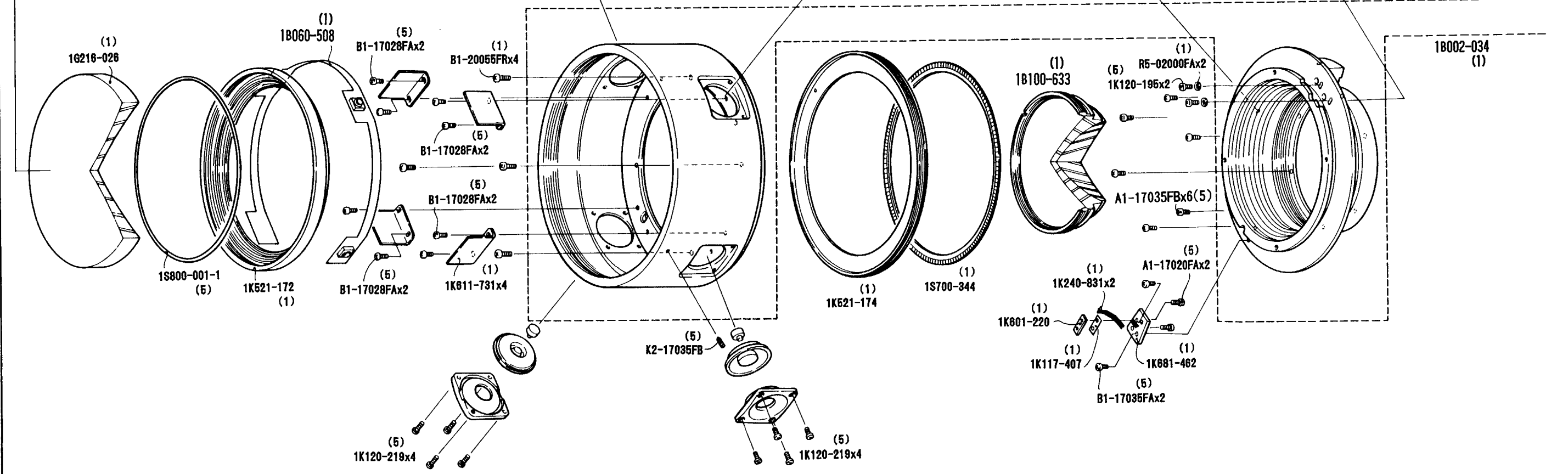

3

Fig. 1

A

B

AF-I ED 300/2.8D IF

JAA32651-R.3311.B

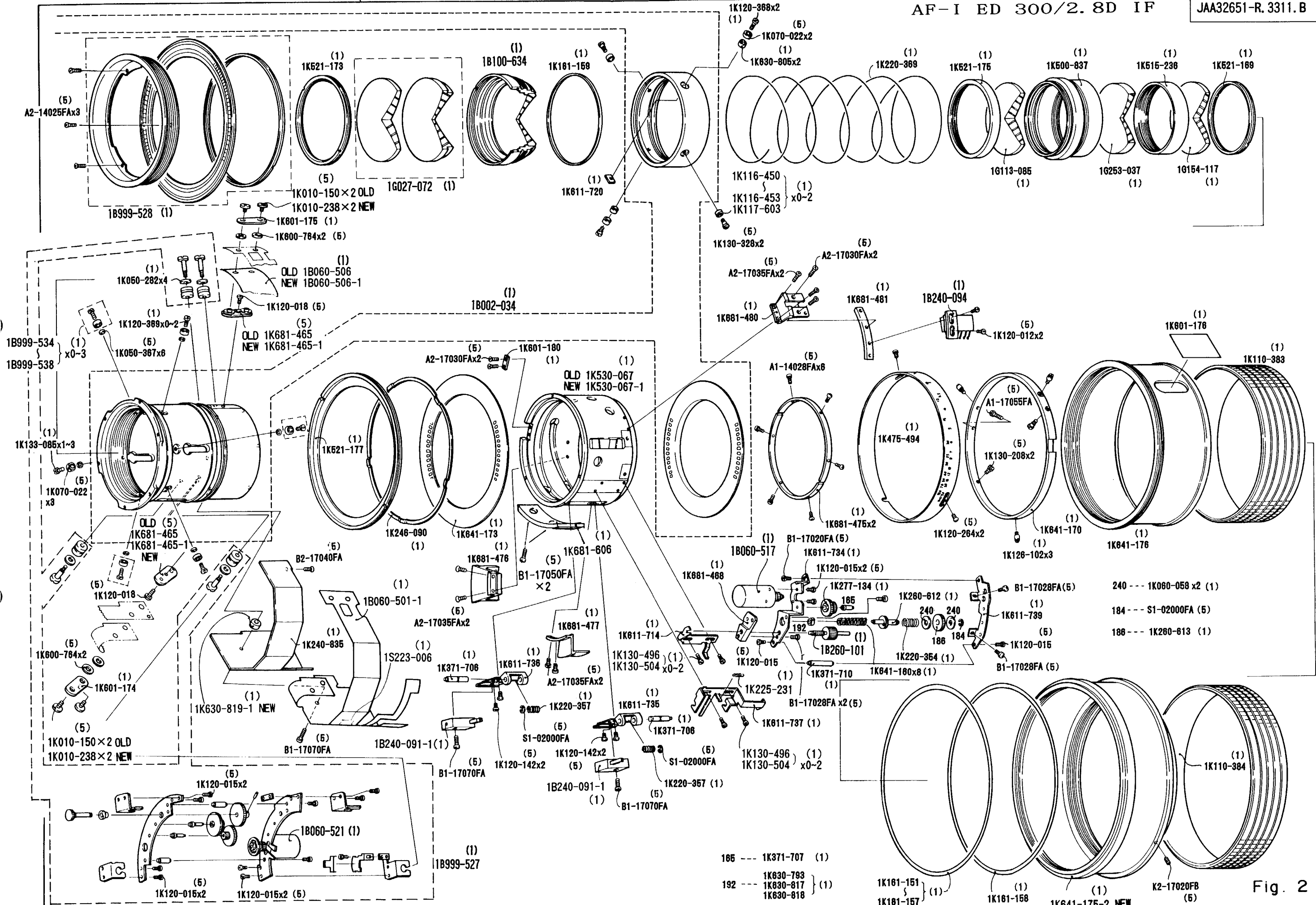

1

2

3

Fig. 2

A

B

C

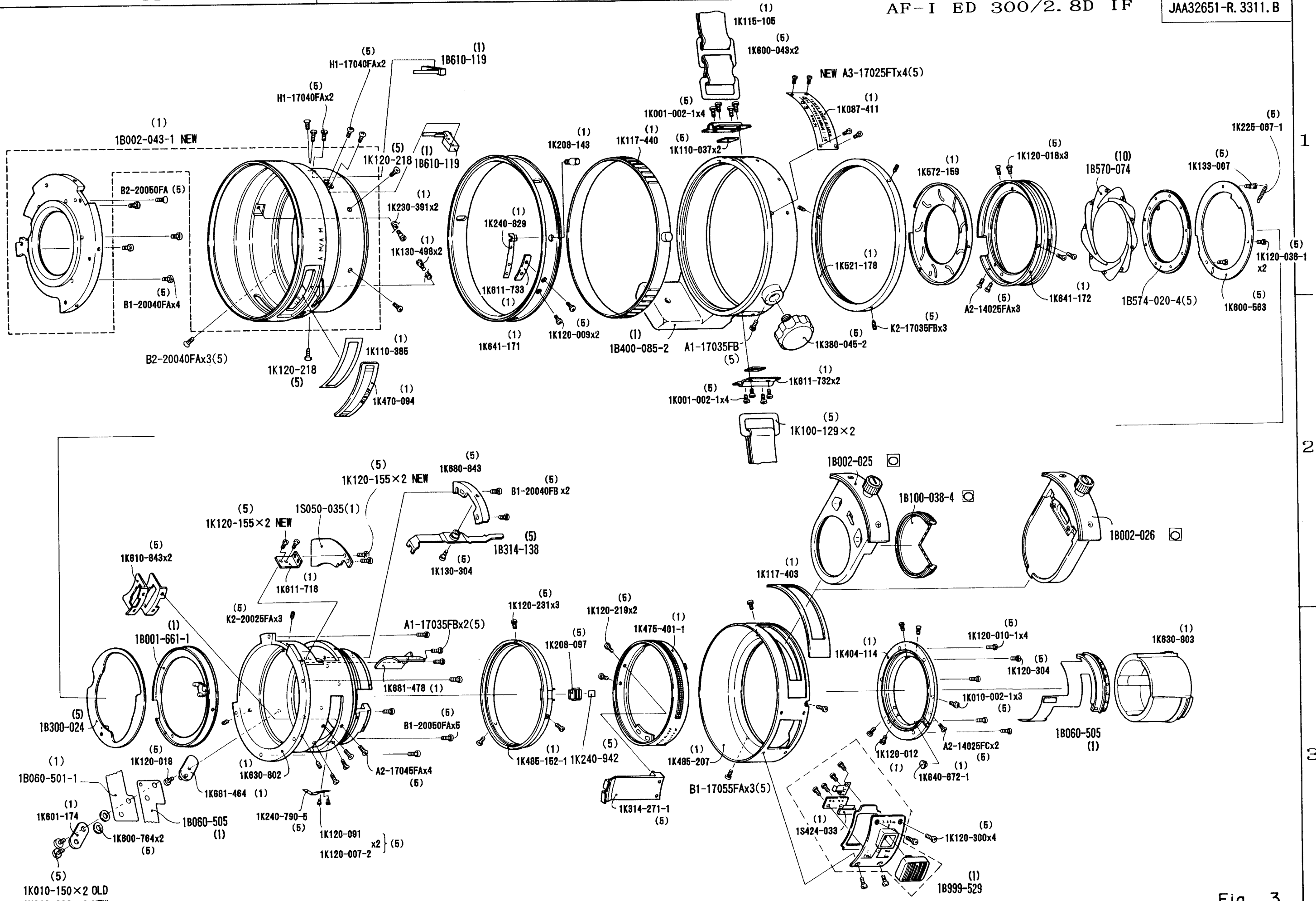

Fig. 3

部品表 Parts List

AF-I ED 300/2.8D IF

JAA32651-R. 3311. B

部品番号 Part No.	補助番号 Ckt No.	名称 Name	1台分 個数 Pcs. Per Unit	部組品番号 Assembly	参照 図番 Fig. No.	販売区分 Term of Delivery	備考 Remarks	要求単位 Q'ty per order
*1K001-002-1 (1K001-002)	139	Screw	8		3-C2 3-C1	○	A1-26040FX	5
*1K010-002-1	158	Screw	3		3-D3	○		5
*1K010-150	289	Screw	8		1-C2 2-A1	○		5
*1K010-238		Screw	8		2-A3 3-A3	○△	RP-93C2	5
*1K050-282	329	Washer	4	1B999-527	2-A1	○△	JAA51951	1
*1K050-367	242	Washer	6		2-A2	○		5
*1K060-058	240	Washer	2		2-C3 2-D2	○	JAA51951	1
*1K070-022	74	軸受け Shaft holder	8		2-A2 2-C1	○		5
1K087-411	269	銘板 Name plate	1		3-C1	○		1
1K100-129	135	吊り環 Eyelet	2		3-C2	○		5
*1K110-037	128	ゴム板 Rubber plate	2		3-C1	○		5
1K110-383	37	ゴムリング Rubber ring	1		2-D2	○		1
1K110-384	176	ゴムリング Rubber ring	1		2-D3	○		1
*1K110-385	106	Tape	1		3-B2	○	JAA51951	1
*1K115-105	130	Belt	1		3-C1	○		1

部品表 Parts List

JAA32651-R. 3311. B

部品番号 Part No.	補助番号 Ckt No.	名称 Name	1台分 個数 Pcs. Per Unit	部組品番号 Assembly	参照 図番 Fig. No.	販売区分 Term of Delivery	備考 Remarks	要求単位 Qty per order
*1K116-450	243	ガイド環 Guide ring	0-2		2-C1	○		5
*1K116-451		ガイド環 Guide ring	0-2		2-C1	○		5
*1K116-452		ガイド環 Guide ring	0-2		2-C1	○		5
*1K116-453		ガイド環 Guide ring	0-2		2-C1	○		5
*1K117-228	327	Tape	1			×	TA-0006S	
*1K117-403	59	Tape	1		3-C2	○	JAA51951	1
*1K117-407	203	マイラーシート Sheet	1		1-C3	○	JAA51951	1
1K117-413	313	Tape	2			×	TA-0004	
1K117-429	54	保護ゴム Cover ring	1		1-B1	○		1
1K117-440	310	ゴムリング Rubber ring	1		3-B1	○		1
1K117-603	243	ガイド環 Guide ring	0-2		2-C1	○	RP-93C2	5
*1K120-007-2	125	Screw	0-2		3-B3	○		5
*1K120-009	291	Screw	2		3-B2	○		5
*1K120-010-1 (1K120-010)	127	Screw	4		3-D3	○		5
*1K120-012	129	Screw	3		2-C2 3-C3	○		1
*1K120-015	281	Screw	13	1B999-527	2-A3, C2 2-C3 2-D3	○△		5
*1K120-018	126	Screw	9		1-C2 2-A2 3-D1, A3	○	RP-93C1	5

部品表 Parts List

JAA32651-R. 3311. B

部品番号 Part No.	補助番号 Ckt No.	名称 Name	1台分 個数 Pcs. Per Unit	部組品番号 Assembly	参照 図番 Fig. No.	販売区分 Term of Delivery	備考 Remarks	要求単位 Q'ty per order
*1K120-036-1 (1K120-036)	120	Screw	2		3-D1	○		5
*1K120-091	125	Screw	0-2		3-B3	○		5
*1K120-142	284	Screw	4		2-B3	○		5
*1K120-155	278	Screw	4		3-A2 3-B2	○	RP-9530	5
*1K120-195	282	Screw	2		1-C2	○		5
1K120-218	253		2		3-A2 3-B1	○		5
*1K120-219	95	Screw	18		1-B3 1-B2 3-B2	○		5
*1K120-231	260	Screw	3		3-B2	○		5
*1K120-264	255	Screw	2		2-C2	○		5
*1K120-300	298	Screw	4		3-C3	○		5
*1K120-304	145	Screw	1		3-D3	○		5
1K120-368	292	Screw	2		2-C1	○		1
*1K120-369	308	Screw	4		2-A2	○	JAA51951	1
*1K126-102	77	Screw	3		2-D2	○	JAA51951	1
*1K130-208	195	Screw	2		2-C2	○		5
*1K130-304	124	Screw	1		3-B2	○		5
*1K130-328	244	Screw	2		2-C1	○		5

部品表 Parts List

JAA32651-R. 3311. B

部品番号 Part No.	補助番号 Ckt No.	名称 Name	1台分 個数 Pcs. Per Unit	部組品番号 Assembly	参照 図番 Fig. No.	販売区分 Term of Delivery	備考 Remarks	要求単位 Q'ty per order
*1K130-496	183	Screw	0-4		2-B3 2-C3	○	JAA51951	1
1K130-498	248	Screw	2		3-B2	○		1
*1K130-504	183	Screw	0-4		2-B3 2-C3	○	JAA51951	1
*1K133-007	99	Screw	1		3-D1	○		5
*1K133-085	239	Screw	2		2-A2	○	JAA51951	1
1K161-151	177	Washer t=0.2	0-1		2-C3	○		1
1K161-152		Washer t=0.1	0-1		2-C3	○		1
1K161-153		Washer t=0.09	0-1		2-C3	○		1
1K161-154		Washer t=0.08	0-1		2-C3	○		1
1K161-155		Washer t=0.07	0-1		2-C3	○		1
1K161-156		Washer t=0.06	0-1		2-C3	○		1
1K161-157		Washer t=0.05	0-1		2-C3	○		1
1K161-158	179	Washer	1		2-C3	○		1
1K161-159	305	Washer	1		2-B1	○		1
*1K208-097	172	ロック釦 Lock button	1		3-B3	○		5
*1K208-143	85	マクロ釦 Macro button	1		2-B1	○	JAA51951	1

部品表 Parts List

JAA32651-R. 3311. B

部品番号 Part No.	補助番号 Ckt No.	名称 Name	1台分 個数 Pcs. Per Unit	部組品番号 Assembly	参照 図番 Fig. No.	販売区分 Term of Delivery	備考 Remarks	要求単位 Q'ty per order
*1K220-354-1 (1K220-354)	182	Spring	1		2-C3	○	JAA51951	1
1K220-357	187	Spring	2		2-B3	○		1
1K220-369-1 (1K220-369)	320	Spring	1		2-C1	○		1
*1K225-067-1 (1K225-067)	96	Spring	1		3-D1	○		5
1K225-231-1	188	Spring	1		2-C3	○	93F-2032 RP-	1
1K230-391	247	Spring	2		3-B2	○		1
*1K240-942 (1K240-563)	173	EE ロックバネ EE lock spring	1			○		5
*1K240-790	36	クリックバネ Click spring	1		3-A3	○		5
*1K240-829-1 (1K240-829)	87	曲げ板 Bent plate	1		2-B1	○	JAA51951	1
*1K240-831	201	ブラシ Brush	2		1-C3	○	JAA51951	1
1K240-835	98	板バネ Leaf spring	1		2-A3	○		1
1K240-942		バネ Spring	1		3-B3	○		5
1K246-090	119	板バネ Leaf spring	1		2-B2	○		1
*1K260-612	185	歯車 Gear	1		2-C2	○	JAA51951	1
*1K260-613	186	歯車 Gear	1		2-D3 2-C3	○	JAA51951	1
*1K277-134	164	歯車 Gear	1		2-C2	○	JAA51951	1

部品表 Parts List

JAA32651-R. 3311. B

部品番号 Part No.	補助番号 Ckt No.	名称 Name	1台分 個数 Pcs. Per Unit	部組品番号 Assembly	参照 図番 Fig. No.	販売区分 Term of Delivery	備考 Remarks	要求単位 Qty per order
*1K314-271-1 (1K314-271)	199	連動レバー Lever	1		3-B3	○		5
*1K371-706	102	軸 Axle	2		2-B3	○	JAA51951	1
*1K371-707	165	軸 Axle	1		2-C2 2-C3	○	JAA51951	1
*1K371-710	232	軸 Axle	1		2-C3	○	JAA51951	1
*1K380-045-3 (1K380-045-1)	70	クランプネジ Clamp screw	1		3-C2	○		5
1K404-114-2 (1K404-114)	30	バヨネット Bayonet mount	1		3-C3	○		1
1K467-154	273	キャップ Cap	1		1-A1	○		1
1K470-094	57	アクリル窓 Acryle plate	1		3-B2	○		1
*1K475-401-1 (1K475-401)	28	絞り環 Diaphragm	1		3-C3	○		1
1K475-494	26	距離環 Focus ring	1		2-C2	○		1
*1K485-152-1 (1K485-152)	105	指標環 Index ring	1		3-B3	○		1
1K485-207	58	指標環 Index ring	1		3-C3	○		1
1K500-837-1 (1K500-837)	50	G12 レンズ室 G12 lens housing	1		2-D1	○		1
1K515-236	60	G11.G12 分離環 G11.G12 space ring	1		2-D1	○		1

部品表 Parts List

JAA32651-R. 3311. B

部品番号 Part No.	補助番号 Ckt No.	名称 Name	1台分 個数 Pcs. Per Unit	部組品番号 Assembly	参照 図番 Fig. No.	販売区分 Term of Delivery	備考 Remarks	要求単位 Q'ty per order
1K521-169	42	G12 押さえ環 G12 retaining ring	1		2-D1	○		1
1K521-170	44	G2 押さえ環 G2 retaining ring	1			△	RP-9287	1
1K521-171	45	G3 押さえ環 G3 retaining ring	1			△	RP-9287	1
1K521-172	46	G4 押さえ環 G4 retaining ring	1		1-A3	○		1
1K521-173	48	G7 押さえ環 G7 retaining ring	1		2-A1	○		1
1K521-174	61	押さえ環 Retaining ring	1		1-C3	○		1
1K521-175	62	G10 押さえ環 G10 retaining ring	1		2-C1	○		1
1K521-176	80	G7 押さえ環 G7 retaining ring	1		1-B1	○		1
1K521-177	118	押さえ環 Retaining ring	1		2-A1	○		1
1K521-178	175	押さえ環 Retaining ring	1		3-C1	○		1
1K530-067	24	リード 溝環	1		2-B2	○	93F-1013 RP-9363	1
1K530-067-1		Inner tube						
1K572-159	34	羽根基板 Blade mount plate	1		3-C1	○		1
*1K600-043	131	Plate	2		3-C3	○		5
*1K600-563	79	Plate	1		3-D1	○		5
*1K600-764	290	圧接ゴム Rubber	8		1-C2 2-A1. A3 3-A3	○		5
*1K601-174	267	Plate	2		2-A3 3-A3	○	JAA51951	1

部品表 Parts List

JAA32651-R. 3311. B

部品番号 Part No.	補助番号 Ckt No.	名称 Name	1台分 個数 Pcs. Per Unit	部組品番号 Assembly	参照 図番 Fig. No.	販売区分 Term of Delivery	備考 Remarks	要求単位 Q'ty per order
*1K601-175	268	Plate	2		1-C2 2-A1	○	JAA51951	1
*1K601-176	319	Plate	1		2-D2	○	JAA51951	1
1K601-180	150	Plate	1		2-B2	○		1
*1K601-220	204	Plate	1		1-C3	○	JAA51951	1
*1K610-843	83	曲げ板 Bent plate	2		3-A2	○		5
*1K611-714	107	Lever	1		2-B3	○	JAA51951	1
1K611-718	171	曲げ板 Bent plate	1		3-A2	○		1
*1K611-720	189	曲げ板 Bent plate	1		2-B1	○	JAA51951	1
1K611-721	207	曲げ板 Bent plate	1		1-D2	○		1
*1K611-731	51	曲げ板 Bent plate	4		1-B3	○	JAA51951	1
*1K611-732	75	曲げ板 Bent plate	2		3-C2	○	JAA51951	1
1K611-733	88	押さえ板 Retaining plate	1		2-B1	○		1
1K611-734	140	曲げ板 Bent plate	1		2-C2	○		1
1K611-735	141	軸受け Shaft holder	1		2-B3	○		1
1K611-736	170	軸受け Shaft holder	1		2-B3	○		1
1K611-737	191	クラッチ 連動板 Clutch plate	1		2-C3	○		1

部品表 Parts List

JAA32651-R. 3311. B

部品番号 Part No.	補助番号 Ckt No.	名称 Name	1台分 個数 Pcs. Per Unit	部組品番号 Assembly	参照 図番 Fig. No.	販売区分 Term of Delivery	備考 Remarks	要求単位 Q'ty per order
1K611-739	209	曲げ板 Bent plate	1		2-C3	○		1
*1K630-793	192	Bush	0-1		2-C3	○	JAA51951	1
1K630-802-1 (1K630-802)	29	後部本体 Rear barrel	1		3-A3	○		1
1K630-803	39	丸筒 Tube	1		3-D3	○		1
1K630-805	293	丸筒 Tube	2		2-C1	○		1
*1K630-817	192	Bush	0-1		2-C3	○	JAA51951	1
*1K630-818		Bush	0-1		2-C3	○	JAA51951	1
1K630-819-1	137	Bush	1		2-A3	○	93F-2032 RP-9530	1
*1K640-672-1 (1K640-672)	178	丸環 Ring	1		3-C3	○		1
*1K641-160	198	Bush	8		2-C3	○	JAA51951	1
1K641-170-1 (1K641-170)	66	丸環 Ring	1		2-D2	○		1
1K641-171	67	丸環 Ring	1		3-B2	○		1
1K641-172-1 (1K641-172)	78	丸環 Ring	1		3-D1	○		1
1K641-173-1 (1K641-173)	111	丸環 Ring	1		2-B2	○		1
1K641-175-2	167	丸筒 Tube	1		2-D3	○	93F-1020 RP-9530	1
1K641-176-1 (1K641-176)	168	丸筒 Tube	1		2-D2	○		1

部品表 Parts List

JAA32651-R. 3311. B

部品番号 Part No.	補助番号 Ckt No.	名称 Name	1台分 個数 Pcs. Per Unit	部組品番号 Assembly	参照 図番 Fig. No.	販売区分 Term of Delivery	備考 Remarks	要求単位 Q'ty per order
*1K680-843	100	Block	1		3-B2	○		5
*1K681-450	63	Block	4		1-C2	○	JAA51951	1
*1K681-451	64	Block	4		1-C2	○	JAA51951	1
*1K681-462	205	Block	1		1-C3	○	JAA51951	1
*1K681-464	262	Block	2		2-A2	○	JAA51951	1
*1K681-464-1				3-A3	RP-93C2			
*1K681-465	263	Block	2		1-C2	○	JAA51951	1
*1K681-465-1				2-A2	RP-93C2			
*1K681-468	254	Block	1		2-C2	○	JAA51951	1
1K681-475	84	Block	2		2-C2	○		1
1K681-476	94	Block	1		2-B2	○		1
1K681-477	97	Block	1		2-B3	○		1
1K681-478	115	Block	1		3-B3	○		1
1K681-480	225	Block	1		2-C2	○		1
1K681-481	226	Block	1		2-C2	○		1
1K681-606	40	Block	1		2-B2	○	93F-1013 RP-9363	1

部品表 Parts List

JAA32651-R. 3311. B

部品番号 Part No.	補助番号 Ckt No.	名称 Name	1台分 個数 Pcs. Per Unit	部組品番号 Assembly	参照 図番 Fig. No.	販売区分 Term of Delivery	備考 Remarks	要求単位 Qty per order
1G113-085	G10	G10 レンズ G10 lens element	1		2-D1	○		1
1G154-117	G12	G12 レンズ G12 lens element	1		2-D1	○		1
1G216-026	G4	G4 レンズ G4 lens element	1		1-A2	※		1
1G253-037	G11	G11 レンズ G11 lens element	1		2-D1	○		1
1G713-020-1 (1G713-020)	G1	G1 レンズ G1 lens element	1		1-B1	○		1

※印は修理にて調整不可の為、工場送りとなる部品を示します。
 An item with a mark ※ is not available as repair parts since
 the relevant repair involves adjustment at our factory.

部品表 Parts List

JAA32651-R. 3311. B

部品番号 Part No.	補助番号 Ckt No.	名称 Name	1台分 個数 Pcs. Per Unit	部組品番号 Assembly	参照 図番 Fig. No.	販売区分 Term of Delivery	備考 Remarks	要求単位 Q'ty per order
1S050-035	1021	DC/DC コンバーター DC/DC converter	1		3-B2	○		1
*1S223-006		MD-IC	1		2-B3	○△	JAA51951 93F-2018 RP-9530	1
*1S422-054	157	スイッチ Swicth	4		1-B2	○	JAA51951	1
*1S424-033	156	スライドスイッチ Slide swicth	1	1B999-529	3-C3	○△	JAA51951	1
1S700-344	68	基板 Plate	1		1-C3	○		1
*1S800-001-1 (1S800-001)	104	Wire	1		1-A3	○		5
1S811-512	1061	Wire	1		Page E1	×	W-0080BE	
1S811-513	1062	Wire	1		Page E1	×	W-0080OR	
1S811-514	1063	Wire	1		Page E1	×	W-0080OR	
1S811-515	1064	Wire	1		Page E1	×	W-0080BE	
1S811-516	1065	Wire	1		Page E1	×	W-0080PU	
1S811-517	1066	Wire	1		Page E1	×	W-0080WH	
1S811-518	1067	Wire	1		Page E1	×	W-0080OR	
1S811-519	1068	Wire	1		Page E1	×	W-0080WH	
1S811-520	1069	Wire	1		Page E1	×	W-0080PU	
1S811-521	1070	Wire	1		Page E1	×	W-0080OR	
1S811-522	1071	Wire	1		Page E1	×	W-0080BE	

部品表 Parts List

JAA32651-R. 3311. B

部品番号 Part No.	補助番号 Ckt No.	名称 Name	1台分 個数 Pcs. Per Unit	部組品番号 Assembly	参照 図番 Fig. No.	販売区分 Term of Delivery	備考 Remarks	要求単位 Q'ty per order
1S811-523	1072	Wire	1		Page E1	×	W-0056BN	
1S811-524	1073	Wire	1		Page E1	×	W-0056PU	
1S811-525	1074	Wire	1		Page E1	×	W-0056BK	
1S811-529	1078	Wire	1		Page E1	×	W-0056BK	
1S811-530	1079	Wire	1		Page E1	×	W-0056PU	
1S811-531	1080	Wire	1		Page E1	×	W-0056BN	
1S811-532	1081	Wire	1		Page E1	×	W-0056YE	
1S811-533	1082	Wire	1		Page E1	×	W-0056GY	
1S811-534	1083	Wire	1		Page E1	×	W-0056YE	
1S811-535	1084	Wire	1		Page E1	×	W-0056BK	
1S811-536	1085	Wire	1		Page E1	×	W-0056PU	
1S811-541	1088	Wire	1		Page E1	×	W-0056BK	

部品表 Parts List

JAA32651-R. 3311. B

部品番号 Part No.	補助番号 Ckt No.	名称 Name	1台分 個数 Pcs. Per Unit	部組品番号 Assembly	参照 図番 Fig. No.	販売区分 Term of Delivery	備考 Remarks	要求単位 Q'ty per order
A1-14028FA	279	Screw	6		2-C2	○		5
A1-17020FA	208	Screw	2		1-D3	○		5
1K120-155	278	Screw	4		3-	○	RP-9530	5
A3-17025FT	297	Screw	4		3-C1	○	RP-9530	5
A1-17035FB	116	Screw	9		1-C3 3-C2 3-B3	○		5
A1-17055FA	122	Screw	1		2-C2	○		5
A2-14025FA	148	Screw	6		2-A1 3-D1	○		5
A2-14025FC	261	Screw	2		3-C3	○		5
A2-17030FA	222	Screw	4		2-C1 2-B2	○		5
A2-17035FA	228	Screw	6		2-C1 2-B3	○		5
A2-17045FA	258	Screw	4		3-B3	○		5
B1-14030FA	230	Screw	4		1-D2	○		5
B1-17020FA	108	Screw	1		2-C2	○		5
B1-17028FA	113	Screw	12		1-A2, A3 1-B3 2-C3, D3	○		5
B1-17035FA	288	Screw	4		1-C3	○		5
B1-17055FT	259	Screw	3		3-C3	○		5
B1-17070FA	216	Screw	3		2-A3 2-B3	○		5
B1-20040FA	280	Screw	4		3-A1	○		5



部品表 Parts List

JAA32651-R. 3311. B

部品番号 Part No.	補助番号 Ckt No.	名称 Name	1台分 個数 Pcs. Per Unit	部組品番号 Assembly	参照 図番 Fig. No.	販売区分 Term of Delivery	備考 Remarks	要求単位 Q'ty per order
B1-17050FA	22	Screw	2		2-B2	○	93F-1013 RP-9363	5
B1-20040FB	152	Screw	2		3-B2	○		5
B1-20050FA	257	Screw	5		3-B3	○		5
B1-20055FR	159	Screw	4		1-B2	○		1
B2-17040FA	295	Screw	1		2-A2	○		5
B2-20040FA	256	Screw	3		3-A2	○	RP-93C1	5
B2-20050FA	241	Screw	1		3-A1	○		5
H1-17040FA	266	Screw	4		3-B1 3-A1	○		5
K2-17020FB	277	Screw	1		2-D3	○		5
K2-17035FB	252	Screw	4		1-B3 3-C2	○		5
K2-20025FA	294	Screw	3		3-A2	○		5
R5-02000FA	138	Washer	2		1-D2	○	JAA51951	1
S1-02000FA	184	E-ring	4	1B999-527	2-B3 2-D3 2-C3	○△		5

部組品表 Assembly List

JAA32651-R. 3311. B

部組番号 Part No.	補助番号 Ckt No.	名称 Name	1台分 個数 Pcs. Per Unit	構成部品番号 Constituent Parts	参照 図番 Fig. No.	備考 Remarks	要求単位 Qty per order
*1B001-661-1 (1B001-661)	B82	レバー組 Lever unit	1	1B310-009-1 1K370-028-3 1K640-671	3-A3		1
*1B002-025	B86	フィルターホルダー Filter holder	1	1B002-027 1K001-003-1 x 2 1K220-021-1 1K480-001-1 1K680-024 1K681-452 1K681-453 P3-10050SX	3-C2		
*1B002-026	B136	ゼラチンフィルターホルダー Gelatin filter holder	1	1B002-027 1K001-003-1 x 2 1K117-465 1K220-021-1 1K233-008-2 1K480-001-1 1K611-751 1K625-059 1K680-024 1K681-454 1K681-482 A2-20040FT x 2 P3-10050SX	3-D2		
1B002-034-2 (1B002-034)	B35	丸環組 Ring unit	1	1K260-620 1K630-804-1 1K641-167 1K641-168-1 1K641-169	1-D2		1
1B002-043-1	B27	丸筒組 Tube unit	1	1K302-066-1 1K641-174	3-A1	RP-93C1 RP-9513	1
*1B060-501-1	B1001	メインFPC組 Main FPC unit	1	1K117-525 x 5 1K117-526 x 2 1S020-085-1	2-B2 3-A3	JAA51951 RP-9513	1
1B060-505-2 (1B060-505)	B1003	接点FPC組 Connecting FPC unit	1	1K116-626 1K117-485 1K240-469-1 x 10 1K611-827-2 1K681-466 1K681-539 1S705-232	3-A3	RP-93C2	1
1B060-505-4					3-D3		
1B060-506 1B060-506-1	B1004	エンコーダーFPC組 FPC unit	1	1K117-462 1S705-233	2-A1	RP-93C2	1

部組品表 Assembly List

JAA32651-R. 3311. B

部組番号 Part No.	補助番号 Ckt No.	名称 Name	1台分 個数 Pcs. Per Unit	構成部品番号 Constituent Parts	参照 図番 Fig. No.	備考 Remarks	要求単位 Qty per order
1B060-507	B1005	中継FPC 組	1	1K117-413 x 2 1K117-525 1S705-234	1-C2	RP-93C2 製技資93F-1010	1
1B060-507-1		Relay FPC unit					
*1B060-508	B1006	フォーカスロックFPC 組 Focus lock FPC unit	1	1K117-525 X 4 1S020-087	1-A2	JAA51951	1
1B060-517	B220	モーター Moter	1		2-C2		1
1B060-521	B210	モーター 組 Moter unit	1	1B060-498 1K120-015 x 2 1K601-183 1K641-181-1	2-A3		1
*1B100-038	Z93	フィルター Filter	1	1G610-002-1 1K160-056-1 1K500-082-2	3-C2	○	
1B100-633	Z49	G5.G6 レンズ室 組 G5.G6 lens housing unit	1	1G152-062-1 1G252-037 1K500-836	1-C2		1
1B100-634	Z25	G9レンズ室 組 G9 lens housing unit	1	1G212-017 1K510-404	2-B2		1
1B100-635-1	Z43	G2.G3 レンズ室 組 G2.G3 lens housing unit	1	1G115-051 1K521-171 1G156-052 1K500-835 1K521-170	1-D1	RP-9287 ※	1
*1B240-091-1	B109	ブラシ 組 Brush unit	2	1K240-830-1 1K611-711-1	2-B3	JAA51951 93F-2032 RP-9517	1
1B240-094	B71	板バネ 組 Leaf spring unit	1	1K240-826 x 2 1K240-827 x 2 1K240-828 1K681-474	2-C2		1
*1B260-101	B121	歯車 組 Gear unit	1	1K371-759	2-C3	JAA51951	1
*1B300-024	B21	カム 組 Cam unit	1	1K300-071 1K370-117	3-A3		5
*1B314-138	B23	シーソーレバー 組 Lever fixing	1	1K314-270 1K340-133	3-B2		5

※印は修理にて調整不可の為、工場送りとなる部品を示します。
An item with a mark ※ is not available as repair parts since
the relevant repair involves adjustment at our factory.

部組品表 Assembly List

JAA32651-R. 3311. B

部組番号 Part No.	補助番号 Ckt No.	名称 Name	1台分 個数 Pcs. Per Unit	構成部品番号 Constituent Parts	参照 図番 Fig. No.	備考 Remarks	要求単位 Qty per order
1B400-085-2	B69	三脚座 Tripod attaching	1	1K400-342 U2-16310SX	3-C2	RP-93C1 RP-9517	1
*1B570-074	B31	羽根 組 Blade unit	9	1K370-111-1 x 2 1K570-074	3-D1		10
*1B574-020-4	B33	羽根基板 組 Blade actuating unit	1	1K042-001 1K370-114 1K574-114 1K600-045-1	3-D1		5
1B610-119	B19	曲げ板 組 Bent plate unit	2	1B610-117	3-B1		1
1B999-527	B211	AFギア 組 AF gear unit	1	1B002-035 1B060-521 1K050-282 1K117-410 x 4 1K120-015 x 7 1K120-075 x 2 1K130-497 x 4 1K277-136 1K601-187 1K611-738 x 2 1K611-744 1K611-745 1K611-746 1K611-750 1S258-016-1 1S811-548 1S811-549 1S811-550 1S811-551 1S811-552 B1-14030FA x 2 R1-02600FA S1-02000FA	2-B3		1
1B999-528	Z193	ガラスエンコーダ 組 Lens barrel unit	1	1G766-001 1K521-165 1K641-177	2-A1		1

部組品表 Assembly List

JAA32651-R. 3311. B

部組番号 Part No.	補助番号 Ckt No.	名称 Name	1台分 個数 Pcs. Per Unit	構成部品番号 Constituent Parts	参照 図番 Fig. No.	備考 Remarks	要求単位 Q'ty per order
1B999-529	B154	フォーカスレンジ スイッチ組 Swich unit	1	1K117-406 1K206-096 1K240-832 1K681-479 1S424-033 1S700-343 1S811-526 1S811-527 1S811-528 HI-17030FA x 4	3-C3		1
1B999-530-3 (1B999-530-1)	B1028	LED 部 組 LED unit	1	1G767-001 1K117-437 1K117-525 1K117-527 1K681-463-1 1S260-058 1S700-345 1S020-086-1 1S811-537 1S811-538 1B998-123	1-D2	RP-9530	1
1B999-530-4							
1B999-534	B330	ガイド環 $+0.04$ $\phi 5 +0.03$ Guide ring	0~3	1K117-563 1K130-238-1	2-A2		1
1B999-535		ガイド環 $+0.03$ $\phi 5 +0.02$ Guide ring	0~3	1K117-564 1K130-238-1	2-A2		1
1B999-536		ガイド環 $+0.02$ $\phi 5 +0.01$ Guide ring	0~3	1K117-565 1K130-238-1	2-A2		1
1B999-537		ガイド環 $+0.01$ $\phi 5 0$ Guide ring	0~3	1K117-566 1K130-238-1	2-A2		1
1B999-538		ガイド環 0 $\phi 5 0$ Guide ring -0.01	0~3	1K117-567 1K130-238-1	2-A2		1
1G027-072	L1	G7.G8 レンズ 組 G7.G8 lens element	1	1G153-064 1G213-031	2-B2		1

部品对照表 Parts Reference Table

補助番号 Auxiliary No.	部品番号 Part Number	補助番号 Auxiliary No.	部品番号 Part Number	補助番号 Auxiliary No.	部品番号 Part Number
G1	1G713-020	45	1K521-171	84	1K681-475
G2	1G156-052	46	1K521-172	85	1K208-143
G3	1G115-051	47	1K641-169	86	1K681-453
G4	1G216-026	48	1K521-173	87	1K240-829
G5	1G252-037	49	1K500-836	88	1K611-733
G6	1G152-062	50	1K500-837	89	1K204-004-1
G7	1G153-064	51	1K611-731	90	1K130-495
G8	1G213-031	52	1K611-711	91	1K680-024
G9	1G212-017	53	1K611-712	92	1K480-001-1
G10	1G113-085	54	1K117-429	93	1K500-082-2
G11	1G253-037	55	1K240-826	94	1K681-476
G12	1G154-117	56	1K240-827	95	1K120-219
G13	1G610-002-1	57	1K470-094	96	1K225-067-1
G14	1G766-001	58	1K485-207	97	1K681-477
G15	1G767-001	59	1K117-403	98	1K240-835
		60	1K515-236	99	1K133-007
21	1K300-071-1	61	1K521-174	100	1K680-843
23	1K314-270	62	1K521-175	101	1K340-133
24	1K530-067	63	1K681-450	102	1K371-706
25	1K510-404	64	1K681-451	103	1K220-021-1
26	1K475-494	66	1K641-170	104	1S800-001-1
27	1K302-066	67	1K641-171	105	1K485-152-1
28	1K475-401-1	68	1S700-344	106	1K110-385
29	1K630-802	69	1K400-342	107	1K611-714
30	1K404-114	70	1K380-045-2	108	B1-17020FA
31	1K570-074	71	1K681-474	109	1K240-830
32	1K370-111-1	73	1K240-828	110	1K611-716
33	1K574-114	74	1K070-022	111	1K641-173
34	1K572-159	75	1K611-732	112	1K260-620
35	1K641-167	76	1K340-231	113	B1-17028FA
36	1K240-790	77	1K126-102	114	1K160-056-1
37	1K110-383	78	1K641-172	115	1K681-478
38	1K641-168	79	1K600-563	116	A1-17035FA
39	1K630-803	80	1K521-176	117	1K641-174
41	1K630-804	81	1K310-008-1	118	1K521-177
42	1K521-169	82	1K640-671	119	1K246-090
43	1K500-835	83	1K610-843	120	1K120-036-1
44	1K521-170				

部品对照表 Parts Reference Table

補助番号 Auxiliary No.	部品番号 Part Number	補助番号 Auxiliary No.	部品番号 Part Number	補助番号 Auxiliary No.	部品番号 Part Number
121	1K371-759	167	1K641-175	198	1K641-160
122	A1-17055FA	168	1K641-176	199	1K314-271-1
124	1K130-304	170	1K611-736	200	1K611-751
125	1K120-091	171	1K611-718	201	1K240-831
	1K120-007-2	172	1K208-097	203	1K117-407
126	1K120-018	173	1K240-563	204	1K601-220
127	1K120-010-1	174	1K233-008-2	205	1K681-462
128	1K110-037	175	1K521-178	206	1K681-463
129	1K120-012	176	1K110-384	207	1K611-721
130	1K115-105	177	1K161-151	208	A1-17020FA
131	1K600-043		1K161-152	209	1K611-739
132	1K370-115		1K161-153	210	1B060-498
133	1K370-116		1K161-154	211	1K601-182
134	1K370-117		1K161-155	212	1K601-183
135	1K100-031		1K161-156	213	1K371-708
136	1K681-454		1K161-157	214	P3-10050SX
137	1K630-819		178	1K640-672-1	216
138	R5-02000FA	179	1K161-158	217	1K120-075
139	1K001-002-1	180	1K117-465	218	R1-02600FA
140	1K611-734	181	1K260-621	222	A2-17030FA
141	1K611-735	182	1K220-354	223	1K277-136
145	1K120-304	183	1K130-496	224	1K277-139
148	A2-14025FA		1K130-504	225	1K681-480
149	1K240-469-1	184	S1-02000FA	226	1K681-481
150	1K601-180	185	1K260-612	228	A2-17035FA
151	1K681-479	186	1K260-613	229	1K371-709
152	B1-20040FB	187	1K220-357	230	B1-14030FA
154	1K117-406	188	1K225-231	232	1K371-710
155	A2-20040FT	189	1K611-720	235	1K611-750
156	1S424-033	190	1K260-622	239	1K133-085
157	1S422-054	191	1K611-737	240	1K060-058
158	1K010-002-1	192	1K630-793	241	B2-20050FA
159	B1-20055PR		1K630-817	242	1K050-367
160	1K370-028-3		1K630-818	243	1K116-450
161	1K625-059	193	1K521-165		1K116-451
164	1K277-134	194	1K641-177		1K116-452
165	1K371-707	195	1K130-208		1K116-453
166	H1-17030FA	197	1K611-738		

部品对照表 Parts Reference Table

補助番号 Auxiliary No.	部品番号 Part Number	補助番号 Auxiliary No.	部品番号 Part Number	補助番号 Auxiliary No.	部品番号 Part Number
244	1K130-328	291	1K120-009	331	1K117-563
245	1K117-410	292	1K120-368		1K117-564
246	1K130-497	293	1K630-805		1K117-565
247	1K230-391	294	K2-20025FA		1K117-566
248	1K130-498	295	B2-17040FA		1K117-567
252	K2-17035FB	297	A1-17025FT		
254	1K681-468	298	1K120-300		
255	1K120-264	301	1K600-045-1		
256	B2-20040FA	302	1K042-001		
257	B1-20050FA	303	1K370-114		
258	A2-17045FA	304	1K681-482		
259	B1-17055FT	305	1K161-159		
260	1K120-231	306	1K117-437		
261	A2-14025FC	307	1K001-003-1		
262	1K681-464	308	1K120-369		
263	1K681-465	309	1K601-187		
264	1K120-012	310	1K117-440		
266	H1-17040FA	311	1K117-525		
267	1K601-174	312	1K117-526		
268	1K601-175	313	1K117-413		
269	1K087-411	314	1K117-462		
270	U2-06310SX	315	1K641-181		
271	1K681-466	316	1K611-746		
272	1K611-827	317	1K611-745		
273	1K467-154	318	1K611-744		
274	1K206-096	319	1K601-176		
275	1S700-343	320	1K220-369		
276	1K240-832	321	1K116-626		
277	K2-17020FB	322	1K050-411		
278	A1-17025FA		1K050-407		
279	A1-14028FA	324	1K681-539		
280	B1-20040FA	325	1K117-485		
281	1K120-015	327	1K117-228		
282	1K120-195	328	1K117-527		
284	1K120-142	329	1K050-282		
288	B1-17035FA	330	1K130-238-1		
289	1K010-150				
290	1K600-764				

部品对照表 Parts Reference Table

補助番号 Auxiliary No.	部品番号 Part Number	補助番号 Auxiliary No.	部品番号 Part Number	補助番号 Auxiliary No.	部品番号 Part Number
B19	1B610-119	B1001	1B060-501		
B21	1B300-024	B1003	1B060-505		
B23	1B314-138	B1004	1B060-506		
B27	1B002-043	B1005	1B060-507		
B31	1B570-074	B1006	1B060-508		
B33	1B574020-4	B1028	1B999-530-1		
B35	1B002-034				
B69	1B400-085				
B71	1B240-094	L1	1B027-072		
B82	1B001-661-1				
B86	1B002-025				
B109	1B240-091				
B121	1B260-101				
B136	1B002-026				
B154	1B999-529				
B210	1B060-521				
B211	1B999-527				
B220	1B060-517				
	1B999-534				
	1B999-535				
B33	1B999-536				
	1B999-537				
	1B999-538				
Z25	1B100-634				
Z43	1B100-635				
Z49	1B100-633				
Z93	1B100-038-4				
Z193	1B999-528				

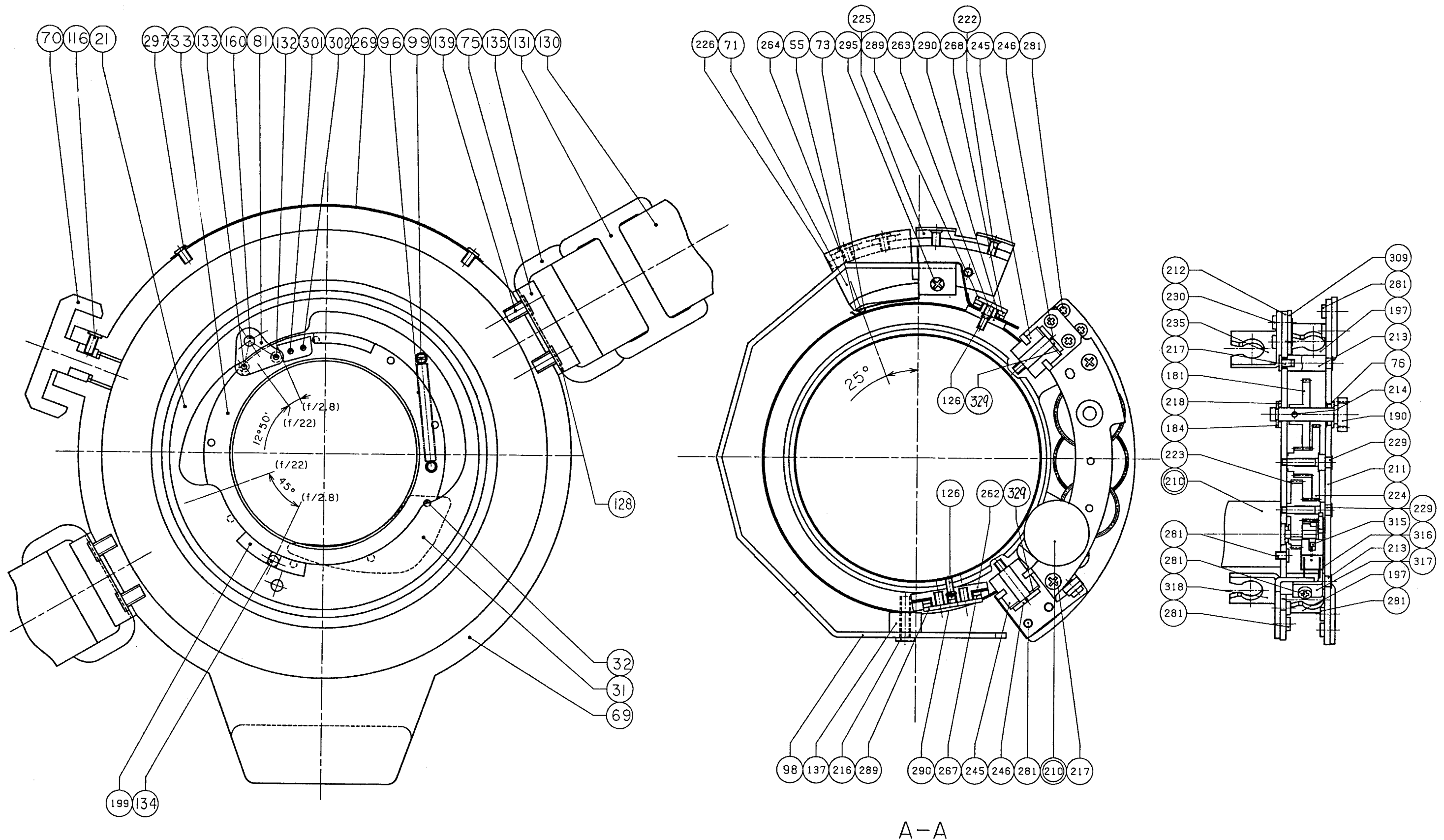

絞り部及び三脚座部(後方より)

Note) When ordering the repair parts, please use the parts numbers stated on the Repair Parts List. Please note that some of those numbers stated on the Parts Number Reference Table, the Exploded Drawings and the Lubricant and Binding Agent Chart are not included in the Repair Parts List since they are not available as the individual repair parts.

注) 部品対照表、組立図、接着給油図には部品要求出来る番号と要求出来ない番号と記載されています。部品要求の際は、部品表で確認の上、要求して下さい。部品表に記載されていない部番は部品要求出来ません。

Fig. 5

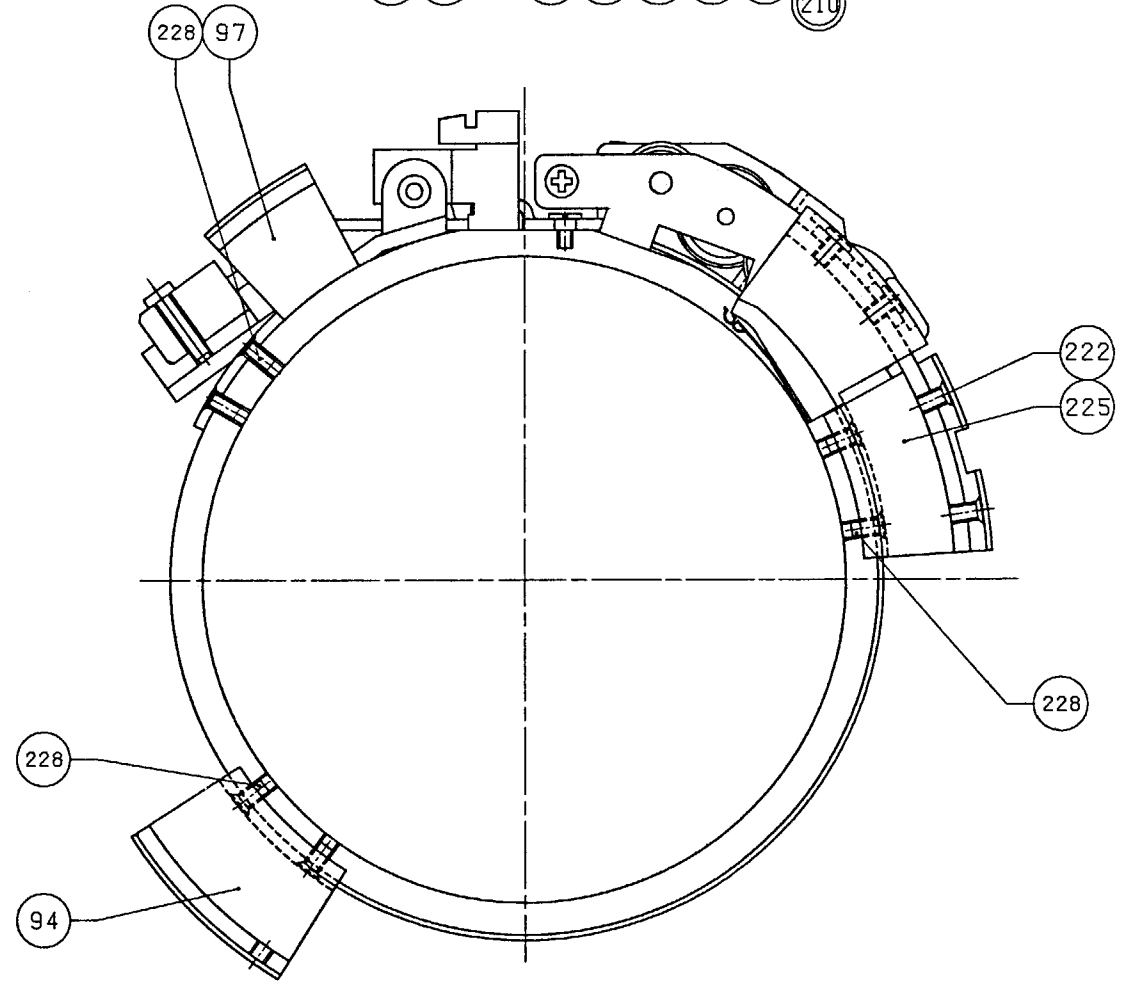
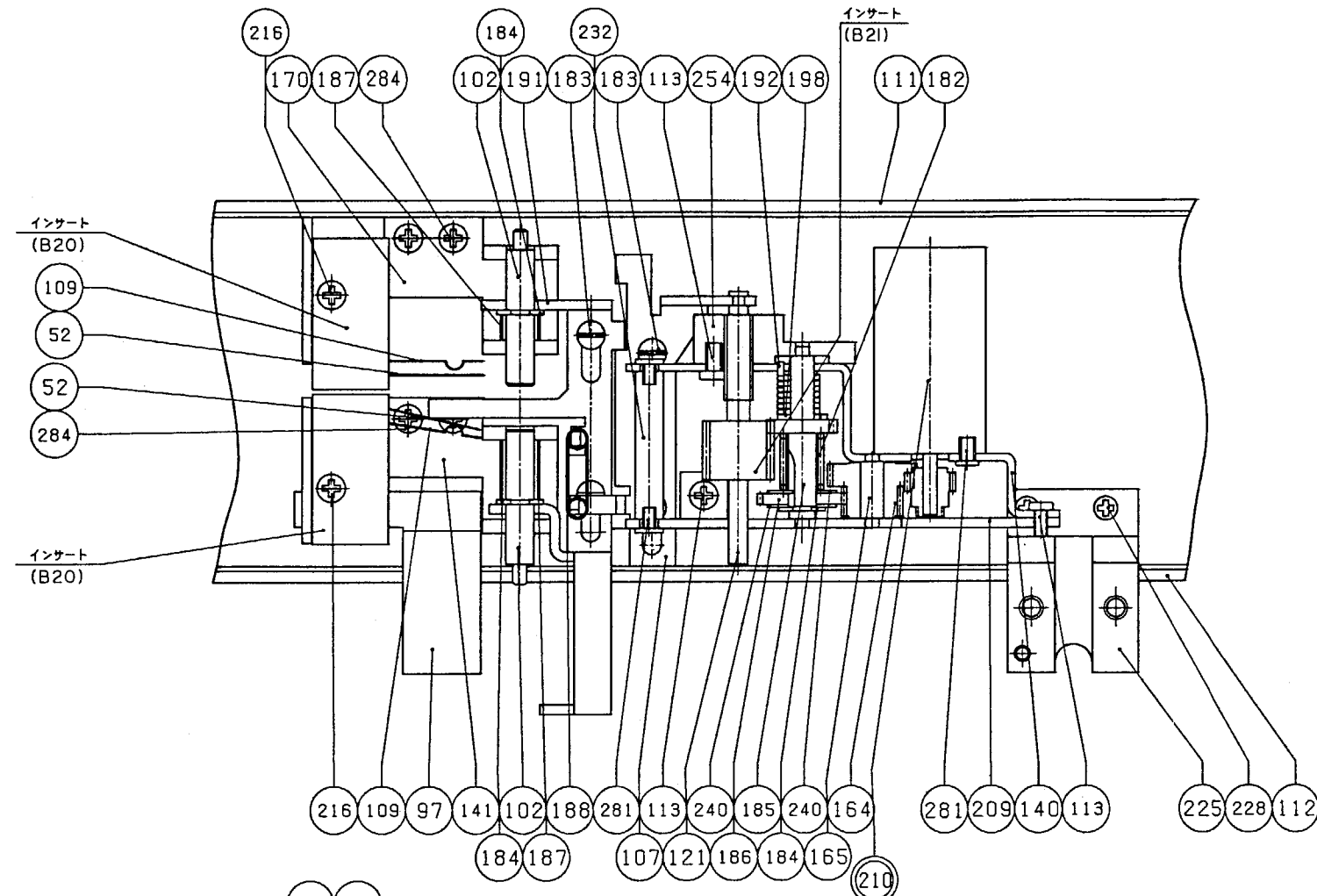

c-c

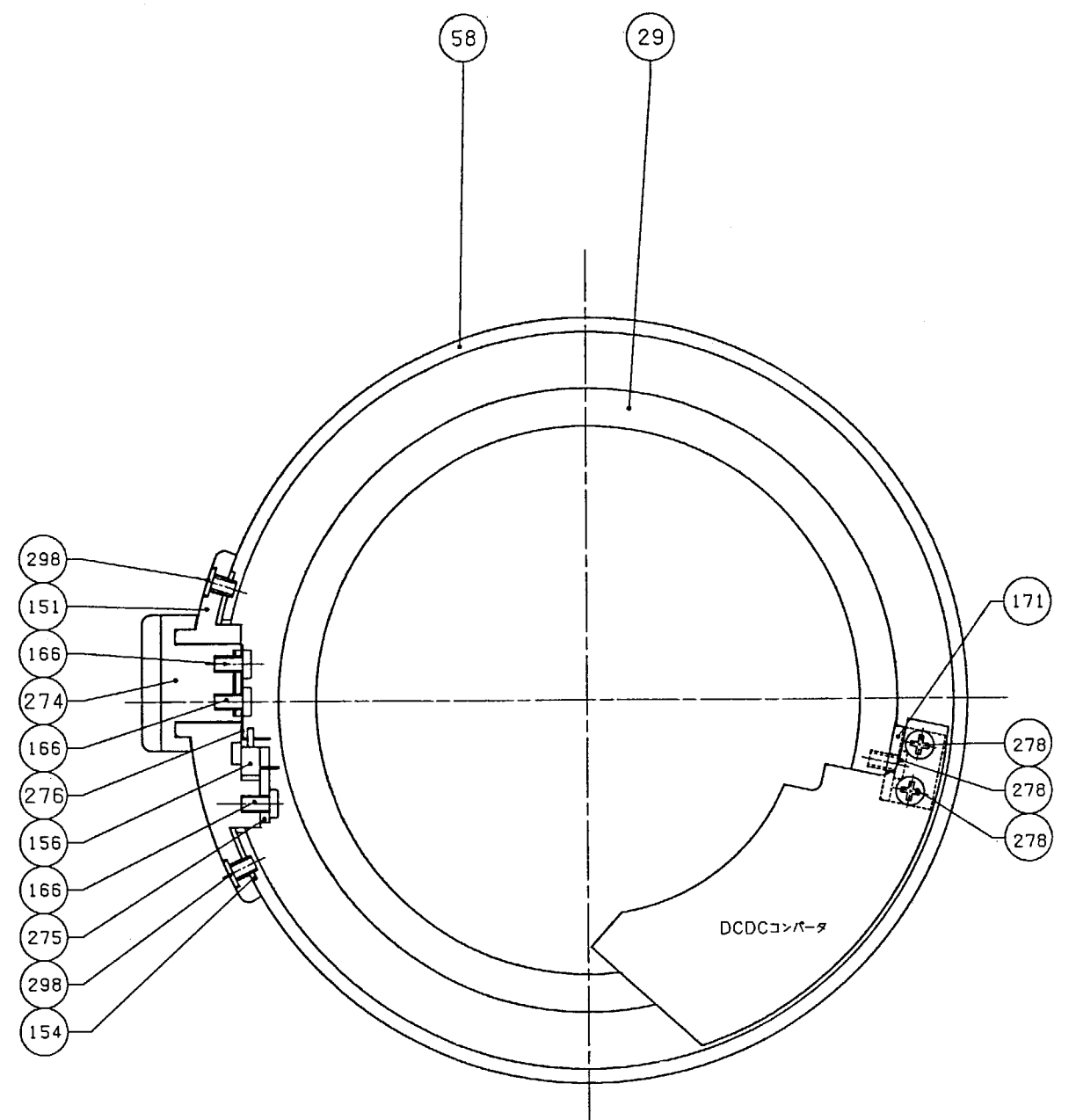

D視

Fig. 6

モーター部 (後方より)

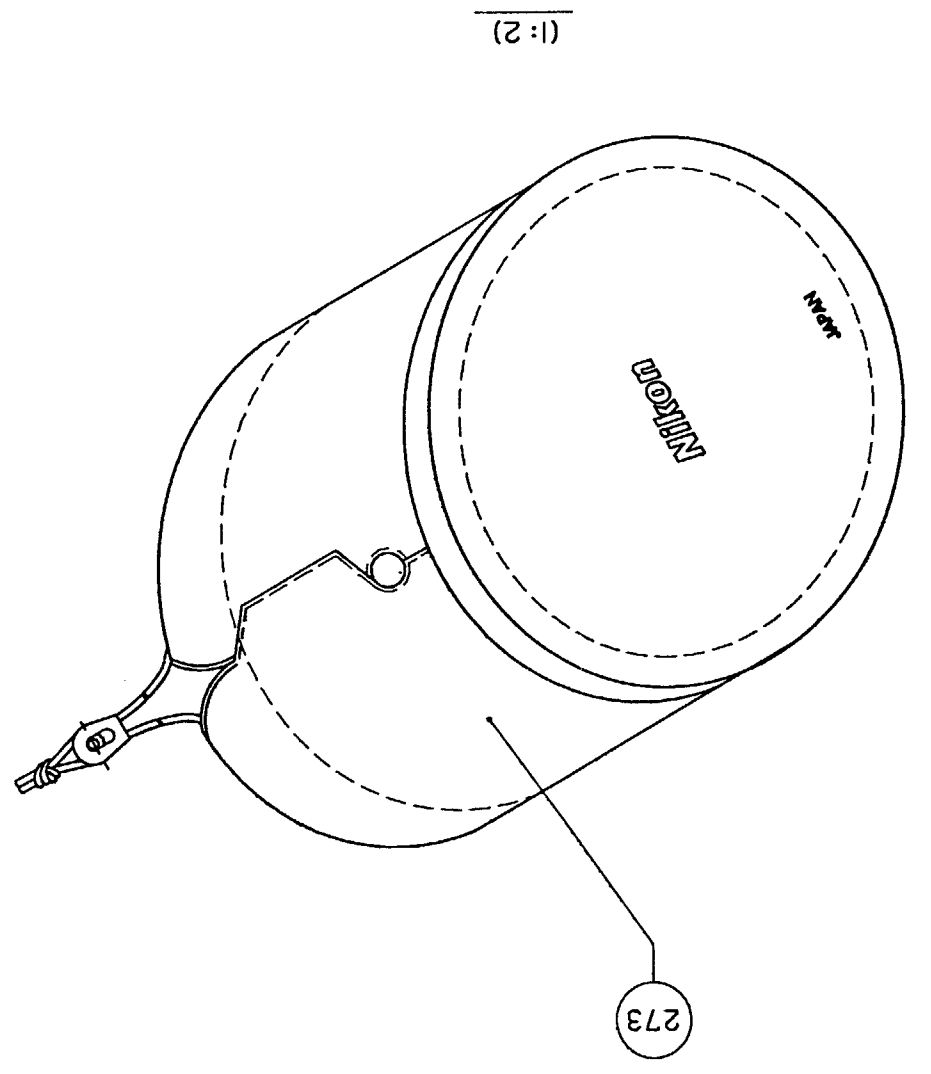
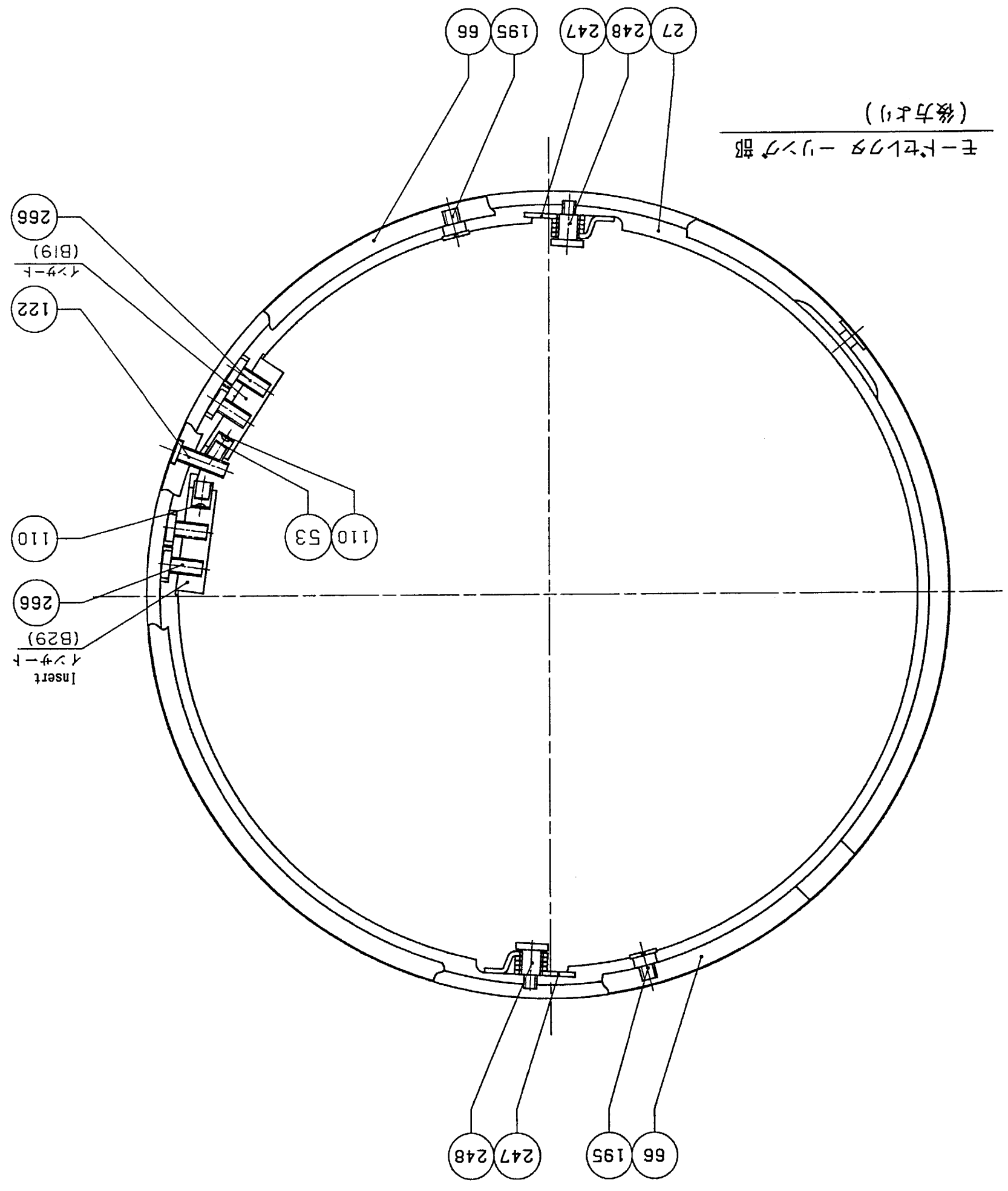
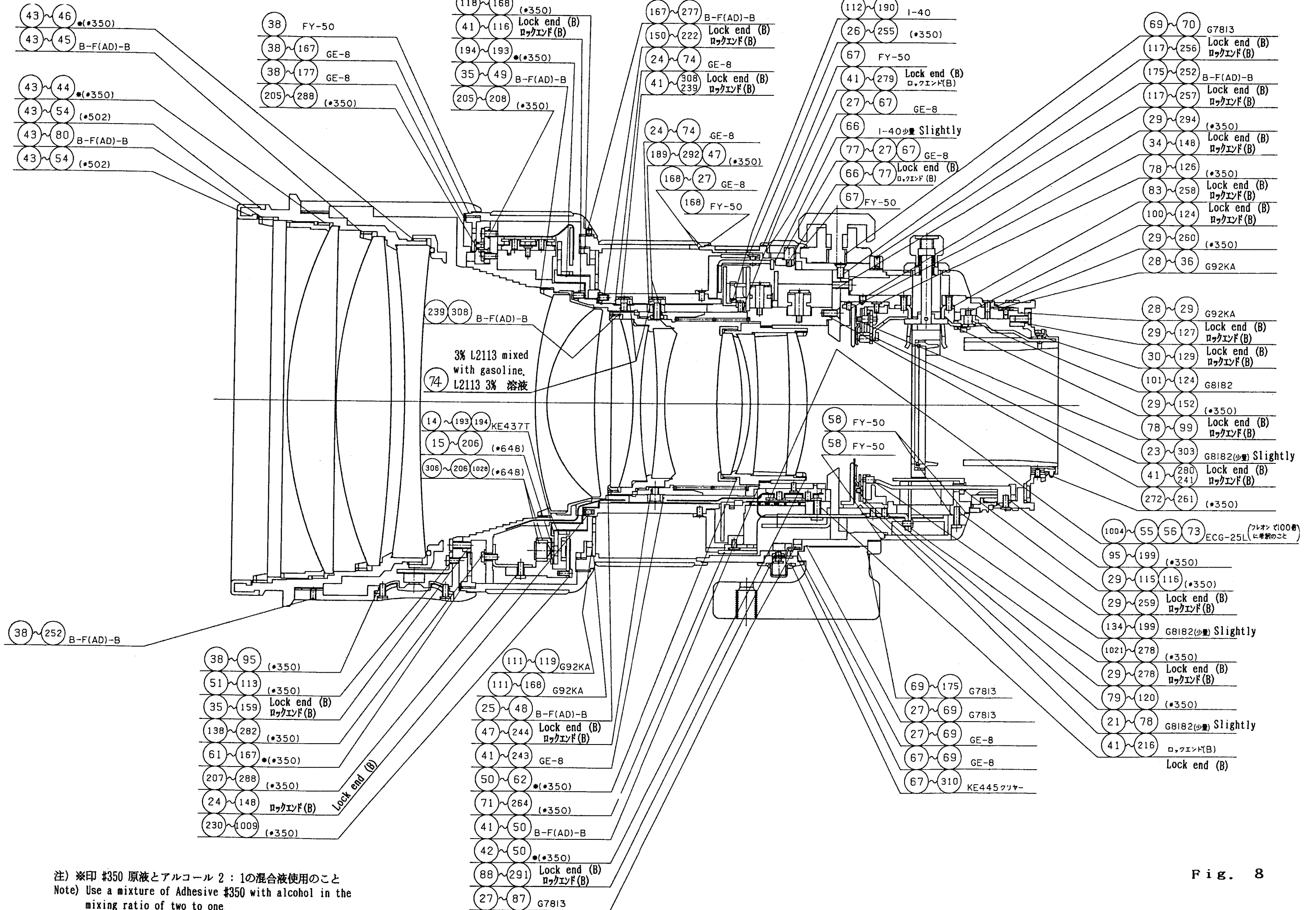

FIG. 7



注) ※印 #350 原液とアルコール 2 : 1の混合液使用のこと
 Note) Use a mixture of Adhesive #350 with alcohol in the mixing ratio of two to one.

Fig. 8

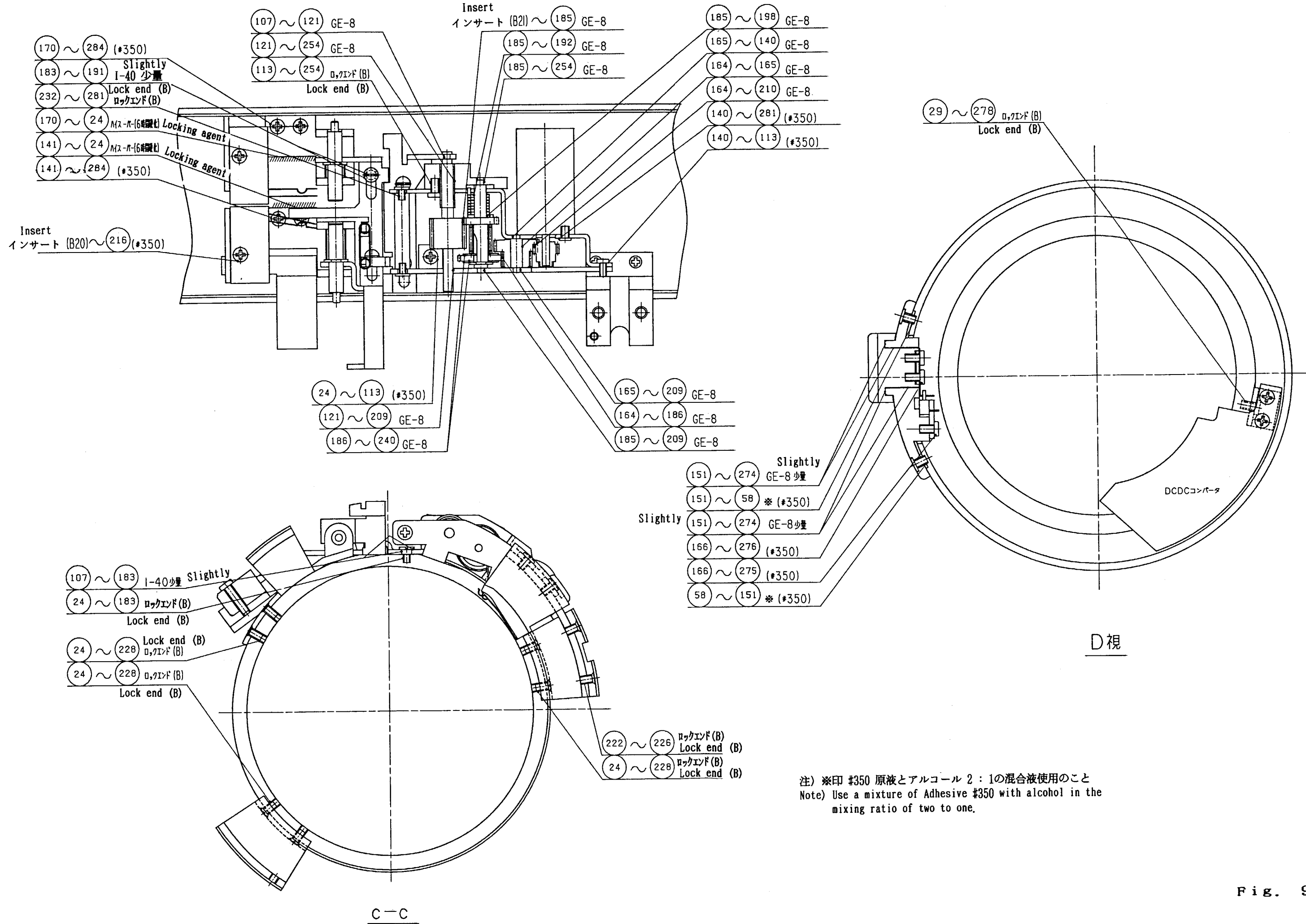
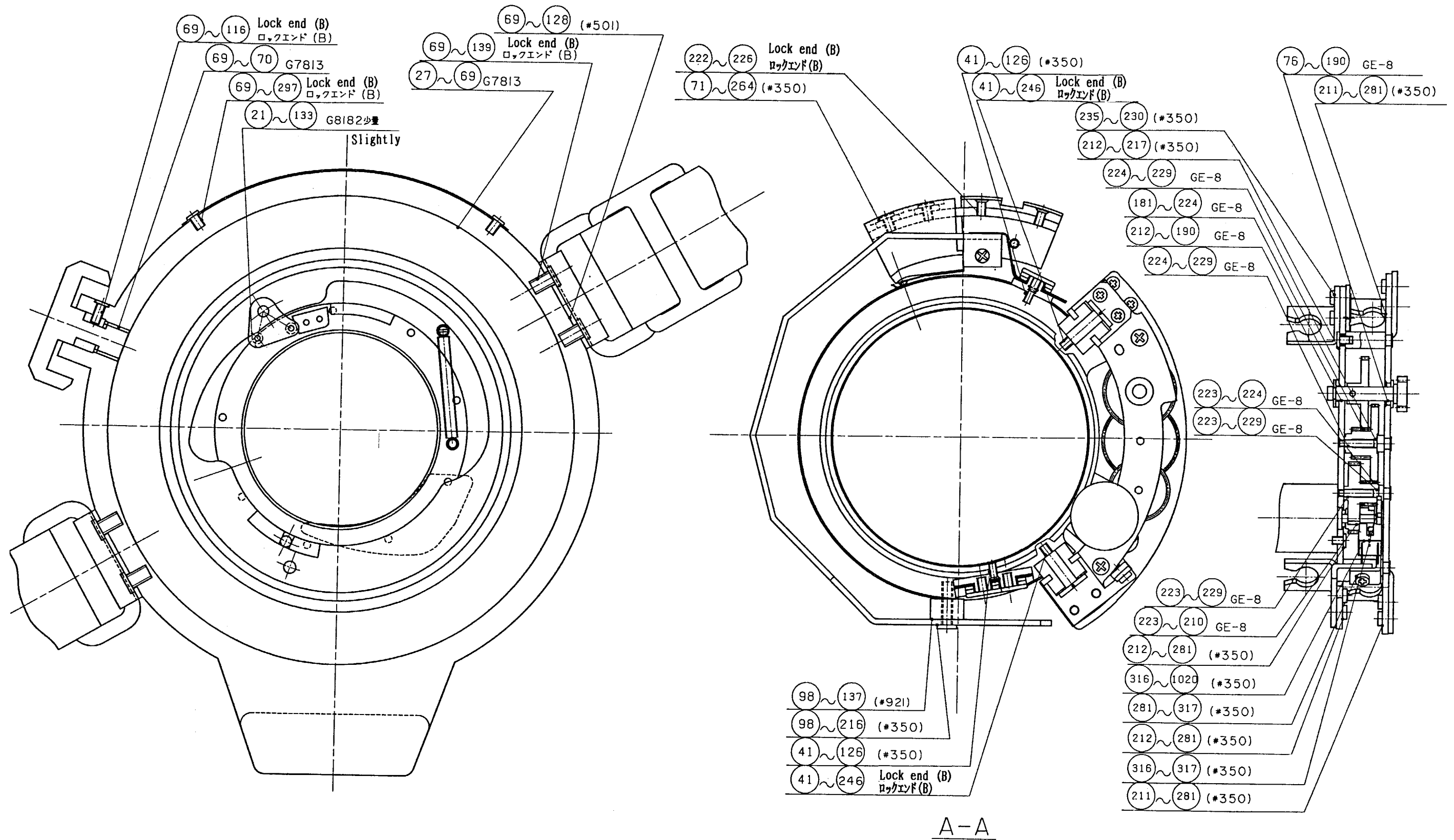

Fig. 9



絞り部及び三脚座部(後方より)

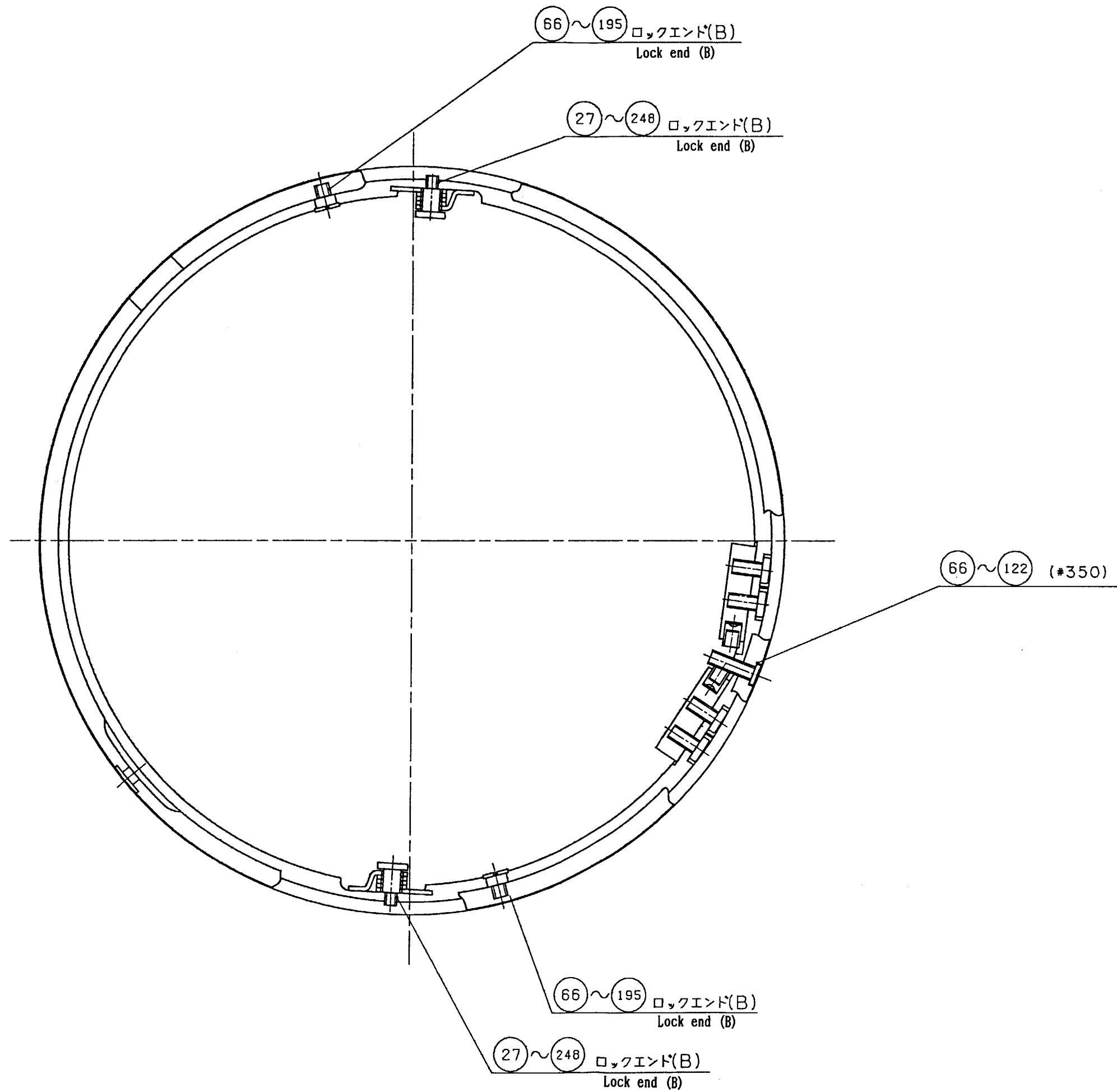

Fig. 11