

作成承認印

配布許可印



AF-S DX Nikkor ED 18-55/3.5-5.6G

JAA79201 Silver

JAA79251 Black

REPAIR MANUAL

Nikon | NIKON CORPORATION
Tokyo, Japan

Copyright © 2005 by Nikon Corporation.
All Rights Reserved.
無断転載を禁ず !!

Specifications

Type of lens:	G-type AF-S DX Zoom-Nikkor lens with built-in CPU and Nikon bayonet mount (Specially designed for use with Nikon digital SLR – Nikon DX format – cameras)
Focal length:	18mm–55mm
Maximum aperture:	f/3.5–5.6
Lens construction:	7 elements in 5 groups (1 ED and 1 aspherical lens elements)
Picture angle:	76° – 28°50′
Focal length scale:	18, 24, 35, 45, 55mm
Distance information:	Output to camera body
Zoom control:	Manually via separate zoom ring
Focusing:	Autofocus using a Silent Wave Motor; manually via separate focus ring
Closest focus distance:	0.28m (0.9 ft.) at all zoom settings
Diaphragm:	Fully automatic
Aperture range:	f/3.5 to f/22 (at 18mm), f/5.6 to f/38 (at 55mm)
Exposure measurement:	Via full-aperture method
Attachment size:	52mm (P = 0.75mm)
Dimensions:	Approx. 69mm dia. x 74mm extension from the camera's lens-mount flange
Weight:	Approx. 210g (7.4 oz)

• Specifications and designs are subject to change without any notice or obligation on the part

Disassembly / Assembly / Adjustment

Note:

- ① When disassembling, make sure to memorize the processing state of wires and FPC.
- ② Because prototypes are used for "Disassembly/(Re)assembly/Adjustment", they may differ from the actual products in forms, etc.
- ③ Because pictures are processed by a special method, they may differ from the actual ones in texture.

Points to notice for Lead-free solder products

- Lead-free solder is used for this product.
- For soldering work, the special solder and soldering iron are required.
- Do NOT mix up lead-free solder with traditional solder.
- Use the special soldering iron respectively for lead-free solder and lead solder. They cannot be used in common.

1. Disassembly

Company name ring

- The company name ring (#113) is attached with the both-sided adhesive tape.



Name plate



Note: Detaching the name plate (#68) is NOT necessary EXCEPT replacing it.

Rear cover ring

- Take out 3 screws (#91) to remove the rear cover ring (#39).



Rubber ring

- Remove the rubber ring (#62).



Ist lens group

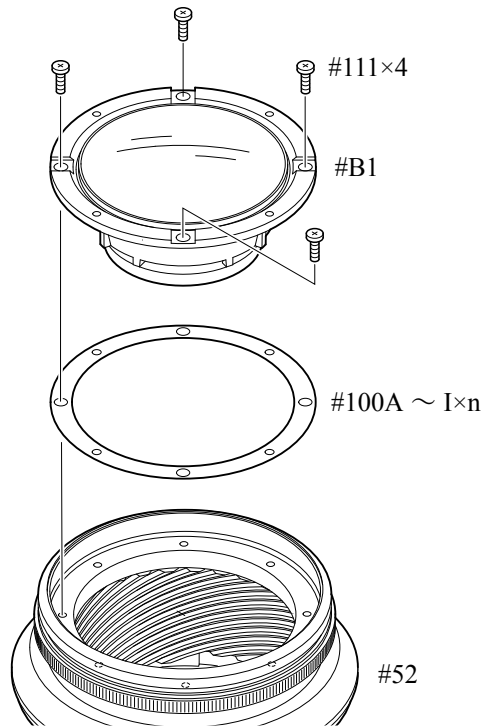

Distance brush hole-sealing plate

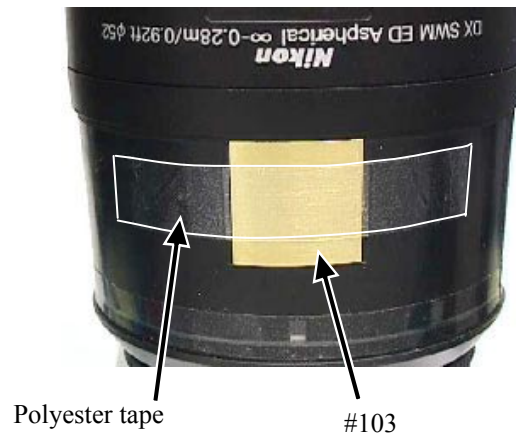

Removal of Contact unit

- Take out 2 screws (#67) of the contact unit (#B6) that is attached to the bayonet mount unit (#B27).

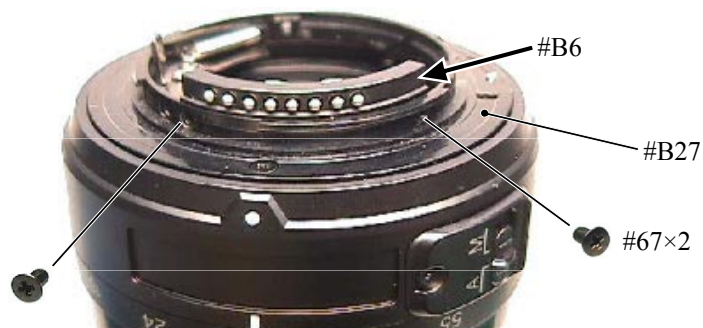

Removal of M/A change-SW unit

- Take out the screw (#155) to remove the M/A change-SW unit(#B22).

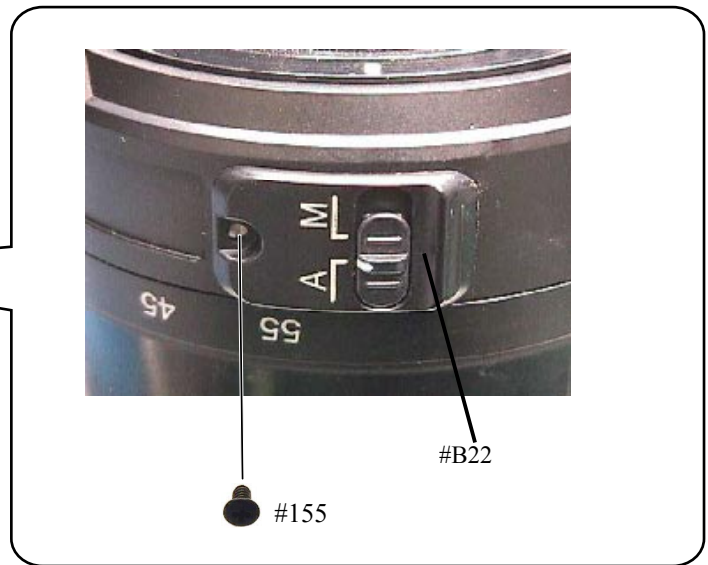

Bayonet mount unit

- Take out 3 screws (#78) of the bayonet mount unit (#B27) to remove the lead wire (#1131).

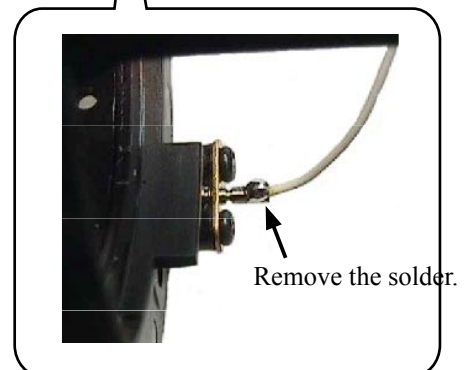
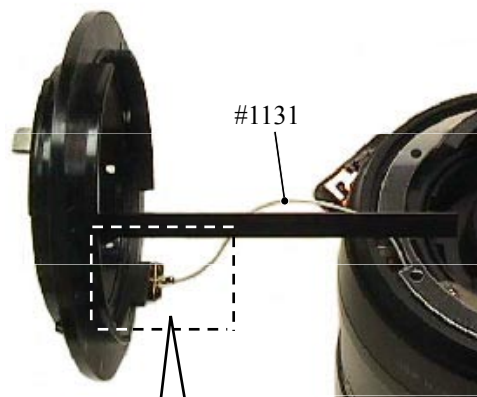
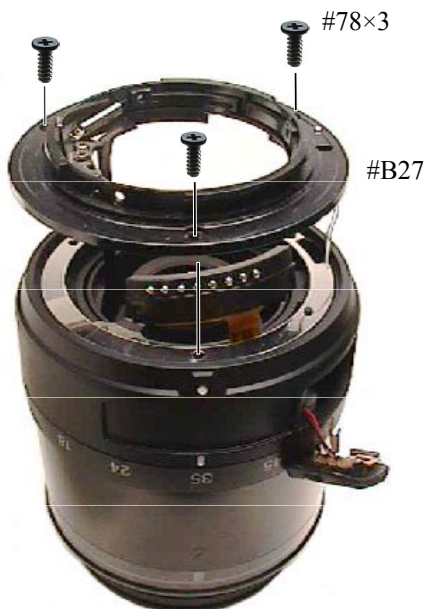

Washer

- Remove the washers (#101A ~ J×n).



Flare cutter

- Release the key part of the flare cutter (#46) from the key-groove of the cam tube, then remove the flare cutter.

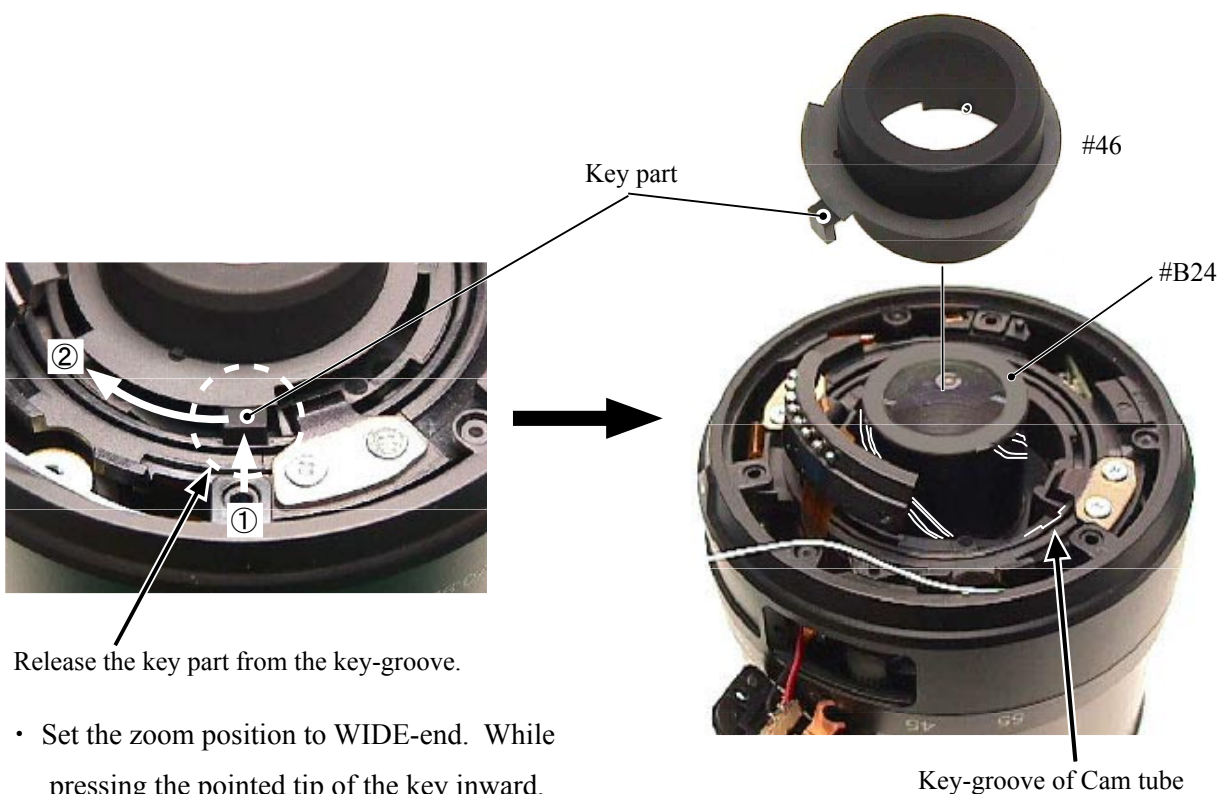

Release the key part from the key-groove.

- Set the zoom position to WIDE-end. While pressing the pointed tip of the key inward, remove the key by turning clockwise.

① → ②

Straight key unit



2nd lens group



Rear fixed tube

- Set the M/A change-SW unit (#B22) to A mode. Detach it from the window of the rear fixed tube (#57) and remove the rear fixed tube.

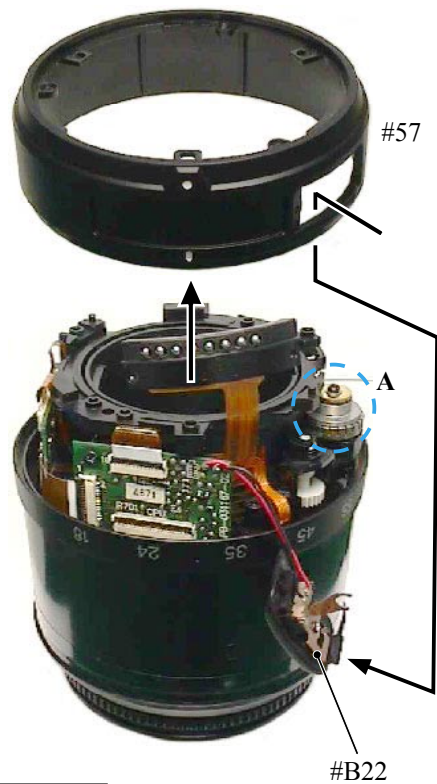

Note: Do NOT touch "A" part directly with hand.

Removal of FPC from Main-PCB unit

- Remove the SWM unit (#B501) from the main-PCB unit (#B1001).

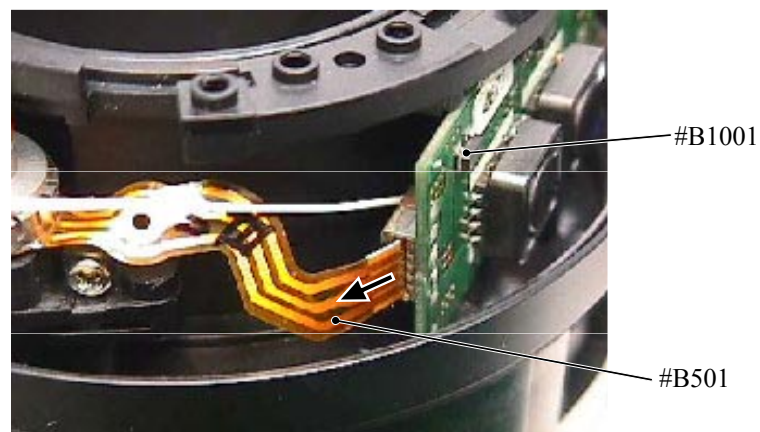

- Remove the contact unit (#B6) and MR unit (#B7) from the connector of the main-PCB unit (#B1001).

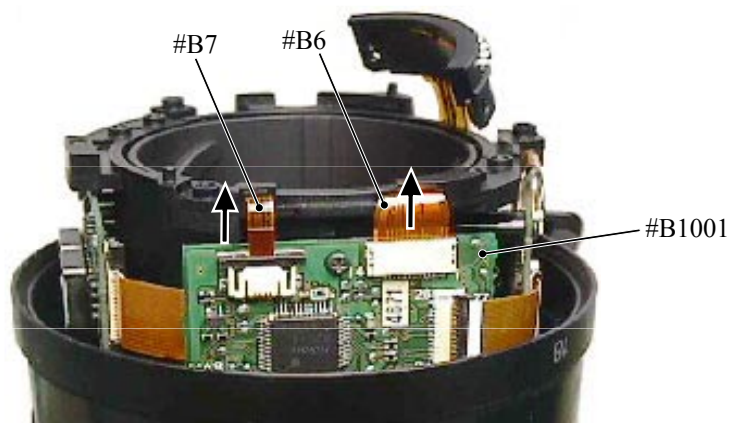

- Remove the zoom/distance FPC from the connector of the main-PCB unit (#B1001).

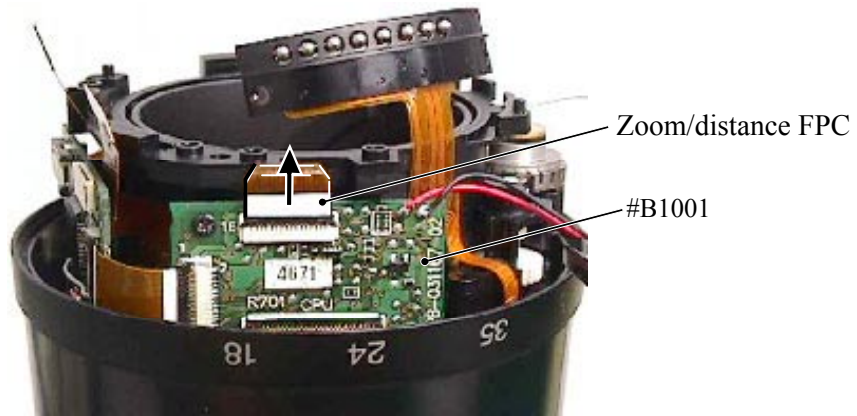

Main PCB unit

- Remove the main-PCB unit (#B1001).

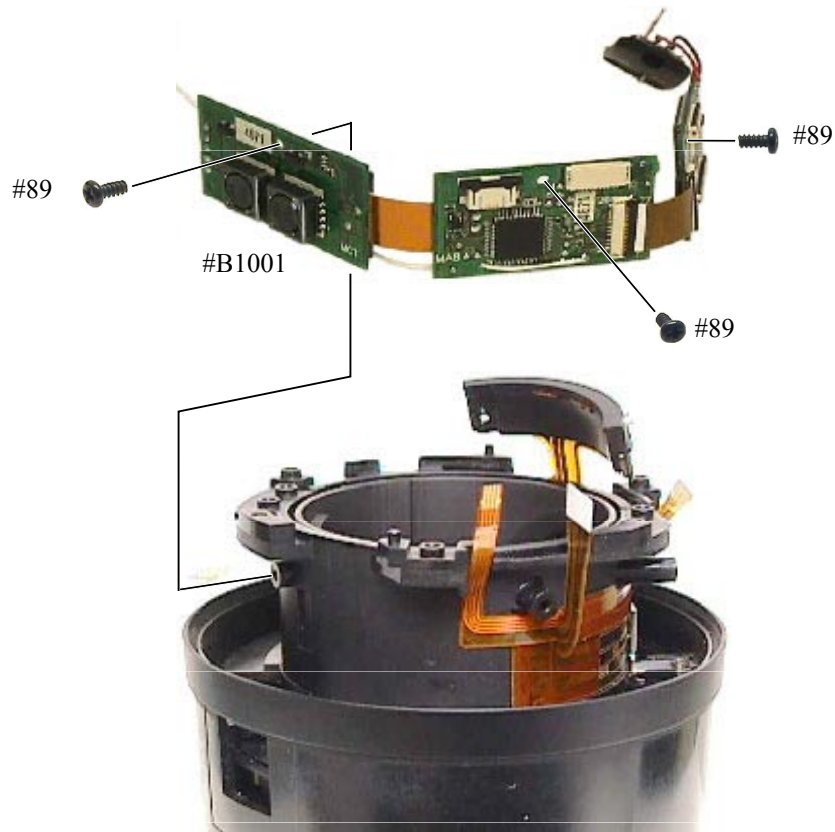

- Remove the lead wire (#1131) from the main-PCB unit (#B1001).

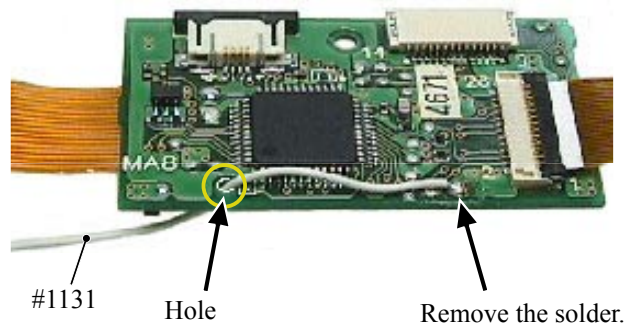

M/A change-SW unit

- Remove 2 lead wires of the M/A change-SW unit (#B22) from the main PCB unit (#B1001).

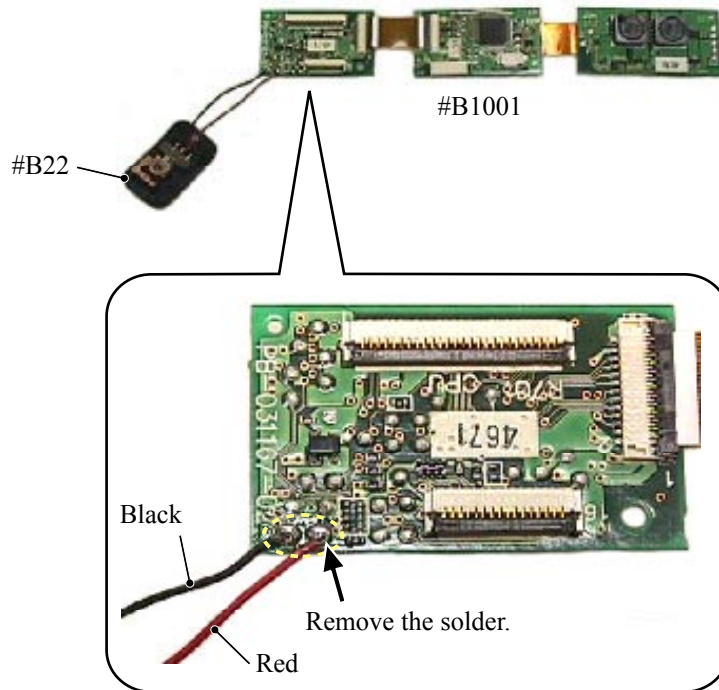

Contact unit

- Remove the contact unit (#B6).

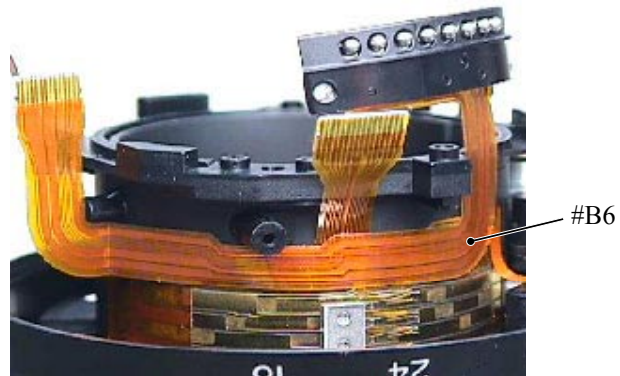

Zoom brush unit

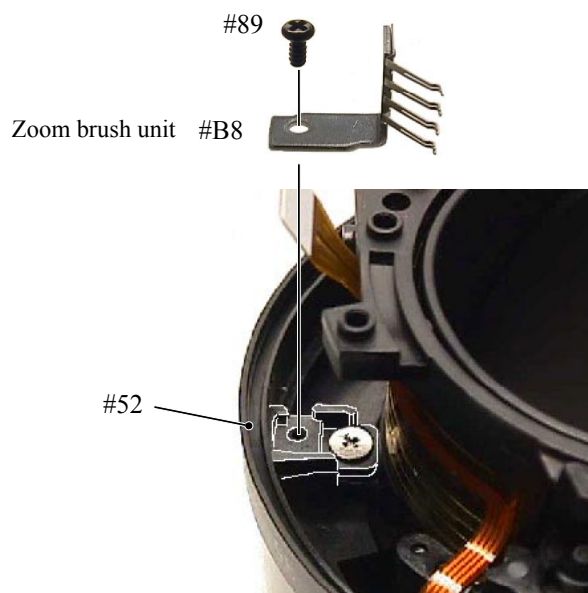

Filter ring unit

- Remove the polyester tape (#77) from the zoom ring (#52).



- While releasing the engagements of 2 keys of the focus ring, turn the filter ring unit (#B20) in the direction of the arrow to remove it.

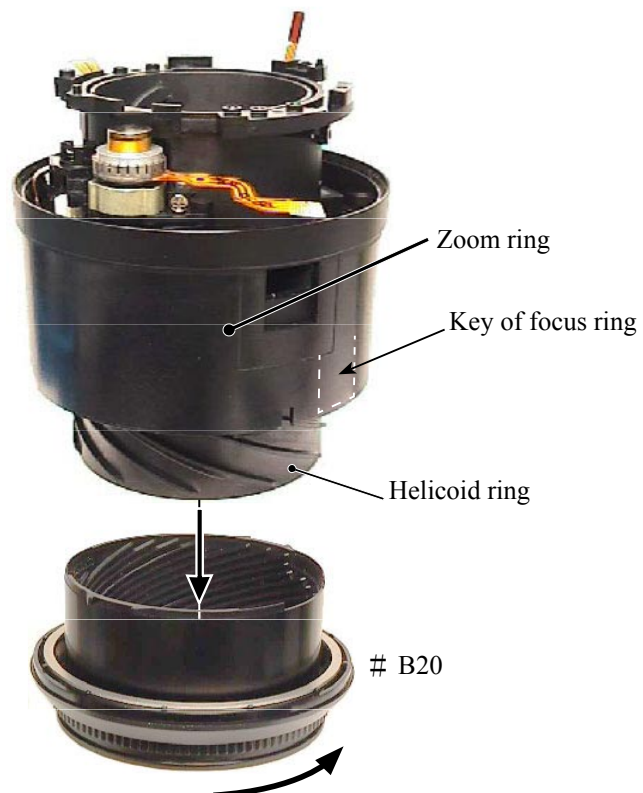

Zoom ring

- Take out 2 screws (#102) that attach the zoom ring (#52).

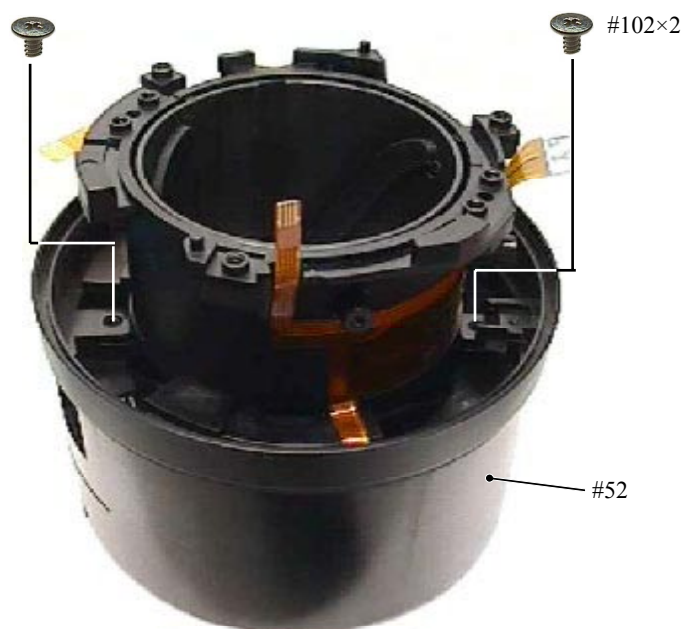

- Detach the zoom ring (#52) from the fixed tube unit.

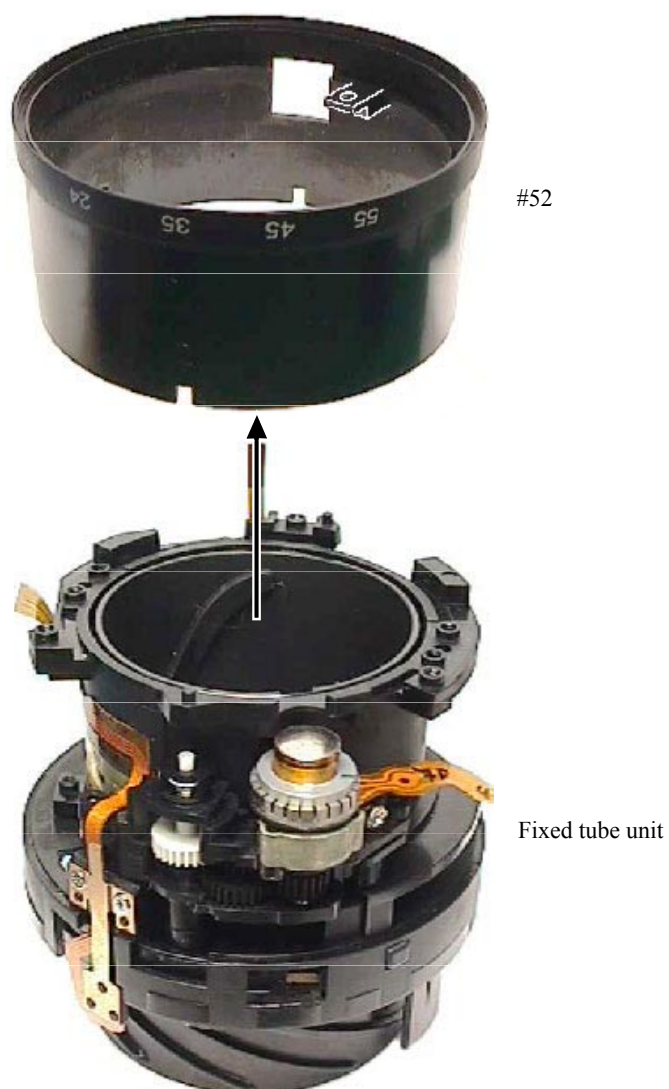

Fixed tube unit

① Silicon rubber

- Remove 2 silicon rubbers (#56) from the square grooves of the fixed tube.



② MR unit

- Remove the MR unit (#B7) from the fixed tube.

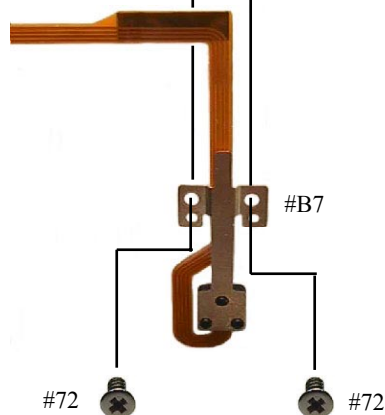
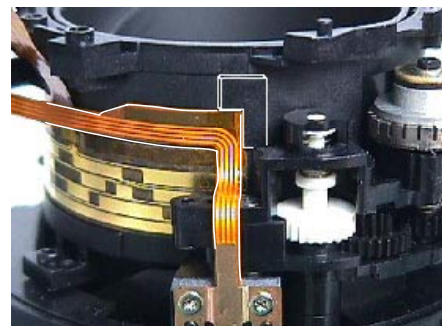

- Remove the FPC of the MR unit from the fixed tube.

③ SWM unit

- Remove the SWM unit (#B501) from the fixed tube.



④ Gear

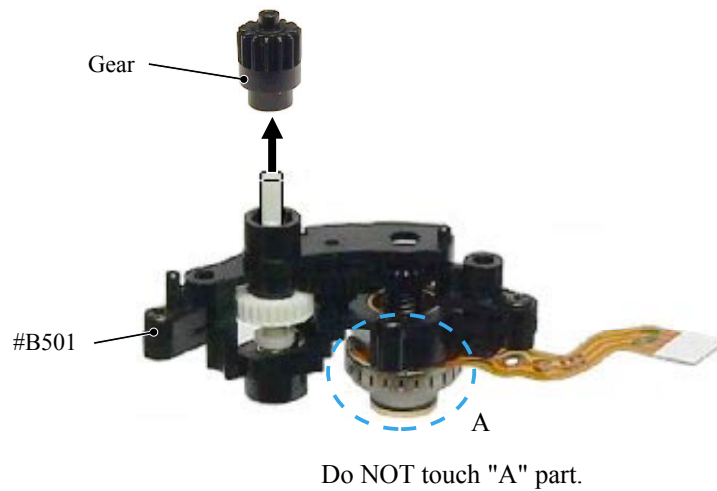

2. Assembly / Adjustment

Fixed tube unit

① Cam tube unit (Helicoid ring, Cam ring)

- Align the cam ring (3 grooves between convex portions on the outer diameter surface) with the helicoid ring (3 convex cams on the inner diameter surface) and assemble the rings by turning them.

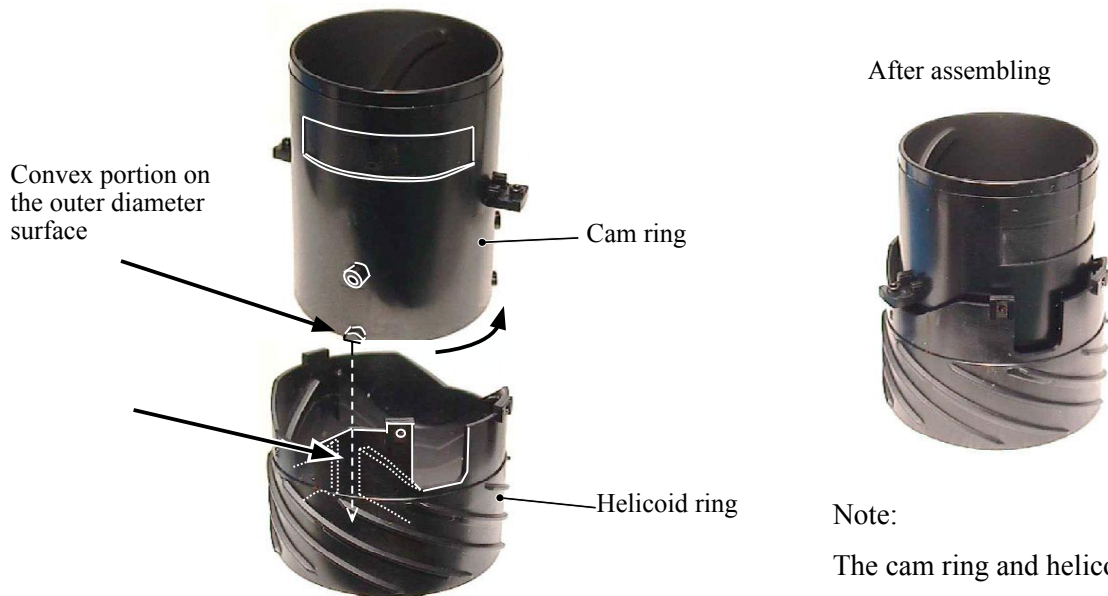

Note:

The cam ring and helicoid ring are NOT prepared as single part of RP.

② Cam tube unit / Fixed tube

- With the cam tube unit (3 outer convex portions) being at the full up WIDE position, assemble the fixed tube (3 inner grooves between cams).

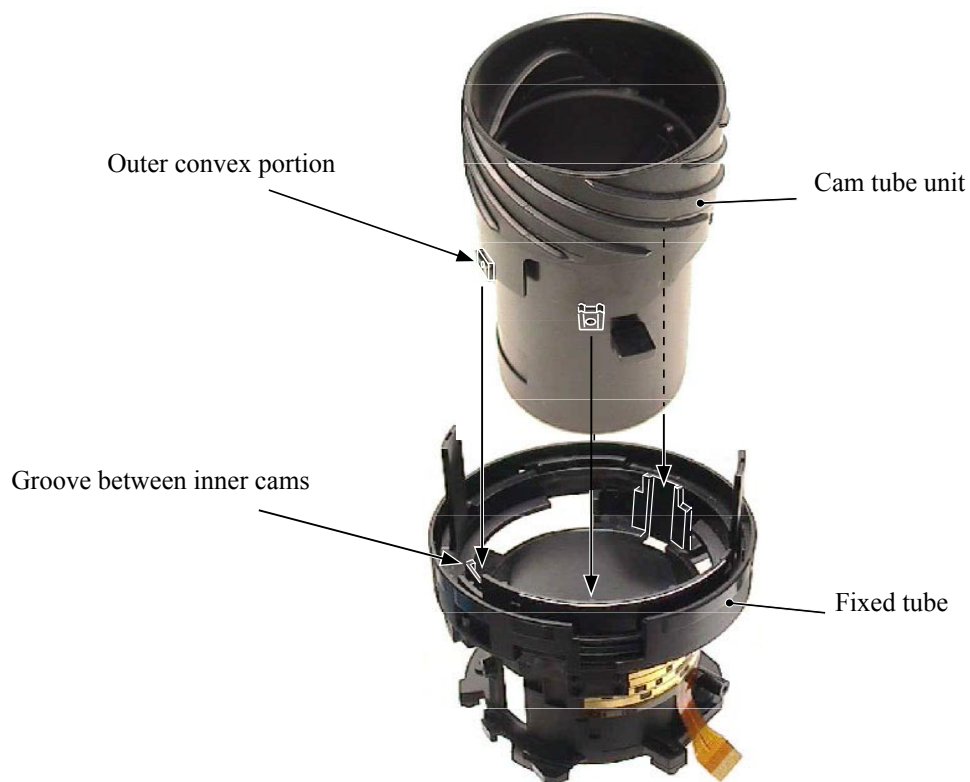

③ SWM unit

- Assemble the gear (#513) into the SWM unit (#B501) .

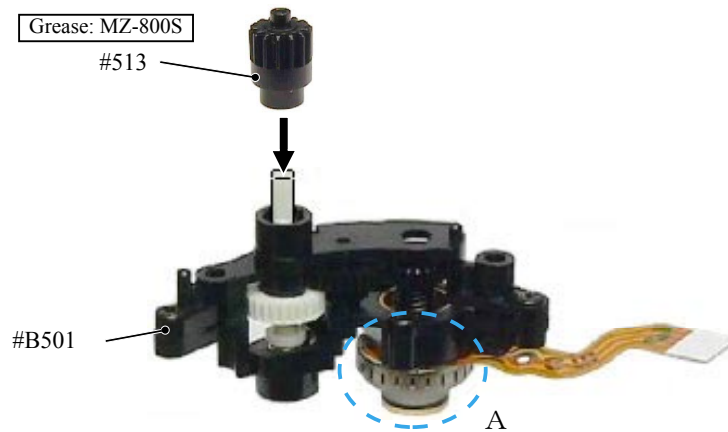

Do NOT touch "A" part.

- Assemble the SWM unit into the fixed tube.

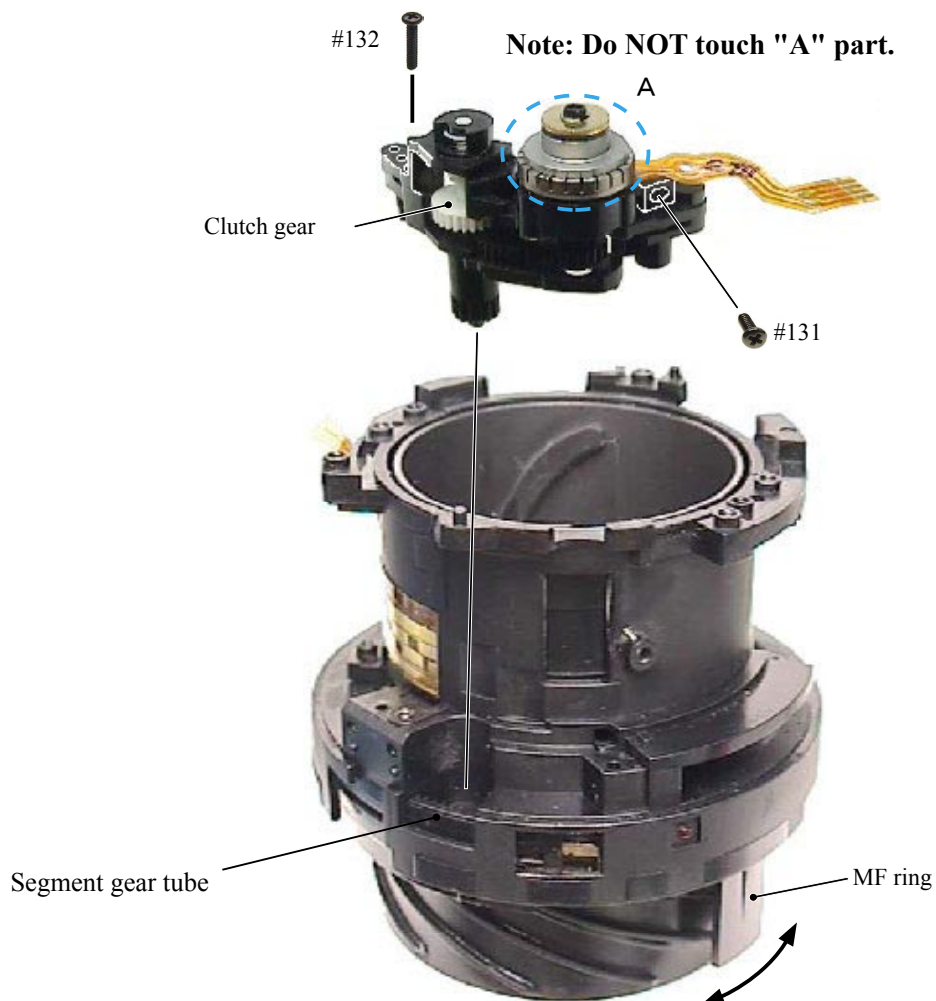

- Raise the clutch gear with tweezers, and check the engagement of the segment gear tube and the ear (#513) by turning the MF ring.
- Raise the clutch gear with tweezers, and check it moves back downwards smoothly.

④ MR unit

- Assemble the MR unit (#B7) into the fixed tube.

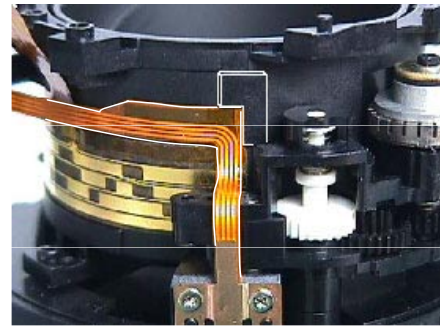
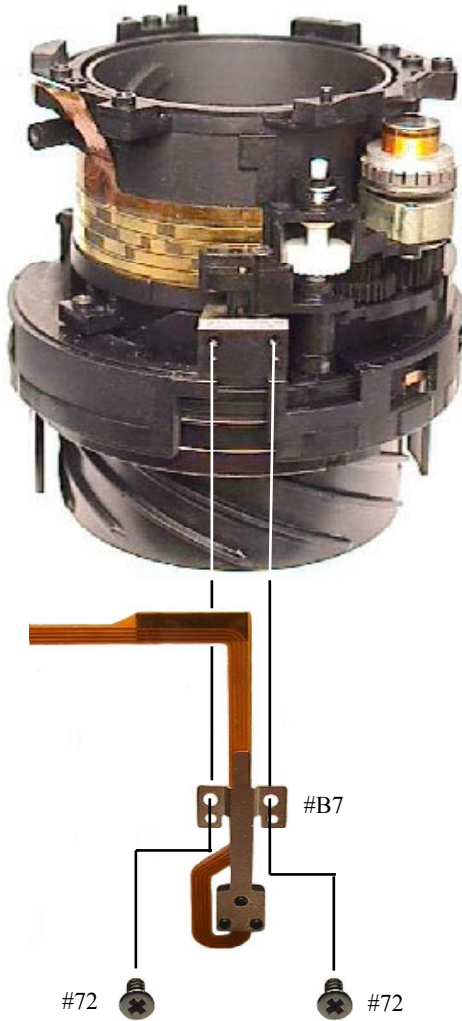

- Attach the FPC of the MR unit on the fixed tube, and press it with fingers.

- Put the silicon rubbers (#56) into 2 square grooves of the fixed tube, and press them (with fingers).

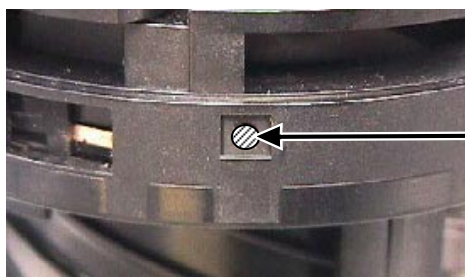

Square groove×2

Adhesive: Screwlock



#56



#56

Zoom ring

- Align 2 notches of the fixed tube with 2 convex portions of the zoom ring (#52) to assemble them. Then turn the zoom ring, and fit 2 convex portions of the cam ring into 2 holes of the zoom ring.

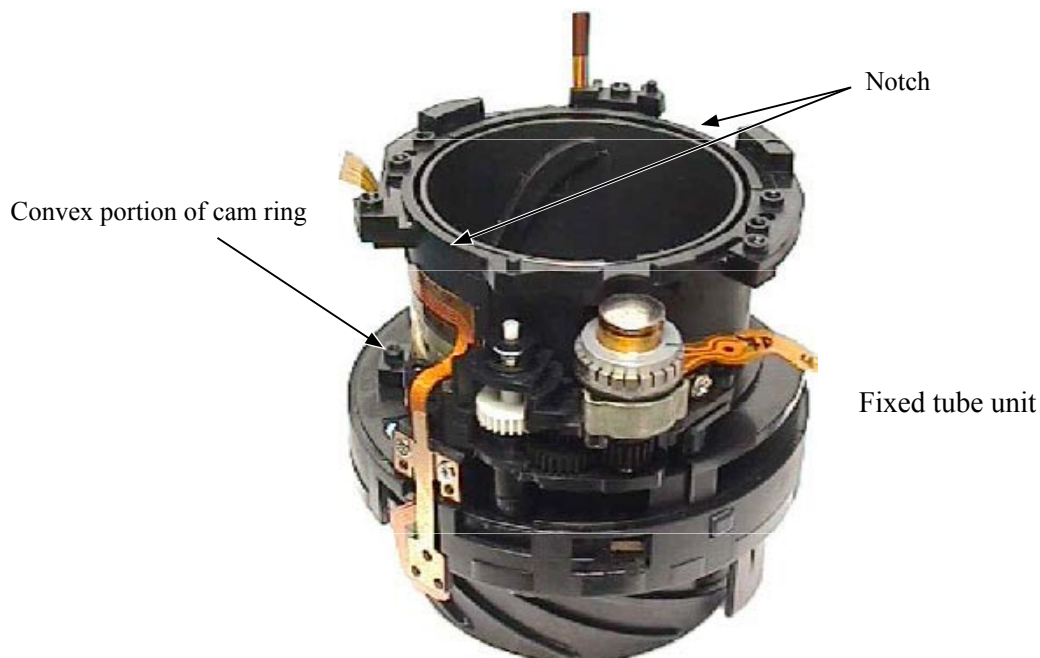
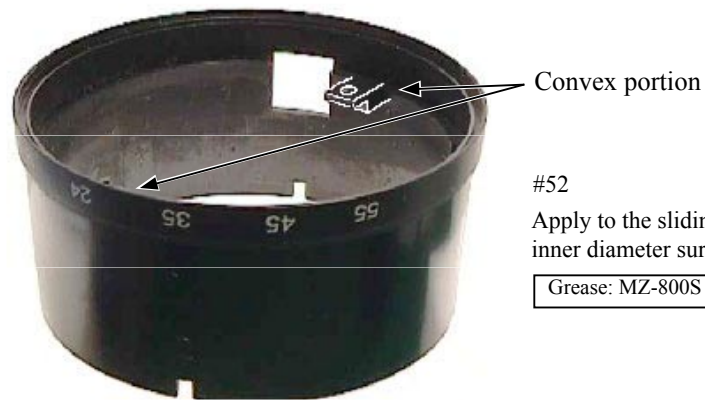

- Fix the zoom ring (#52) with 2 screws (#102), and check the smoothness of the zoom ring's movement.

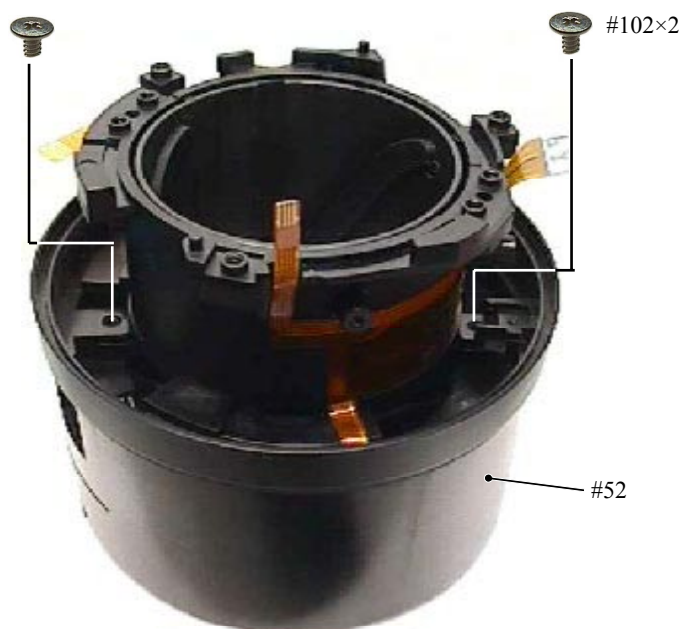

Filter ring unit

- ① Turn the zoom ring in the direction of the arrow (TELE-side).
- ② While lifting the clutch gear, turn the key of the focus ring all the way in the direction of the arrow.
- ③ Align the reference line of the filter ring unit (#B20) with "A" part of the helicoid ring, and turn the filter ring until it clicks.

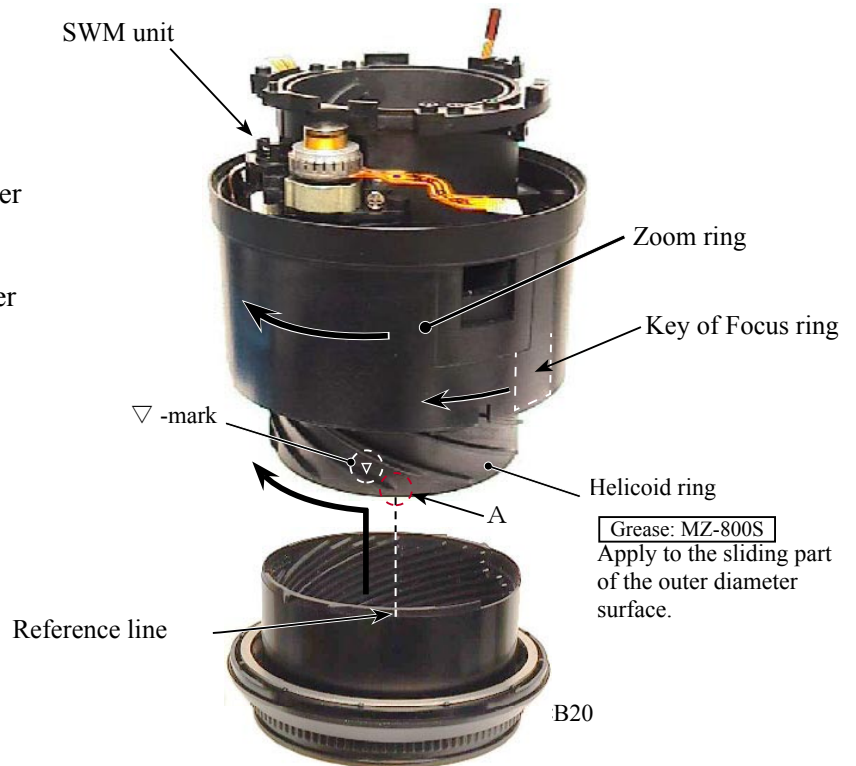

Inspection and adjustment of output waveform of MR encoder

• **【Attachment diagram】**

Self-made tool that is created with the main PCB of AF-S 24-85

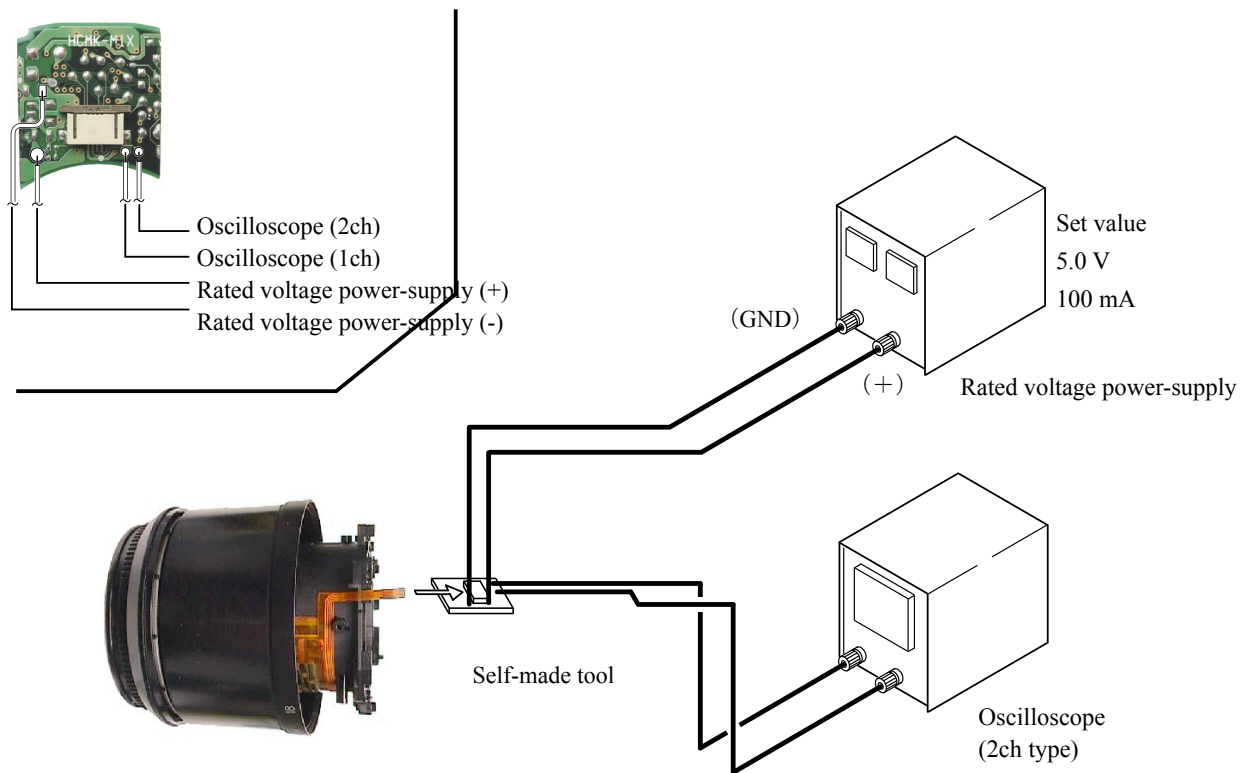

• How to inspect and adjust:

- ① Confirm that the electric current and voltage of the connected rated voltage power-supply are set values, then turn it ON.
- ② Set the oscilloscope. While holding the white gear of the SWM unit with tweezers, etc, up towards the bayonet side, turn the focus ring manually.

Note: The waveform varies according to the rotational speed of the focus ring. So change "Time/Div" setting accordingly.

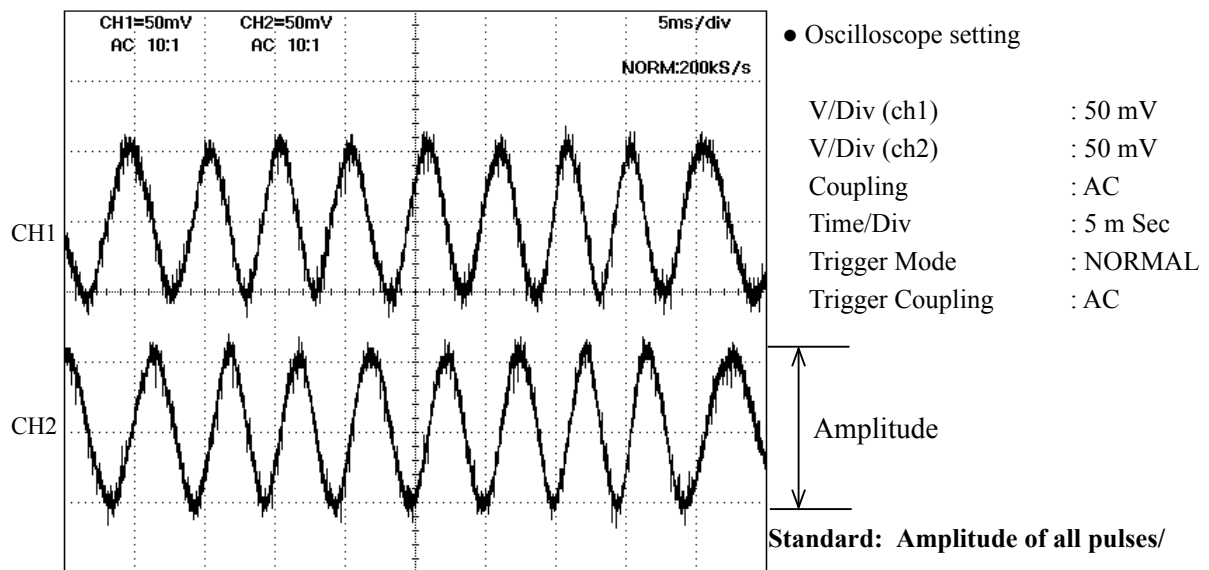

Fig.1

Note: Check the waveform by moving the focus ring back and forth from the infinity-end to the close-end positions entirely.

- ③ In case large waveform-noise (as shown in Fig. 1) is detected, use the FILTER function.

How to set FILTER function (e.g. DL1540 manufactured by YOKOGAWA)

1. Press the FILTER button.
2. Select "Smooth" of the menu on screen and turn it ON.

- ⑥ In case the amplitude is small, disassemble up to the stage of the zoom ring. Then if the deformation is detected in the MR head, correct the deform of the MR head. On the other hand, if such correction is impossible or no deformation is detected, replace the MR unit. (Fig.2)

Note: When adjustments are made, prevent the magnetic surface and MR head from touching the magnetized driver bit. Otherwise, the magnetic data may be damaged.

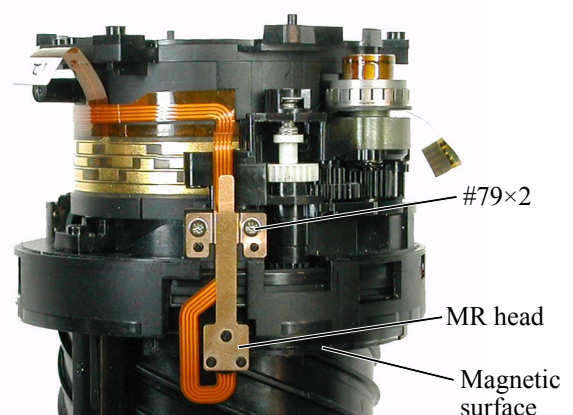

Fig.2

< Ref. >

- As shown in Fig. 1, if the amplitude of only either CH1 or CH2 is small, one of the 2 screws (#218) may be loosened, so check for it. If this is not the case, the MR head may malfunction, so replace the MR holder unit and make a readjustment.

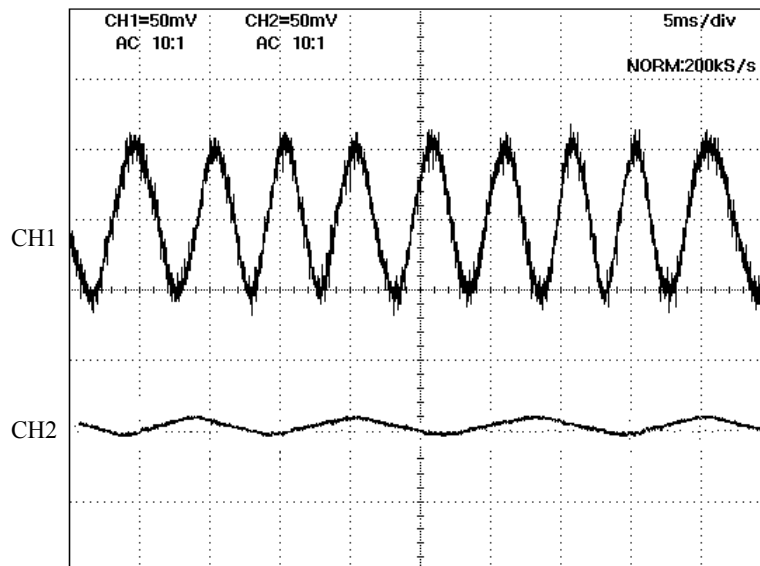

Fig.1

- As shown in Fig. 2, if the amplitude partially drops between the infinity and the close-distance, the magnetic data of the tape may be damaged. So replace the main fixed tube unit and make a readjustment. Replacing only the magnetic surface is impossible.

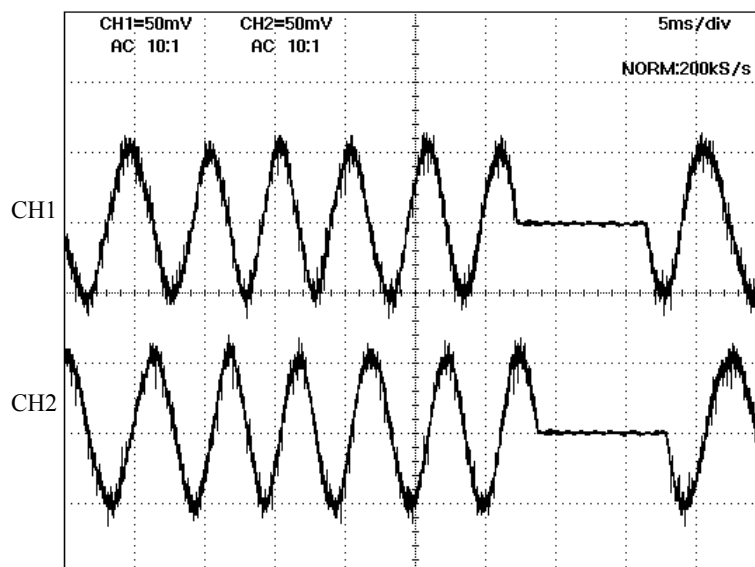
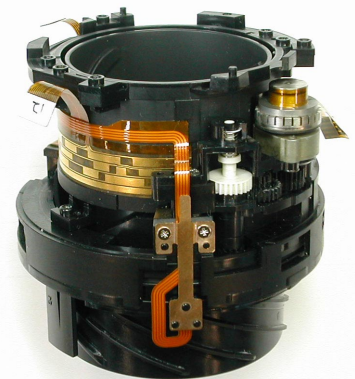

Fig.2

Fixed tube unit



- ⑦ Turn off the rated voltage power-supply.

- While pressing the zoom aperture ring on the zoom ring (#52), attach the polyester tape (#77) to cover the boundary line of the entire circumference of the 2 rings.



Zoom brush unit

- Assemble the zoom brush unit (#B8) into the zoom ring (#52).

Note: In order to prevent the brush from being bent when assembled, use the Z-brush insertion sheet (J11316) and assemble the zoom brush unit (#B8).



Contact unit

- Valley fold the FPC of the contact unit (#B6) with fingers to crease it. Then attach the contact unit to the fixed tube.

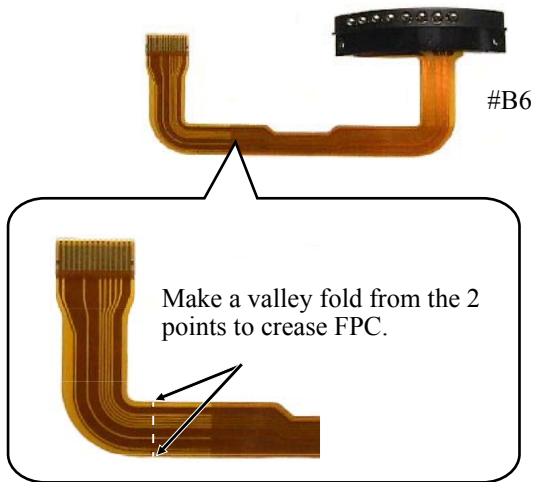

Align the FPC-mark with the edge of the fixed tube.

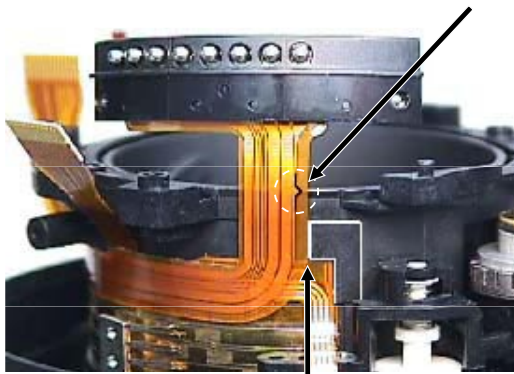

Surface for positioning

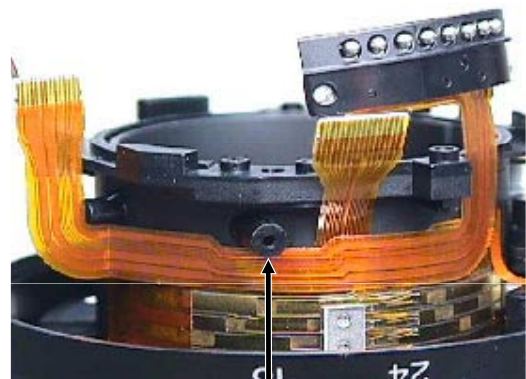

Surface for positioning

Main PCB unit

- After soldering the lead wire (#1131) on the main PCB unit (#B1001), pass the wire through the hole of the PCB.

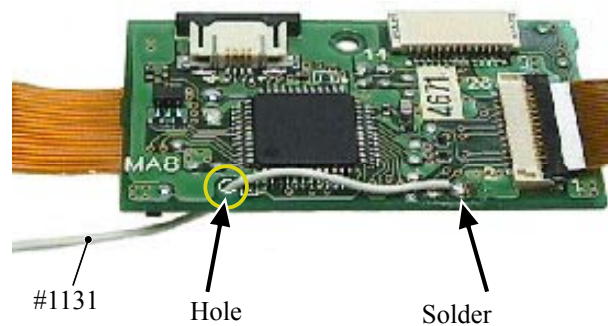

M/A change SW unit

- Solder 2 wires of the M/A change SW unit (#B22) on the main PCB unit (#B1001).

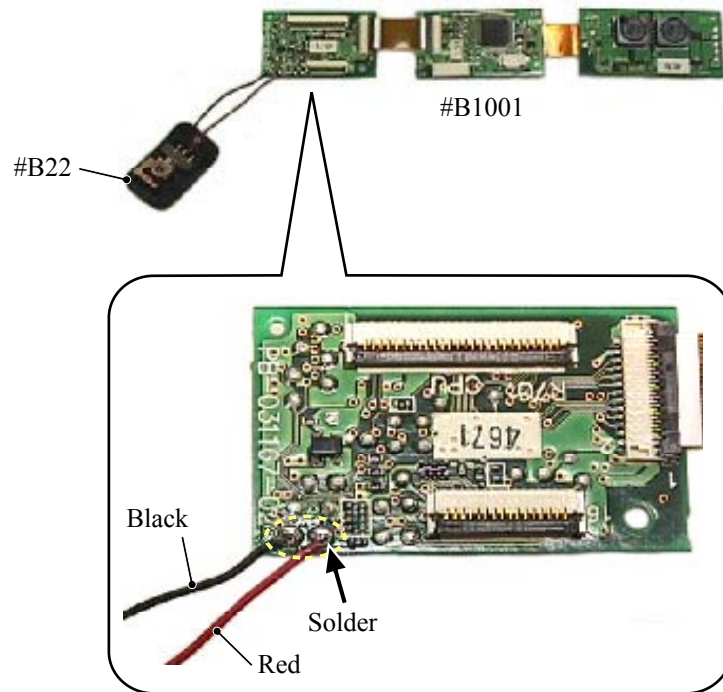

- Be sure to place the main PCB unit (#B1001) on the surface for positioning of the fixed tube, then fix it with 3 screws (#89×3).

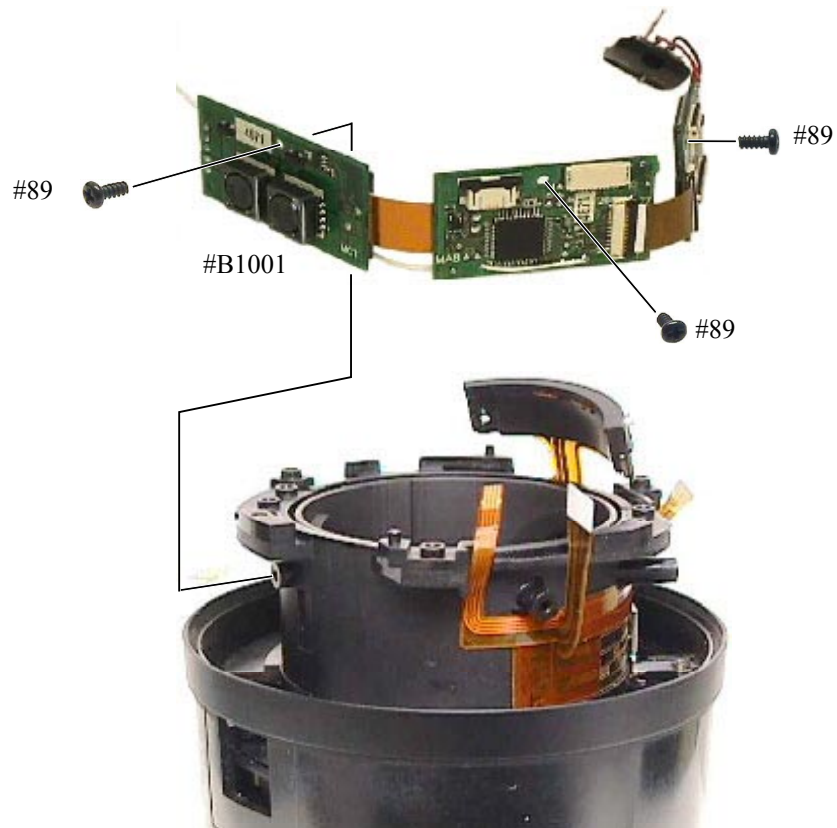

- Insert the zoom/distance FPC into the connector of the main PCB unit (#B1001) to connect it.

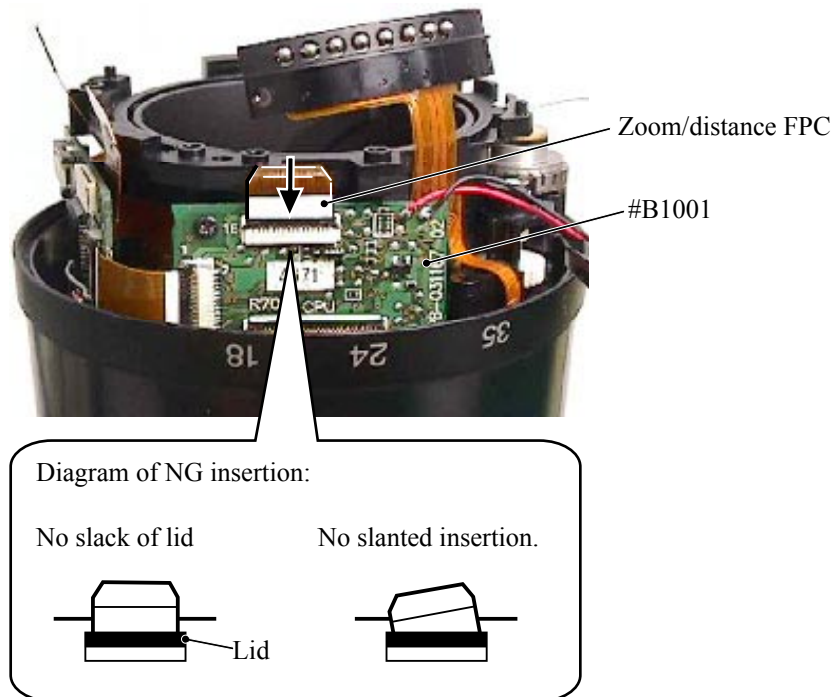

- Insert the contact unit (#B6) and GMR unit (#B7) into the connector of the main PCB unit (#B1001) to connect them.

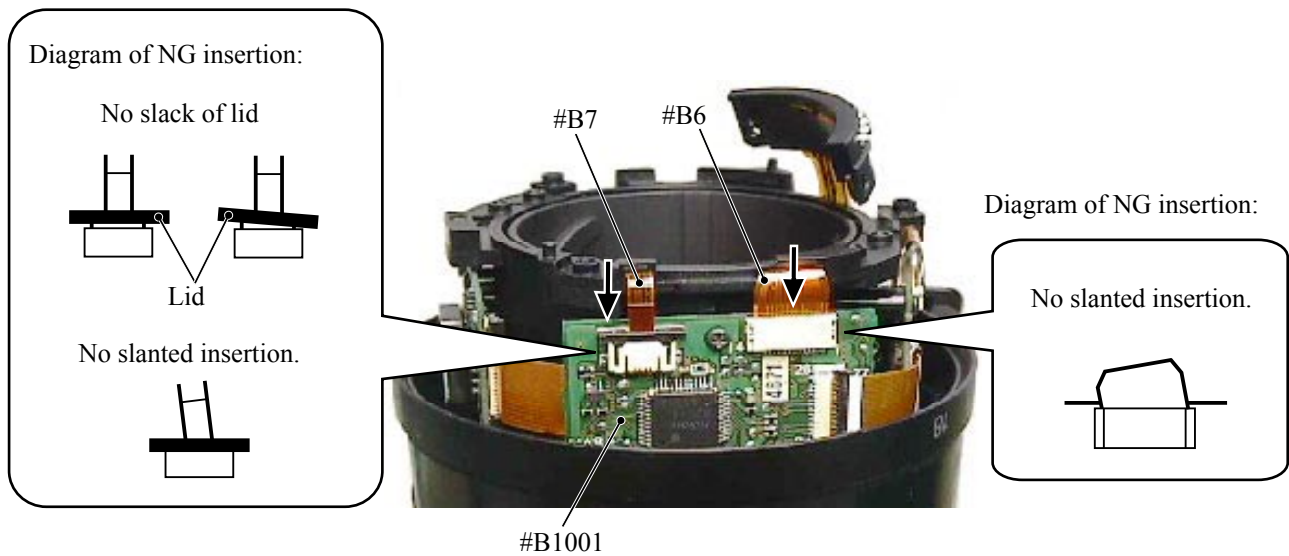

- Insert the SWM unit (#B501) into the connector of the main PCB unit (#B1001) to connect it.

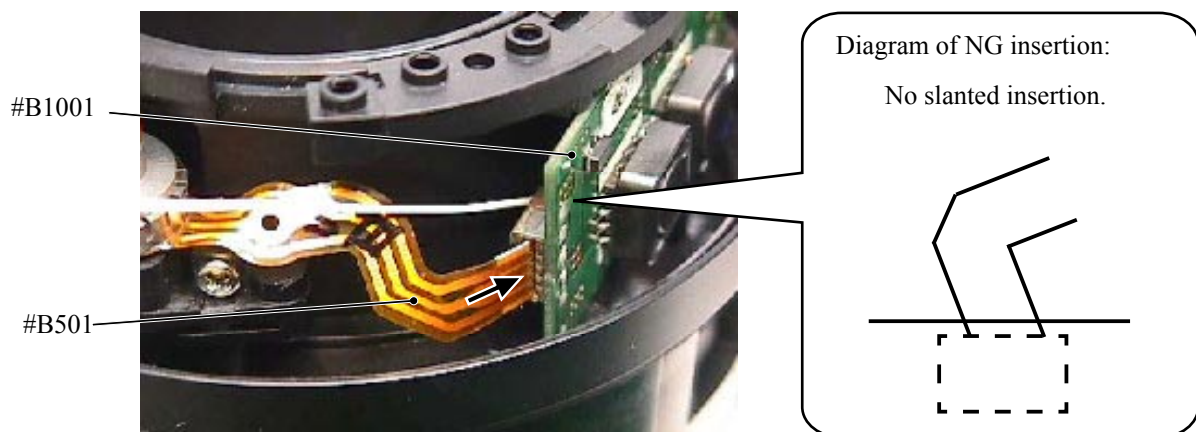

Rear fixed tube

- Set the M/A change SW unit (#B22) to "A" mode. Pass this unit through the window of the rear fixed tube (#57) and assemble them.

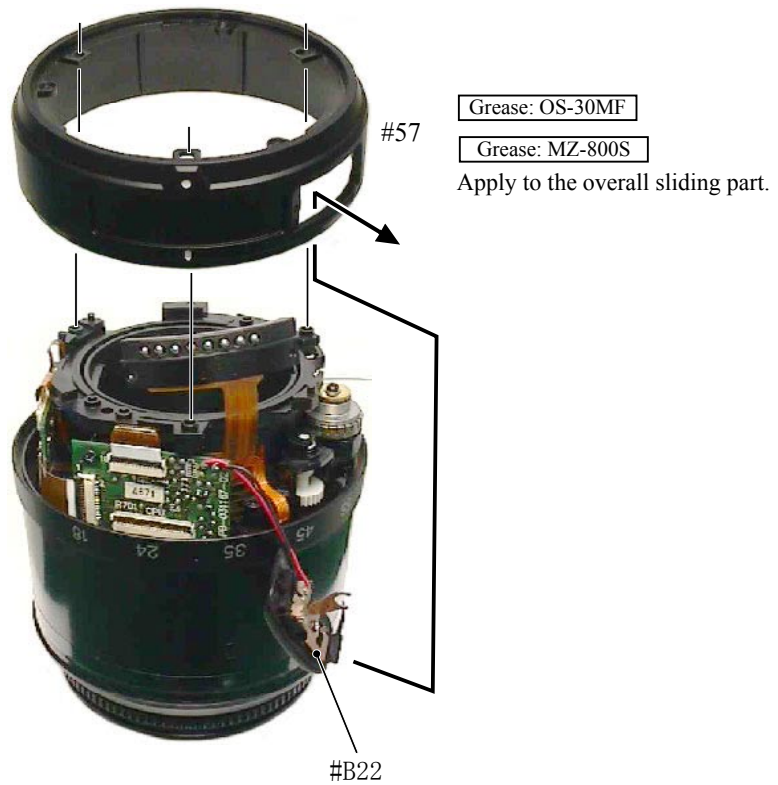

2nd lens group

- Set the zoom ring (#52) to WIDE side. Then assemble the 2nd lens group (#B24) into it by aligning convex portions with the concave portions of #B24.



Straight key unit

- After applying the grease to the straight key unit A (#B25A) and straight key unit B (#B25B), fix 4 screws (#86) by aligning setscrew holes and key grooves of the fixed tube unit.

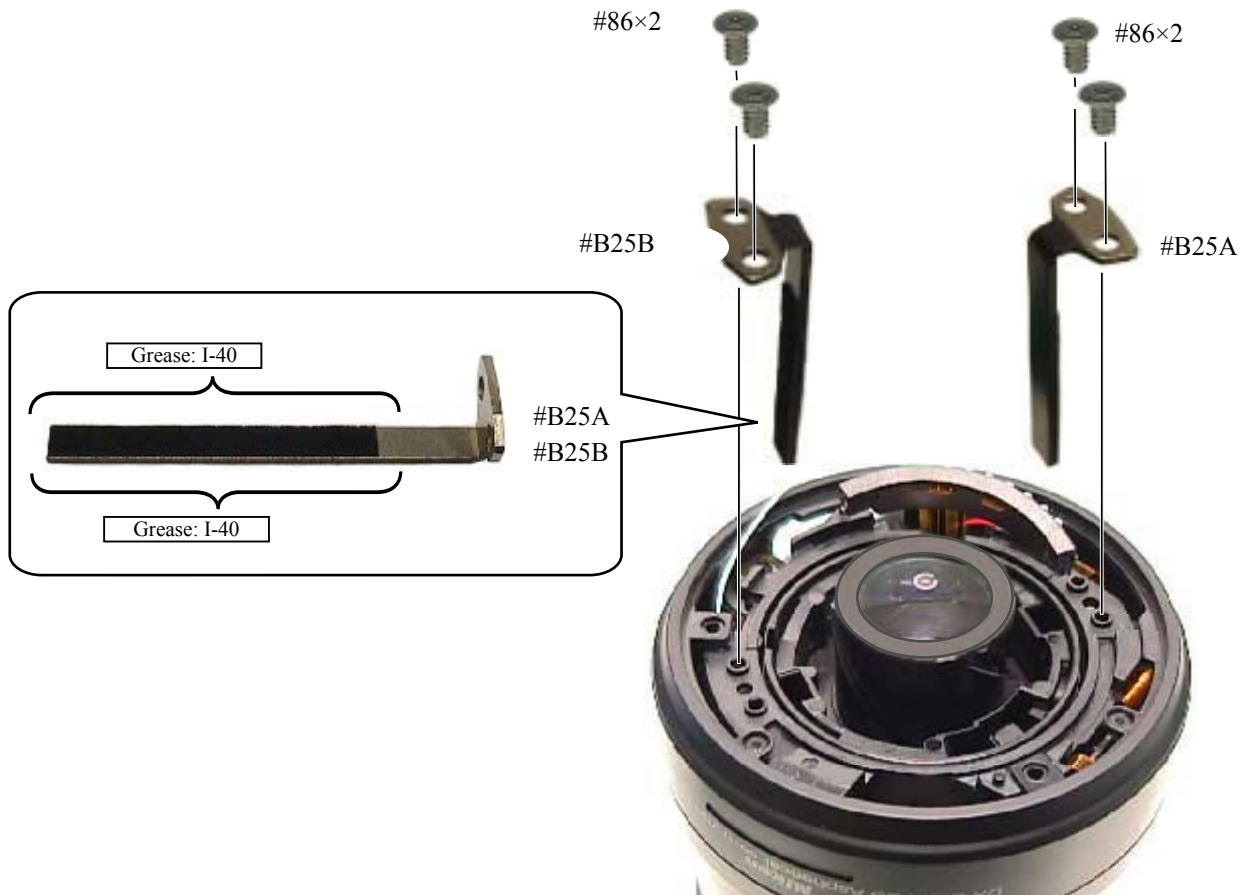

Flare cutter

- Align 3 cams of the 2nd lens group (#B24) with 3 convex portions of the flare cutter (#46) to assemble them. Then put the key part into the key groove of the cam tube.

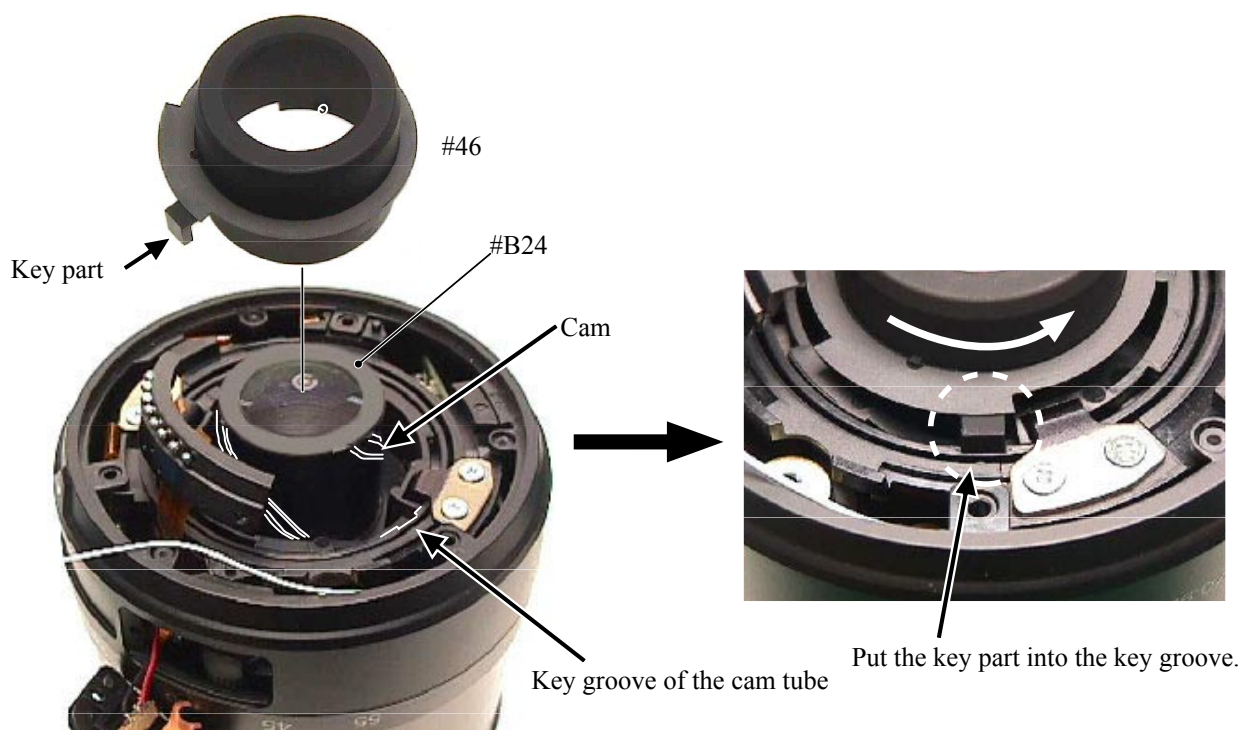

Washers

- Fix the washers (#101A ~ J×n).

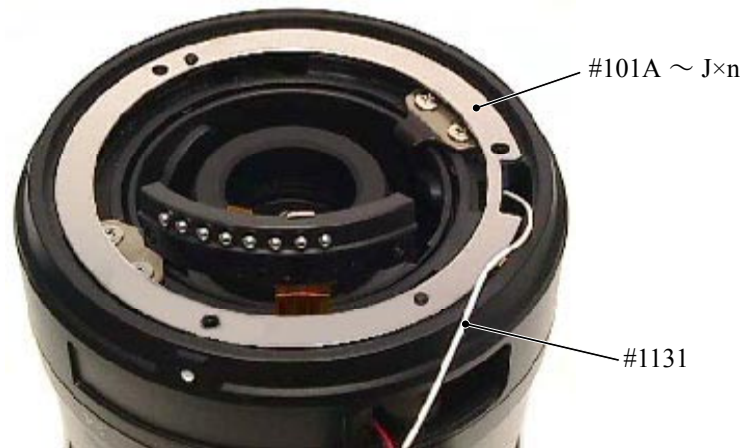

Bayonet mount unit

- After applying the grease to the lever of the bayonet mount unit (#B27), solder the lead wire (#1131) and fix 3 screws (#78) to assemble.

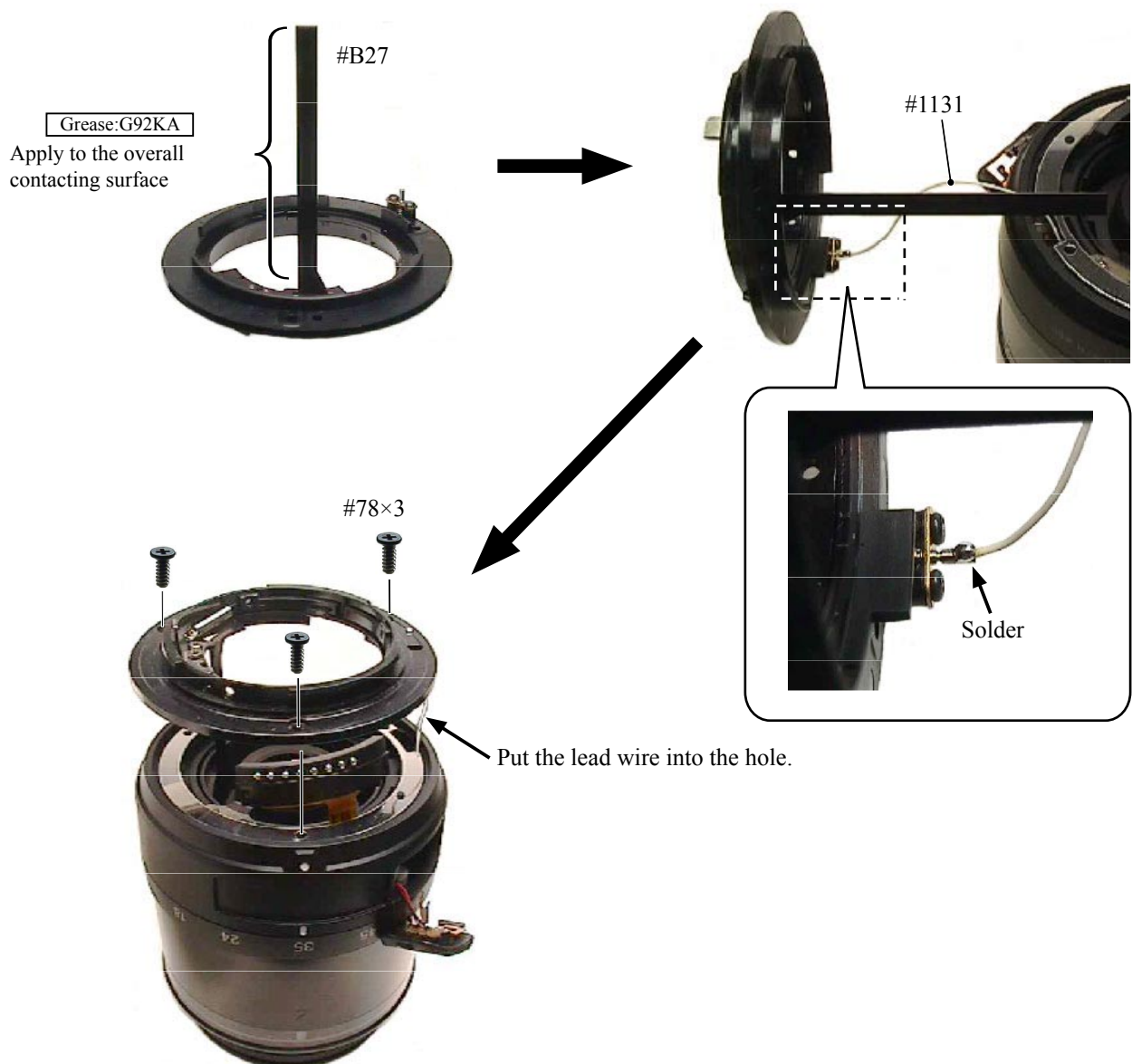

Ground line continuity check

- Check (electric) continuity of the ground line from the GND pin of the bayonet mount to the M/A change SW unit (#B22).

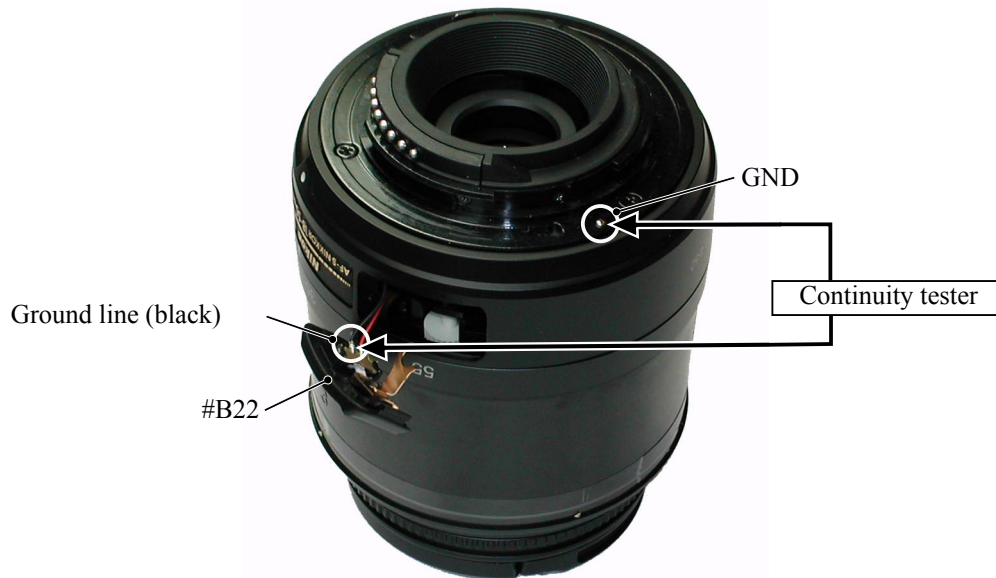

Attachment of M/A change SW unit

- Attach the M/A change SW unit (#B22) with the screw (#155).



Distance brush hole-covering plate

- Assemble the distance brush hole-covering plate (#103) into the zoom ring (#52), and attach the polyester tape.

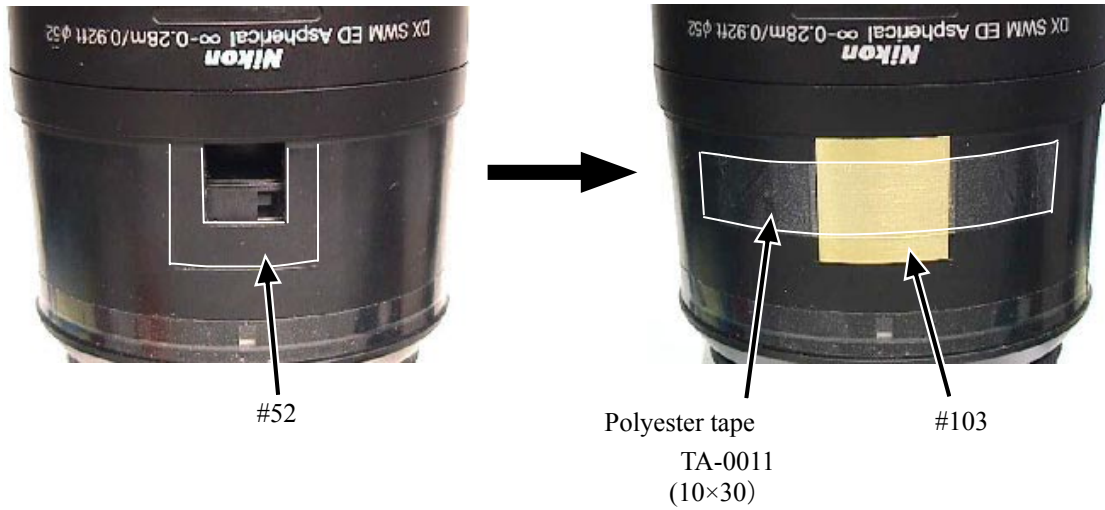

1st lens group

- Put the 1st lens group (#B1) and washers (#100A ~ I×n) by fitting their holes into the pins of the 1st lens-group assembling tool (J11315), and assemble them into the filter ring (#B20). Then fix 4 screws (#111).

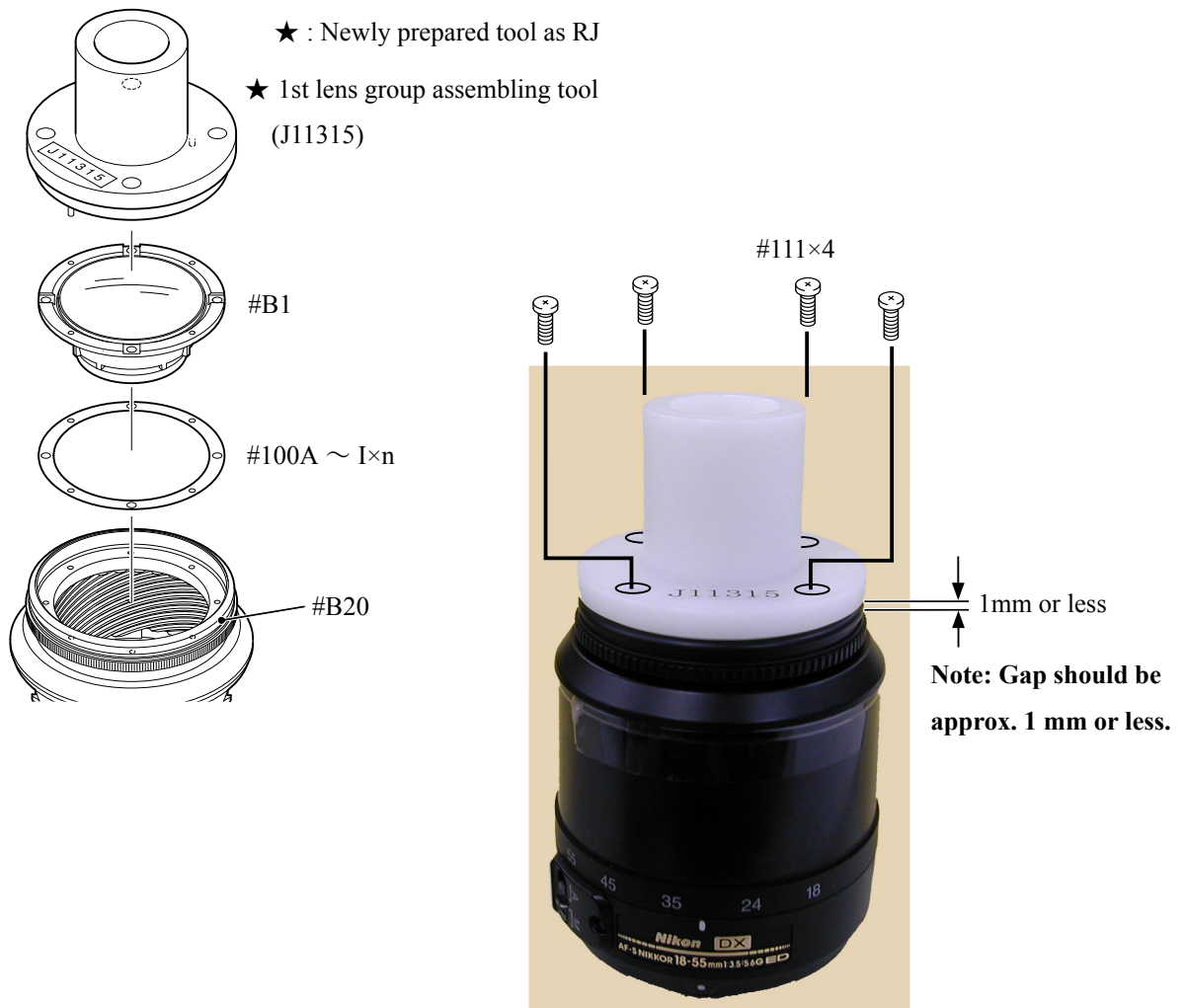

Adjustment (Division) of Focus movement (T, W)

1. Turn the focus ring all the way to the infinity-end.
2. Fix the aperture lever so that the aperture becomes full.
3. Read each value of WIDE and TELE sides.
4. Calculate as follows:

$$(A - B) \div 2.8 = C$$

A = Value at TELE side
 B = Value at WIDE side
 C = Adjustment amount (mm) of the washer (#100) of the 1st lens group

5. Adjust the washer (#100) by increasing/decreasing by the above value of C. If C is plus, increase the thickness of it, while it is minus, decrease the thickness of it. (ref. Page A16)

Note: When the washer (#100) is put, place a thin washer between thick washers.

Adjustment of F.F.D (Back focus)

1. Turn the focus ring all the way to the infinity-end.
2. Fix the aperture lever so that the aperture becomes wide open.
3. Read the value of Wide or Tele side.
4. Remove the bayonet mount.
5. Adjust the washer (#101) by increasing/decreasing by the difference from the standard value. If the difference is plus, increase the thickness of it, while it is minus, decrease the thickness of it. (ref. Page A14)

Focal length (f)	Standard (mm)
18 mm	+ 0.18 ~ + 0.33
35 mm	+ 0.85 ~ + 1.35
55 mm	+ 2.12 ~ + 3.04

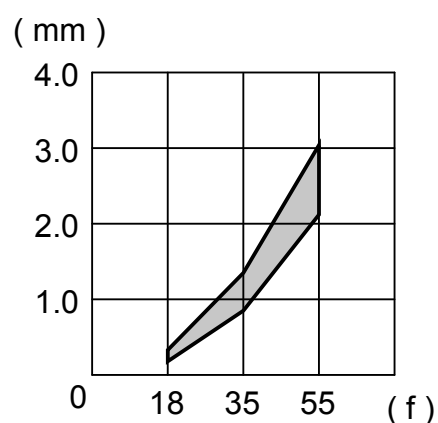

Aperture diameter adjustment

- ① Mount the tool (J18004-1) and check the aperture diameter.

Standard: Full aperture

- ② In case it is out of standard, adjust the position of the aperture lever (#23) by loosening 2 screws (#93).

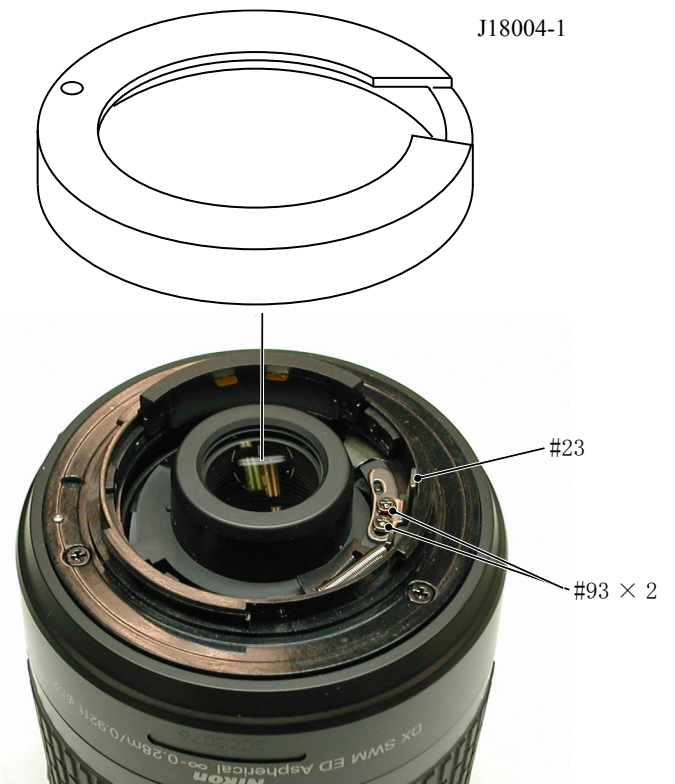

Attachment of Contact unit

- Fix the contact unit on the bayonet mount unit (#B27) with 2 screws (#67).



Preparation for inspection & adjustment of main PCB

- In case of replacing the main PCB, SWM unit or MR encoder unit, be sure to make the necessary adjustments as follows:

1. Adjustments

- Adjust the MR duty
- Adjust the driving frequency and motor control (including Focus preset adjustment)

2. Equipment and tools to be required

- Single output rated voltage power supply: 1 unit (6.0V 3.0A)
 - Oscilloscope: 1 unit For adjusting the MR duty, the driving frequency and motor control
 - AF-I communication box (J15306-1): 1 unit
 - AF-I communication adapter (J15307): 1 unit
- When the main PCB is replaced, be sure to perform “3. READING AND REWRITING OF EEPROM DATA” then “3. WRITING OF THE FIXED VALUES”.

AF-S 18-55 inspection and adjustment program (J18378)

The below hardware requirements are necessary for installing the program on a computer.

Ensure them before installation.

PC	IBM PC/AT compatible
OS	Windows XP Home Edition, Windows XP Professional, Windows 2000, Windows Millennium Edition (Me), Windows 98 Second Edition (SE), Windows 98,
CPU	Pentium II 266MHz ~ Pentium IV 2GHz
RAM (Memory)	32MB or more
HD	6 MB-or-more free space is necessary when installation
Monitor resolution	800×600 or more pixels
Interface	Serial interface ※ USB interface cannot be used.

As long as the above requirements are met, either desktop or notebook PC is available.

【System configuration】

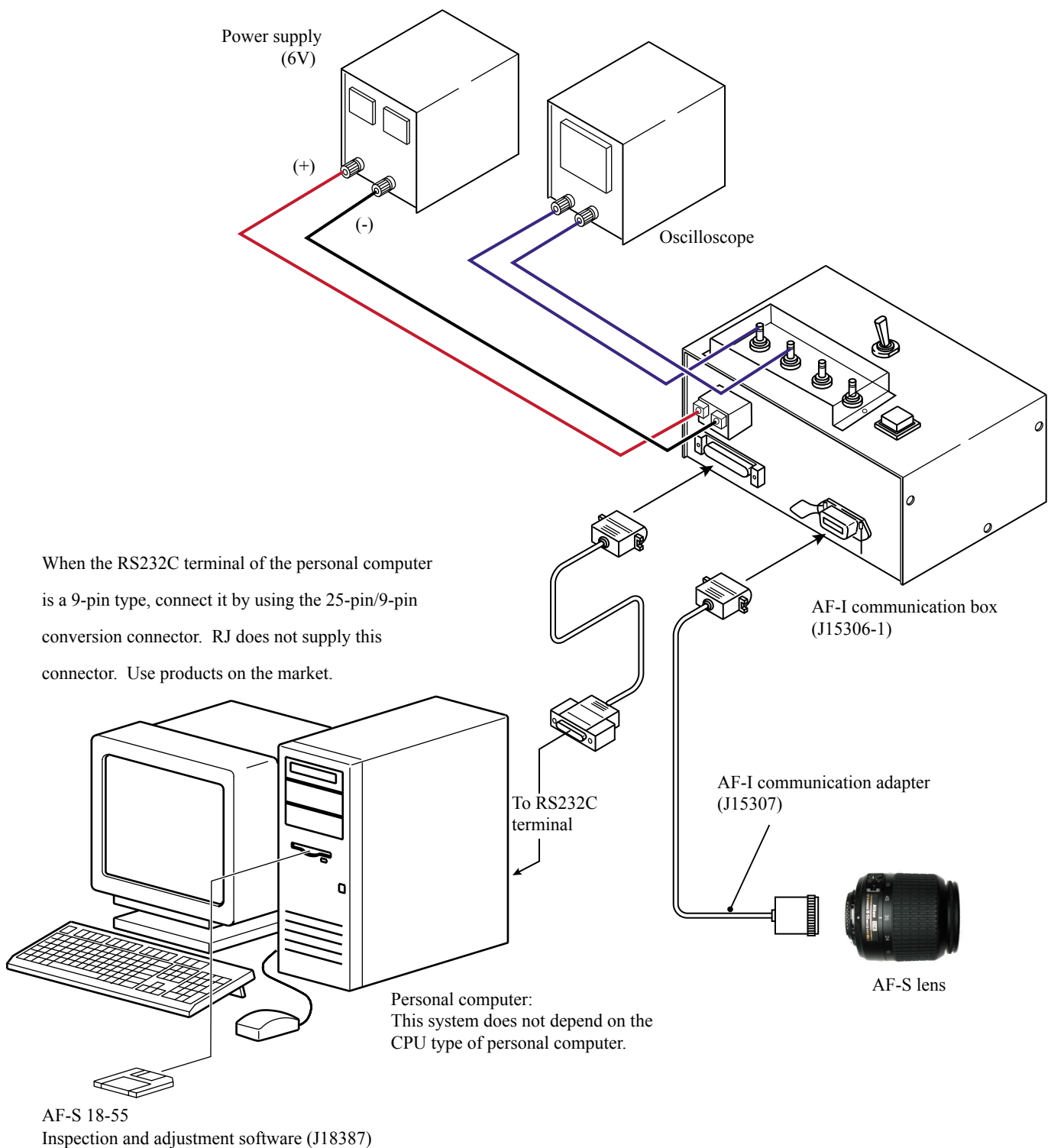

Adjustment of MR duty

- In case of replacing the main PCB, SWM unit and MR encoder unit, be sure to make adjustments.
- In case of replacing the main PCB, be sure to perform [READING AND REWRITING OF EEPROM DATA.] then [3.WRITING THE FIXED VALUES.]

How to adjust

- ① Make sure that the electric current and voltage of the connected rated voltage power supply are set to the set values, which are instructed on the PC screen. Then, turn the rated voltage power supply ON.
- ② Select "1. MR DUTY ADJUSTMENT" in the menu of the AF-S 18-55 inspection program.
- ③ The confirmation screen for writing the fixed values in EEPROM appears. Select the appropriate item.
- ④ Following the instruction on the screen, rotate the MF ring slowly by hand in the direction from the infinity to the close distance position. Make sure that the waveform on the oscilloscope has duty 50% and stop the MF ring at the close distance-end.

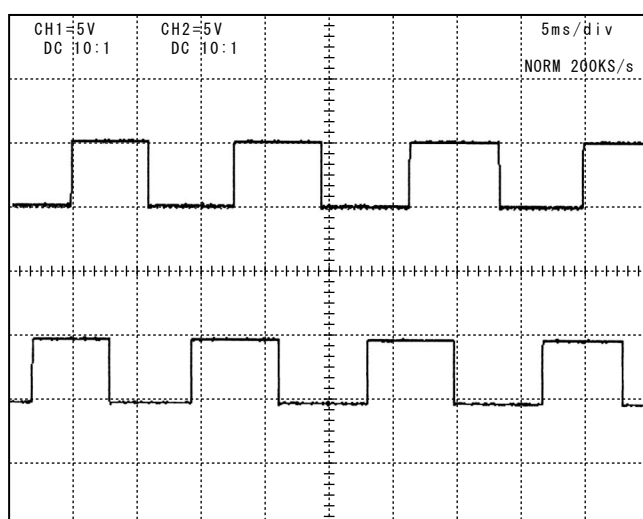

● Setting of oscilloscope

V/Div (CH1)	: 5V
V/Div (CH2)	: 5V
Coupling	: DC
Time/Div	: 5 m Sec
Trigger Mode	: NORMAL
Trigger Coupling	: DC
Trigger Source	: CH 1
Trigger Position	: +4 div
Trigger Type	: EDGE
Trigger Level	: 2.5 V

- ⑤ Following the instruction on the screen, rotate the MF ring slowly by hand in the direction from the close distance to the infinity position. Make sure that the waveform on the oscilloscope has duty 50% and stop the MF ring at the infinity-end.

Note : In case the waveform from infinity to close distance position or vice versa does not have duty 50%, repeat "INSPECTION AND ADJUSTMENT OF THE MR ENCODER OUTPUT WAVEFORM" on Page A5.

Standard H : L = 100 : 150 ~ 150 : 100 (50% ±10.0%)

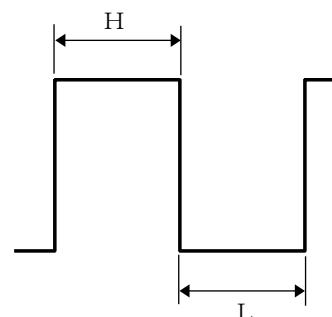

Adjustment of Driving frequency and Motor control

● In case of replacing the main PCB, SWM unit and MR encoder unit, be sure to make adjustments.

- ① The method of connection of the rated voltage power supply and measuring tools is the same as "ADJUSTMENT OF MR DUTY".
- ② Make sure that the electric current and voltage of the rated voltage power supply are set to the set values on the PC screen.
- ③ Turn the rated voltage power supply ON.
- ④ Select "2. ADJUSTMENT FOR DRIVING FREQUENCY & MOTOR CONTROL" in the menu of the AF-S DX18-55 inspection program. The lens automatically starts the driving of scanning.

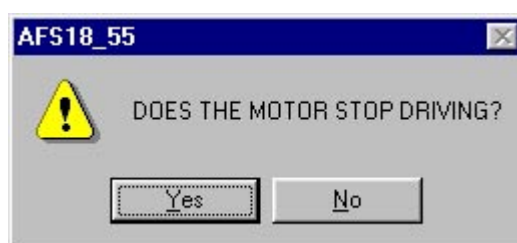

Fig.1

- ⑤ When the above Fig.1 is displayed, if the motor driving stops, select "Yes" to complete the adjustment. In case the motor does not stop driving, select "No" to make adjustments again. In case the motor does not stop driving even after the readjustments, adjust the MR duty again and repeat "ADJUSTMENT FOR DRIVING FREQUENCY & MOTOR CONTROL". If the adjustment is not successful in spite of the above, the SWM unit, fix-tube unit, or MR head unit may be defective.

Inspection of Lens operations

Check the lens operations by using a personal computer after assembling.

- Check by personal computer
 - Check by the following considerations:
 1. MR encoder operations
 - Drive the scanning of lens and check the total number of pulses.
 - In case the MR head of the MR encoder and the magnetic tape are misaligned, the number of pulses becomes out of standard.
 2. Lens-servo stop accuracy
 - Check the number of overrun/underrun pulses (deviation of the stop position from the target position) per the specified lens driving.
 - In case the irregularity of mechanical operations does not take place in the focus ring driving unit, the underrun tends to occur if it is heavy in the cam ring rotation of the MR encoder, while the overrun tends to occur if it is light in its rotation of the MR encoder.
 3. Lens-servo time
 - Check the servo time (from starting and stopping the servo) when driving the specified lens by using the oscilloscope.
 - In case the irregularity of mechanical operations does not take place in the focus ring driving unit, the servo-time tends to be long if it is heavy in the cam ring rotation of the MR encoder, while the servo-time tends to be short if it is light in its rotation of the MR encoder.
 4. Switches and lenses
 - Check the ON/OFF operations of switches and the operating condition of the distance encoder.
 - After inspections
 1. When the MR encoder operations are not up to the standard:
 - Readjust the MR duty. (ref. Page A26.)
 - In case the pulse is not up to the standard, adjust the output waveform of the MR encoder again. (ref. Page A5.)
 - In case the pulse meets the standard, replace the cam ring unit.
 2. When the lens-servo stop accuracy is not up to the standard:
 - Check the output waveform of the MR encoder. If it is normal, replace the fix-tube unit.
 3. When the lens-servo time is not up to the standard:
 - Readjust the driving frequency and motor control.
 - In case the lens-servo time is not up to the standard even after the readjustment, replace the fix-tube unit.
 4. When switches do not work properly:
 - Check the wiring state of the troubled switch or replace it.

- AF-S DX18-55 inspection program

- (1) Menu screen

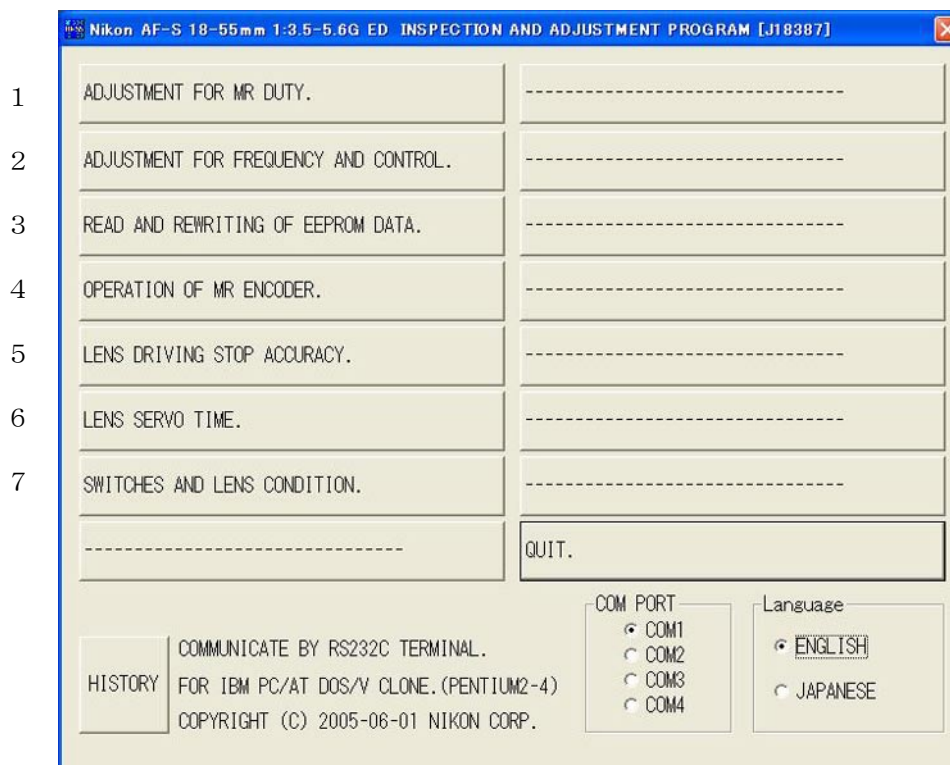

- Menu items

The items 1 and 2 are used for adjustments.

The item 3 is used for reading and writing EEPROM DATA.

The items 4~7 are used for inspections.

- Selection items

After selecting items screens appear, such as the lens selection, the focal length selection, the voltage setting, the inspection mode start.

The screens depend on the items. Follow the instructions of the personal computer.

- Initial driving

Drive scanning several times and stop at infinity-end.

(2) Inspection of MR encoder operations

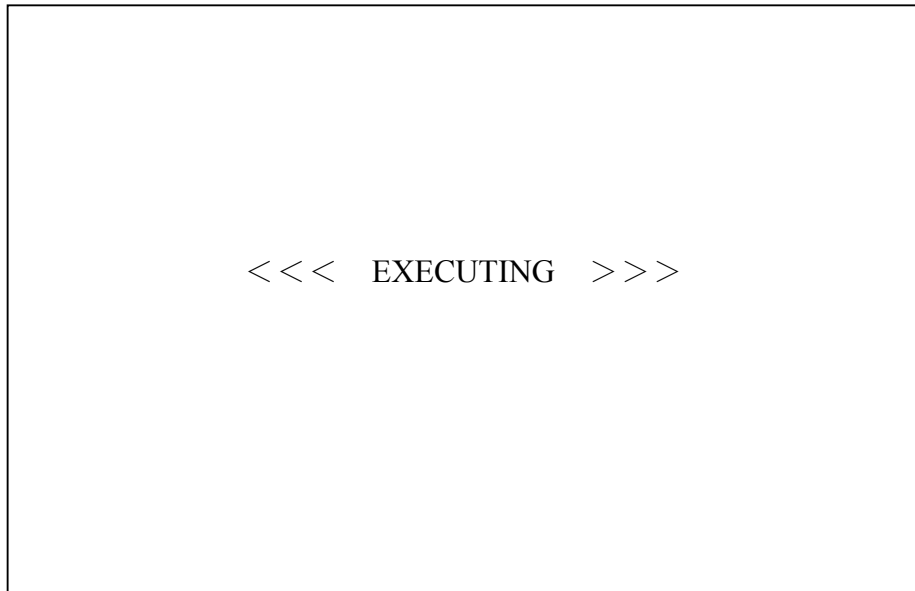

Caution : If the MF ring is rotated while the lens scanning is driven, the pulse shows an abnormal value.
Do NOT touch the MF ring during operations.
Make inspections at the 5 positions as below.

When the inspection ends, the result of the next page appears.

The difference in pulse before and after the inspection must be within the standard.

< Standard > Total pulses : 1863 ± 100 PULSE(S)

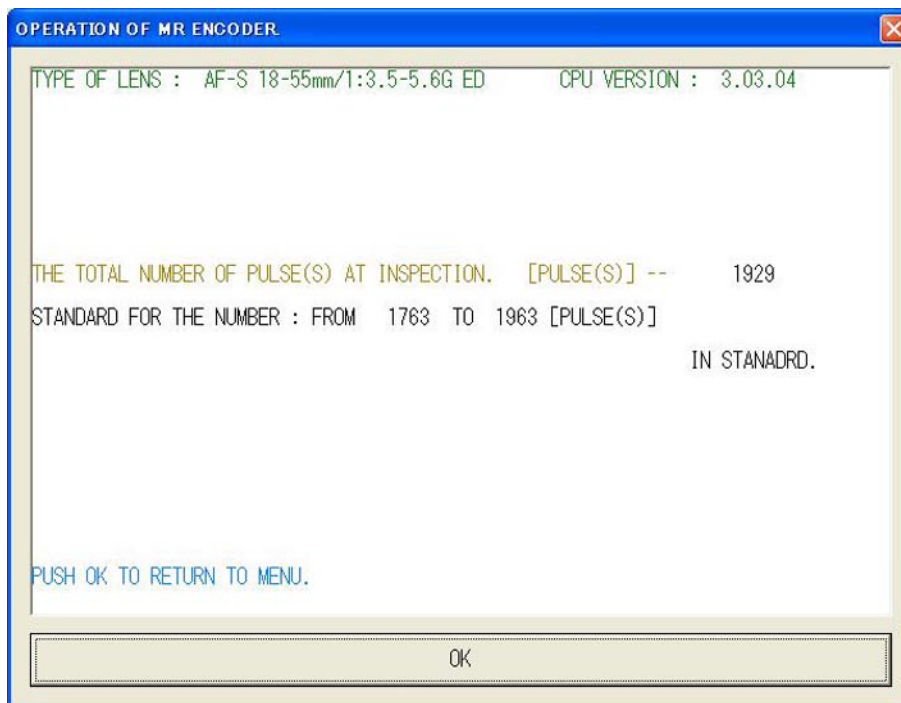

(3) Inspection of lens-servo stop accuracy

- ① Make this inspection on both focal length 18mm (W) and 55mm (T).
- ② If the lens stops while inspecting the lens-servo stop accuracy, select "3. ADJUST DELAY-TIME" of the below Fig.2, and input a figure between 0-1000 for the delay time (msec: millisecond) which prevents stopping the lens.

Note:

The value of "ADJUST DELAY-TIME" is set by the adjustment software. So, if the lens does not stop during the inspection of "LENS DRIVING STOP ACCURACY", any value can be input without problem.

However, the larger the value of "ADJUST DELAY-TIME" gets, the longer the inspection time becomes.

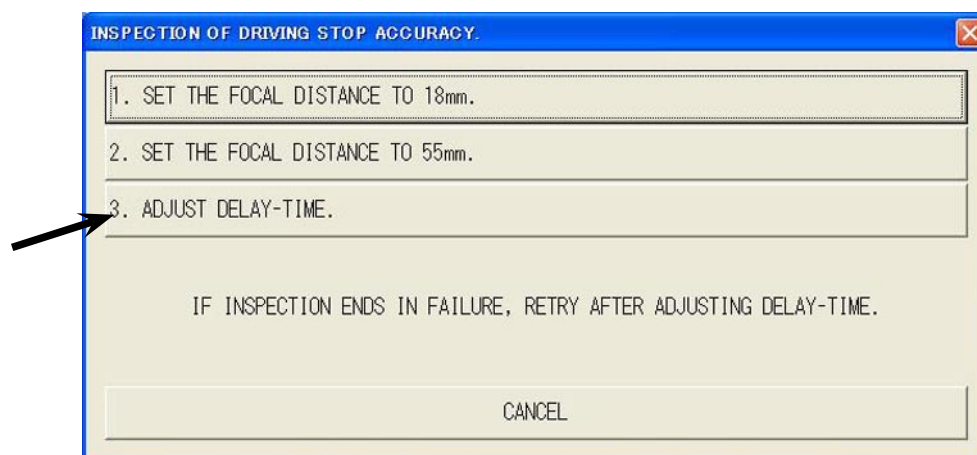
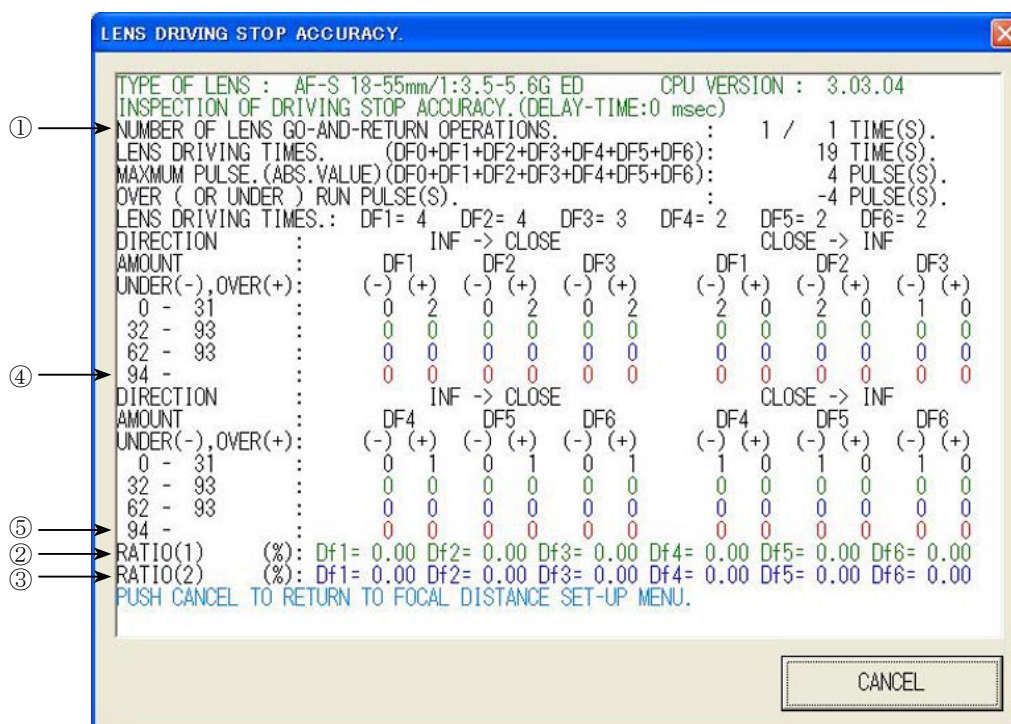

Fig.2





Caution : If the MF ring is rotated while the lens scanning is driven, the pulse shows an abnormal value. Do NOT touch the MF ring during operations.
During the lens driving, the above screen is displayed.

The number of overrun/underrun pulses must be within the standards after the lens back-and forth driving 5-motion ("1/1TIME (S)." in [1] of the display).

Standard RATIO (1) is 40% or less for Df1~Df6. ② of the screen

[Occurrence ratio of (W) 32-93/(T) 7-18 pulses]

RATIO (2) is 20% or less for Df1~Df6. ③ of the screen

[Occurrence ratio of (W) 62-93/(T) 12-18 pulses]

Occurrence of (W) 94/(T) 19 or more pulses is zero for Df1~Df6. ④ and ⑤ of the screen

[Only one occurrence indicates defective.]

※ "Df1~Df6" shows the lens driving amount.

(4) Inspection of lens-servo time

Make this inspection on both focal length 18mm (W) and 55mm (T).

SERVO AMOUNT.	STANDARD.
1. [Df1]	135ms OR LESS.
2. [Df2]	165ms OR LESS.
3. [Df3]	200ms OR LESS.
4. [Df4]	240ms OR LESS.
5. [Df5]	290ms OR LESS.
6. [Df6]	315ms OR LESS.
7. DRIVING TO INFINITY.	
8. DRIVING TO CLOSE.	
9. RETURNING TO FOCAL DISTANCE SET-UP MENU.	

Connect the probes of oscilloscope to E and H terminals of the AF-I communication box (J15306). Select the servo driving amount respectively. Each lens-servo drive time must be within the standard.

Caution : If the MF ring is rotated during inspections, the waveform shows an abnormal value. Do NOT touch the MF ring during inspections.

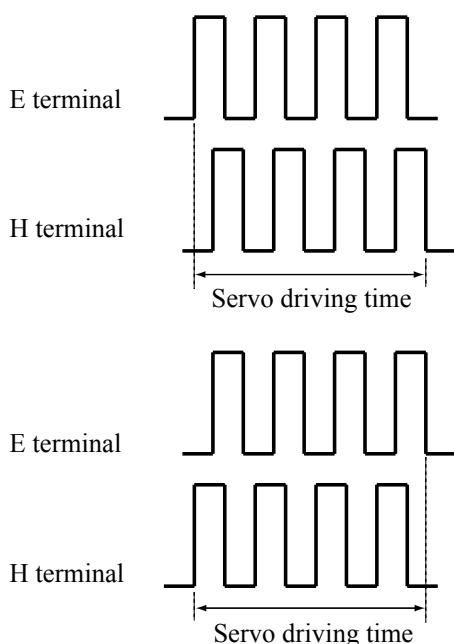

●Oscilloscope setting

- V/Div : 5V
- Coupling : DC
- Time/Div : 20 m Sec
- Trigger Mode : SGL (S)
- Trigger Coupling : DC
- Trigger Source : CH1

※ The waveforms of E and H terminals have the forms for going up for start and going down for start.

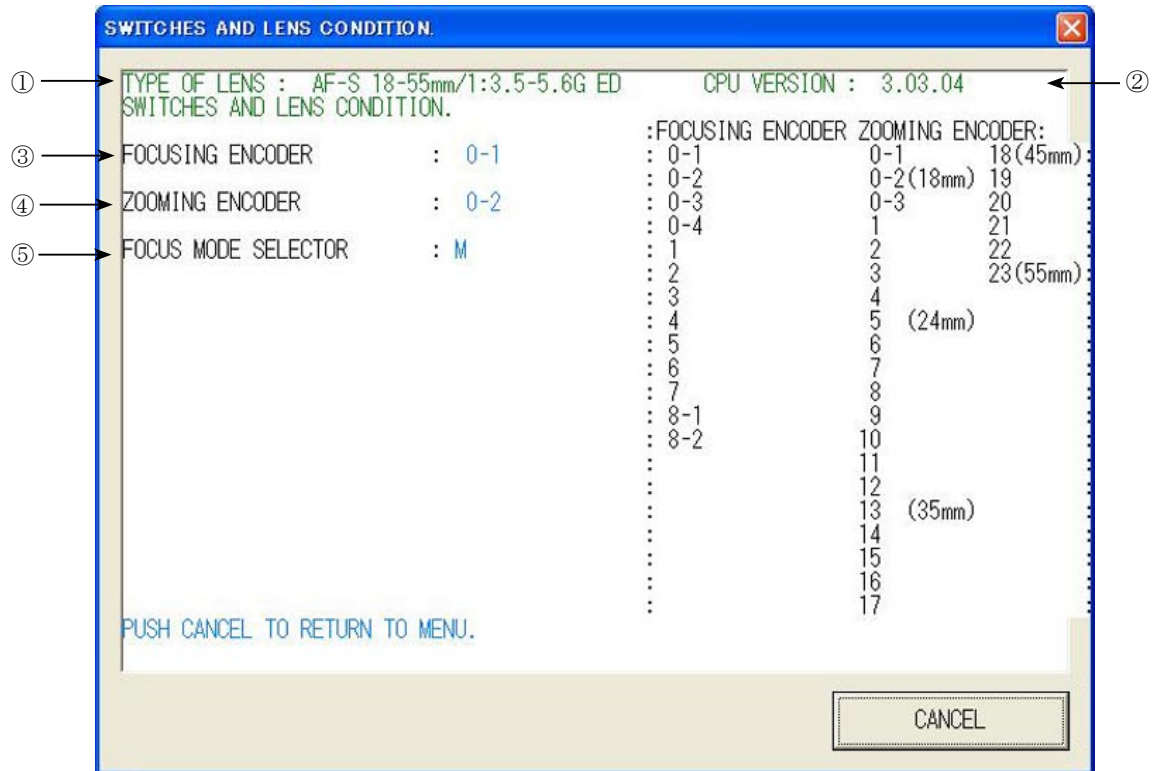

- ① Type of lens
- ② Version of CPU in the lens
- ③ Signals of the distance encoder
Value changes by turning the MF ring with "M" or M/A of the lens driving mode selector.
- ④ Position of the zoom encoder
(Value changes by turning the zoom ring)
- ⑤ lens driving mode selector SW

Necessary adjustment when replacing parts

Adjustments Parts to be replaced	Adjustment for MR duty (Necessary to write fixed value); driving frequency; motor control	Inspection & adjustment for MR encoder operations; lens-servo stop accuracy; lens-servo time; switches; lens condition
Main PCB unit	○	○
SWM unit	○	○
MR head unit	○	○
Fixed tube unit	○	○

Aberration compensation data writing adjustment

- This adjustment uses the software which calculates the aberration compensation data according to the feature of lens aberration and writes in EEPROM of the lens, in order to improve the accuracy of autofocus.

Note: This adjustment is necessary when the main PCB and/or each lens part (glass, lens chamber) is replaced or when each lens part is disassembled. Be sure to make this adjustment after completing inspecting and adjusting the main PCB.

(1) Preparation

- Test chart (Self-made tool: ref. Procedure for how to create it.)
- Tripod
- D100
- Personal computer
- USB cable (UC-E4)
- Adjustment software (LWM.exe : used for the lens optical alignment.)

(2) Procedure for how to create Test chart

- Photocopy the next page and cut out 1 target chart and 5 resolution charts.

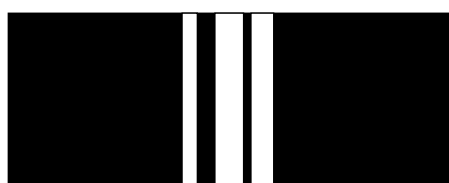

(Target chart)



(Resolution chart)

- As shown below, put each chart in position at the specified spacings.

Note: Only in the center, put the target chart on the central resolution chart.

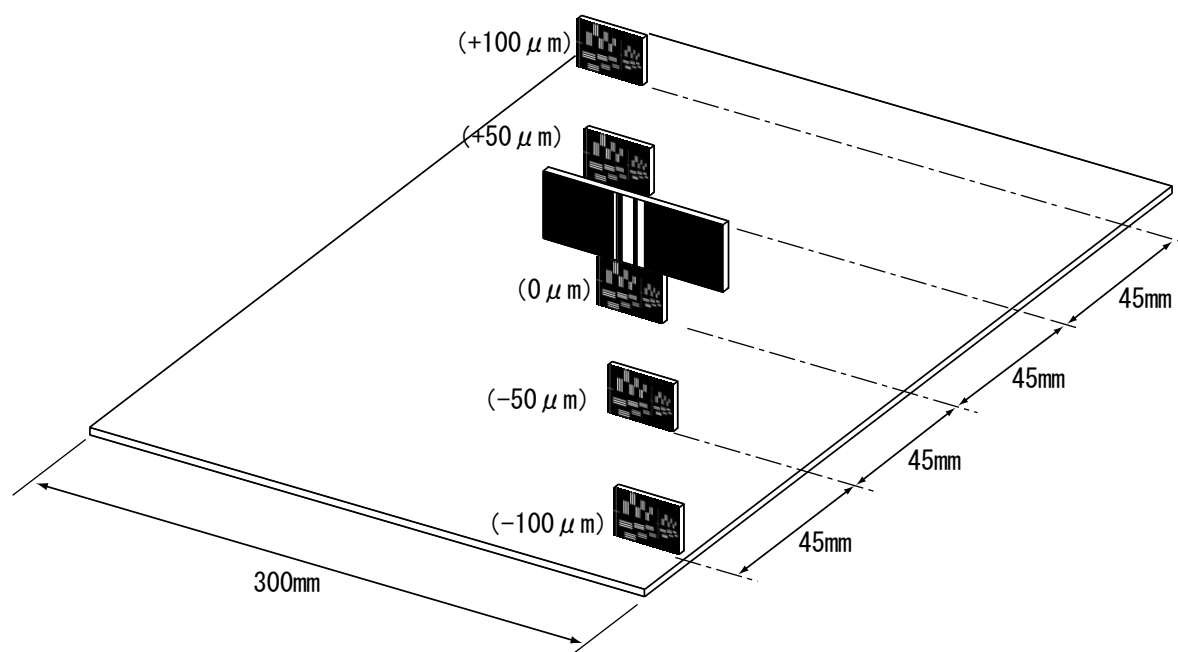

(Target chart)



(Resolution chart)

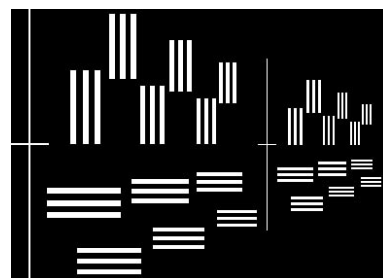
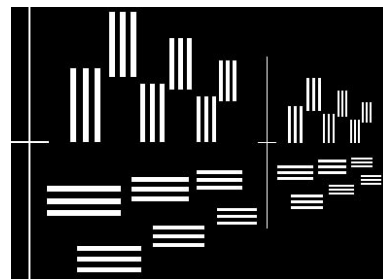
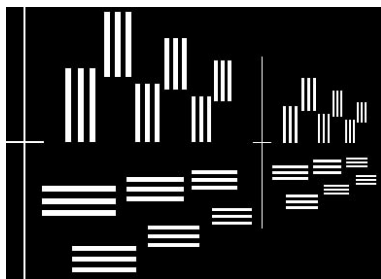

(3) Writing aberration compensation data

- ① Prepare a camera (D100). Set the "Exposure mode" to "A" for full aperture and "Focus mode" to "S".
On the shooting menu, set the "Image quality mode" to "FINE", "Image size" to "L", "WB" to "Preset", and "ISO" to "200".
- ② Set up the camera (D100), in which the lens to be inspected is fit, on the tripod. Set the focal length to 55 mm, and the distance between the test chart and camera (CCD face) to 2 m 20±2 cm.

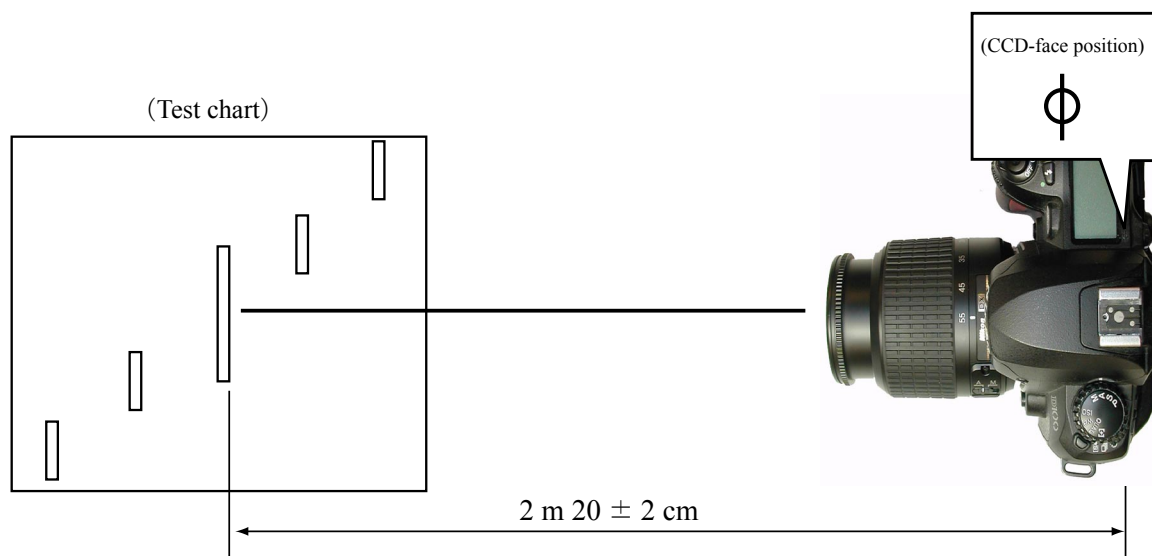

- ③ As shown below, bring the target chart in the center of focus area within viewfinder.

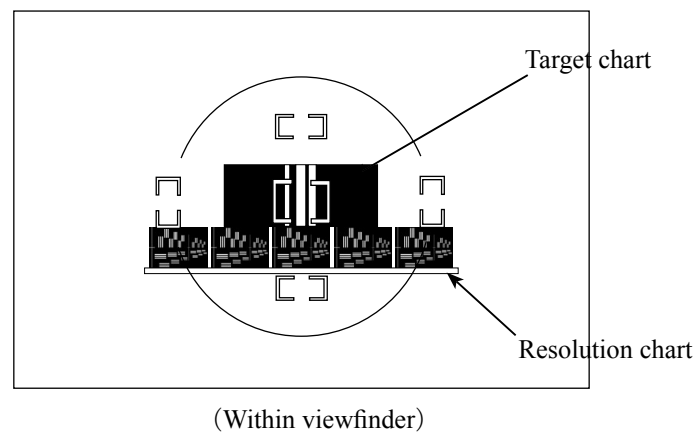

- ④ Connect the PC and camera via USB cable. (Camera setting: Mass storage)
- ⑤ Start the adjustment software (LWM.exe).

- ⑥ Select "AF-S DX18-55/3.5-5.6G" from "Target lens list", and click "OK" button.

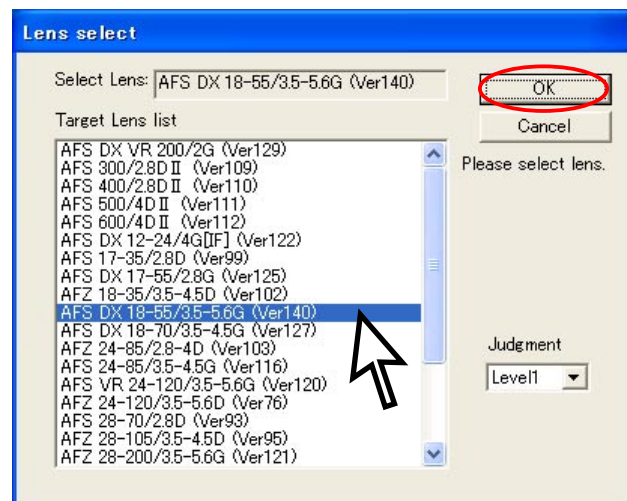

- ⑦ When "Next, Defocus rectify only" window appears, click "OK" button.

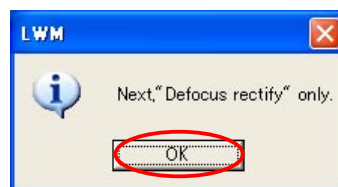

- ⑧ Click the "Defocus rectify..." button.

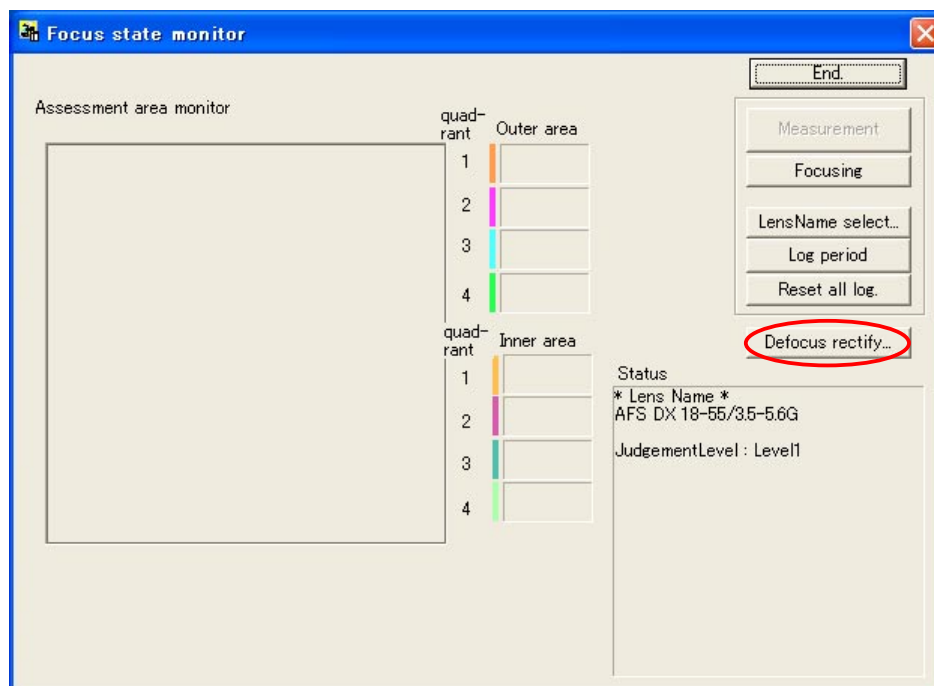

- ⑨ Click the "JPEG Shot" button.

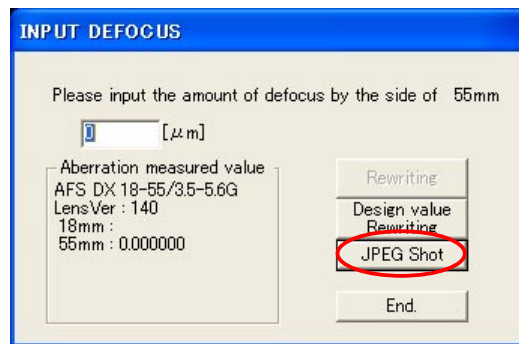

- ⑩ The shutter is released after the AF operation. The shot image is automatically displayed on the PC screen. Scale the image to 100% and check which chart is in focus of the 5 resolution charts.

Note: As for this lens, even if the aperture is fully open, the depth of field is so deep that when looking for the center of focus, compare 2 charts between which there are 2 or more charts.

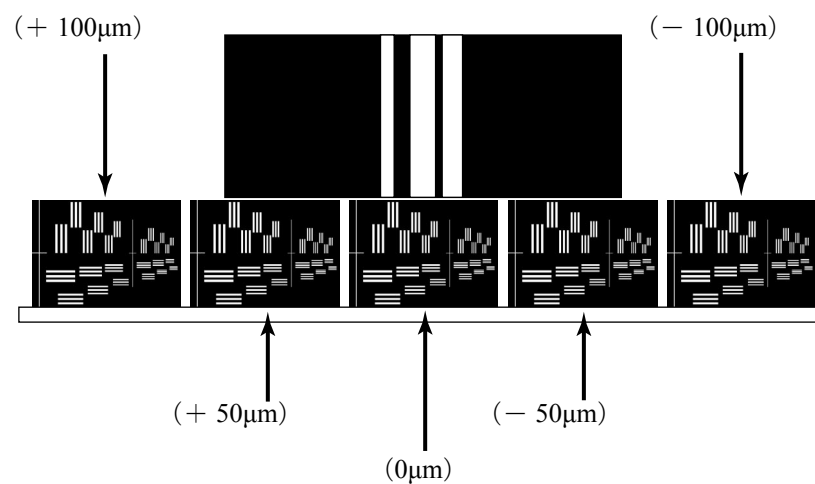

- ⑪ Input the value of the focused position into the entry field.
e.g. The below is the case when "+70μm" of the front focus side is in focus.

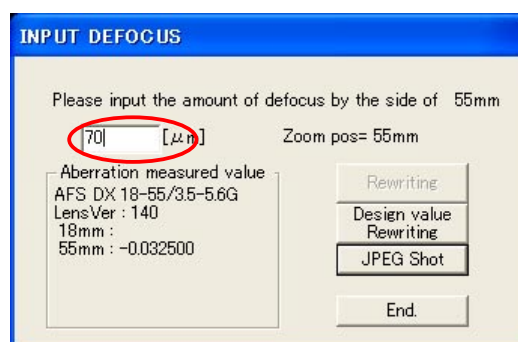

⑫ Set the focal length of the lens to 18 mm, and the distance between the test chart and camera (CCD face) to 72 ± 2 cm.

⑬ Perform the operations from ⑨ to ⑪ of the previous page.

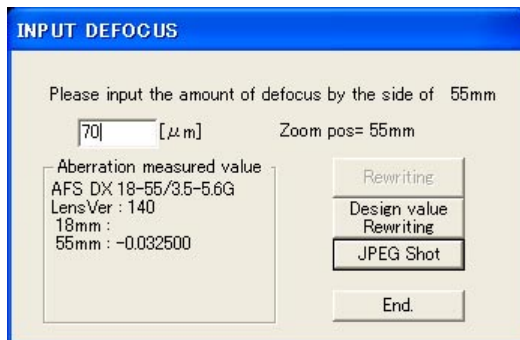

⑭ Check that the values of all the focal lengths are displayed within the dotted red circle. Then click on "Rewriting".

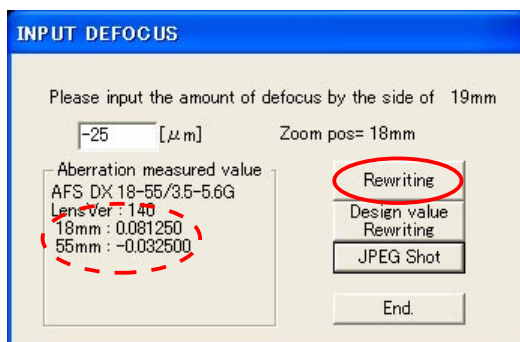

⑮ When "A compensation value is written in." is displayed, click "OK".

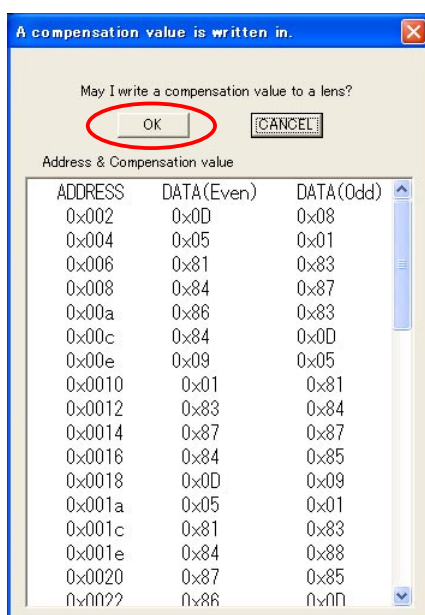

- ⑩ The reconfirmation screen is displayed. Click "OK".

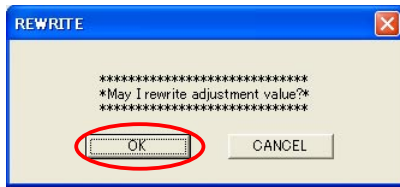

- ⑪ An hourglass is displayed on the screen, and writing starts.

The below screen is displayed after a few seconds. Turn camera OFF and turn it ON again.

Click "OK", and the adjustment software restarts.

Note: Unless the camera is turned off once, the value that was written in EEPROM is not reflected.

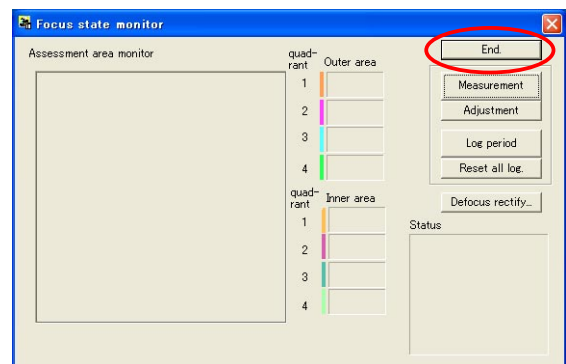
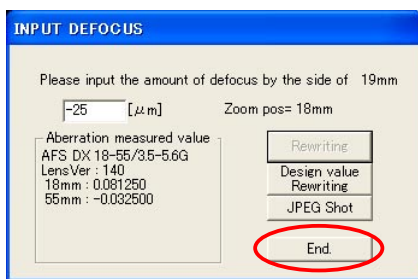
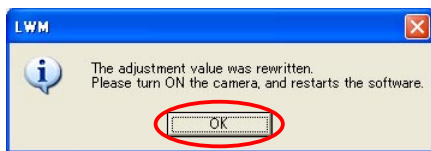

- ⑫ When the adjustment software restarts, perform the operations from ② to ⑬ again. Check that "0μm" of the AF position is in focus.

(It is also possible, after Wide-side shooting of ⑫, to take the Tele-side shooting of ②.)

If "0μm" is not in focus, repeat the operations from ② to ⑫.

If it is not still in focus even after repetition, the written value in EEPROM may be abnormal. So click "Design value Rewriting" to write the initial value, then proceed with the operations.

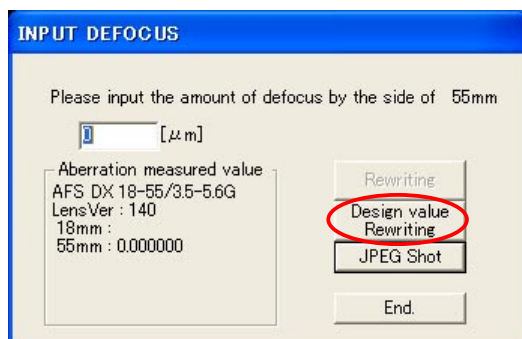

Lens alignment

Be sure to make an inspection and adjustment, when disassembling and repairing the lens-barrel.

1. Check the resolution

By shooting the high-definition resolution chart (J63079), confirm that the TV lines are within the standard.

Standard for the TV lines:

**1400 or more TV lines in the center ; 1200 or more TV lines on the periphery /4 corners
at both WIDE (18mm) and TELE (55mm)**

(ref. The unit of resolution is based on TV lines, which are total number of black-and-white strips distinguishable on the TV screen.)

Device: D100 camera, ITE high resolution chart (J63079), flicker-less fluorescent (AAA)

(a) Camera settings: Shooting-mode: Aperture-Priority Auto (A), Aperture: Full, Image quality mode (FINE), Image size (FULL), ISO (200), Image sharpening (None)

Reset other settings (e.g. compensation) and shoot pictures.

(b) To avoid light irregularity on the chart, for either 2 units of Z light (Z-309)(J19124) or 2 units of 15W inverter-type fluorescent stand, use fluorescent lamp color-rendering AAA (J19124A). Set them so that reflected light does not directly come in shot images. (ref. Pic.1)

As for exposure, open the shot images via PHOTOSHOP, and make an exposure compensation so that the value of RGV becomes 219 ± 10 LSB, when the cursor comes to white parts of the images.

(ref. : Set the exposure compensation to about +1-step for becoming 219 ± 10 LSB.)

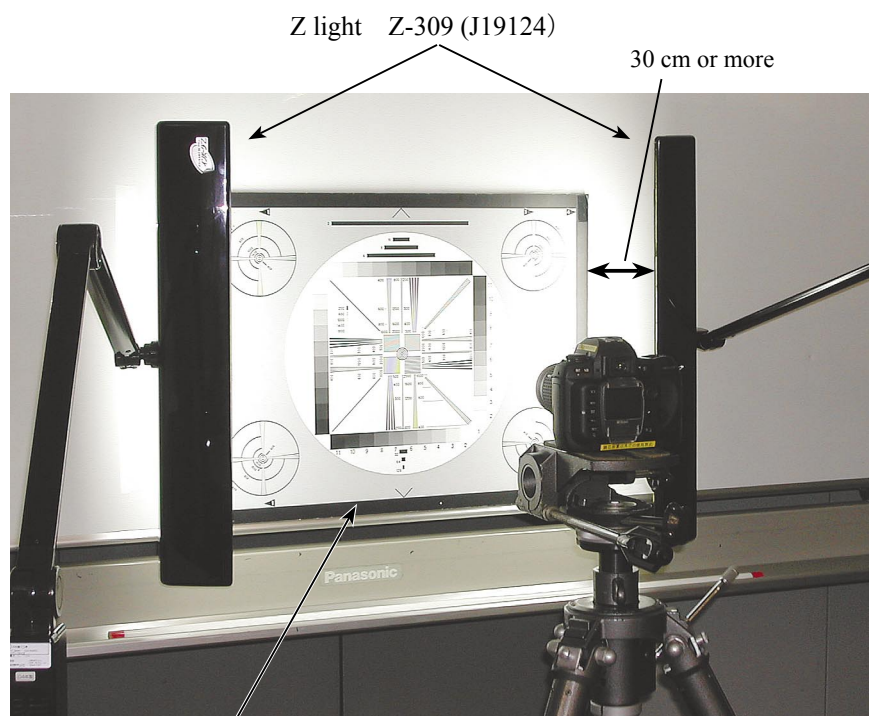

high-definition resolution
chart (J63079)

Pic.1

- (c) Check the zoom position at WIDE and TELE.

The object distance: WIDE (approx.0.6m), and TELE (approx.1.5m). Set the chart fully screened in the LCD of the camera and fix it on a tripod.

Because horizontal-to-vertical/aspect ratio is different between the chart and the finder field frame, align with the vertical direction (ref. Pic.1)

- (d) Open the shot image by Photoshop, and confirm it by the magnified display, e.g. 100%, etc.

- (e) Check if the resolution in the center and the 4 corners is identifiable in black and white at the position circled in red as below.

(Refer to the next page for sample of defective image.)

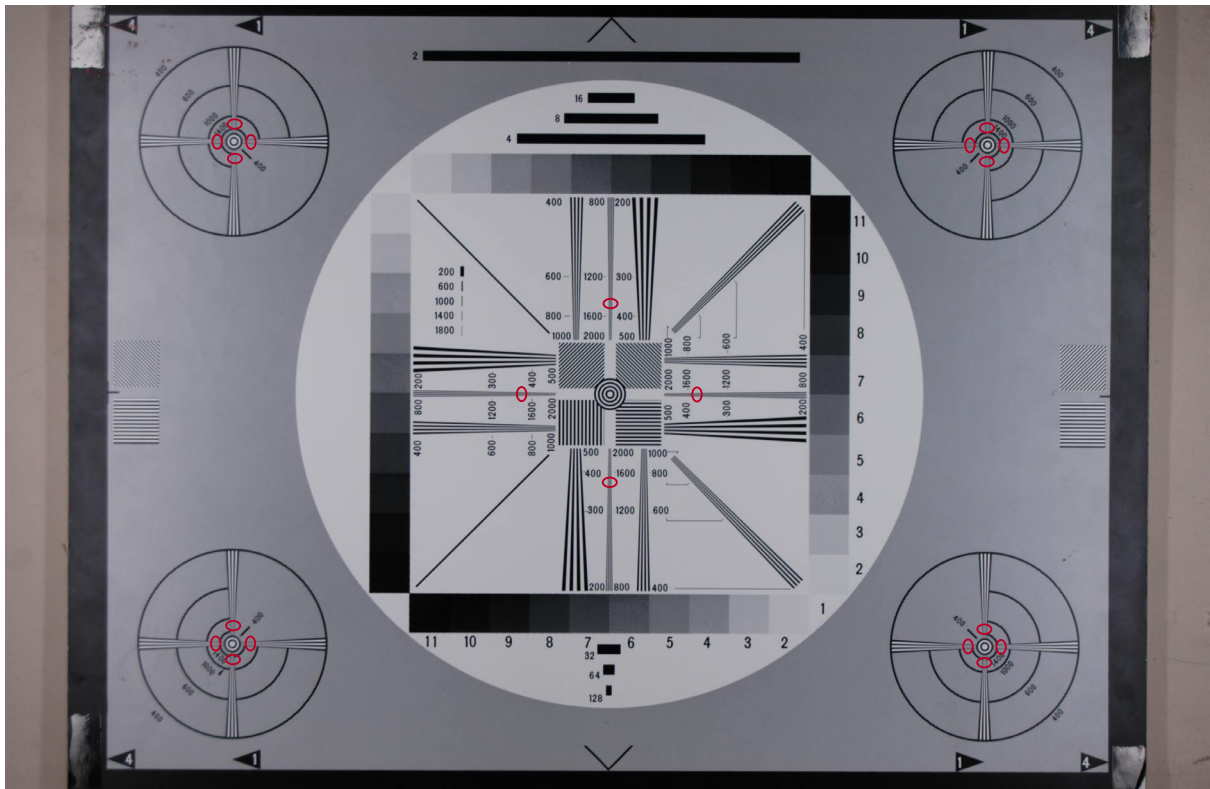

Pic.1

2. Sample image: for judging the chart (on the periphery)

Shoot pictures of the chart. In case TV lines of the center become less than 1400, or any of the periphery/4 corners shows the following image of defective samples (less than 1200 TV lines), make an adjustment on the next page.

Note: For the judgment, the defective image sample should be prioritized over the number of TVlines.



Defective at WIDE side



NON-defective at WIDE side



Defective at TELE side

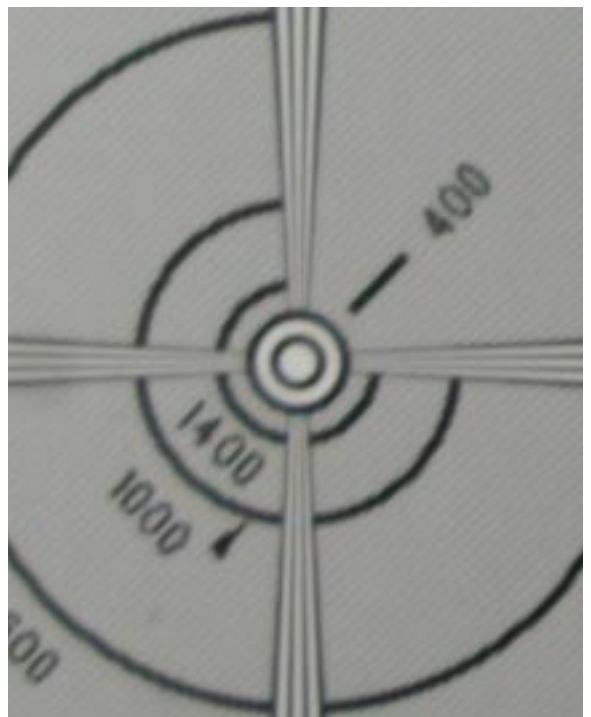

NON-defective at TELE side

3. Adjustment

In case the result of the resolution inspection becomes out of standard, detach the 1st lens group. Then, turn the 1st lens group through 90° to assemble into the body by using the 1st lens group assembling tool (J11315).

To find the best adjusted point, check the following: $90^\circ \rightarrow 180^\circ \rightarrow 270^\circ$. If all of these 3 points does not become within standard, some defective parts caused by a damage such as shock should be considered. Therefore, replace probable faulty parts (e.g. bayonet mount, 1st/2nd lens group, filter ring, fixed tube unit, etc) and make an inspection on resolution again.



Rubber ring

- Assemble the rubber ring (#62).



Rear cover ring

- Set the zoom to TELE side. Assemble the rear cover ring (#39) into the bayonet mount unit (#B27) and fix them with 3 screws (#91).



Name plate



Company name ring

- When the focus ring is set to the infinity-end, attach the company name ring (#113) so that the index position is aligned with "k" letter of "Nikon" of the ring.



Country of origin seal



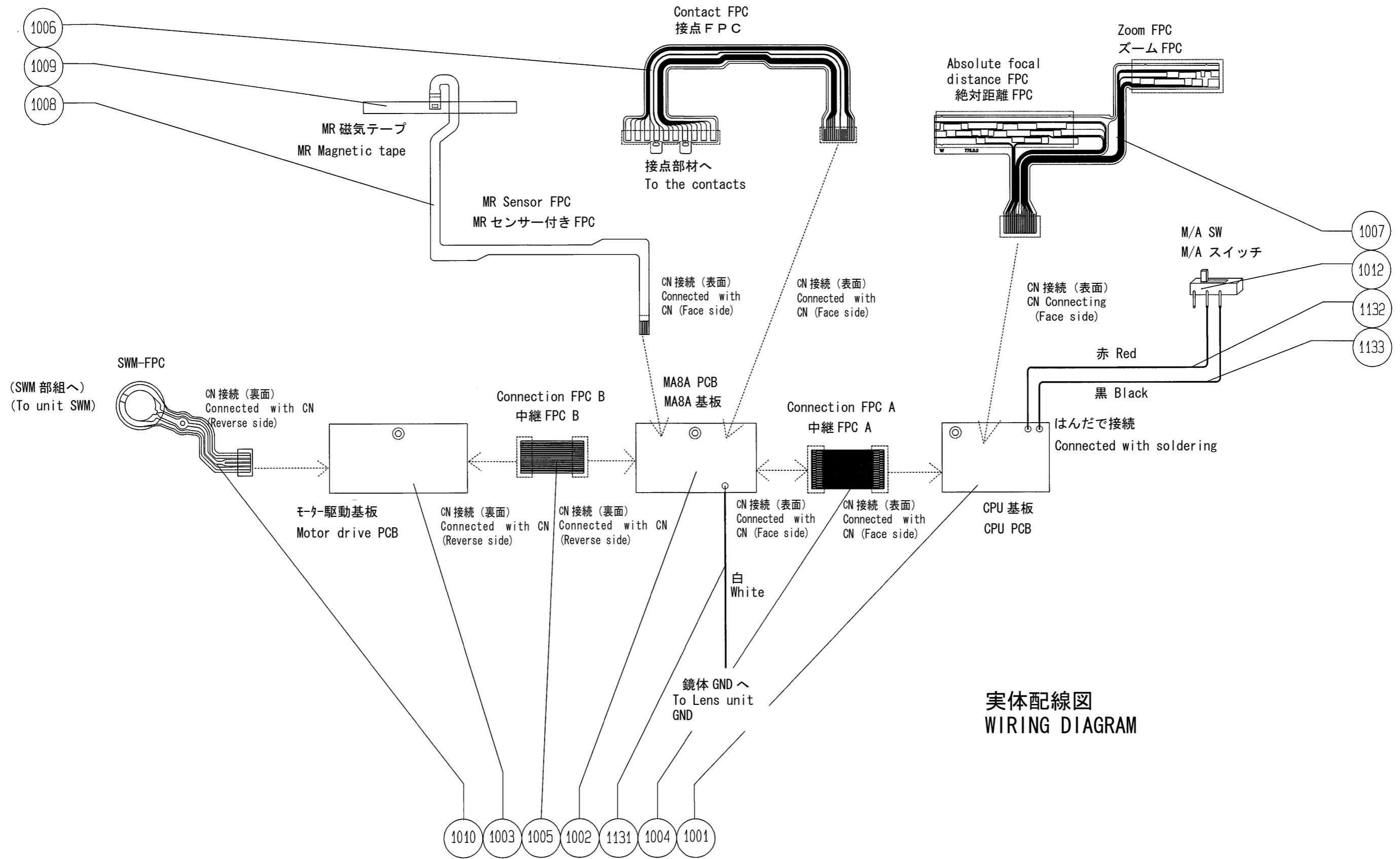

実体配線図
WIRING DIAGRAM

外觀図 Sketch drawings

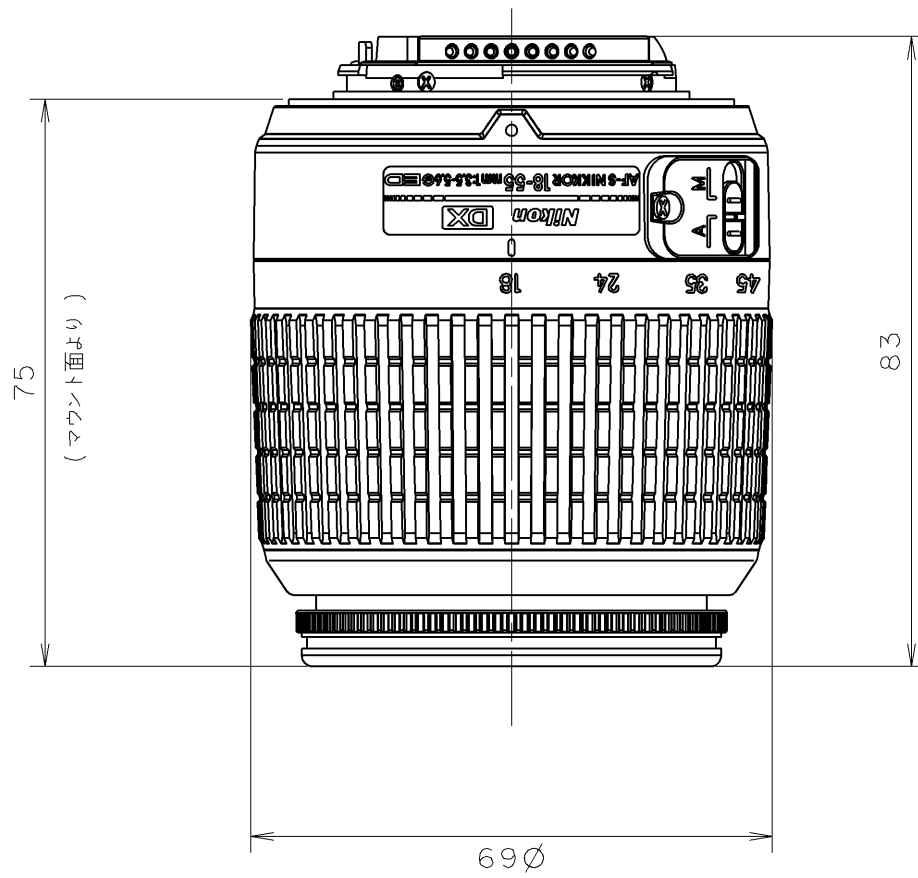

組立図 Structure of the Lens

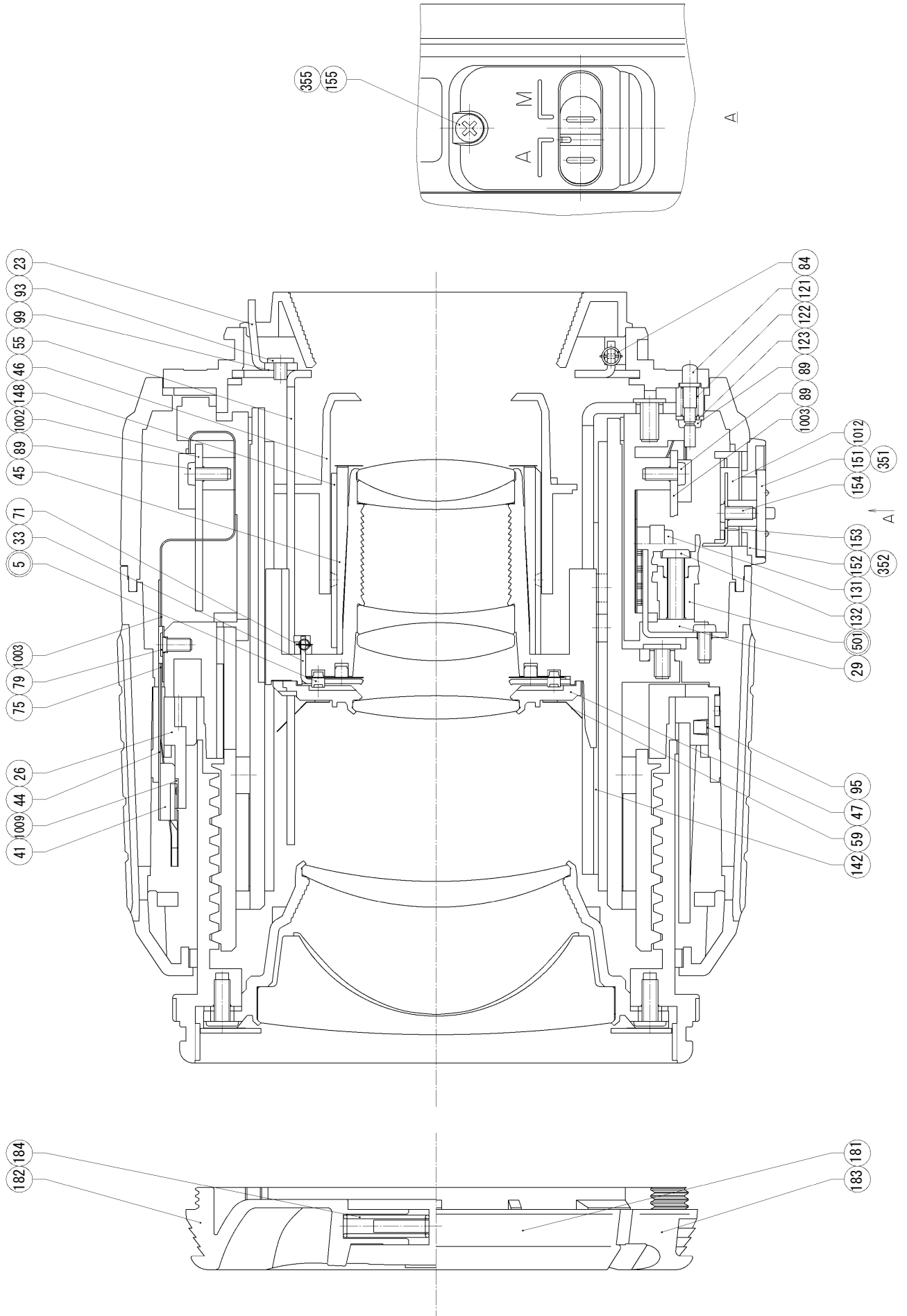

工具編 TOOLS

★ : NEW TOOL

RJ 番号 RJ No.	名称 NAME OF TOOL	備考 OTHERS
J19002 	縦型焦点面検査器 LT-500S BACK FOCUS COLLIMATER LT-500S	
J9001-5N	安定化電源 5 A DC REGULATED POWER SUPPLY 5A	
J18028 	F 用レンズ受け台 LENS ADAPTER FOR FOCUS TESTER	
★ J18387 	AF-S DX 18-55 点検・調整ソフト ADJ.FD FOR AF-S 300VR (IBM 3.5)	
J18004-1 	J 1 8 0 0 4 用基準ゲージ STANDARD GAUGE FOR J18004	
J15306-1 	A F - I 通信ボックス AF-I LENS COMMUNICATION BOX(CE)	
J15307 	A F - I 通信アダプター COMMUNICATION ADAPTER FOR AF-I	
自作工具 	自作工具 SELF-MADE TOOL	FOR AF-S24-85
★ J11315 	1 群組立工具 1ST LENS G ASSEMBLING TOOL	
★ J11316 	Z ブラシ挿入用シート Z BRUSH INSERTION SHEET	
J18379 	調芯装置用調整ソフト (LWM) ADJ.FD (LWM)FOR LENS ALIGNMENT	

★ : NEW TOOL

RJ 番号 RJ No.	名称 NAME OF TOOL	備考 OTHERS
J19124A 	蛍光ランプ FL15N-EDL(15W) FLUORESCENT LAMP FL15N-EDL(15W)	
J19124 	Z ライト Z-309 Z-LIGHT Z-309	
J63079 	ITE 高精細解像度チャート (4:3 反射型) ITE HIGH RESOLUTION CHART (4:3 REFLECT TYPE)	
工具設定なし RJNo. is not available 	鉛フリーはんだコテ LEAD FREE SOLDERING IRON	
J5400 	鉛フリー糸はんだ RMA02(M705) 0.5MMX500G ECO SOLDER RMA02(M705) 0.5MMX500G	
工具設定なし RJNo. is not available	パーソナルコンピュータ PERSONAL COMPUTER	
工具設定なし RJNo. is not available	オシロスコープ OSCILLOSCOP	
OS-30MF	ドライサーフ OS-30MF DRY SERF OS-30MF(OIL BARRIER)	
I-40	A F レンズ用グリース (I-40) GREASE FOR AF LENS	
EDB0011	ネジ ロック (赤) 1401C SCREW LOCK 1401C	
工具設定なし RJNo. is not available	アロンアルファ QUICK DRY GLUE	汎用品
C-8008B	セメダイン (黒) CEMEDAIN 8008(BLACK)	
G92KA	フロイル G92KA FLOIL G92KA	
MZ-800S	ドライサーフ MZ-800S DRY SURF MZ-800S	

Making of self-made tool

- It is necessary to make a self-made tool by using the RP main PCB of AF-S 24-85/3.5-4.5G. The self-made tool will be used for "INSPECTION AND ADJUSTMENT FOR THE WAVEFORM OUTPUT FROM MR ENCODER".

The making procedure is shown below. Make a self-made tool according to this procedure.

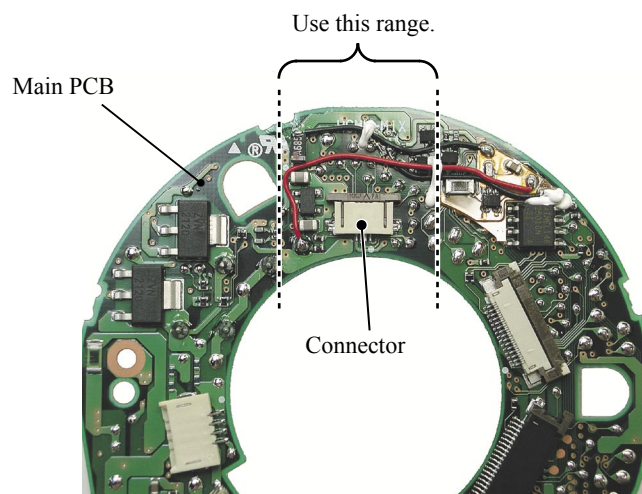

- ① Remove the elements (condenser, transistor, IC, etc.) installed within the dotted line as shown in the left from both sides of PCB. Don't remove the connector.
- ② Cut the PCB at the dotted line.

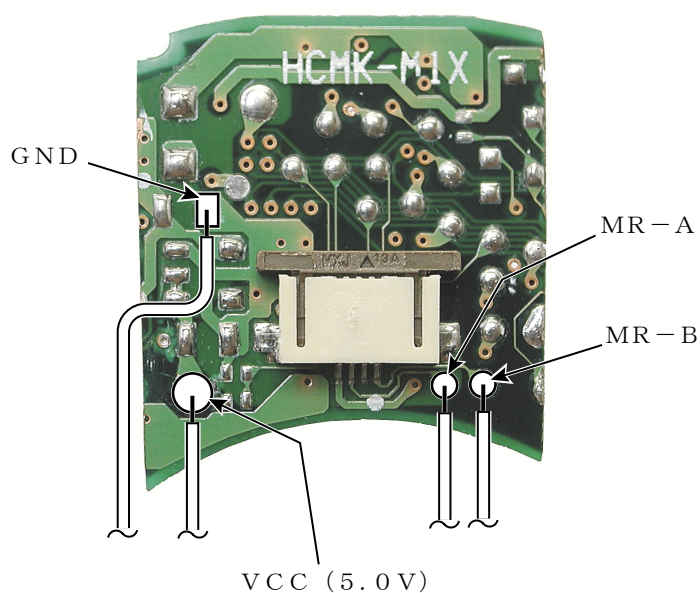

- ③ Solder the cords at 4 pattern places on the PCB as shown in the left.