

作成承認印

配布許可印



AF-S DX Zoom-Nikkor
ED 17-55mm f/2.8G IF

JAA78851

REPAIR MANUAL

Nikon | NIKON CORPORATION
Tokyo, Japan

Copyright © 2004 by Nikon Corporation.
All Rights Reserved.

SPECIFICATIONS

This lens can be used for Nikon digital SLR camera only.

Type of lens	G-type AF Zoom- Nikkor lens having built-in CPU and Nikon F bayonet mount
Focal length	17mm - 55mm (22.5 - 82.5 mm in 35 mm format)
Maximum aperture	f/2.8
Lens construction	14 elements in 10 groups (3 aspherical lens and 3 ED lens elements)
Picture angle	79° - 28° 50' (with Nikon Digital Camera D1/D1H/D1X/D100)
Focal length scale	17,20,24,28,35,45,55mm
Distance information	Output to camera body
Zoom control	Manually via separate zoom ring
Focusing	Nikon Internal Focusing (IF) system (utilizing an internal Silent Wave Motor); manually via separate focus ring
Shooting distance scale	Graduated in meters and feet from 0.36m (1.25ft.) to infinity (∞)
Closest focus distance	0.36m (1.2ft.) at all zoom settings
Diaphragm	Fully automatic
Aperture range	f/2.8-f/22 at all zoom settings
Exposure measurement	Via full-aperture method with cameras having CPU interface system
Attachment size	77mm (P=0.75mm)
Dimensions	Approx. 85.5mm dia. ×110.5mm extension from the camera's lens mount flange
Weight	Approx.755g

※ Before Disassembly / (Re)assembly / Adjustment

If the 1st lens group and 4th lens group of this lens are removed, lens alignment becomes necessary after assembling.

Therefore, at service agencies where the lens alignment cannot be performed, remove neither the 1st lens group nor 4th lens group.

DISASSEMBLY

FILTER RING

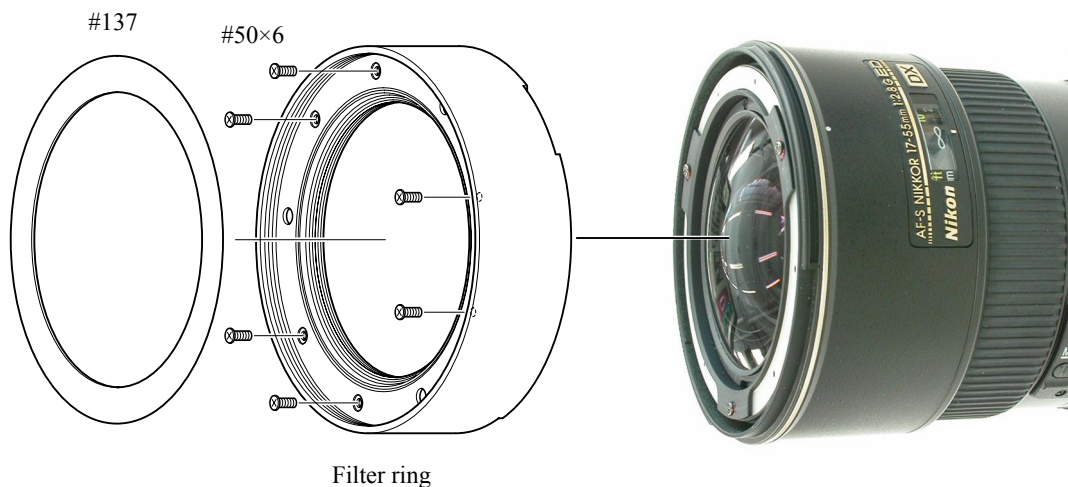

Filter ring

1ST LENS GROUP



1st lens group

Note: If the 1st lens group is removed, lens alignment of the 1st lens group becomes necessary. Therefore, at service facilities where the point tester is not prepared, do NOT disassemble.

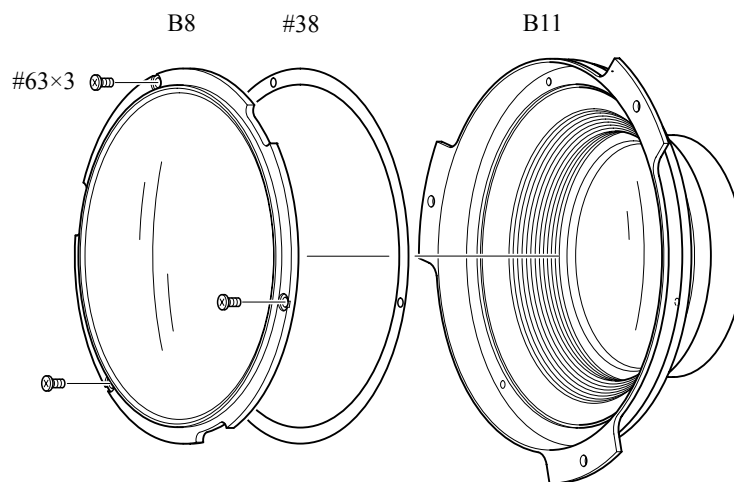

2ND LENS GROUP



Fig.1



Fig.2

- Set the focus ring to the close-end, and the zoom ring to slightly 35-mm side from 28 mm.
- Assemble J11303B into the cam ring to seat in notches of the cam ring, then insert the pin (J11303C) into the hole of J11303B. (ref. Fig.1)
- Remove the 2nd lens group with the wrench for 2G AF-S 17-35DX (J11303A). (ref. Fig.2)

REAR COVER RING

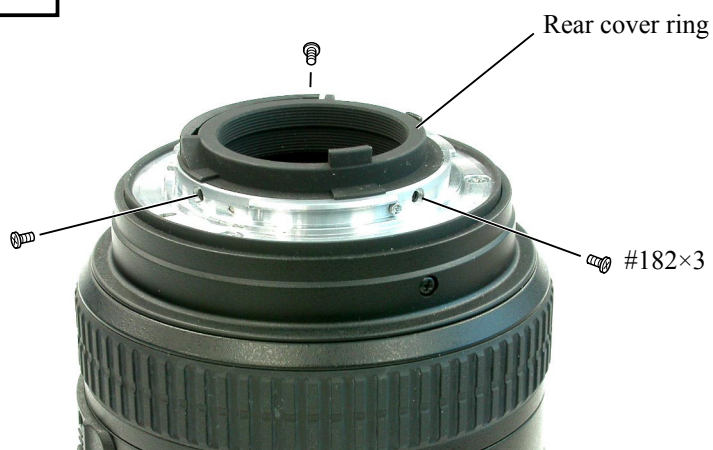

BAYONET MOUNT



4TH LENS GROUP

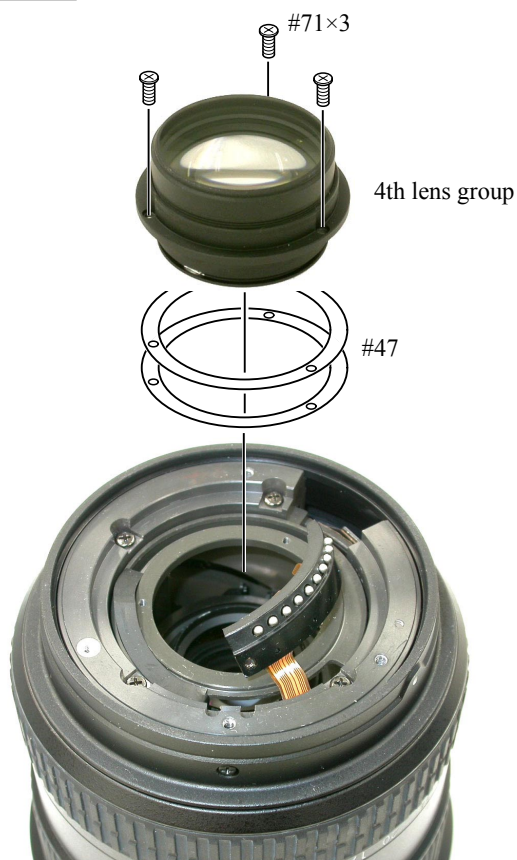

Note: If the 4th lens group is removed, the lens alignment becomes necessary. Therefore, at service facilities where the lens alignment equipment is not prepared, do not disassemble.

INDEX RING



ZOOM ENCODER BRUSH



Fig.1

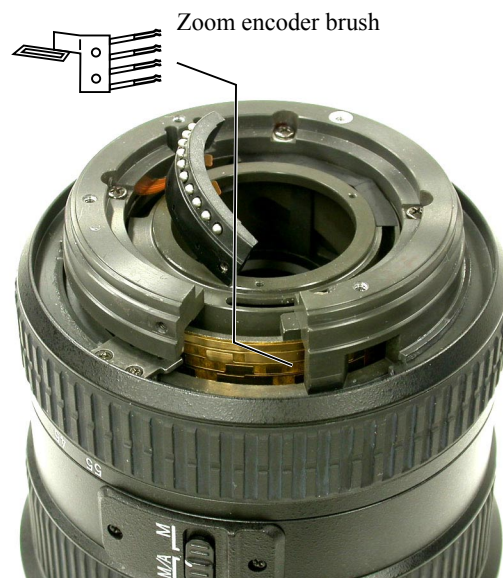
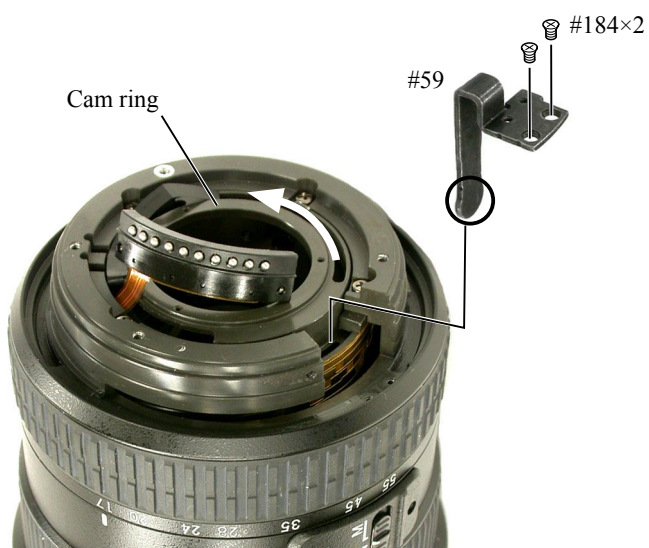

Fig.2

- Set the zoom ring to 17 mm, and take out 2 screws (#96). (ref. Fig.1)
- Set the zoom ring to 28 mm, and remove the zoom encoder brush. (ref. Fig.2)

ZOOM CONNECTING PLATE



- Set the zoom ring to WIDE-end.
- Take out 2 screws (#184) to remove the zoom connecting plate.

ZOOM RING

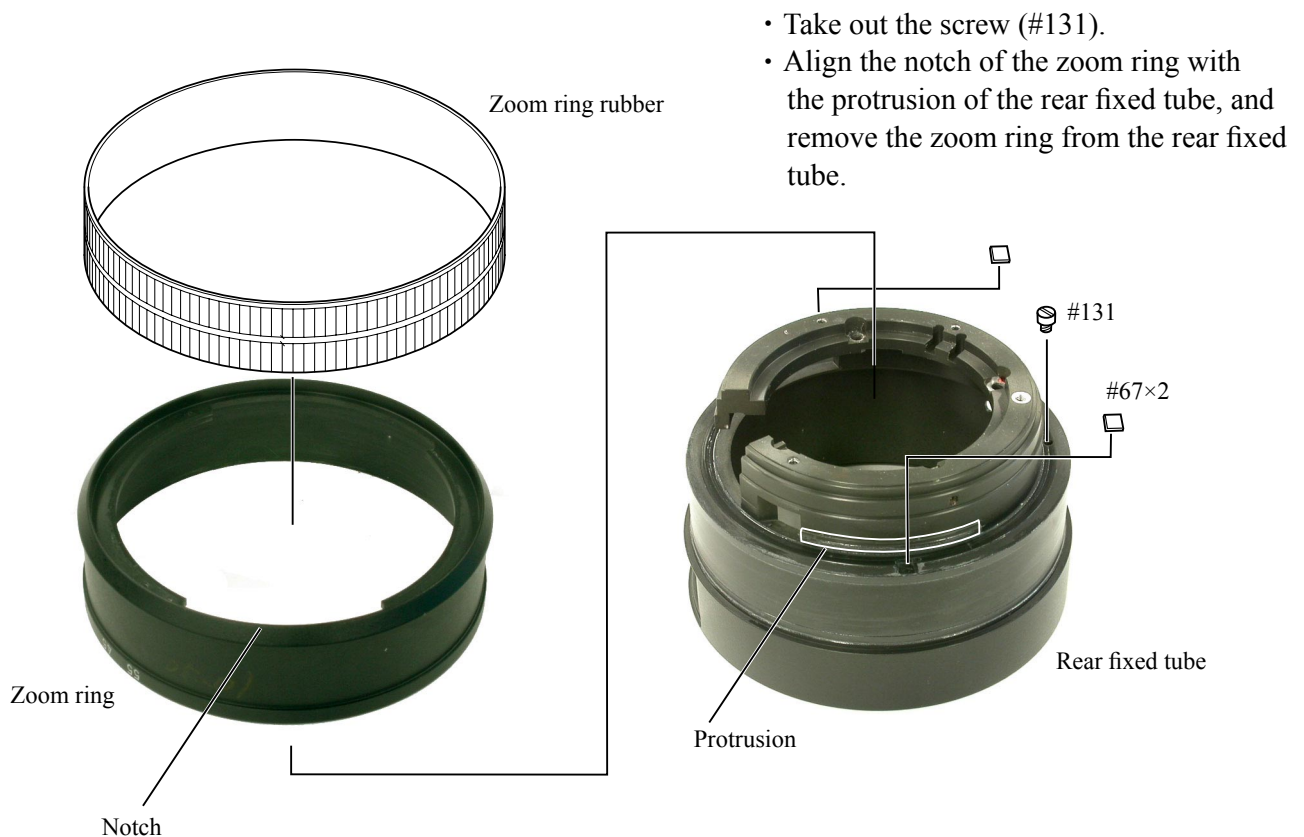

AF CONTACT UNIT

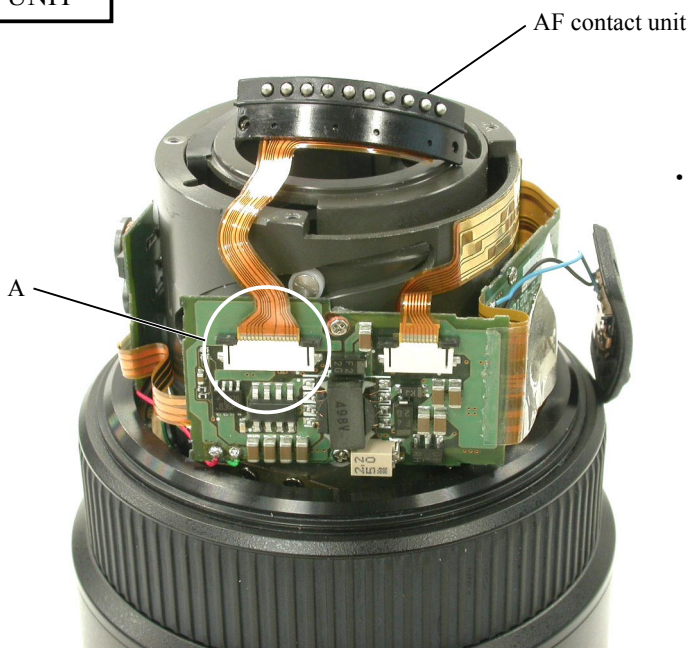

- Remove the AF contact unit from the connector A of the main PCB.

LIGHT-SHIELDING SHEET

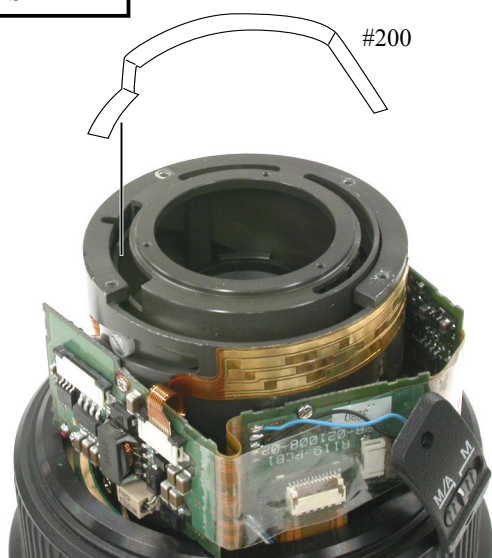

- Peel off the light-shielding sheet (#200).

M/A SELECTOR SWITCH



- Remove the tape of the main PCB.

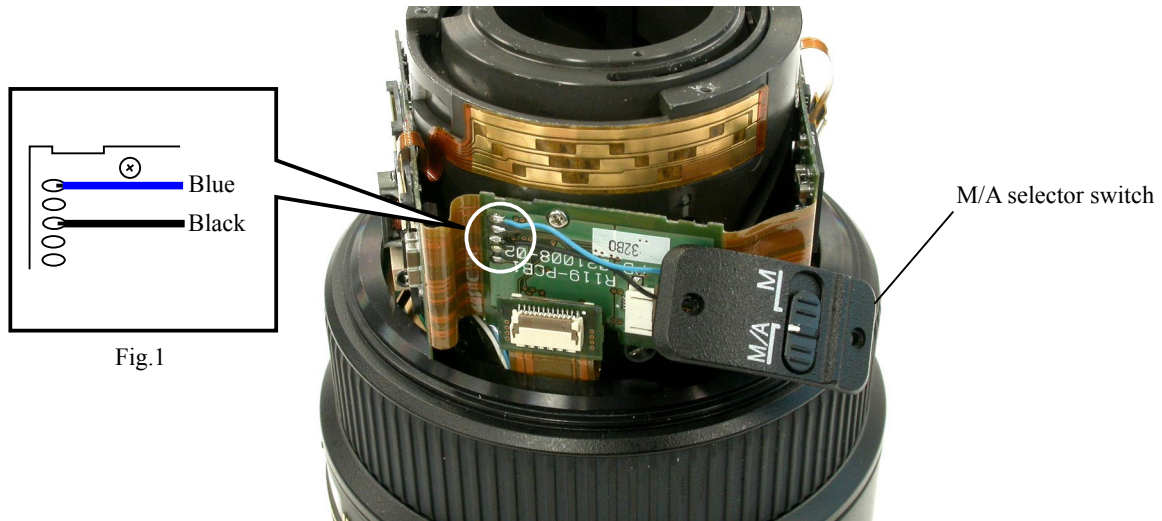

- Unsolder 2 parts, and remove the M/A selector switch. (ref. Fig.1)

MAIN PCB

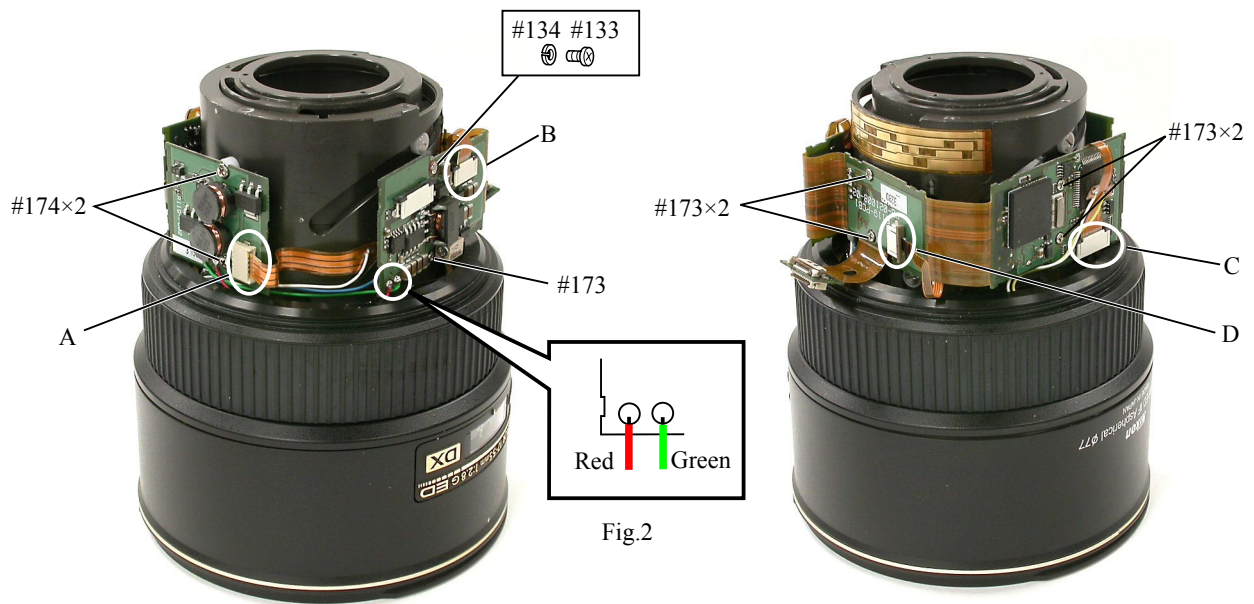

- Unsolder 2 parts. (ref. Fig.2)
- Remove 4 connectors (A-D).
- Take out the screw (#133) and 5 screws (#173) and 2 screws (#174) to remove the main PCB.

ZOOM ENCODER FPC



- Peel off the zoom encoder FPC.

FOCUS RING



M/A BRUSH

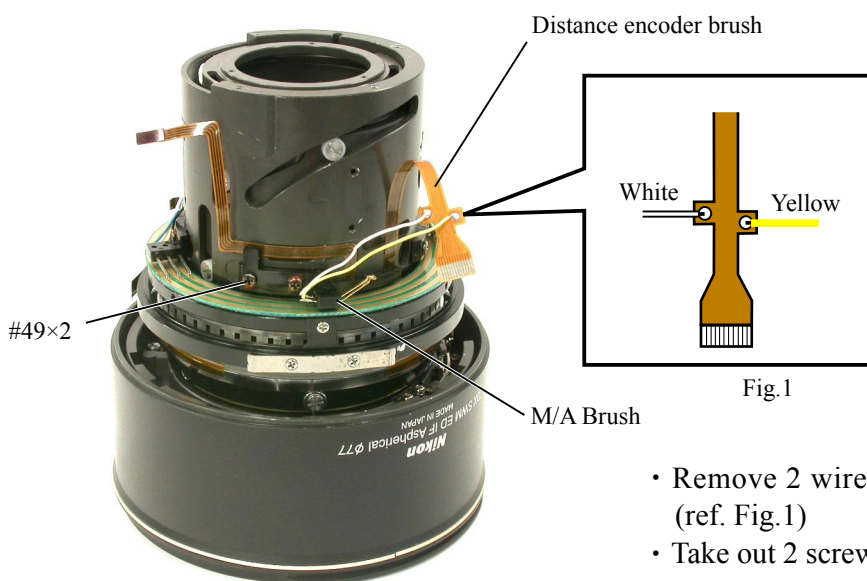

- Remove 2 wires of the distance encoder FPC. (ref. Fig.1)
- Take out 2 screws (#49) to remove M/A brush.

POWER BRUSH

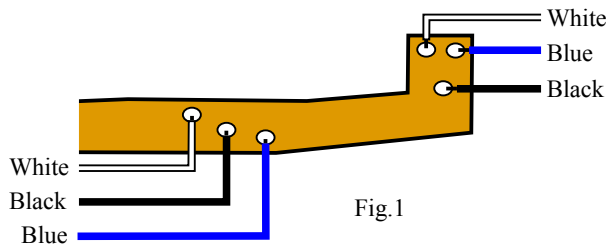
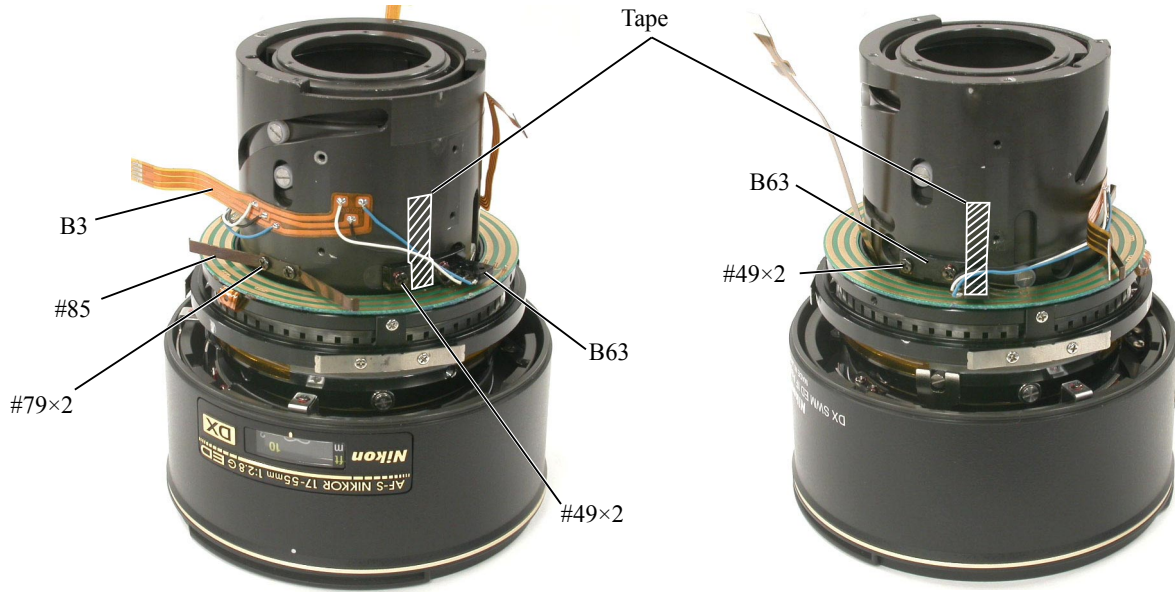

Fig.1

- Remove 2 pieces of tapes that fix the wire of the power brush.
- Unsolder 6 wires of the power brush. (ref. Fig.1)
- Take out 2 screws (#49) to remove the power brush B63 (at 2 parts).
- Peel off the FPC B3.
- Take out 2 screws to remove the spring (#85).

DISTANCE SCALE PLATE



- Take out 2 screws (#62) to remove the distance scale plate.

HOOD-FIX TUBE



- Take out 6 screws (#166) to remove the hood-fix tube.

1ST LENS GROUP STRAIGHT RING

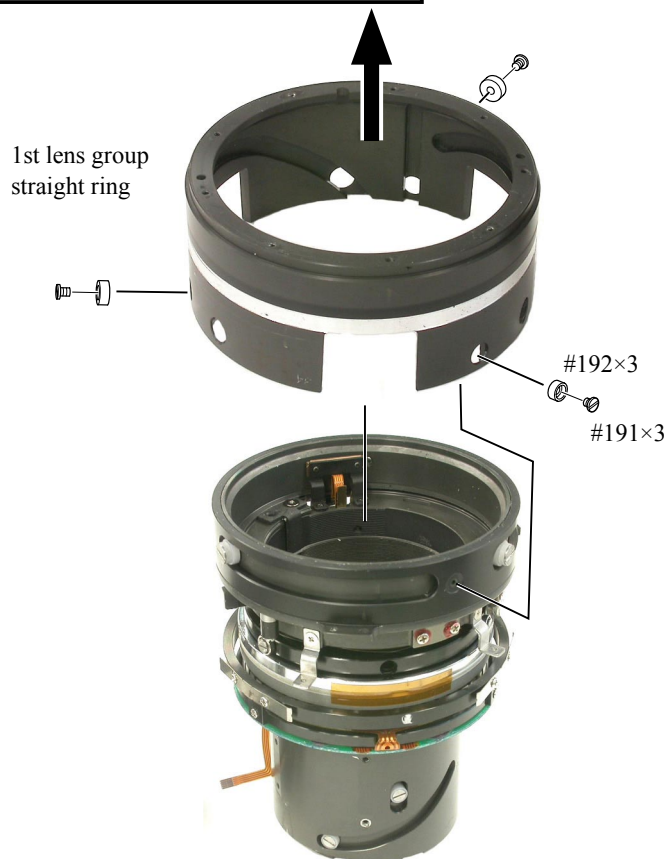

- Pull up the 1st lens group straight ring in the direction indicated by the arrow, then take out 3 screws (#191) and 3 rollers (#192) to remove the 1st lens group straight ring.

FOCUS SLIDING UNIT

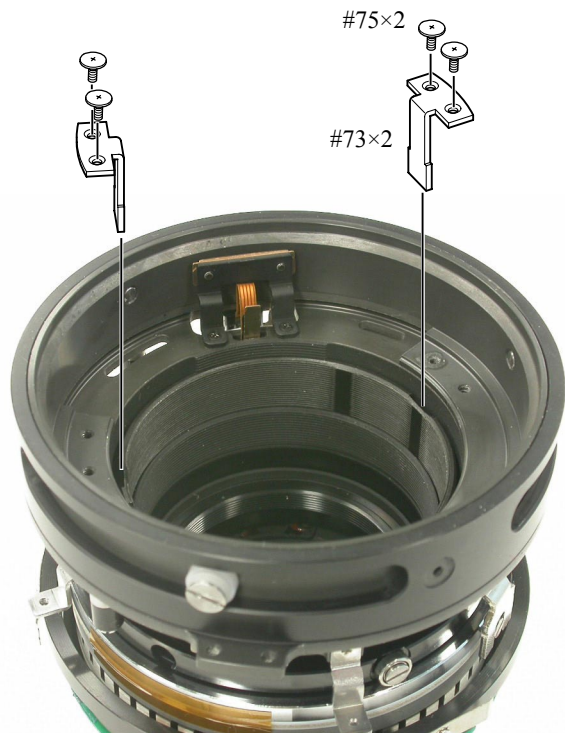

- Take out 2 screws (#75) to remove 2 levers (#73).



- Take out 3 screws (#80) to remove #48.
- Take out 2 screws (#130) to remove #164. (ref. Fig. 1)

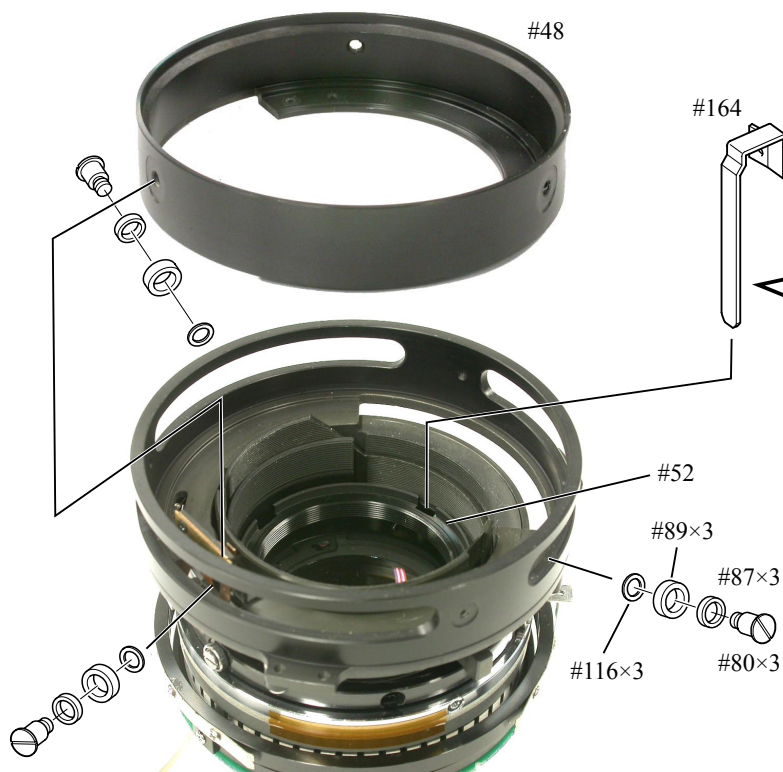
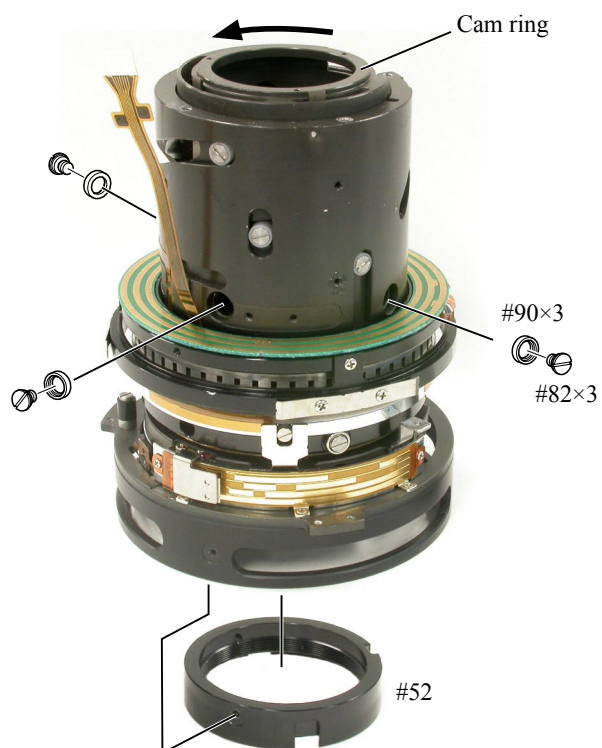
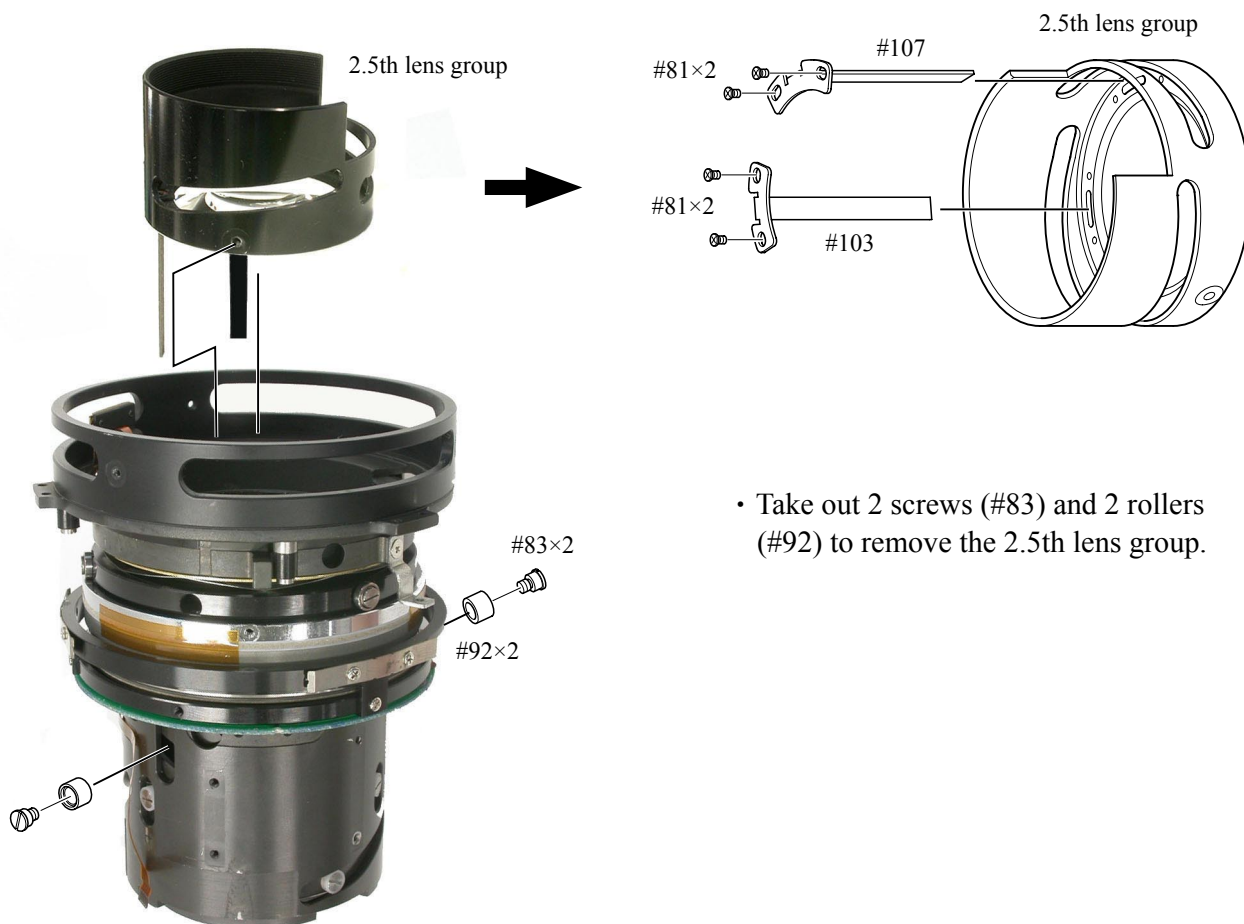

Fig.1



- Turn the cam ring almost all the way to the limit in the direction of the arrow so that the roller mounting hole of the cam ring can be seen.
- Take out 3 screws (#82) and 3 rollers (#90) to remove #52.

2.5TH LENS GROUP



- Take out 2 screws (#83) and 2 rollers (#92) to remove the 2.5th lens group.

APERTURE BLADE HOUSING UNIT

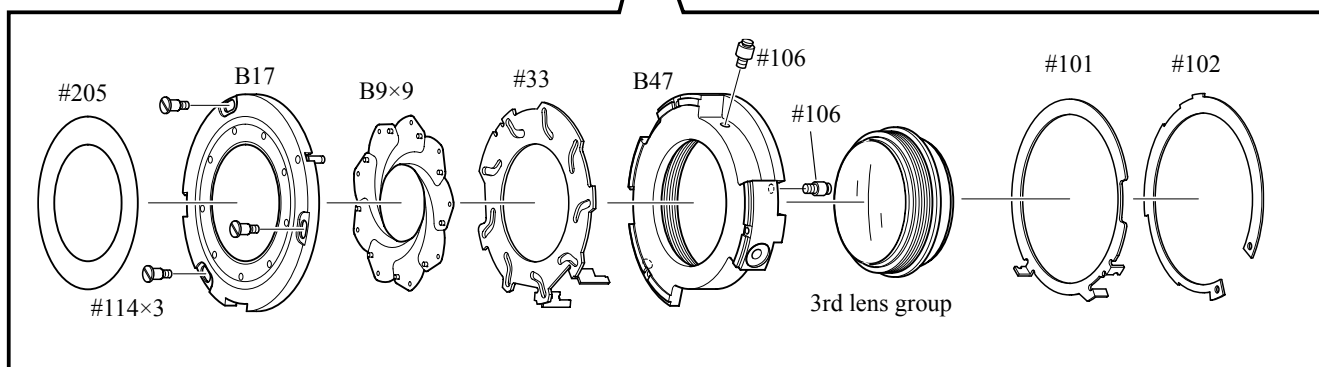
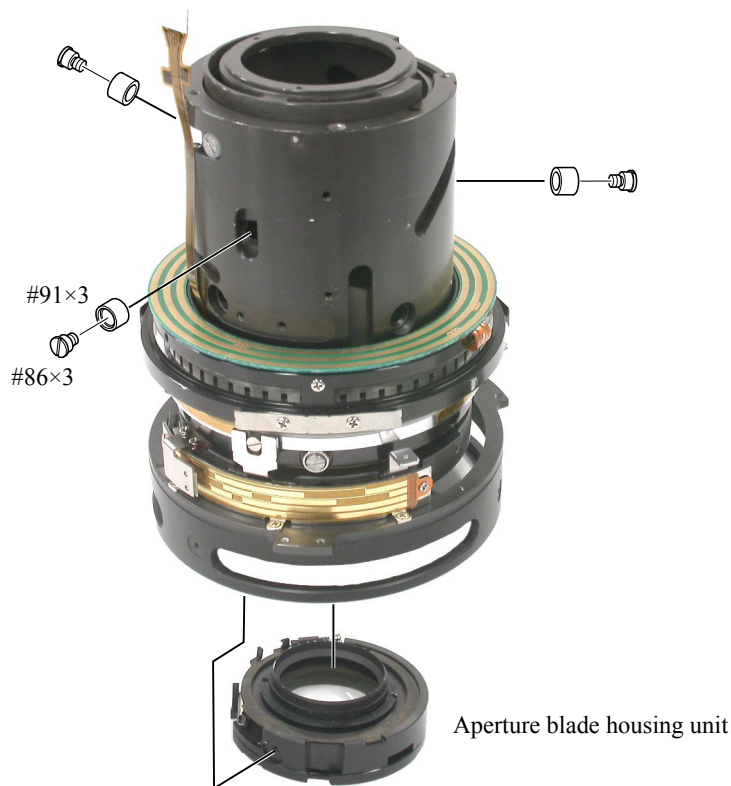

CAM RING GROUP

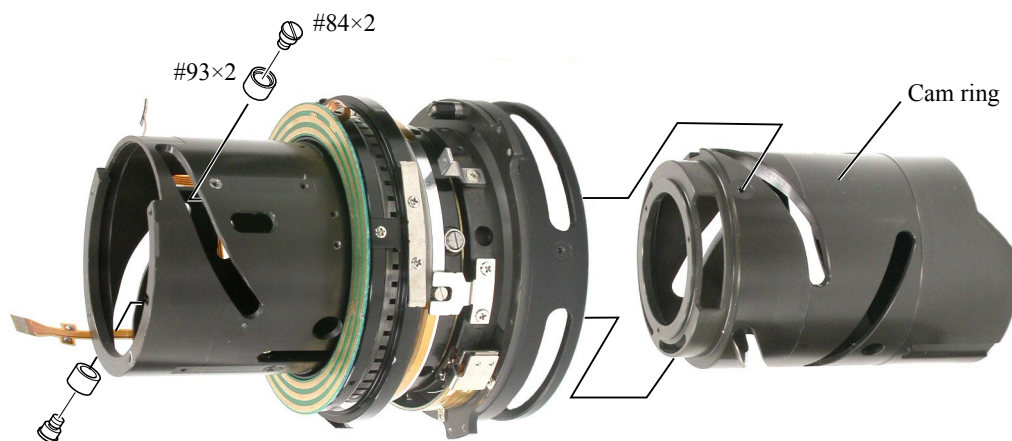

SWM UNIT

- Pass the FPC through the hole as shown in Fig.1, and put it into the lens body in position.

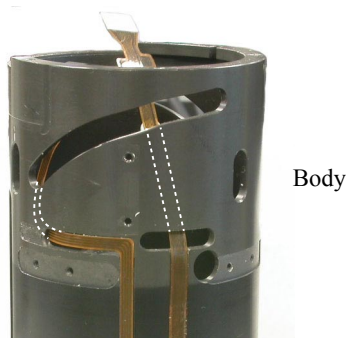

Fig.1

FPC

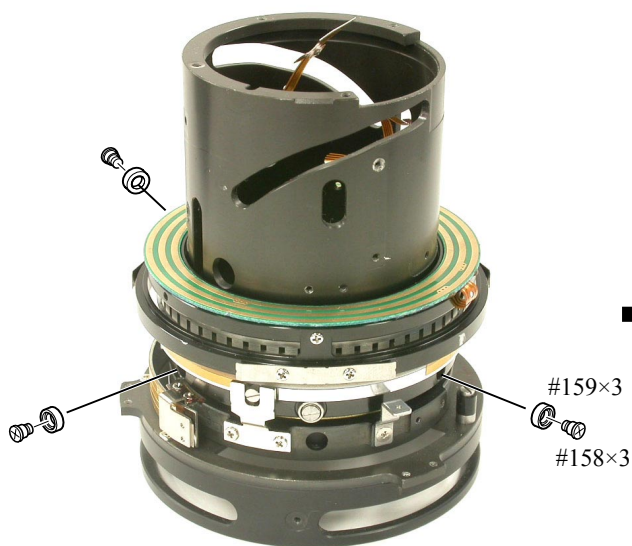

Fig.2

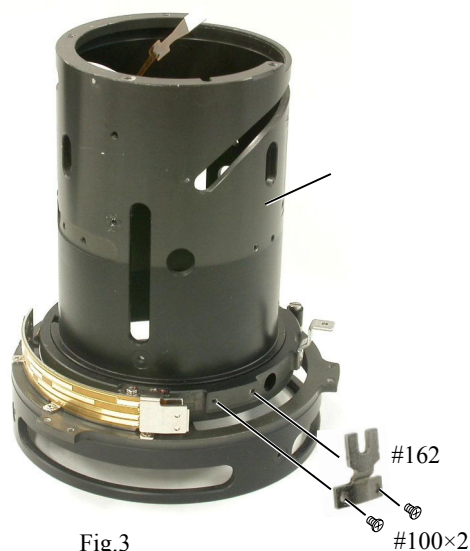
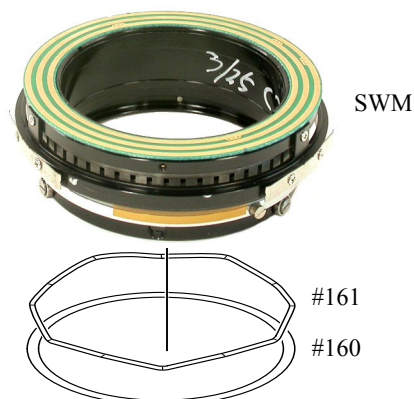
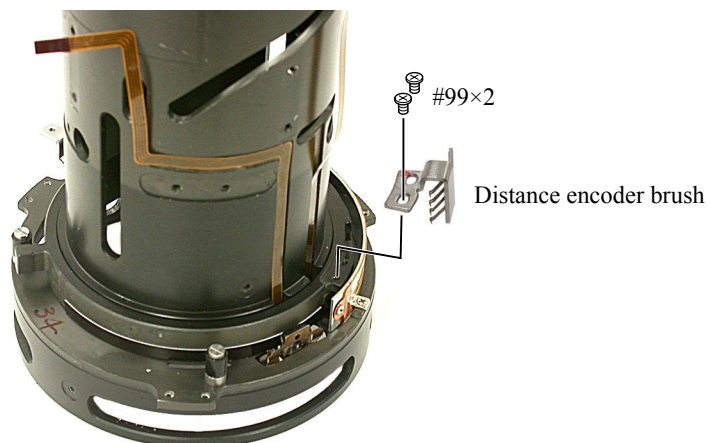

Fig.3

- Take out 3 screws (#158) and 3 rollers (#159). (ref. Fig.2)
- Remove the SWM, the washer (#160) and the wave washer (#161). (ref. Fig.3)
- Take out 2 screws (#100) to remove the SWM connecting key (#162). (ref. Fig.3)
- Take out the FPC which was put into the lens body.

DISTANCE ENCODER BRUSH



DISTANCE SCALE PLATE MOUNTING-BASE



MAGNETIC TAPE UNIT

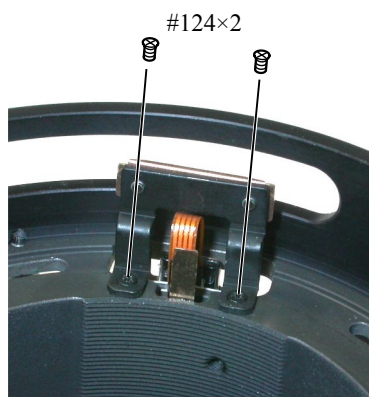
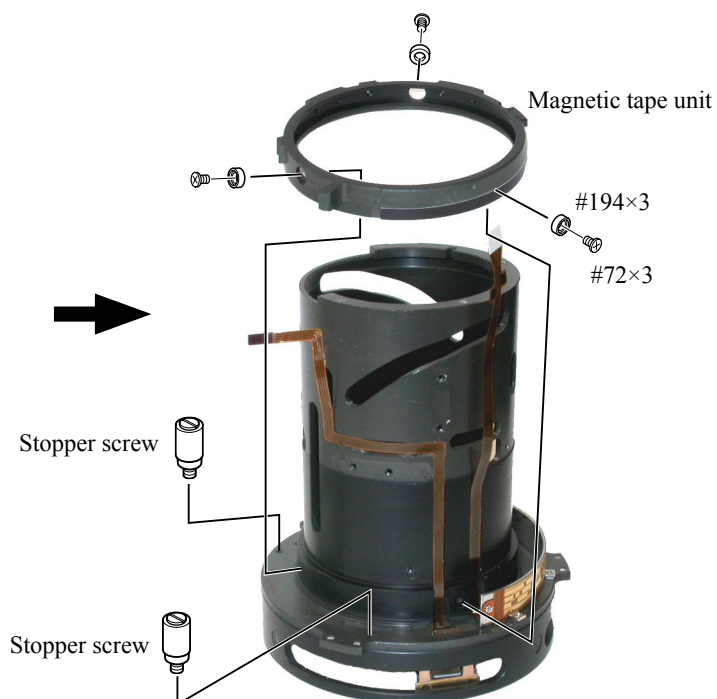
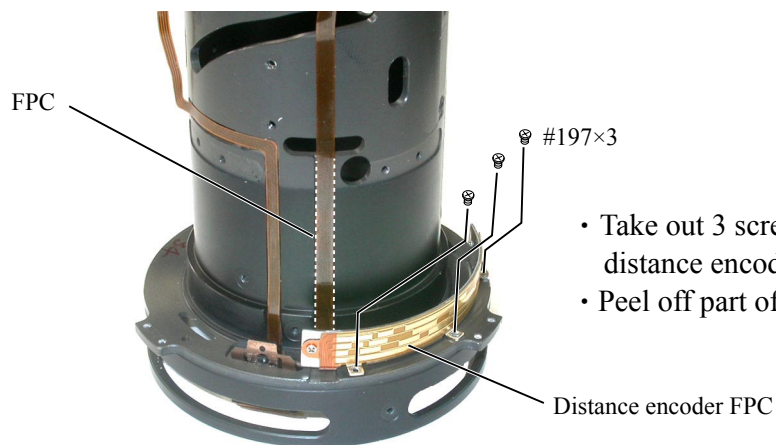

Fig.1



- Take out 2 MR head fixing screws (#124). (ref. Fig.1)
(to prevent damage on the magnetic tape unit)
- Take out 3 screws (#72) and 3 rollers (#194) to remove the magnetic tape unit.
- Take out the 2 stopper screws.

DISTANCE ENCODER FPC



- Take out 3 screws (#197) to remove the distance encoder FPC.
- Peel off part of the FPC shown by broken line.

MR HEAD

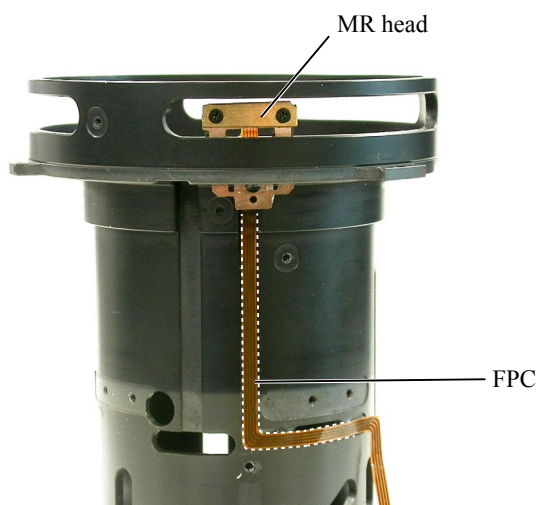

- Peel off part of the FPC shown by broken line. (ref. Fig.1)
- Remove the MR head. (ref. Fig.2)

Fig.1

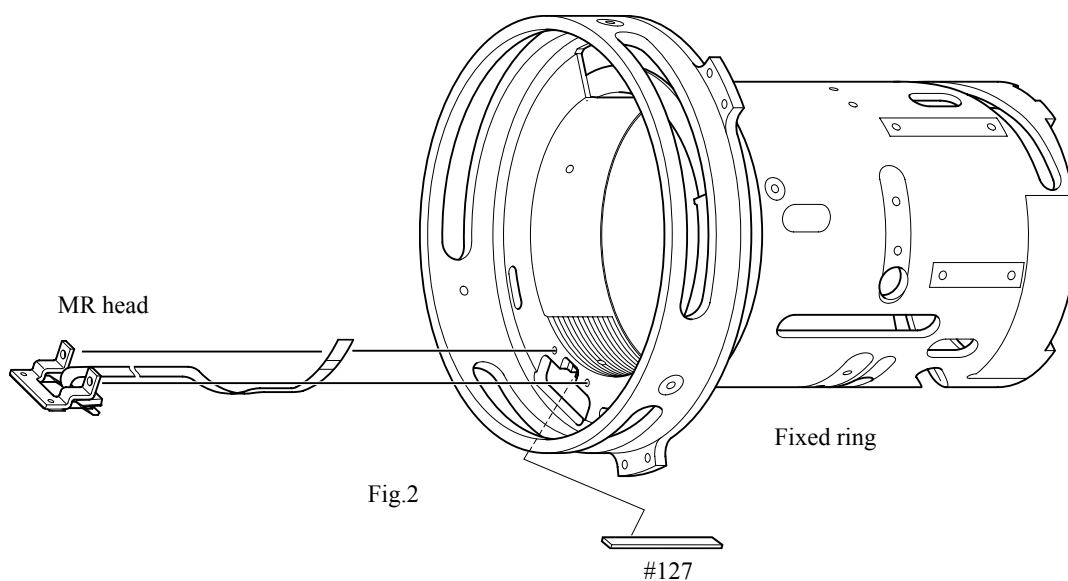
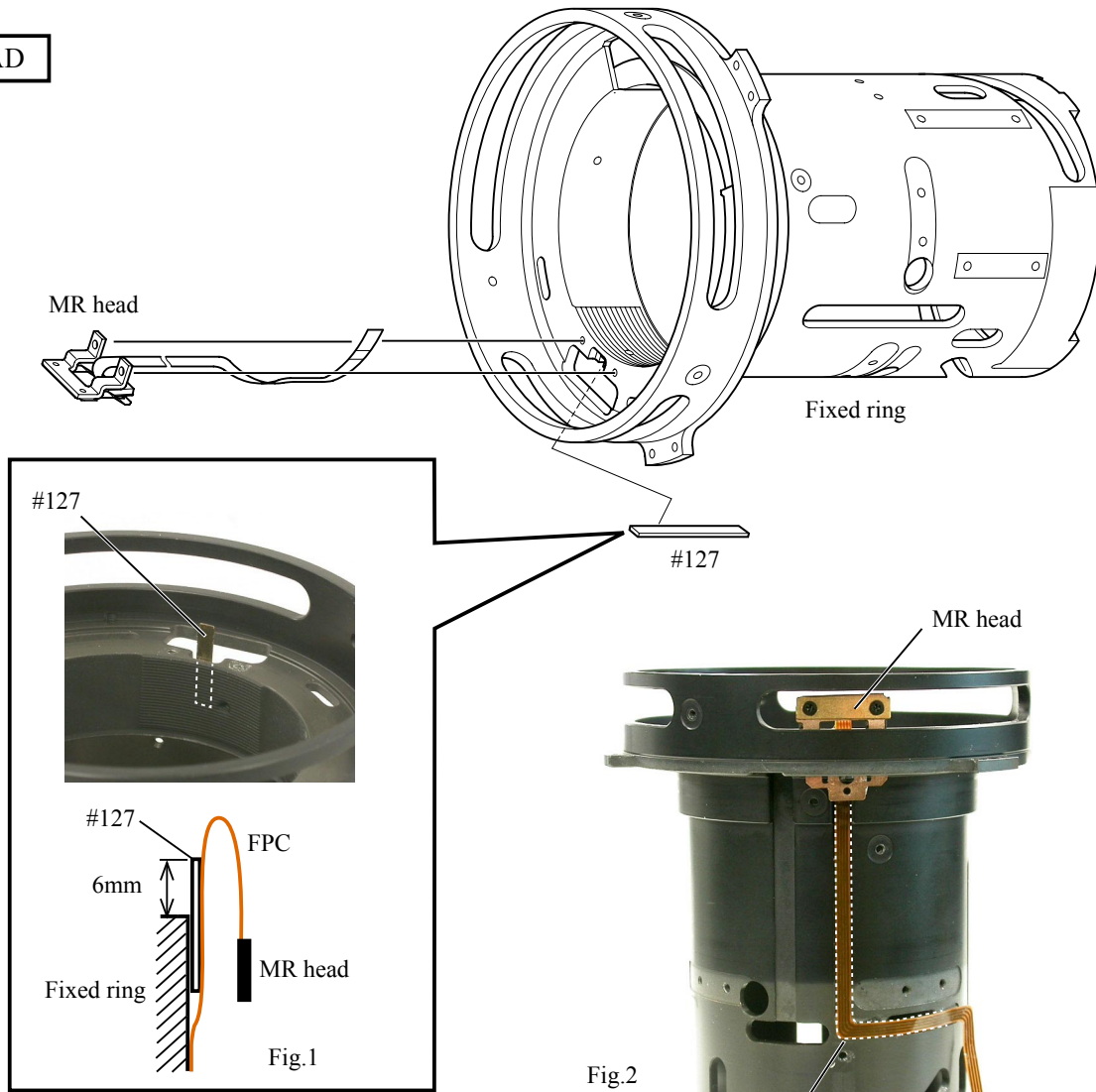

Fig.2

ASSEMBLY

MR HEAD



- Attach #127 on the fixed tube. (ref. Fig.1)
 - Attach MR head FPC. (ref. Fig.2)
- Do not screw the MR head at this stage.

Attach the FPC along the broken lines.

DISTANCE ENCODER FPC

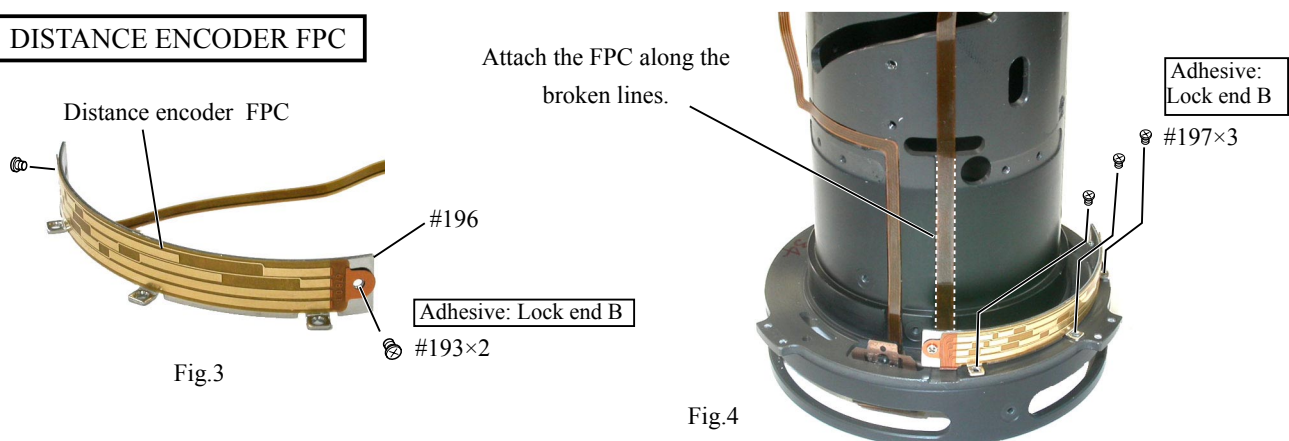

- Attach the distance encoder FPC on #196 by aligning it with the screw hole for #193, then tighten 2 screws (#193). (ref. Fig.3)
- Mount #196, on which the distance encoder FPC was attached, on the fixed tube, then tighten 3 screws (#197). (ref. Fig.4)

MAGNETIC TAPE UNIT

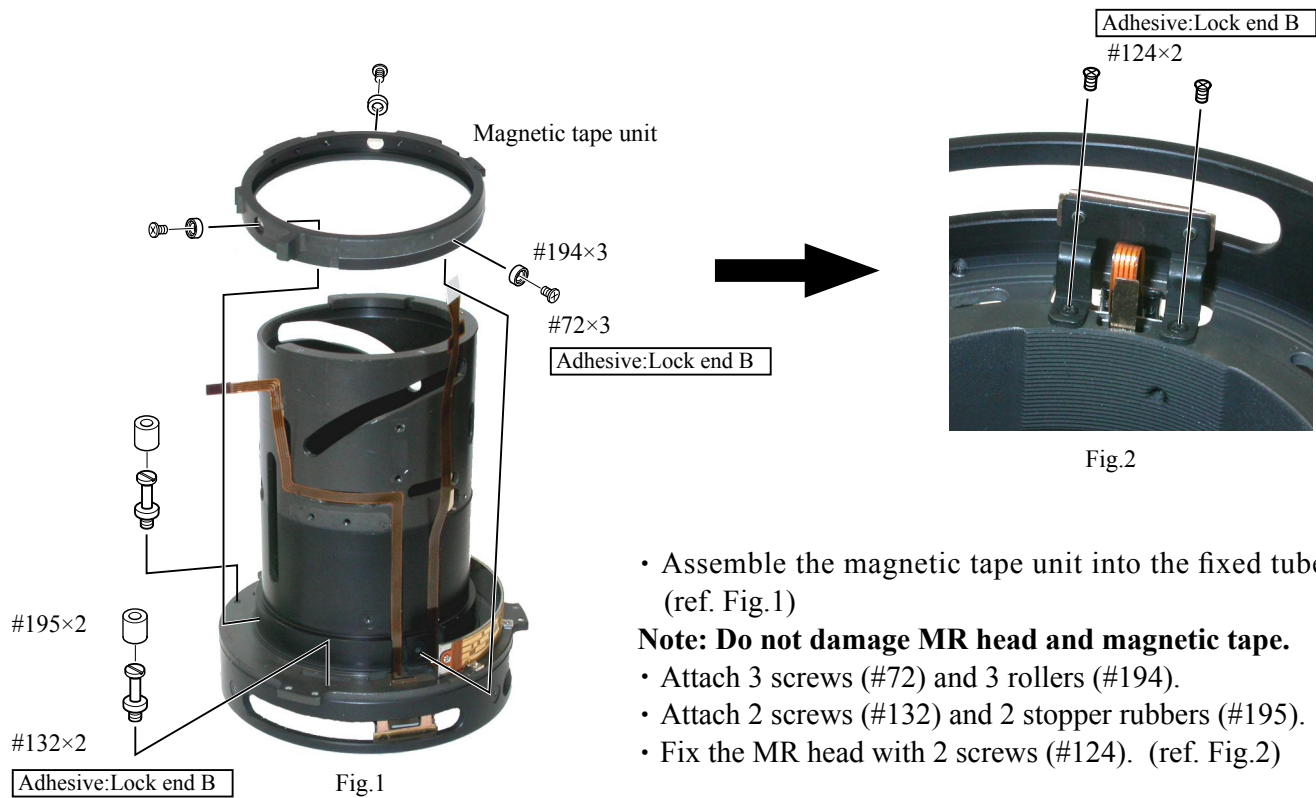

- Assemble the magnetic tape unit into the fixed tube. (ref. Fig.1)
- Note: Do not damage MR head and magnetic tape.**
- Attach 3 screws (#72) and 3 rollers (#194).
- Attach 2 screws (#132) and 2 stopper rubbers (#195).
- Fix the MR head with 2 screws (#124). (ref. Fig.2)

INSPECTION AND ADJUSTMENT FOR THE WAVEFORM OUTPUT FROM MR ENCODER

● In case of disassembling or replacing the MR head, be sure to make an adjustment.

1. Equipment and tools required

- Single output rated voltage power supply: 1 unit With 5.0V and 100mA, applicable to the self-made tool
- Oscilloscope: 1 unit
- Self-made tool: 1 unit

Note: In case of any trouble in continuity between the self-made tool and the contacts of relay FPC, there may be dust, corrosion or oxidation on the contact surface of relay FPC. Be sure to polish the contact surface before getting connected to the self-made tool.

2. Preparation for measuring lens

- Connect the fixed tube, on which the MR head and magnetic tape unit were attached, to the measuring devices. (Refer to the next page.)

• Connection diagram

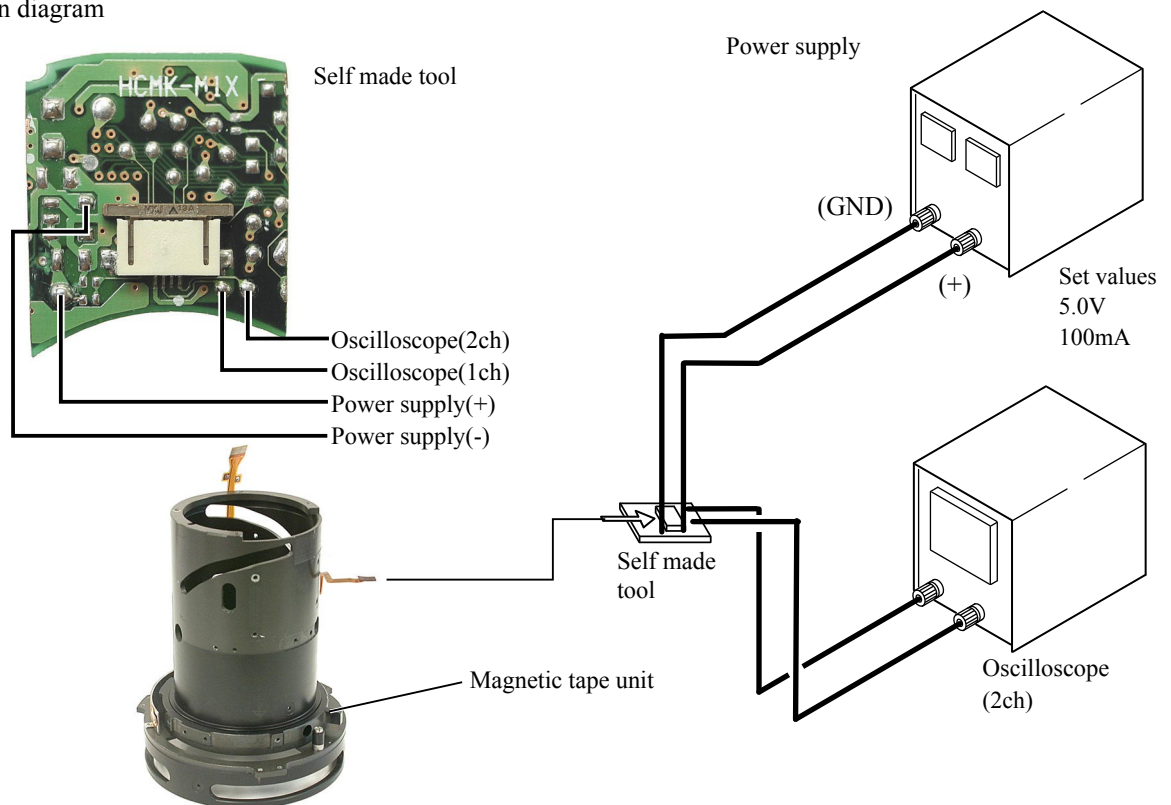

• How to make an inspection and adjustment

- ① Make sure that the current and voltage of the connected rated voltage power supply are set values. Then, turn the power on.
- ② Set the oscilloscope and turn the magnetic tape unit by hand.

Note : Because the shape of waveform varies according to the driving speed of magnetic tape unit, set Time/Div accordingly.

- ③ In case of detecting any wide waveform noise, use the filter function.

How to set the filter function by Yokogawa-manufactured DL1540

1. Press the filter button.
2. Select "Smooth" in the menu on the PC screen.

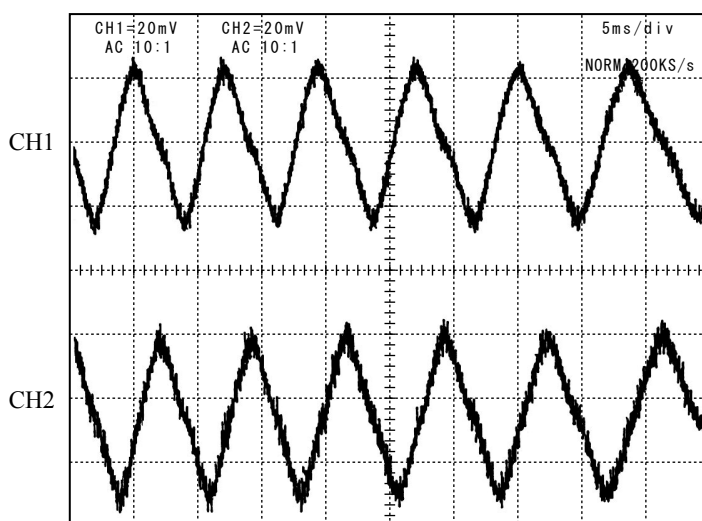

●Setting of oscilloscope

V/Div (CH1)	: 20 mV
V/Div (CH2)	: 20 mV
Coupling	: AC
Time/Div	: 5 m Sec
Trigger Mode	: NORMAL
Trigger Coupling	: AC
Trigger Source	: CH1
Trigger Position	: + 4div
Trigger Type	: EDGE
Trigger Level	: 0 V
INPUT (ch1)	: AC
INPUT (ch2)	: AC

Standard : The amplitude of every pulse/waveform should be 50mV or more.

Note : Check the waveform by letting the focus ring to travel from the infinity-end to the near distance-end and vice versa.

- ④ In the case of smaller amplitude, loosen 2 screws (#123) to move the MR head for adjustments as shown in Fig.1. Magnetic tape

Note: During adjustment, prevent the magnetic tape and MR head from touching the magnetized driver bit. Otherwise, the magnetic data may be damaged.

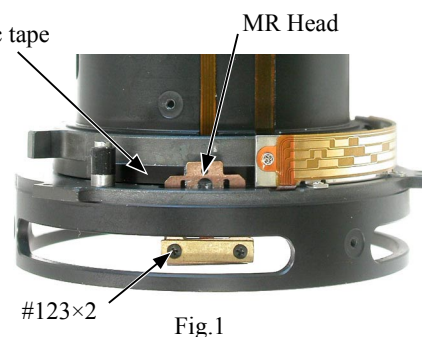

Fig.1

《Reference》

- In case the amplitude of either CH1 or CH2 is smaller, one of 2 screws (#123) may be loosened, so check for it. But if this is not the case, the MR head is regarded as malfunctioning. Be sure to replace the MR head unit and adjust it again.

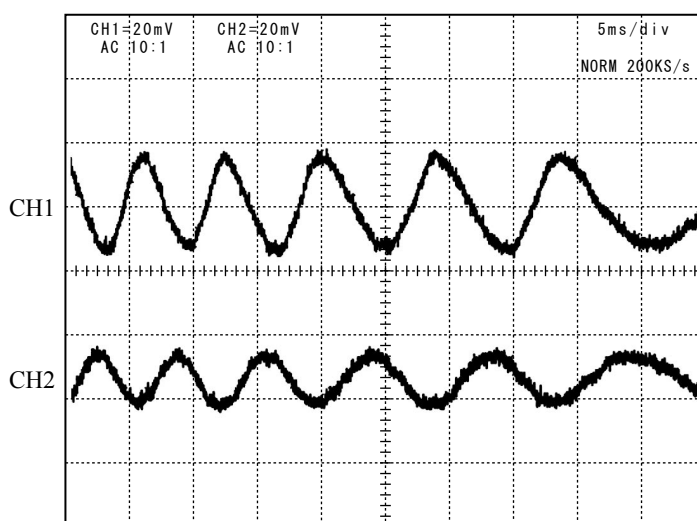

Fig.2

- In case there is a partial drop in the amplitude between the infinity and the near distance, the magnetic data of magnetic tape may be damaged. Then, replace the magnetic tape and adjust it again.

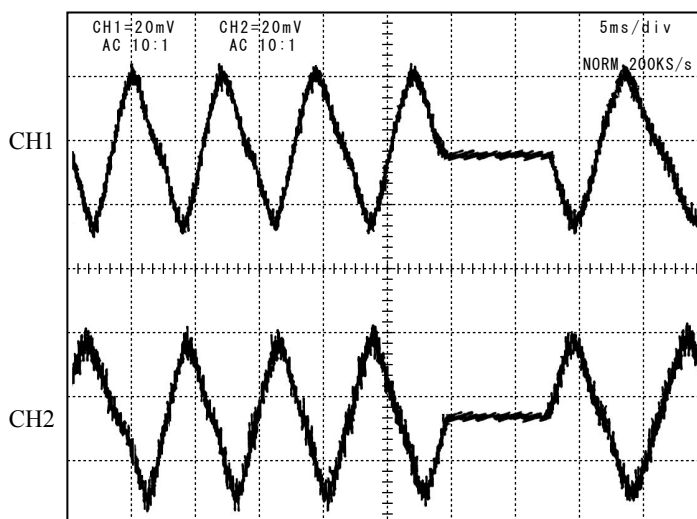
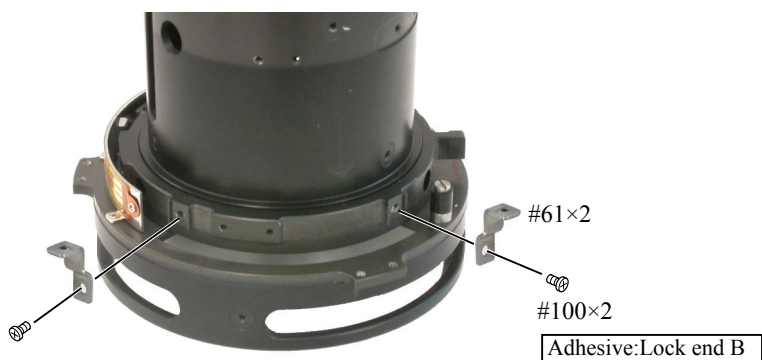

Fig.3

- ⑤ Turn off the rated voltage power supply.

DISTANCE SCALE PLATE MOUNTING-BASE



DISTANCE ENCODER BRUSH

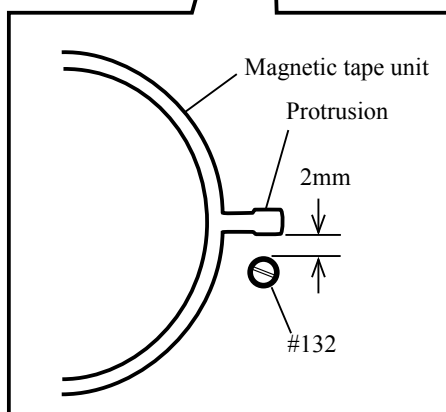
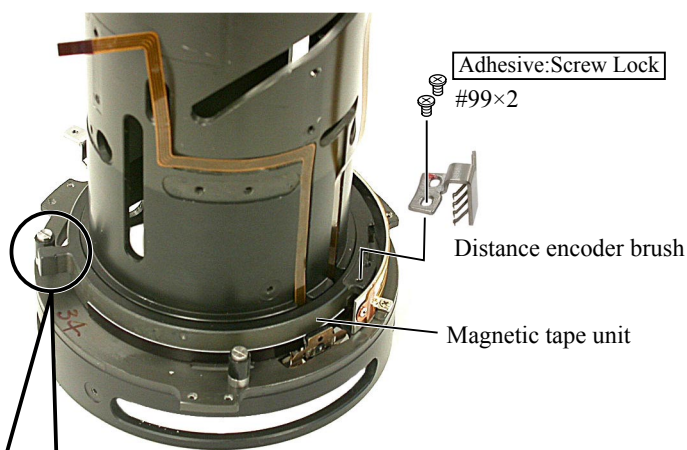
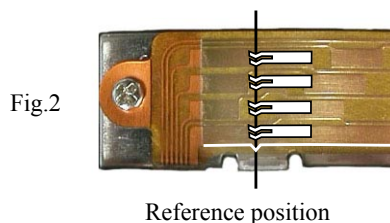

Fig.1

- Attach the distance encoder brush on the magnetic tape unit with temporarily 2 screws (#99).
- Turn the magnetic tape unit so that the distance between the protrusion and stopper rubber (#132) becomes 2-mm. (ref. Fig.1)
- Adjust so that the contact face of the brush becomes the reference position (ref. Fig.2). After tightening 2 screws (#99), apply Screw lock.



SWM UNIT

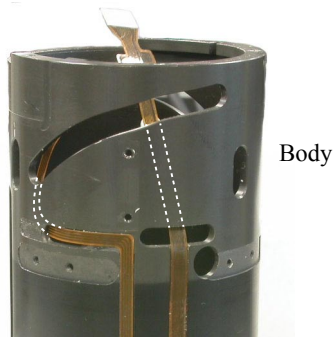

Fig.1

FPC

- Pass the FPC through the hole as shown in Fig.1, and put it into the lens body in position.



SWM

#161

#160

- Attach the SWM connecting key (#162) to the magnetic tape unit with 2 screws (#100).
- Put the washer (#160) and wave washer (#161) on.
- Assemble the SWM and engage the shoulder screw of the SWM in the SWM connecting key. (ref. Fig.2)
- Attach 3 screws (#158) and 3 rollers (#159). (ref. Fig.3)
- Take out the FPC which was put into the lens body.

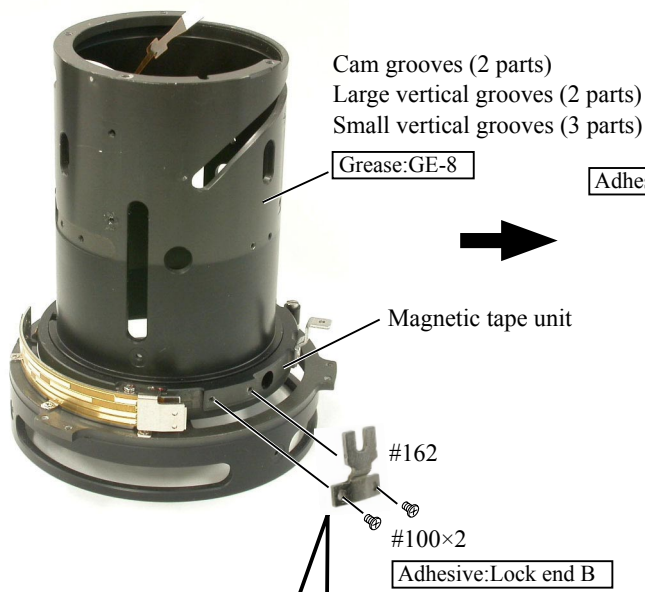

Cam grooves (2 parts)

Large vertical grooves (2 parts)

Small vertical grooves (3 parts)

Grease:GE-8

Magnetic tape unit

#162

#100x2

Adhesive:Lock end B

Adhesive:Lock end B

#158x3

#159x3

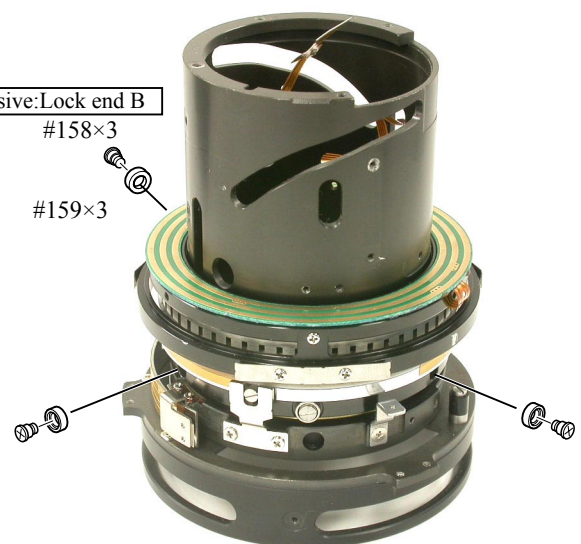
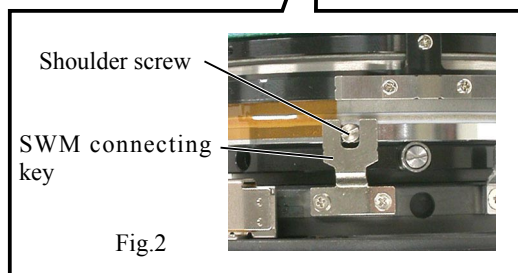

Fig.3



Shoulder screw

SWM connecting key

Fig.2

CAM RING GROUP

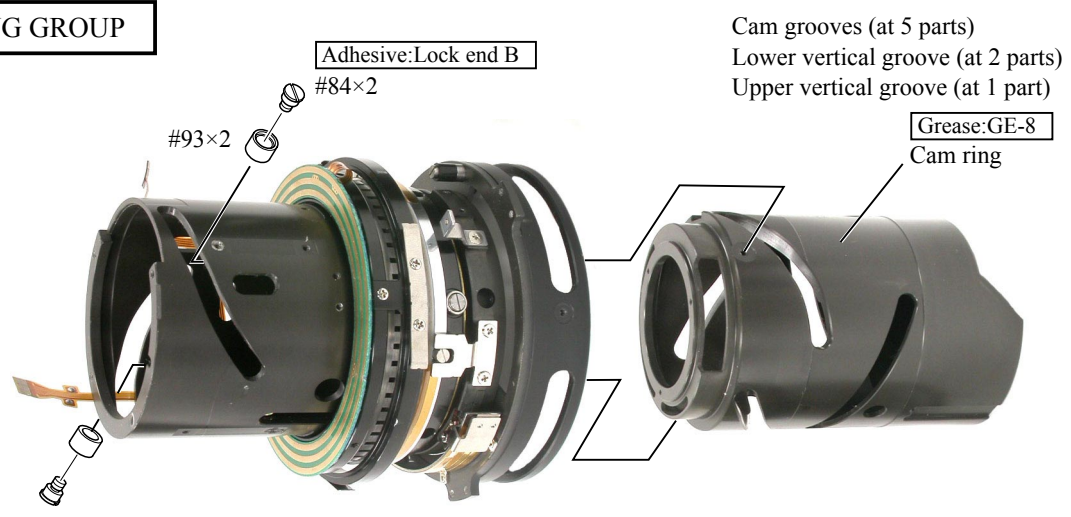

APERTURE BLADE HOUSING UNIT, 3RD LENS GROUP

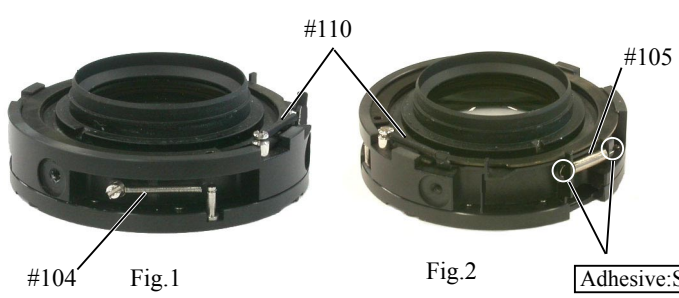
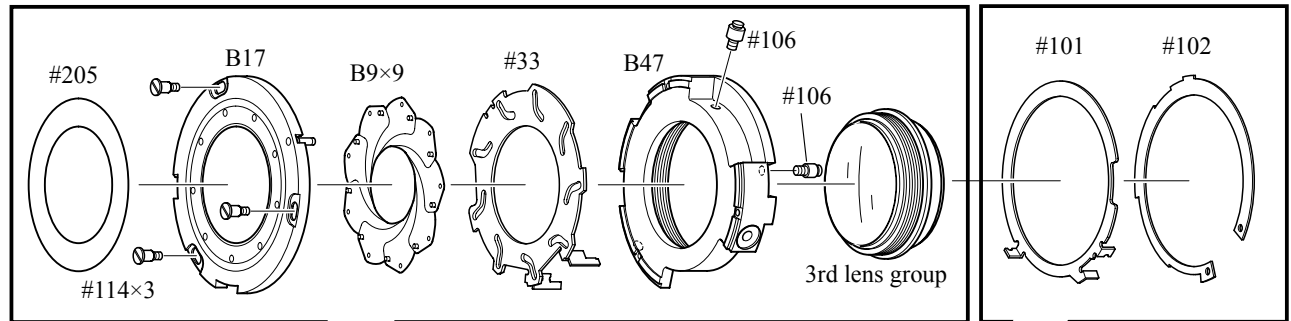

- Hook the spring to the assembled aperture blade housing unit. (at 3 parts) (ref. Fig.1 and Fig.2)
- Apply the screw lock on both ends of the spring (#105). (ref. Fig.2)

ASSEMBLE APERTURE BLADE HOUSING UNIT

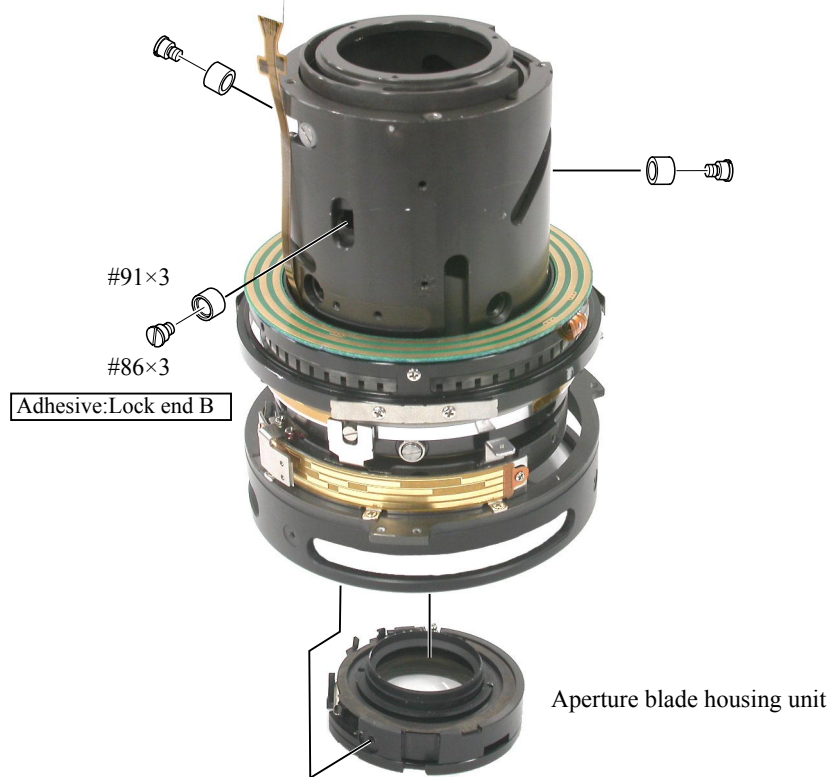

2.5 LENS GROUP

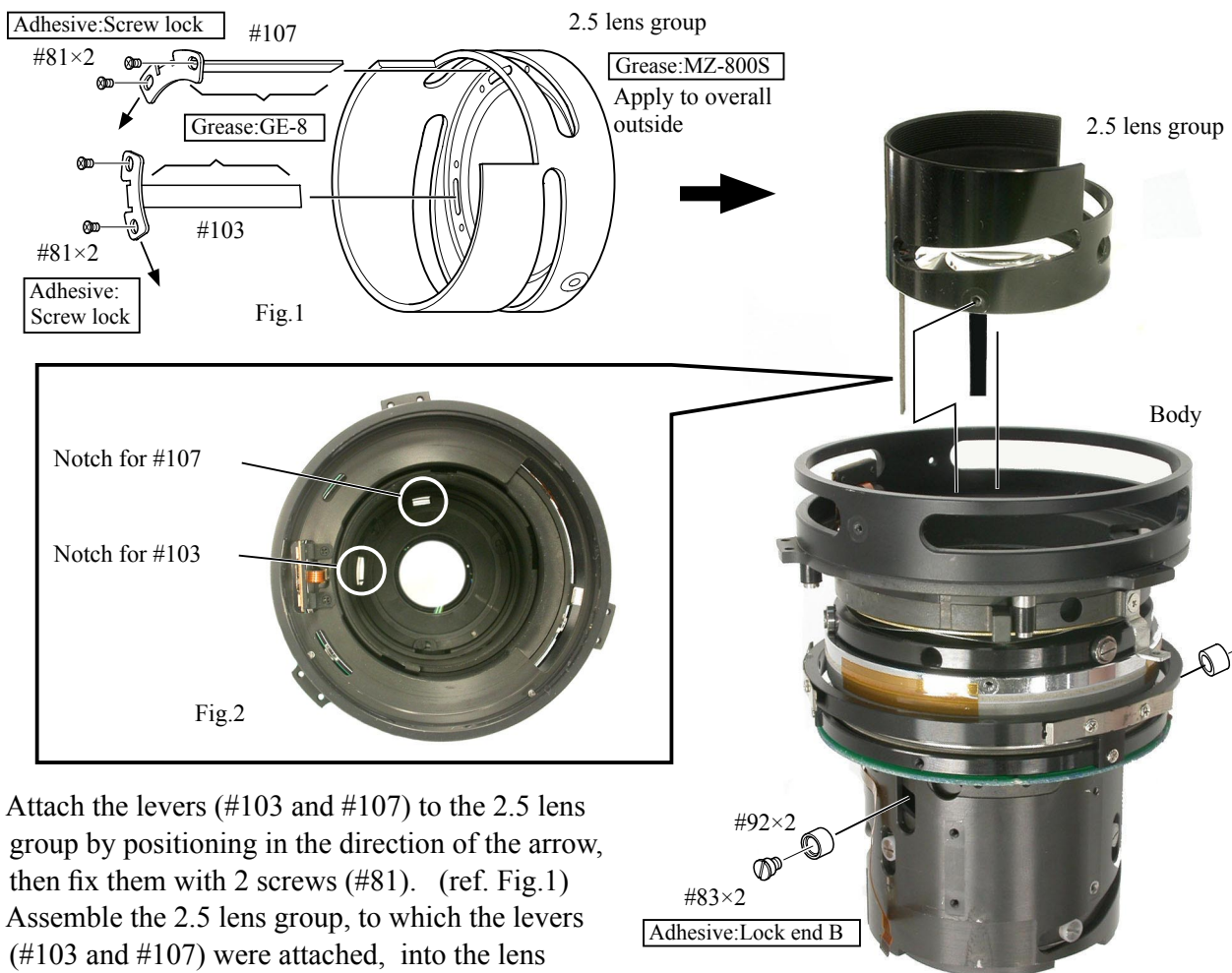

- Attach the levers (#103 and #107) to the 2.5 lens group by positioning in the direction of the arrow, then fix them with 2 screws (#81). (ref. Fig.1)
- Assemble the 2.5 lens group, to which the levers (#103 and #107) were attached, into the lens body by aligning each with its notch. (ref. Fig.2).

FOCUS SLIDING UNIT

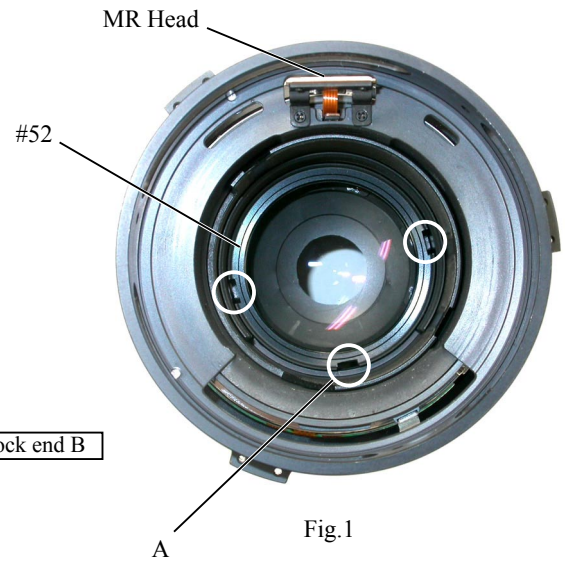
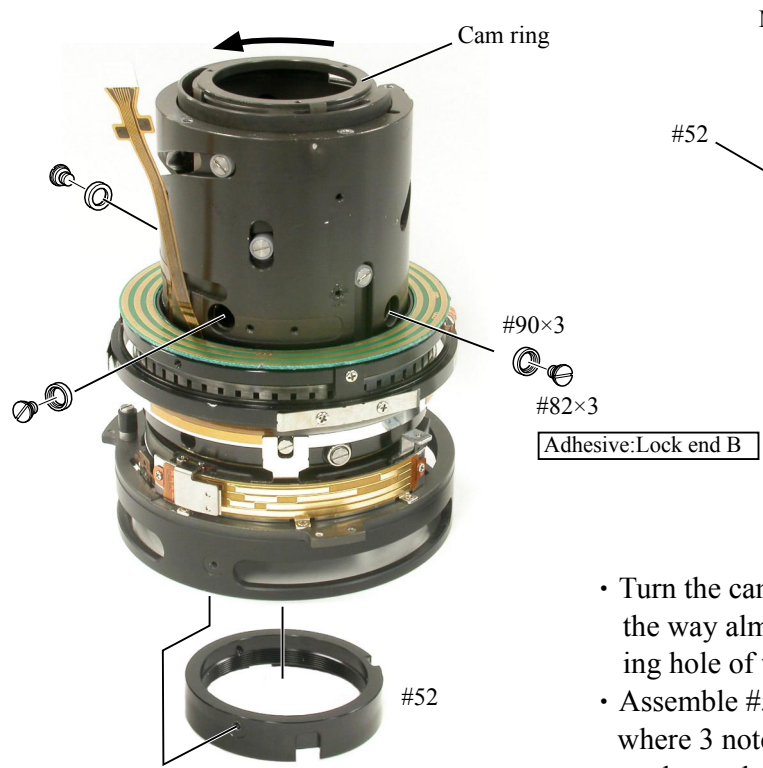

- Turn the cam ring in the direction of the arrow all the way almost to the limit so that the roller mounting hole of the cam ring can be seen.
- Assemble #52 into the lens body at the position where 3 notches (circled in Fig.1) and the MR head are located as shown in Fig.1.



- Attach #52 with 3 screws (#82) and 3 rollers (#90).
Note: Be noted that when the screw (#82) is attached, 3 screw holes of #52 and 3 holes of the body are misaligned. So, fit the positions by moving #52 slightly from side to side.

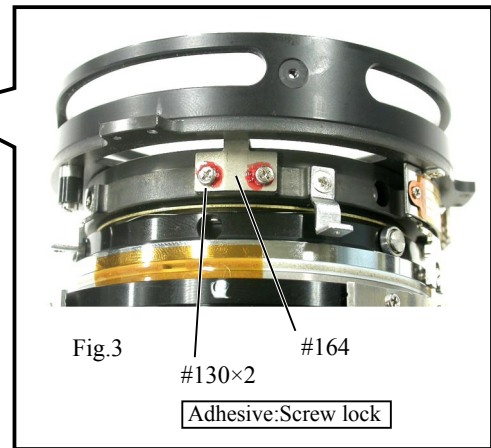
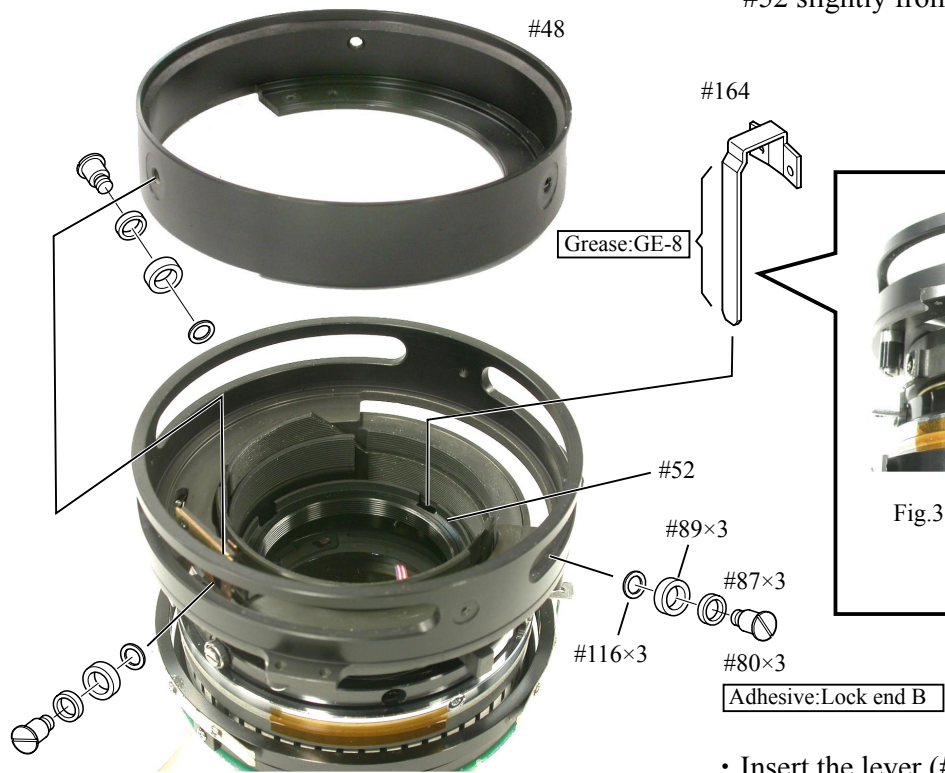

- Insert the lever (#164) into the notches that were shown in "A" of Fig.1. (ref. Fig.2)
- Fix #164 with 2 screws (#130). (ref. Fig.3)
- Assemble #48 into the lens body.

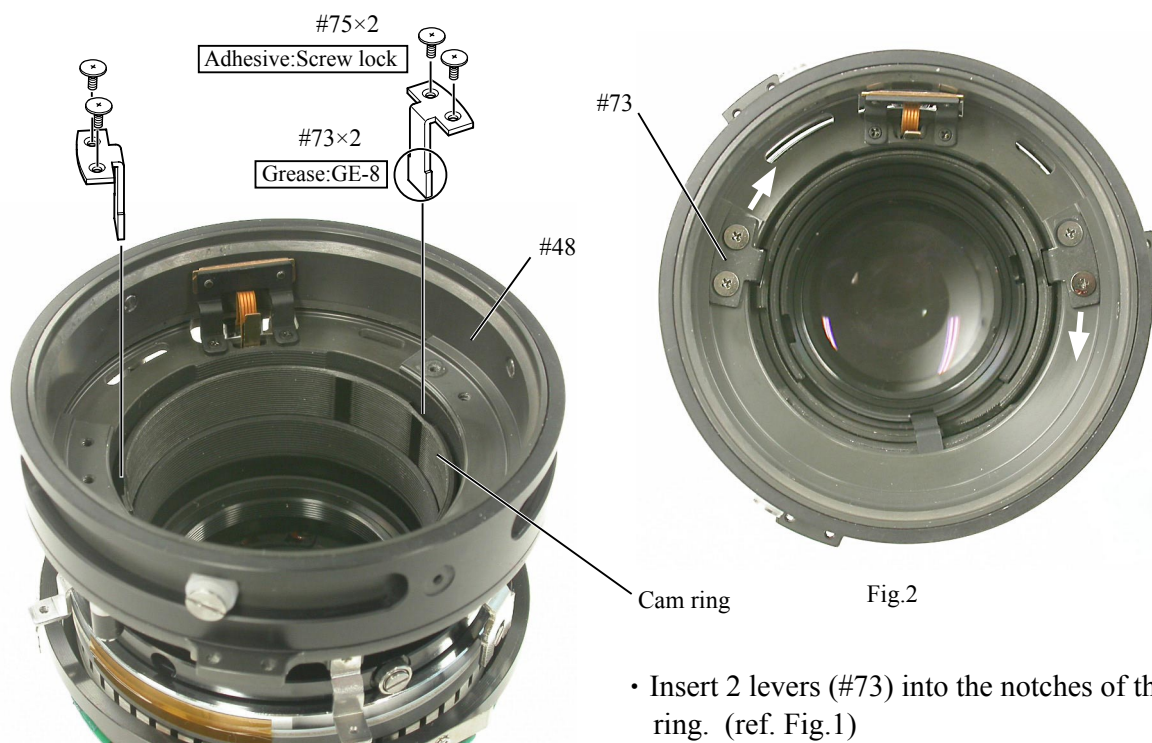
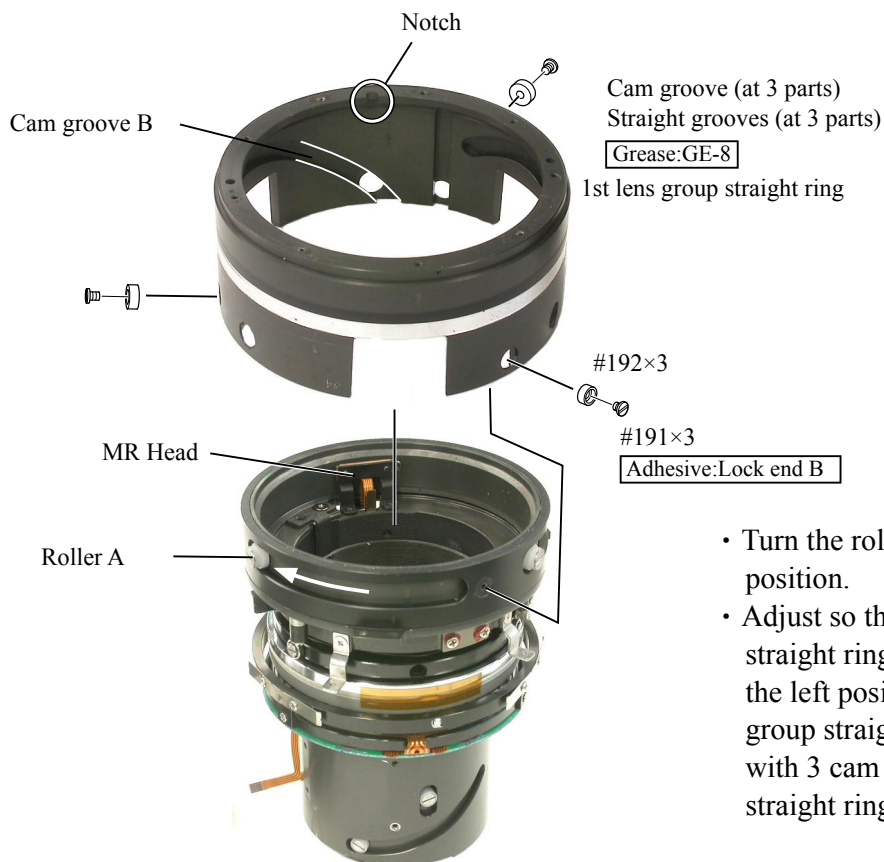

Fig.1

Fig.2

- Insert 2 levers (#73) into the notches of the cam ring. (ref. Fig.1)
- Position 2 levers (#73) by turning clockwise, and fix them with 2 screws (#75). (ref. Fig.2)

1ST LENS GROUP STRAIGHT RING



- Turn the roller A clockwise to the full up position.
- Adjust so that the notch of the 1st lens group straight ring and the MR head are located at the left position, then assemble the 1st lens group straight ring by aligning 3 rollers A with 3 cam grooves of the 1st lens group straight ring.

HOOD-FIX TUBE



DISTANCE SCALE PLATE

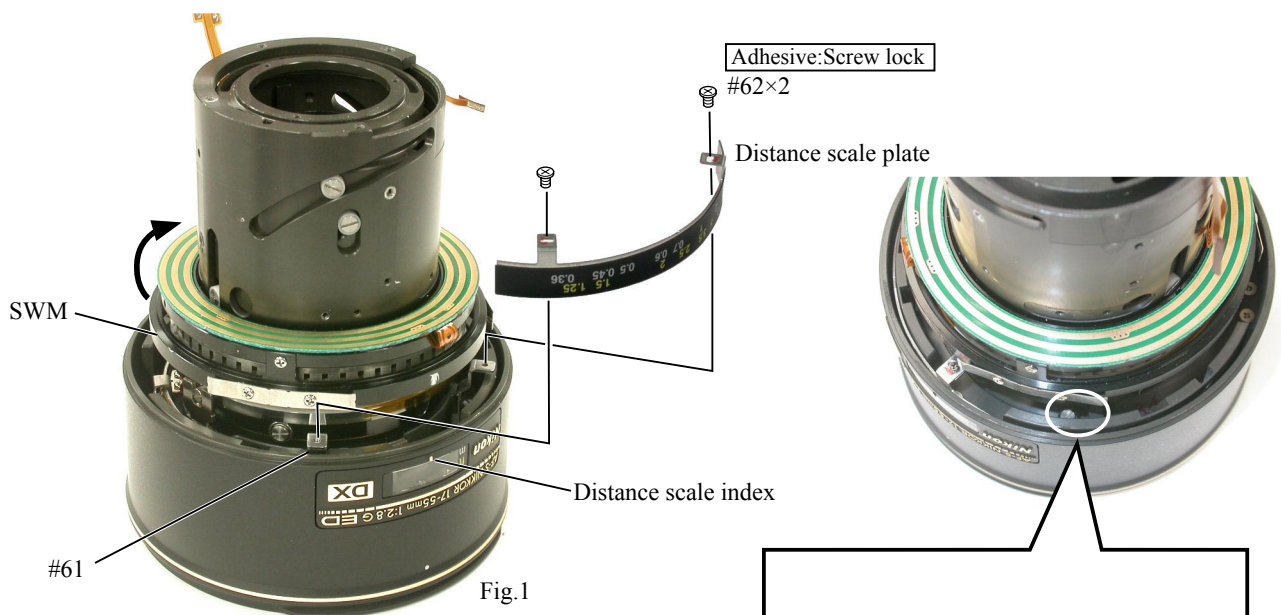

- Attach the distance scale plate to #61 temporarily with 2 screws (#62). (ref. Fig.1)
- Turn the SWM in the direction indicated by the arrow, and adjust so that the distance between the protrusion of the magnetic tape unit and the stopper rubber (#195) becomes 2-mm. (ref. Fig.2) (To leave 2-mm space, use a 2-mm diameter drill.)
- Adjust the position of the distance scale plate so that the distance scale index and "∞" mark are aligned, then fix them with 2 screws (#62).

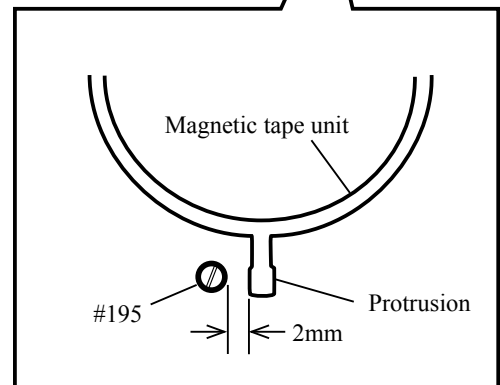

Fig.2

POWER BRUSH

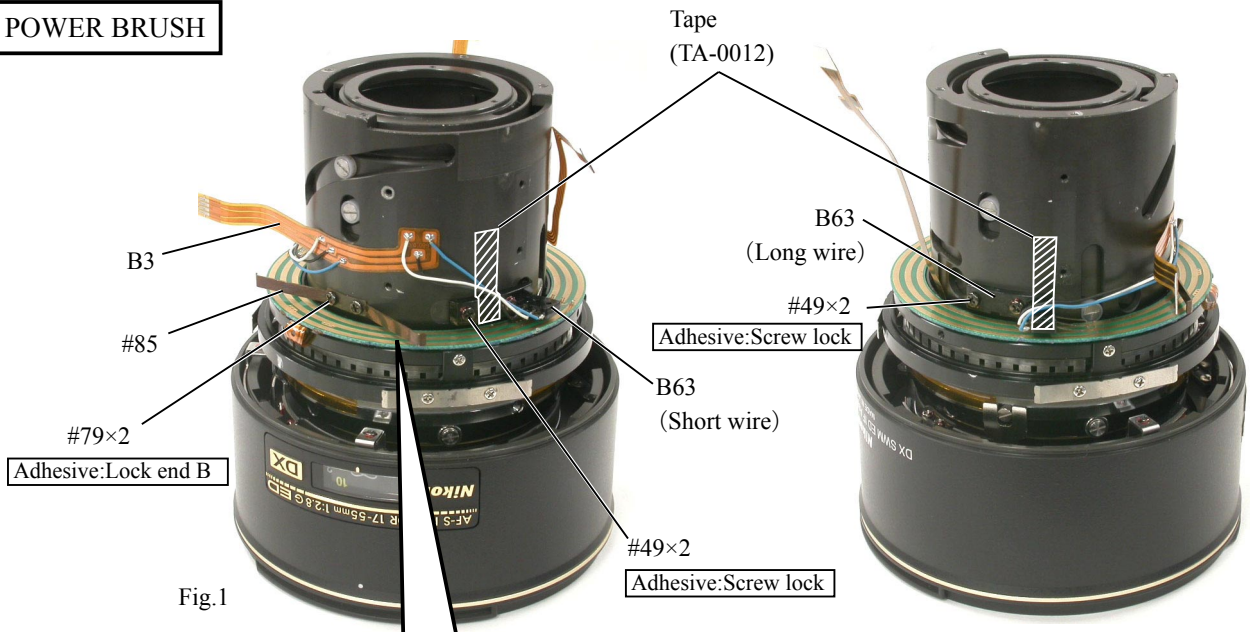

Fig.1

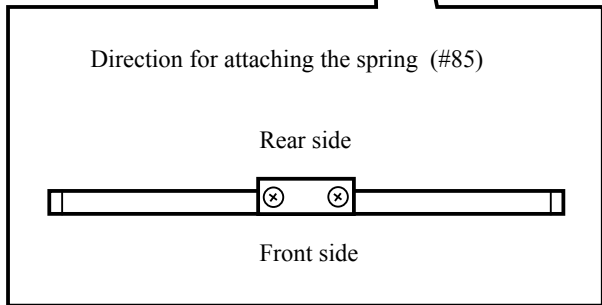

Fig.2

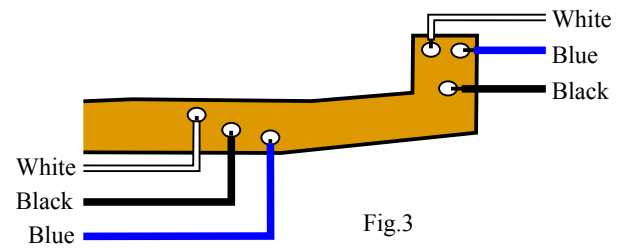

Fig.3

- Attach the spring (#85) with 2 screws (#79). (ref. Fig.2)
- Attach the FPC B3 at the position of Fig.1.
- Attach the power brush B63 (at 2 parts) with 2 screws (#49).
- Solder 6 wires of the power brush on the FPC B3. (ref. Fig.3)
- Fix the wires of the power brush with the tape (TA-0012: 6mm×20mm).

M/A BRUSH

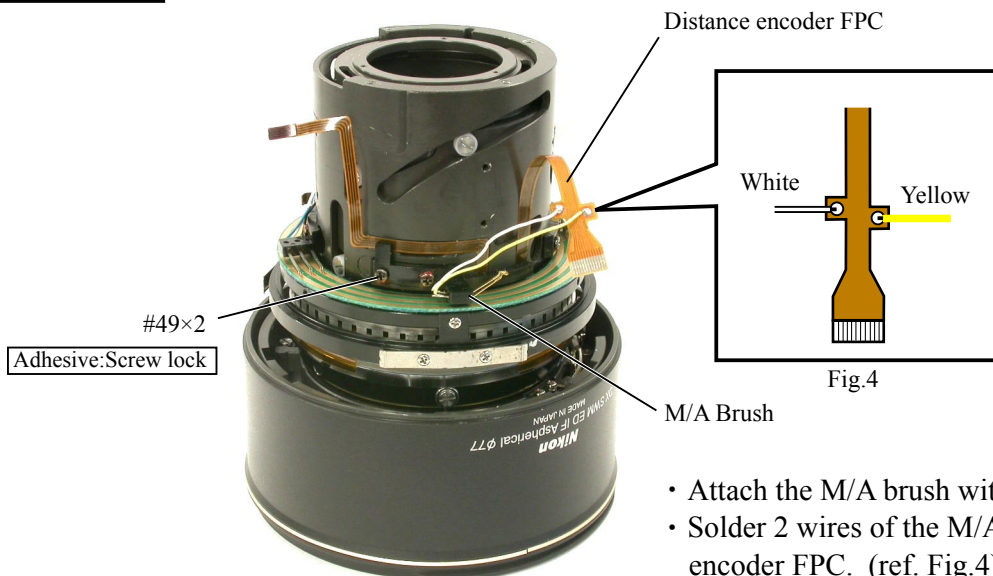

Fig.4

- Attach the M/A brush with 2 screws (#49).
- Solder 2 wires of the M/A brush on the distance encoder FPC. (ref. Fig.4)

FOCUS RING



Focus ring

Grease: MZ-800S

Apply to the overall inside

- Assemble the focus ring while setting aside the spring (#85).
- After the assembling, turn the focus ring to confirm that the distance scale rotates accordingly.

If the distance scale slips on the way, change thickness of the washer (#160). (ref. Page L24)

ZOOM ENCODER FPC



- Attach the zoom encoder FPC by positioning it in the direction of the arrow.

MAIN PCB

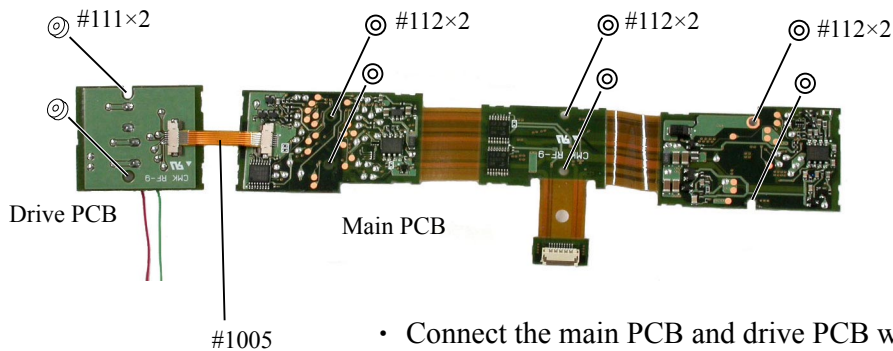

- Connect the main PCB and drive PCB with FPC (#1005).
- Put 6 spacers (#112) on the main PCB, and 2 spacers (#111) on the drive PCB.

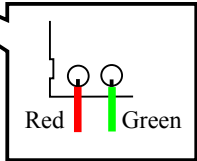
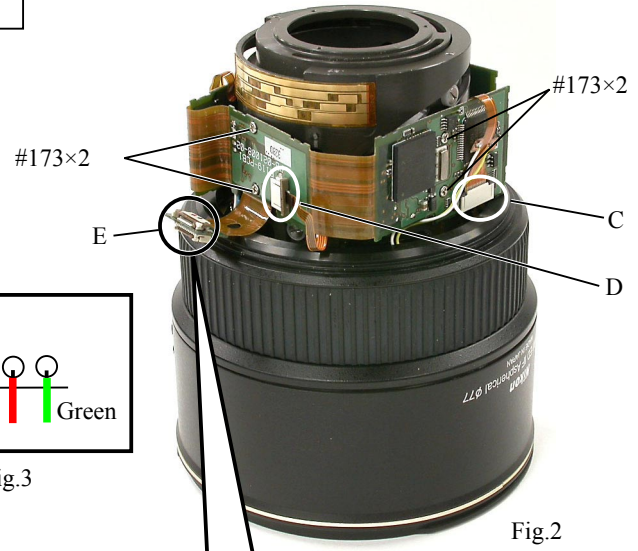

- Attach the main PCB as shown in Fig.1 and Fig.2, and fix them with the screw (#133), 5 screws (#173) and 2 screws (#174).
- Connect 4 connectors (A-D).
- Solder 2 parts. (ref. Fig.3)
- Put the connector E in position as shown in Fig.4.



M/A SELECTOR SWITCH

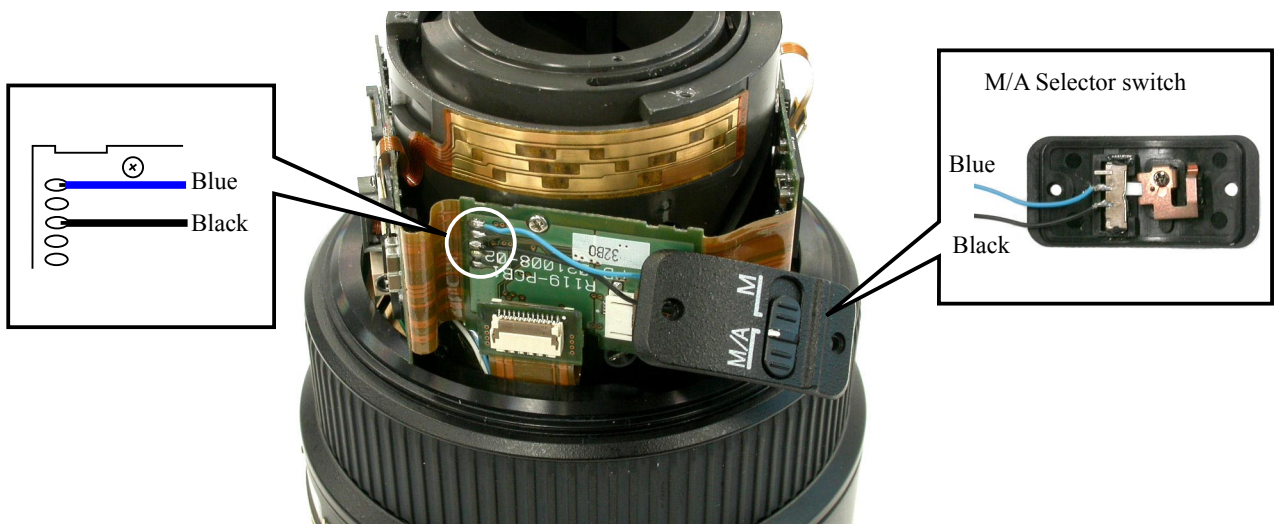



- Attach the tape (TA-0002: 20mm×100mm) on the main PCB at the left position.

LIGHT-SHIELDING SHEET

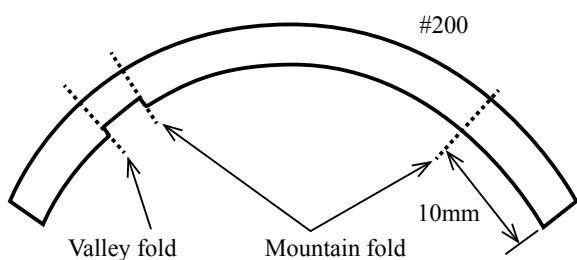

Fig.1

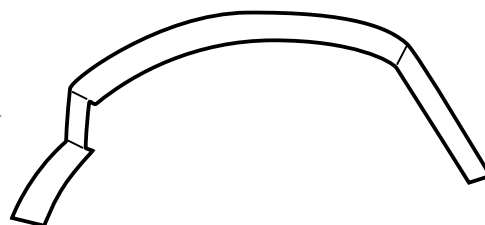

Fig.2

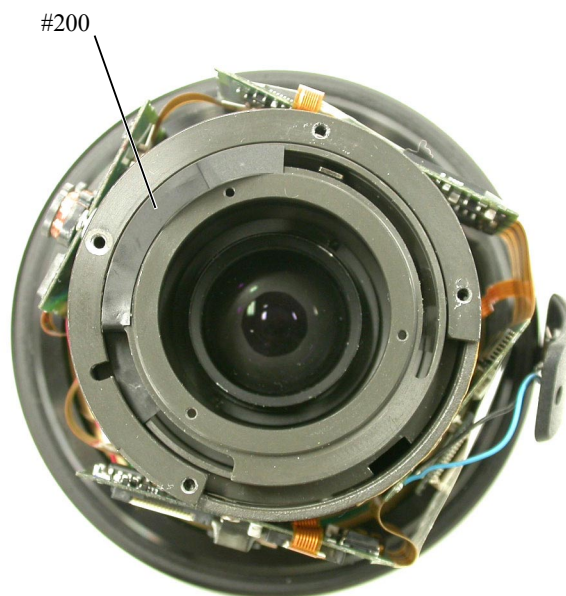
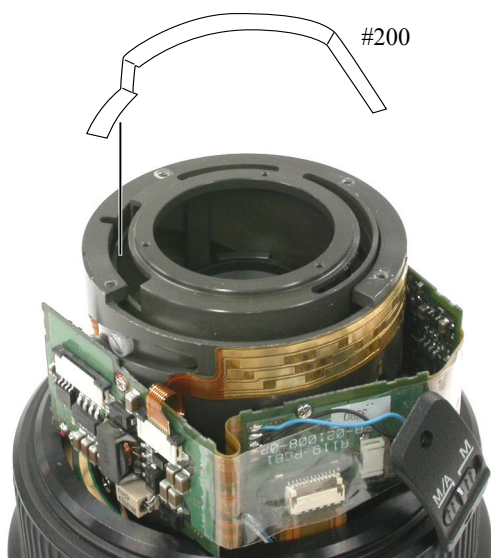
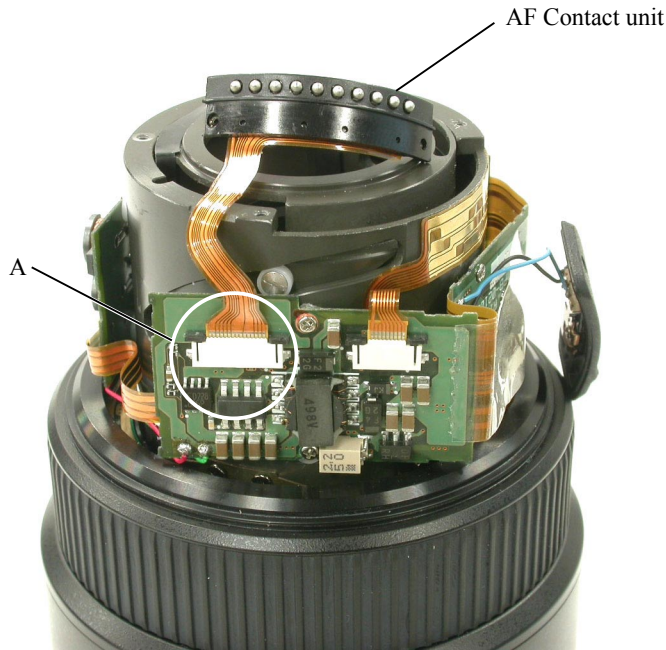

Fig.3

- Fold the light-shielding sheet (#200) at the position of Fig.1, to become like Fig.2.
- Attach the light-shielding sheet (#200) as shown in Fig.3.

AF CONTACT UNIT



- Put the FPC of the AF contact unit in the connector A of the main PCB.

ZOOM RING

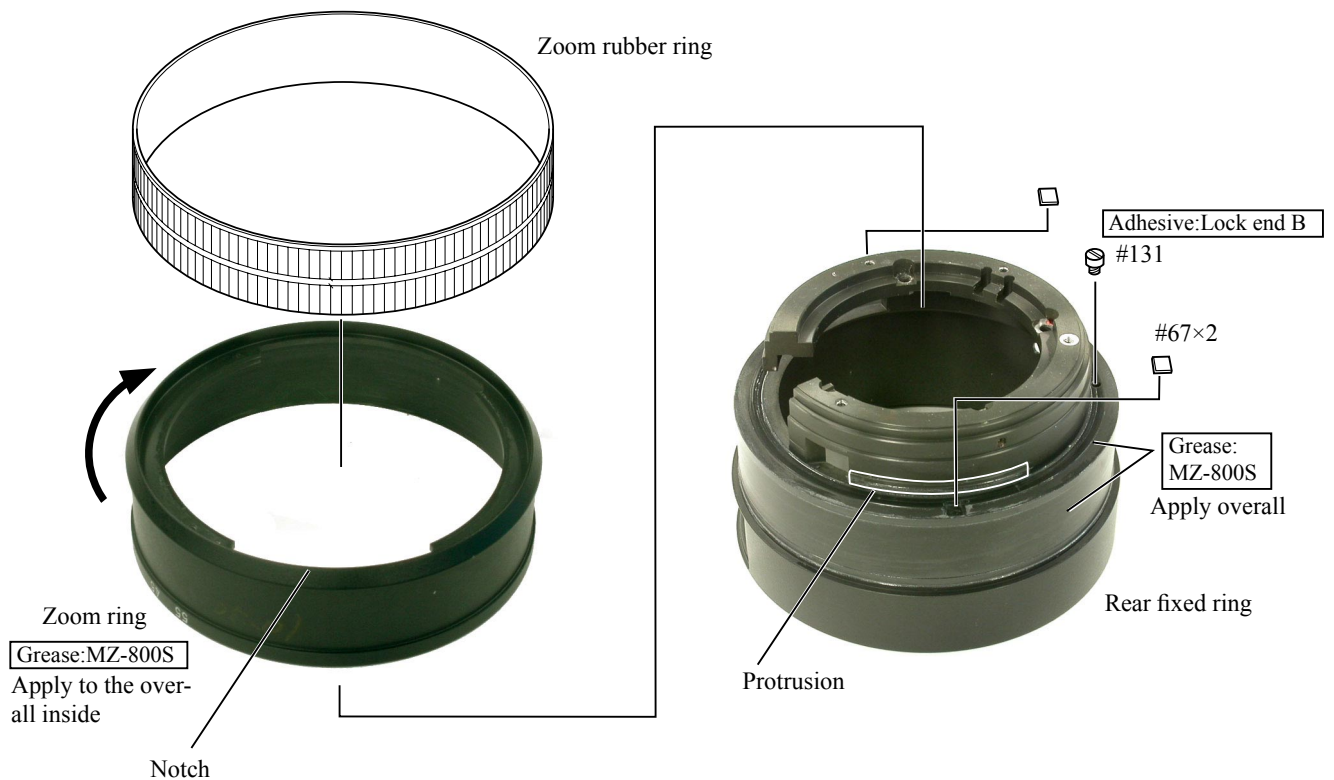

- Attach 2 zoom ring retainers (#67) on the rear fixed ring.
- Align the notch of the zoom ring with the protrusion of the rear fixed ring to assemble them, and turn the zoom ring in the direction indicated by the arrow.
- Attach the screw (#131).

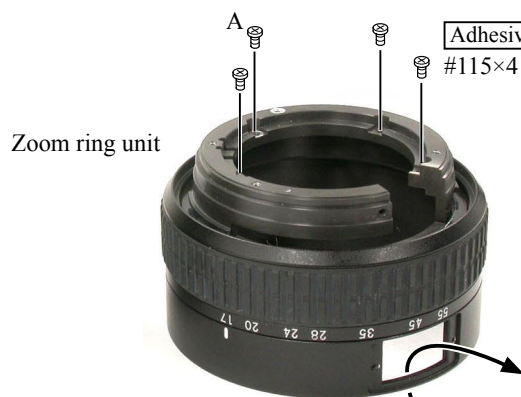

- Put the washer (#169) on.
 - Pass the M/A selector switch through the hole of the zoom ring unit.
 - Assemble the zoom ring unit into the body at the left position, then fix them with 4 screws (#115).
- Note: Do NOT apply Screw lock on the screw A, because it is used for earthing.

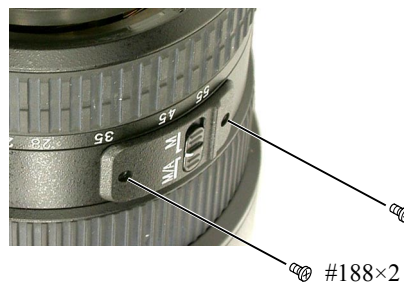

ZOOM CONNECTING PLATE

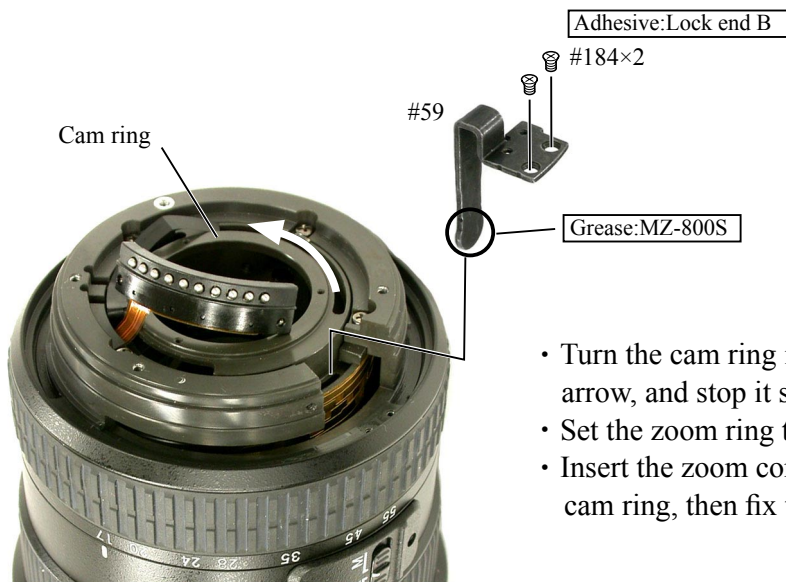

- Turn the cam ring in the direction indicated by the arrow, and stop it slightly short of the limit.
- Set the zoom ring to WIDE-end.
- Insert the zoom connecting plate into the hole of the cam ring, then fix them with 2 screws (#184).

ZOOM ENCODER BRUSH

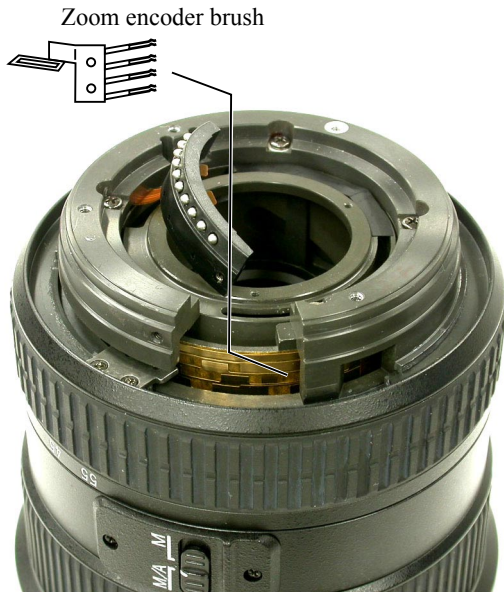

Fig.1



Fig.2 Confirmation hole

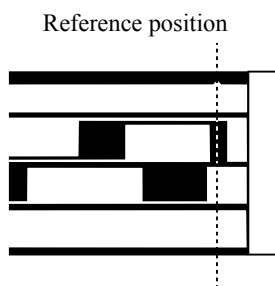

Fig.3

- Set the zoom ring to 28-mm, and insert the zoom encoder brush in it. (ref. Fig.1)
- Set the zoom ring to 17-mm, and attach the zoom encoder brush temporarily with 2 screws (#96). (ref. Fig.2)
- Check the position of the brush through the confirmation hole (ref. Fig.2), and adjust the contact face of the brush so that it becomes the reference position as shown in Fig.3.
- After the adjustment, fix 2 screws (#96) with Screw lock.

INDEX RING



4TH LENS GROUP

【Adjust clearance between G10 lens and G11 lens】

TELE Δ (Revision)

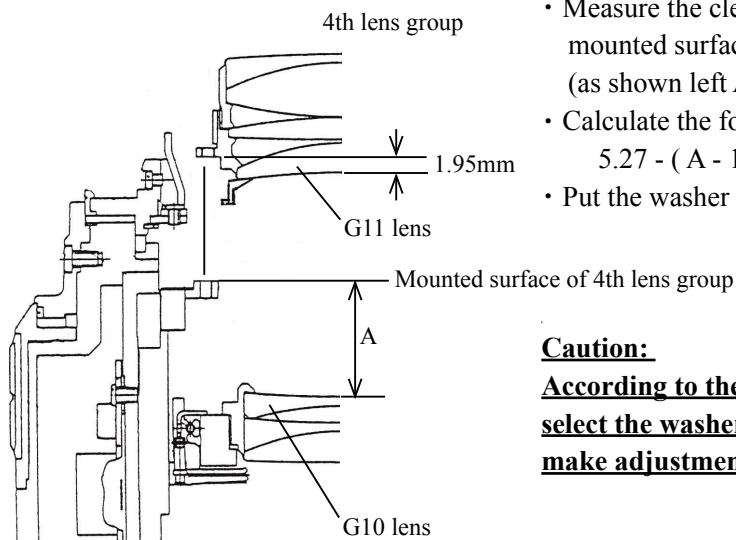

- Turn the zoom ring to **WIDE**-end, and set the lens on the measurement stand.
- Measure the clearance between R2 surface of G10 lens and the mounted surface of the 4th lens group with digital micrometer. (as shown left A)
- Calculate the following in millimeter.

$$5.27 - (A - 1.95) = \text{Size of washer (\#47)}$$
- Put the washer (\#47) just under the 4th lens group.

Caution: Δ (Addition)

According to the result of the projection resolution test, select the washer (\#47) from 1K103-087 to 1K103-095, and make adjustment.

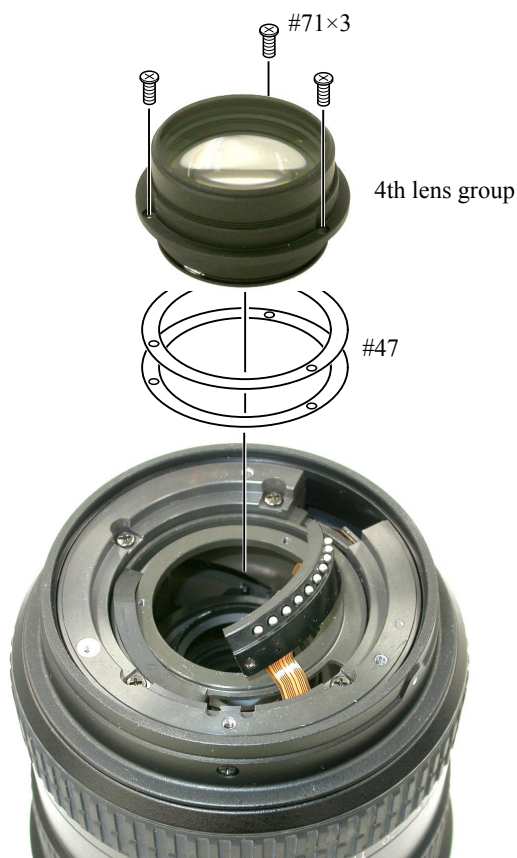

Fig.1



Fig.2

- Assemble the 4th lens group and washer (\#47) temporarily with 3 screws (\#71). (ref. Fig.1)
- Insert the "wrench for 4G AF-S 17-55DX" (J11305) to position the 4th lens group, then fix with 3 screws (\#71). (ref. Fig.2)



BAYONET MOUNT

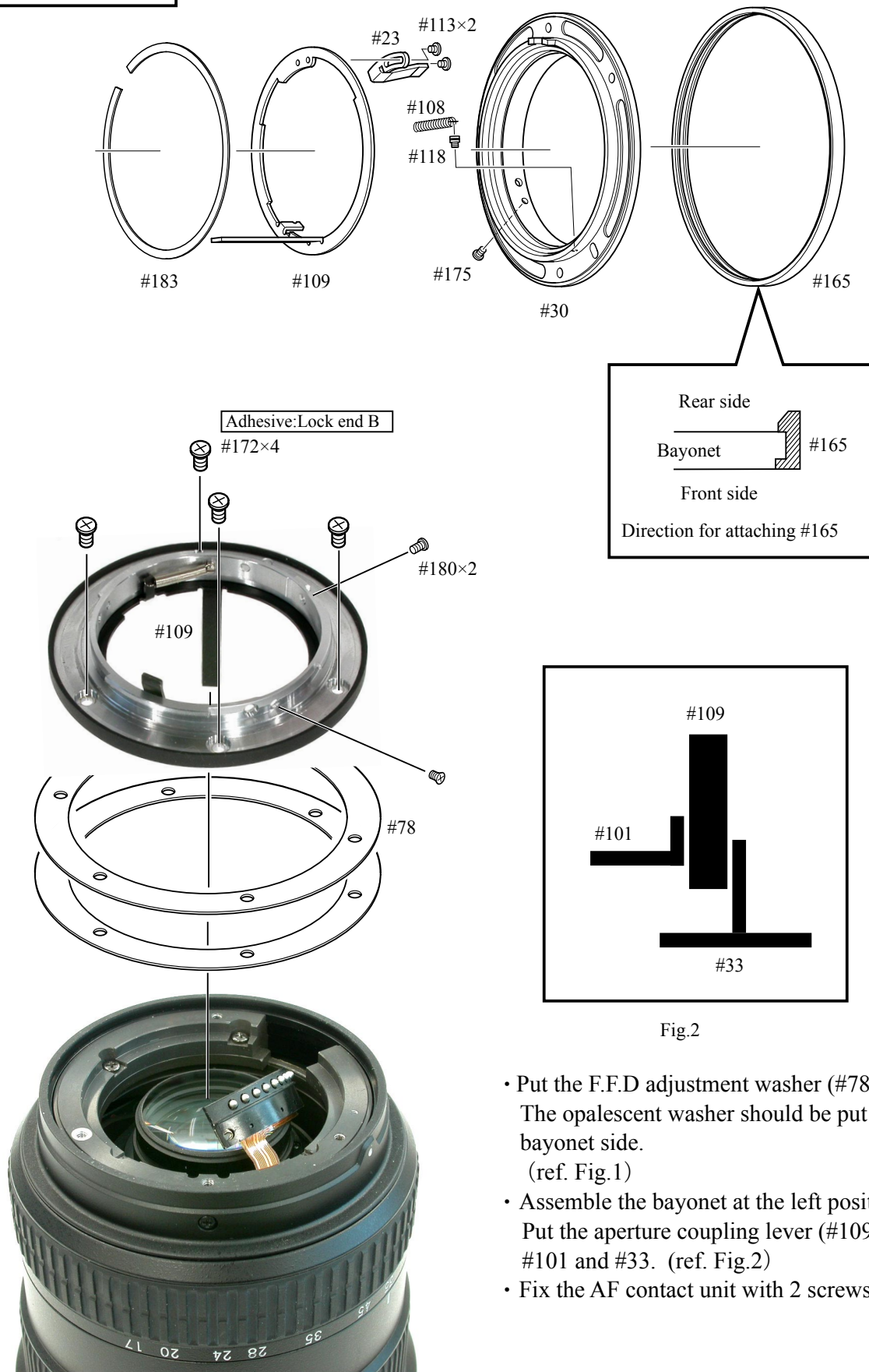

Fig.1

Fig.2

- Put the F.F.D adjustment washer (#78) on the body. The opalescent washer should be put on the bayonet side. (ref. Fig.1)
- Assemble the bayonet at the left position. Put the aperture coupling lever (#109) in between #101 and #33. (ref. Fig.2)
- Fix the AF contact unit with 2 screws (#180).

2ND LENS GROUP



- Set the focus ring to close-end, and the zoom ring to slightly 35-mm side from 28-mm.
- Mount J11303B by aligning with the notches of the cam ring, then insert the pin (J11303C) into the hole of J11303B. (ref. Fig.1)
- Attach the 2nd lens group with wrench for 2G AF-S 17-35 DX (J11303A). (ref. Fig.2)

1ST LENS GROUP

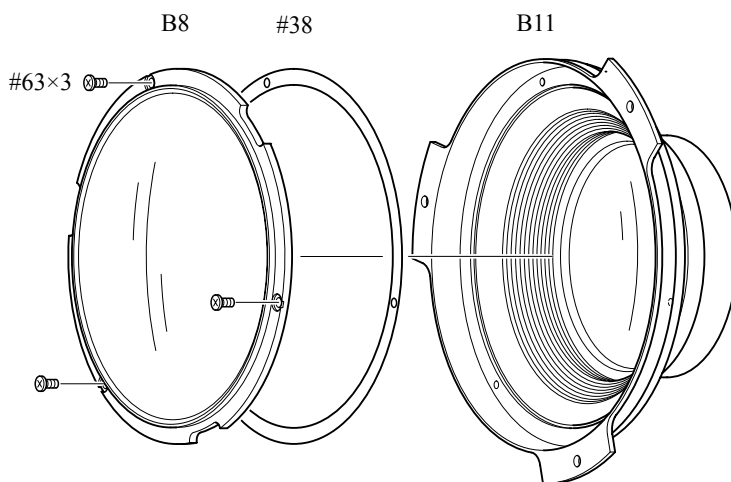

- The washer (#38) should be 0.5- mm (fixed) in thickness.

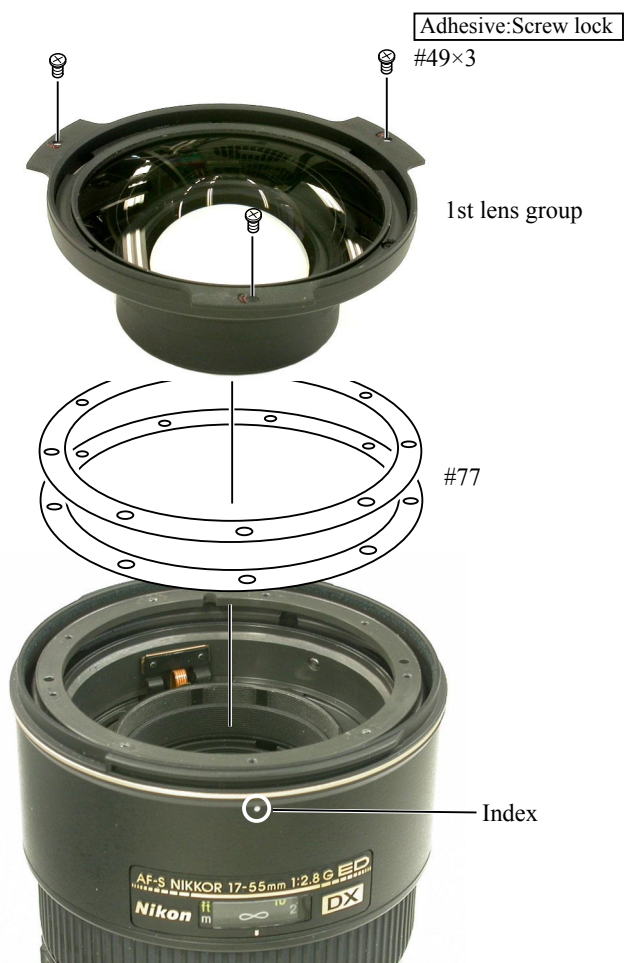

- Put the washer (#77) on.
- Align one of 3 protrusions of the 1st lens group with the index to assemble the 1st lens group, then fix them 3 screws (#49).

ADJUSTMENT OF APERTURE DIAMETER

J18004-1

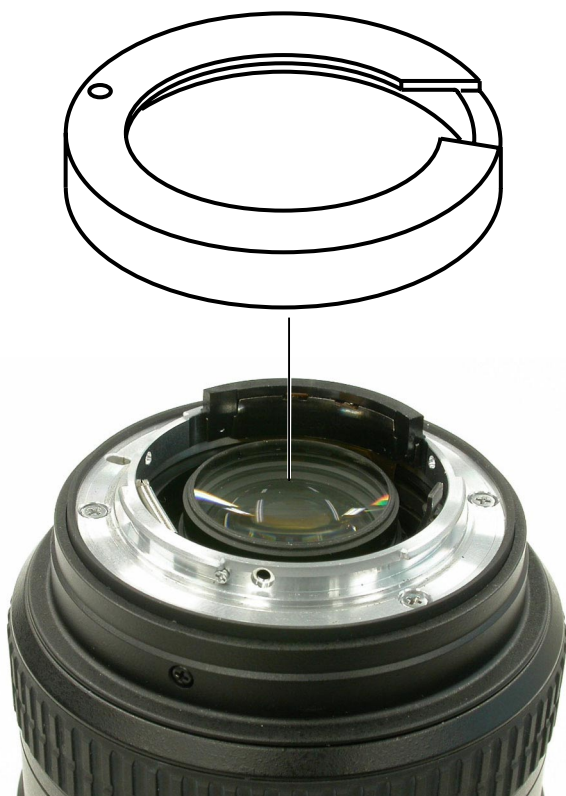

- Set the zoom ring to TELE side.
- Set the tool (J18004-1) and check the aperture diameter.

Standard: Full aperture

- If it is out of the standard, adjust the position of the aperture lever by loosening 2 screws (#113).

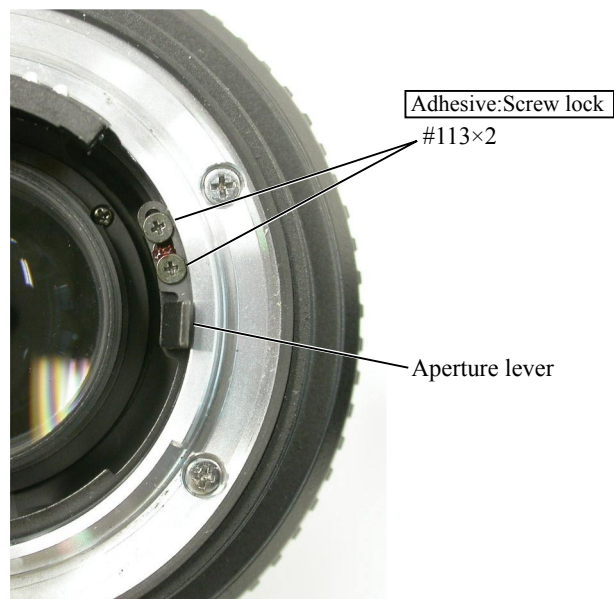

ADJUSTMENT OF FOCUS MOVEMENT (TELE, WIDE) /SLANT ADJUSTMENT

1. Align the infinity (∞) mark of the focus ring with the index.
2. Fix the aperture lever so that the aperture becomes "full".
3. Read the values of the Wide and Tele sides.
4. Carry out the following calculations.

$$(A - B) \div 2.5 = C$$

A = Value of Tele side

B = Value of Wide side

C = Adjustment amount (mm) of the 1st lens group unit washer (#77).

5. Adjust the thickness of the washer (#77) by the value of C calculated in the above. If C is positive, increase the washers to thicken. If it is negative, decrease the washers to thin. (Refer to P. L40.)

Note: When putting the washers (#77), put a thin washer between thick washers.

ADJUSTMENT OF BACK FOCUS

1. Align the infinity (∞) mark of the focus ring with the index.
2. Fix the aperture lever so that the aperture becomes "full".
3. Read the value of Wide or Tele side.
4. Remove the bayonet mount.
5. Adjust the thickness of the washer (#78) by the difference from the standard value. If the difference value is positive, increase the washers to thicken. If it is negative, decrease the washers to thin. (Refer to Page L38.)

Focal length (f)	Standard (mm)
17mm	0 ~ +0.06
35mm	0 ~ +0.06
55mm	0 ~ +0.25

1ST LENS GROUP ALIGNMENT

Adhesive:Screw lock

#63×3



1. Position the 4th lens group with J11305. (ref. Page L37)
2. Fix the aperture lever so as to become full aperture.
3. Set the zoom ring to TELE side, and the focus ring to "∞".
4. Set the lens to the point tester.
5. Check the optical axis. If it is the case other than Fig.1 ①, loosen 3 screws (#63) and adjust G1 lens as shown in Fig.2.
6. If it becomes like ①, fix G1 lens with 3 screws (#63).

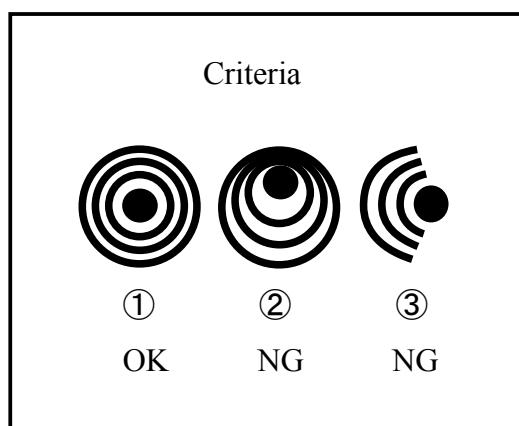
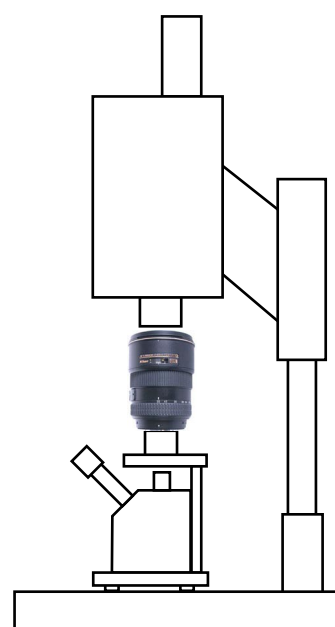

Fig.1



Point tester

Optical axis				
G1 lens Moving direction				

Fig.2

【In case 193.5-mm Collimator is used】

(1) Device

- 193.5-mm Collimator
- AF-S17-55 front-lens-group center alignment stand (J19130)
- MEGALIGHT 100 (included in the periphery alignment equipment (J19125))
- Pinhole chart (included in the center alignment equipment (J19126))

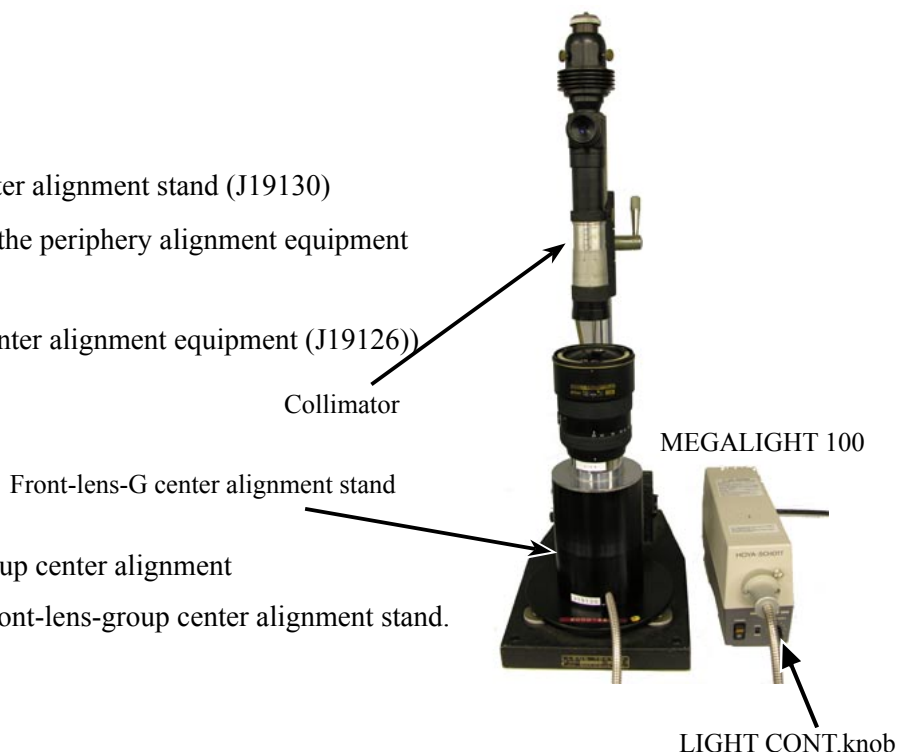

(2) Prepare Stand for front lens group center alignment

- Attach the pinhole chart to the front-lens-group center alignment stand.



- Insert the fiber-optic cable that comes from MEGALIGHT 100 into the pinhole chart.

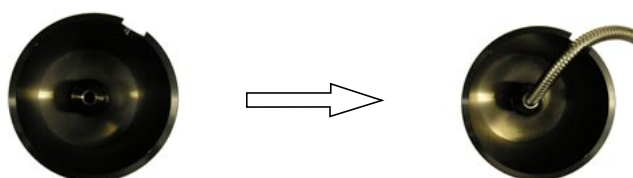

(3) 1st Lens group alignment

- 1) Position the 4th lens group with the 4th lens alignment tool (J11305). (ref. Page L37)
- 2) Mount the lens to be inspected by aligning its index with "△"-mark of the stand. Then turn the lens to "●" so that the aperture is fully open.

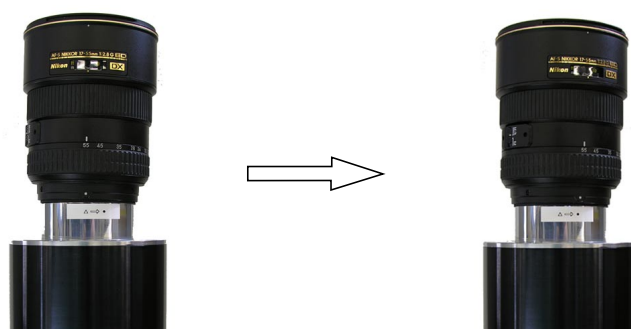

- 3) Set the zoom ring to Tele-side.
- 4) Turn the power of "MEGALIGHT 100" to ON. Rotate the "LIGHT CONT." knob of "MEGALIGHT 100" to adjust brightness so that the image of pinhole can be checked by the collimator. Then turn the focus ring of the lens to adjust the shape.
- 5) Check the optical axis. If it is the case except Fig.1 ① of the previous page, loosen 3 screws (#63) and adjust the G1 lens in the direction shown in Fig.2 of the previous page.
- 6) When it becomes as shown in Fig. 1 ①, fix the G1 lens with 3 screws (#63).



4th Lens group alignment

Note: This adjustment is required when the 4th lens groups is removed.

(1) Preparation of Lens optical alignment equipment

- Fix the attachment holder for 4th lens group (J19127L) in the lens equipment for periphery alignment.
How to fix: Move down the holder-moving lever slowly so that the holder touches the stage. Then tighten 4 screws to fix it.

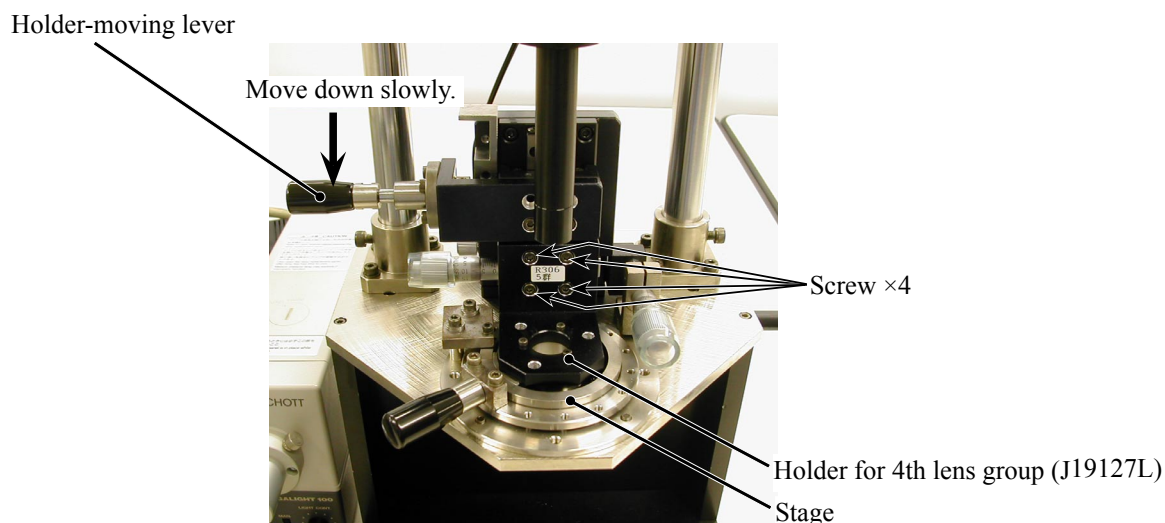

- Create the center positioning tool (ref. Page42-13 for how to create it).
- Create cardboards in which "Lens alignment chart" and "Viewers" are fit. (ref. Page 42-15 for how to create them.)
 - As for AF-S17-55/2.8G, the below equipment for center (left) is NOT used.

Lens optical alignment equipment for center (left) and periphery (right)

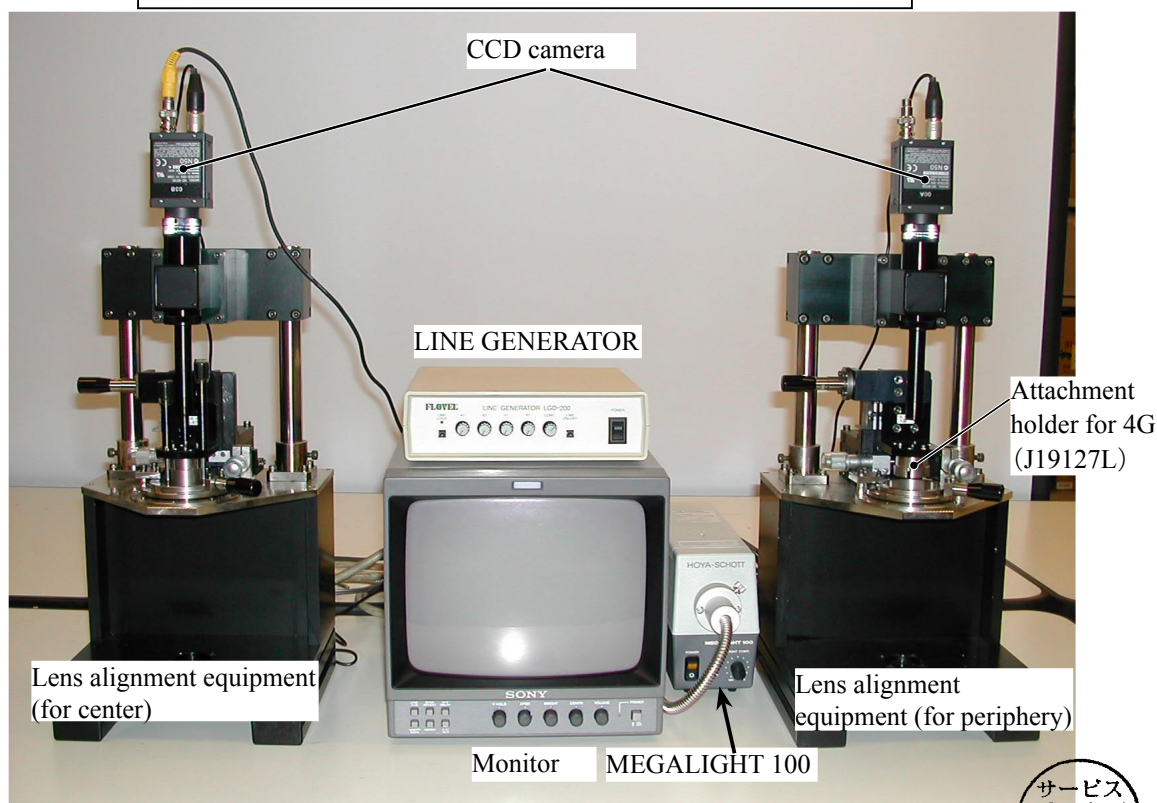

Back view of Lens optical alignment equipment for center and periphery

- Connect each cable to the appropriate equipment with the same number. (e.g. Connect up ① to ①)

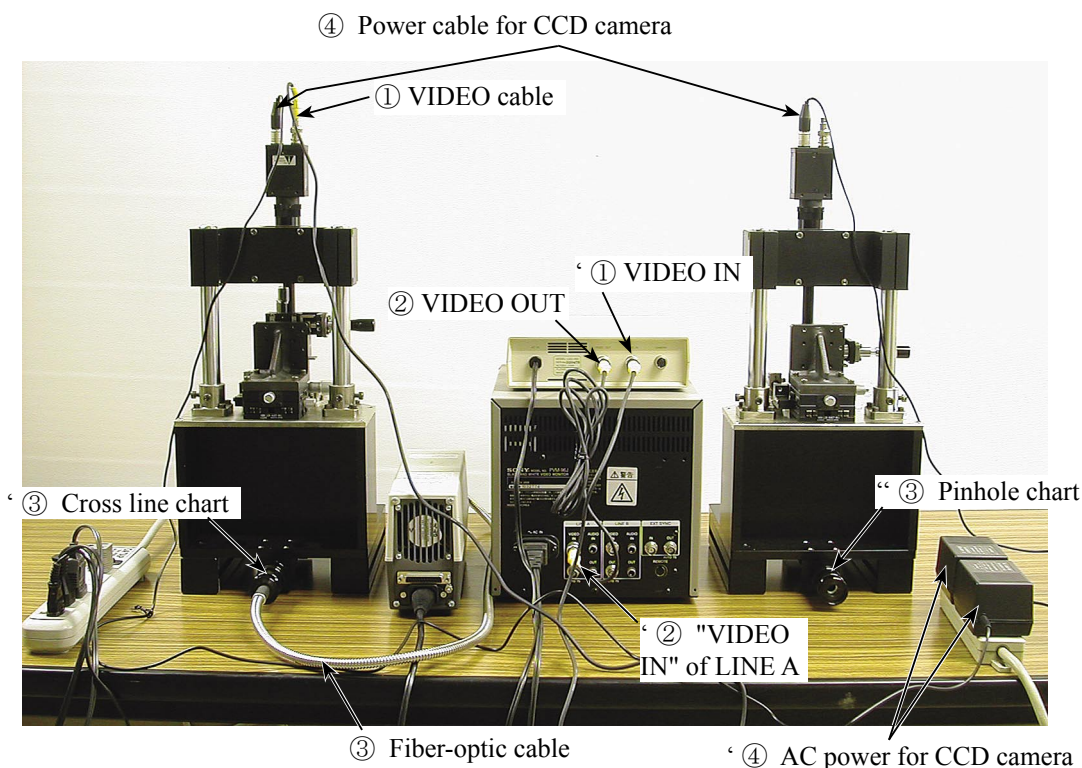
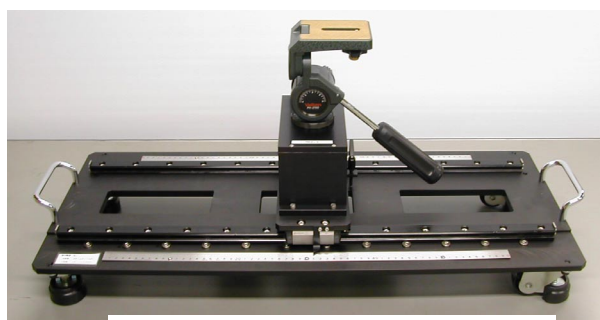
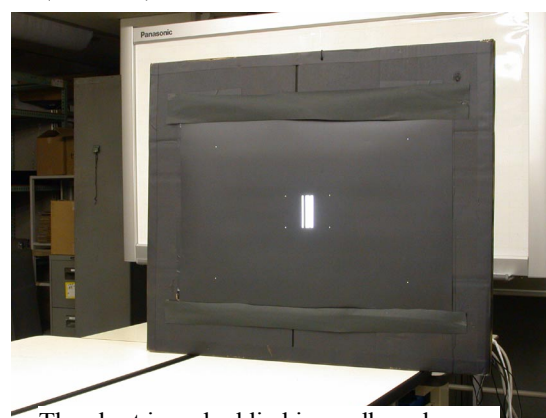

Chart shooting equipment for 5th lens group alignment

△ (Revision)



Slide rail for Lens alignment equipment



The chart is embedded in cardboards.

(2) Chart shooting for the 4th lens alignment

- ① Prepare a camera (D100). Set the shutter speed to “M1/100” and the focus mode to “S”. On the shooting menu, set the Image Quality mode to “RAW”, the WB to “Preset” and the ISO to “200”.
- ② Set up the camera (D100) on a tripod on the slide rail. Set the indication pointer of the tripod to 30 cm.

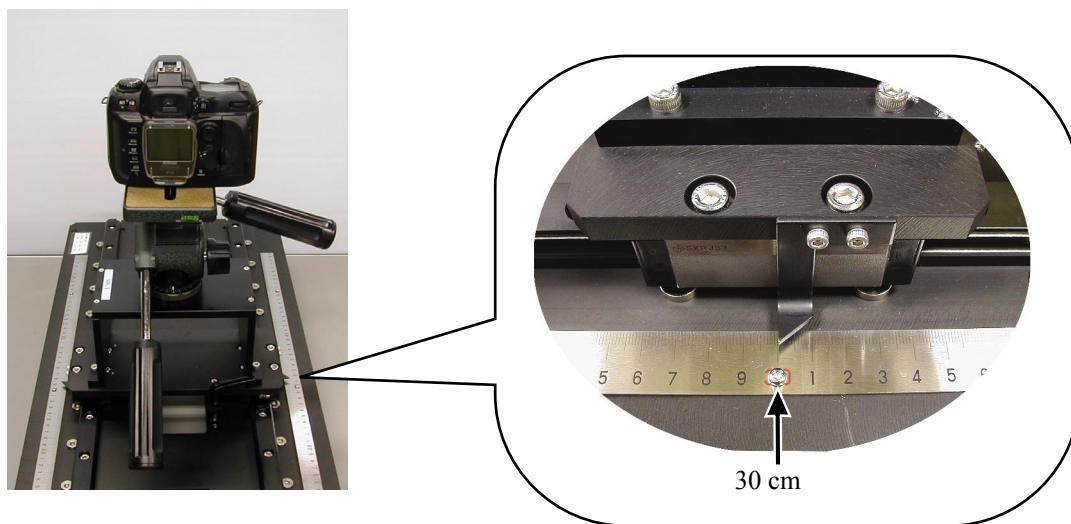

③ Set the alignment chart (J19128) as shown below.

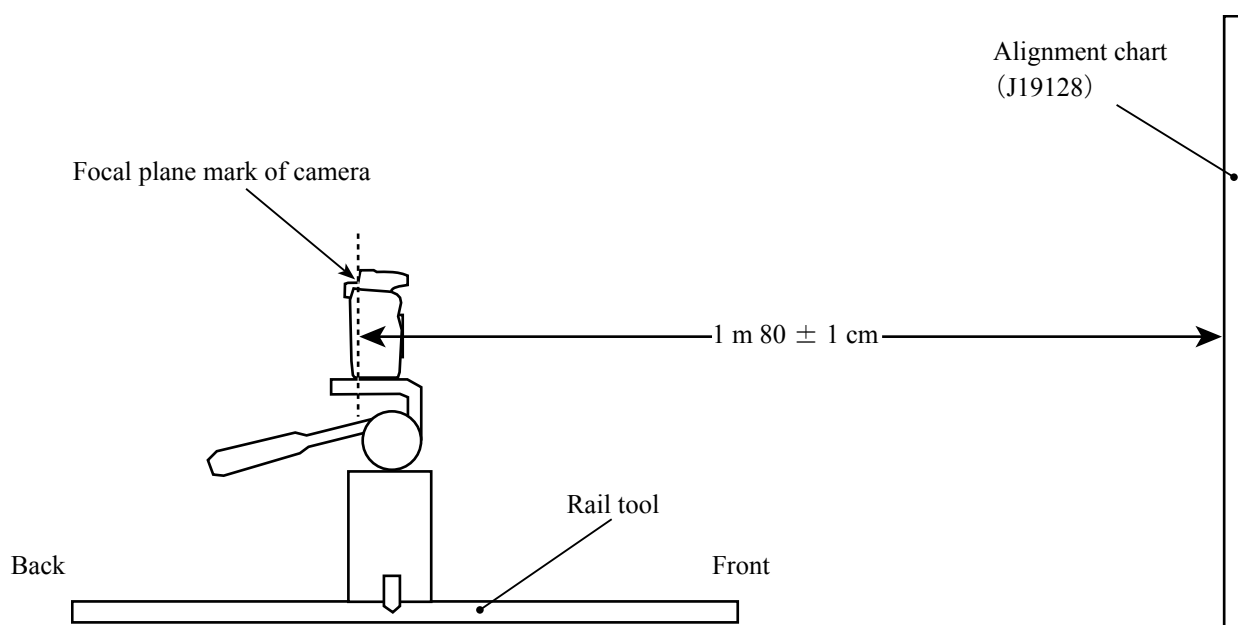

④ Turn the power of viewers (5 pcs.) to ON.

(Note: If the batteries of viewers are exhausted with decreased brightness, the shooting data cannot be obtained correctly.)

△ (Revision)

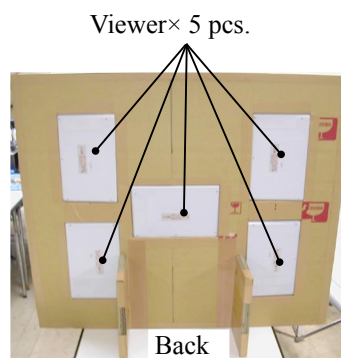
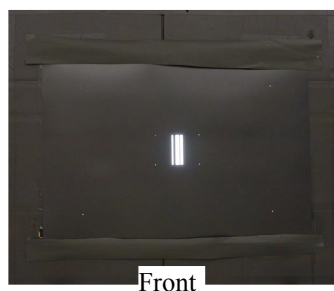

- ⑤ Fit the lens to be examined in the camera. Set the zoom to TELE (55mm).
- ⑥ By looking through the viewfinder, adjust the height and tilt to make the chart fill the entire finder field frame.
- ⑦ Adjust the tilt of the slide rail to make the 3 chart lines position in the center of the viewfinder, when the tripod is slid all the way to the front and back.



- ⑧ Connect the PC and camera via USB. (Camera setting: Mass Storage)
- ⑨ Start the adjustment software (LWM.exe).
 - △ (Addition)
- ⑩ "Lens select" window. Then select "AF-S 17-55/2.8G" and click "ok".
- ⑩ Click the "Reset all log" button.
- ⑪ Set the indication pointer of the tripod back to 30 cm. Clicking "Focusing" button activates the AF of camera.

△ (Revision)

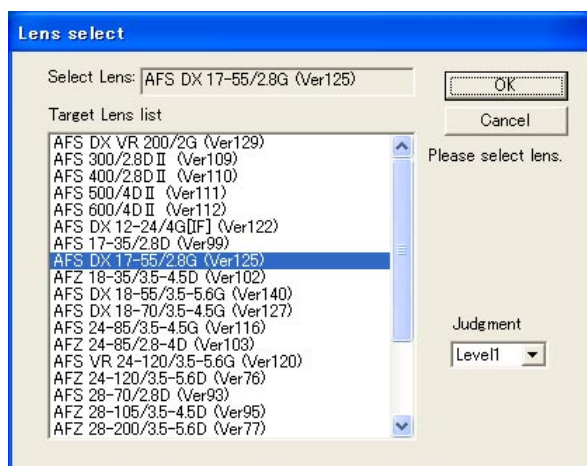

△ (Revision)

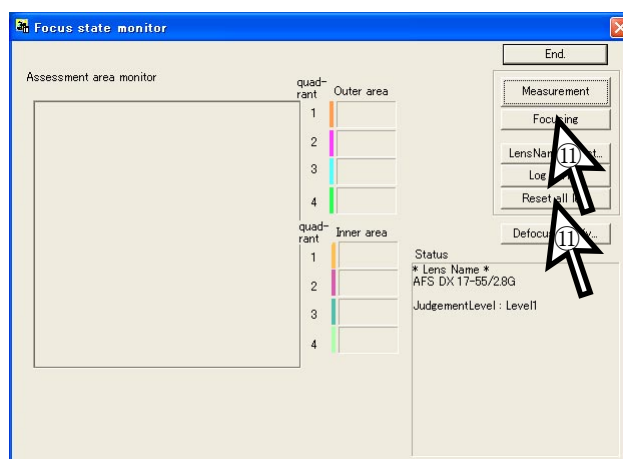

- ⑫ Set "Focus mode" of camera (D100) to "M".
- ⑬ Slide the tripod to the front by 18 ± 0.1 cm.
- ⑭ Click the "measurement" button of the adjustment software.

△ (Revision)

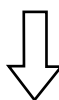
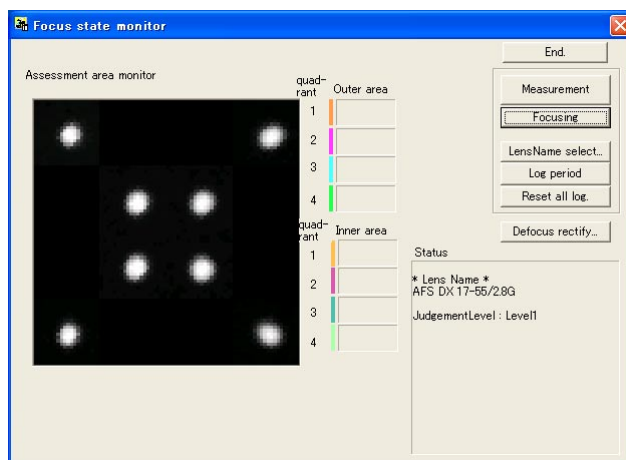

△ (Revision)

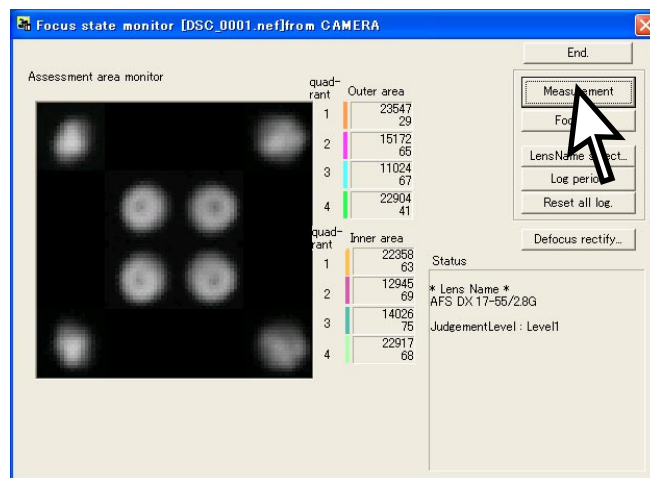

- ⑮ When the shutter of the camera is released, slide the tripod to the back by 6 ± 0.1 cm and make a remeasurement.
- ⑯ Again, slide the tripod to the back by 6 ± 0.1 cm and make a remeasurement.
- Repeat this operation 4 more times, totalling in 7 measurements. (The total sliding distance is 36 cm.)

Note 1: When the below warning is given, there may be some defects in the brightness of the viewers and/or parallelism of the chart and camera, etc. So correct the above and make a remeasurement.

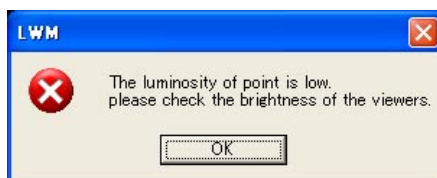

Note 2: When the below warning is given, recheck that the Quality mode of the camera is set to RAW.



Note 3: When the below warning is given, recheck that the zoom ring of the lens is set to TELE-end.



- ⑰ After the 7 measurements, point the cursor to the confirmation screen of the software. Click it 3 times, and if "END" is displayed on the Information, the lens optical alignment is completed. If "END" is NOT displayed (e.g. : X directions:+1, Y directions:-1), go to the next "(3) 4th lens group alignment (periphery alignment)". In case "Need Adjustment" is indicated when "END" is NOT displayed, make readjustment starting from the previous "1st lens group alignment (for center alignment)".

△ (Revision)

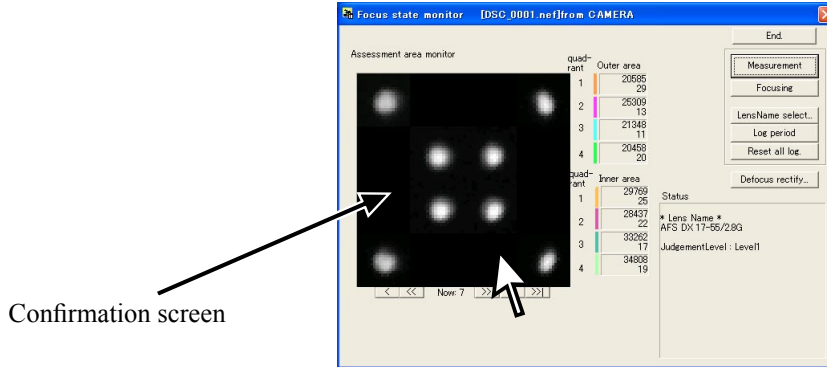

△ (Revision)

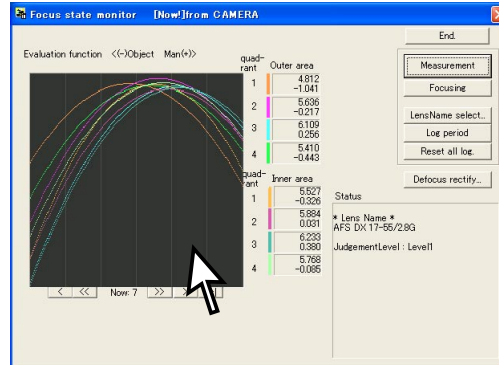

△ (Revision)

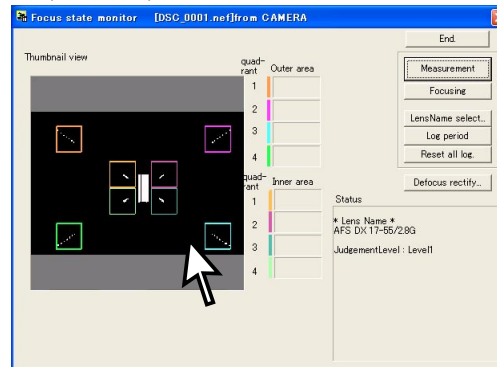

△ (Revision)

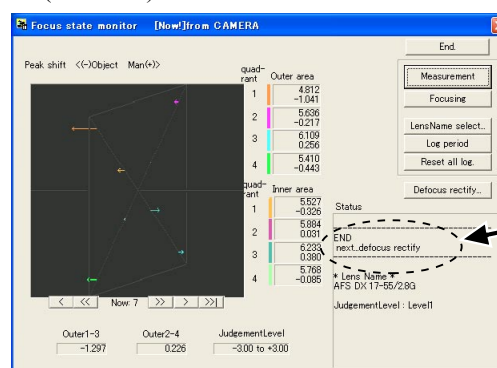

(3) 4th lens group alignment (periphery alignment)

- ① Mount the (self-made) center positioning tool on the lens alignment equipment (for periphery) with the groove positioned slightly toward the counterclockwise direction from the below 12 o'clock position. Then turn the tool clockwise all the way to the right, and move the lever to the left to fix it.

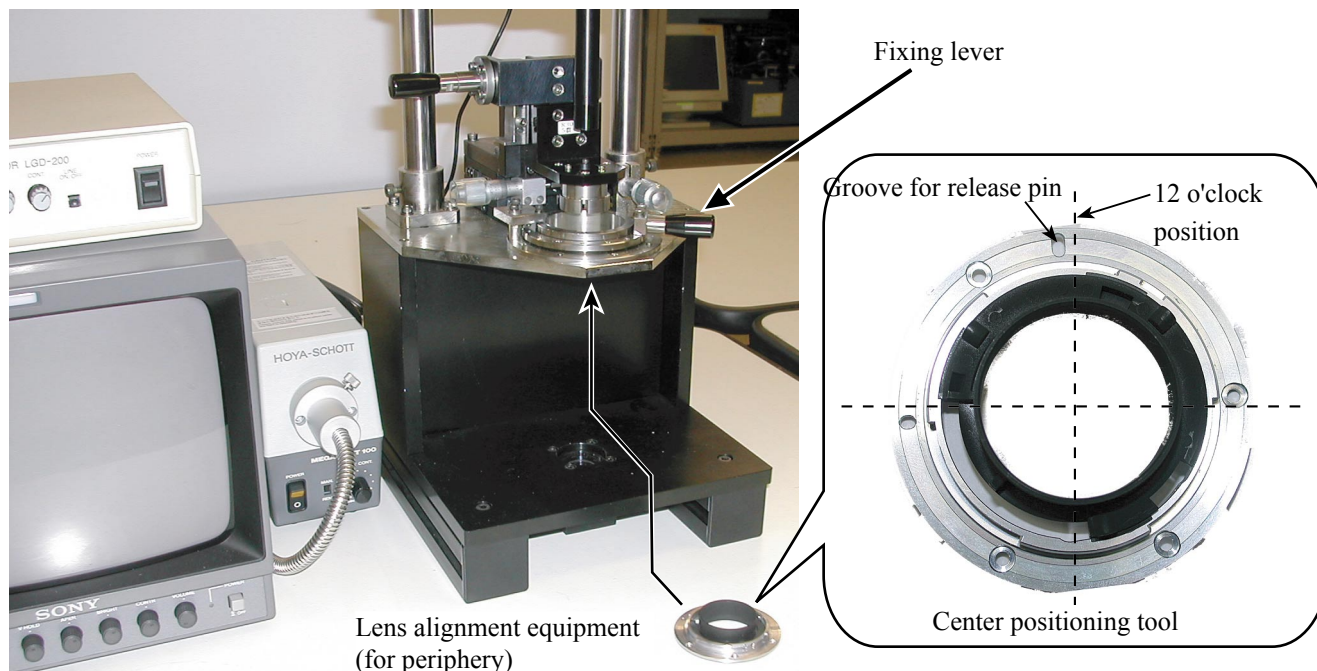

- ② Unlock the holder-moving lever, and move the holder down slowly by the lever.

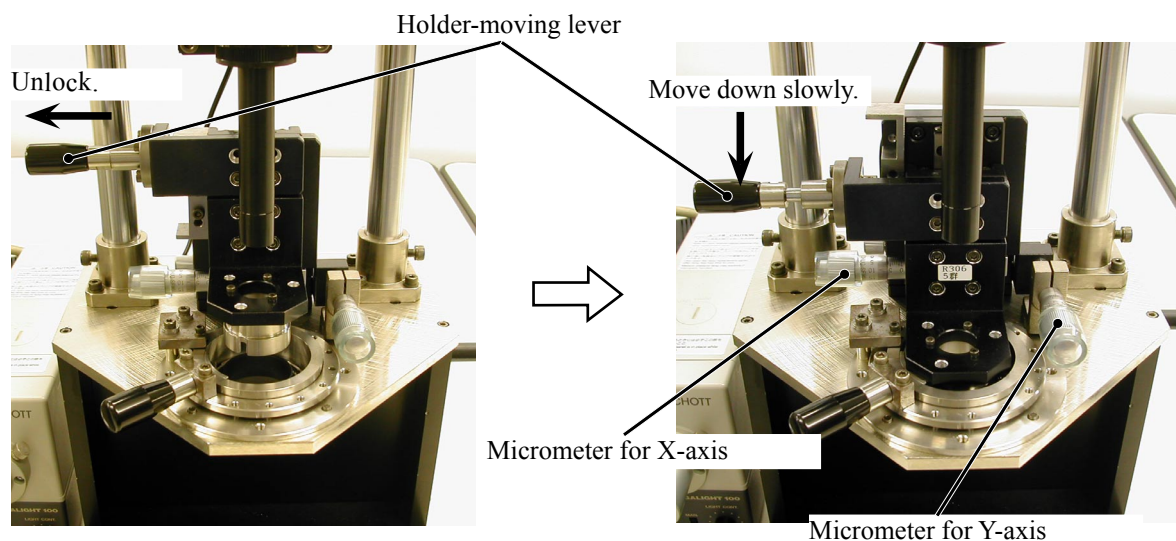

- ③ Adjust the holder's position by rotating the micrometers for X-axis or Y-axis so that the holder does not touch the protection ring of the center positioning tool.

Note) Without this alignment, the 4th lens may be damaged by the holder.

- ④ Move the fixing lever of the alignment equipment to the right, and remove the center positioning tool from the equipment.



- ⑤ Insert 3 alignment screwdrivers (long, middle, short) in the 4th lens group holder, and move the holder-moving lever up to lock the holder.

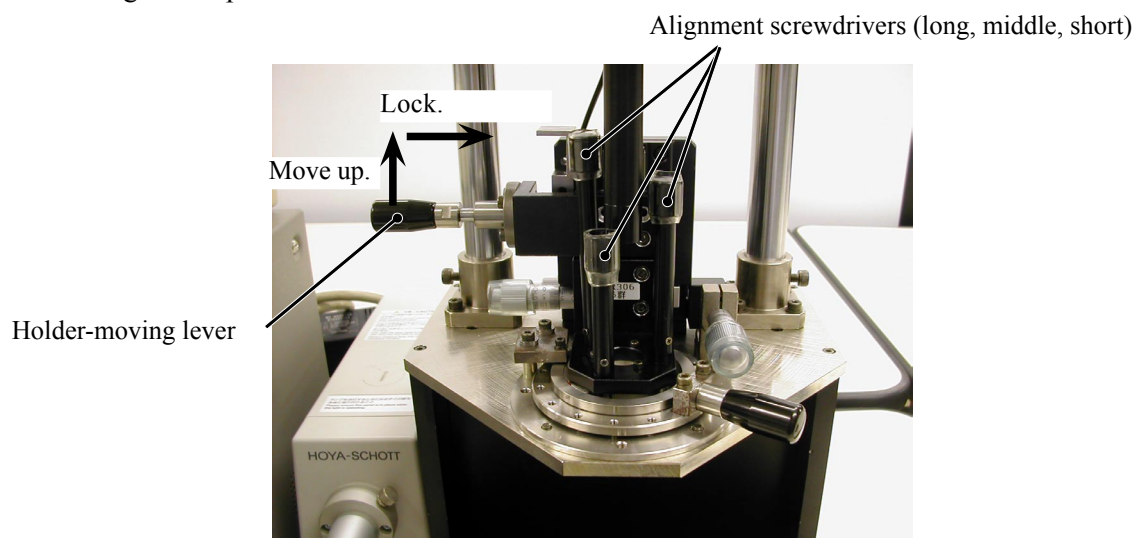

- ⑥ Mount the lens to be examined on the equipment (for center alignment) and set to WIDE-end. (ref. ① for how to mount it.)

- ⑦ Turn each power of the Monitor, LINE GENERATOR, and MEGALIGHT 100 to ON. Adjust the cross lines on the monitor by turning the "LIGHT CONT." knob of "MEGALIGHT 100" and the focus ring until the calibration of the cross lines can be seen clearly.

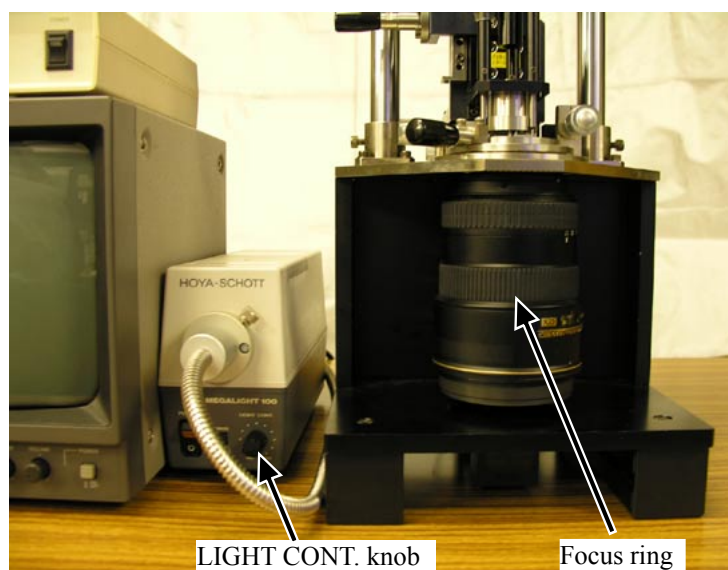
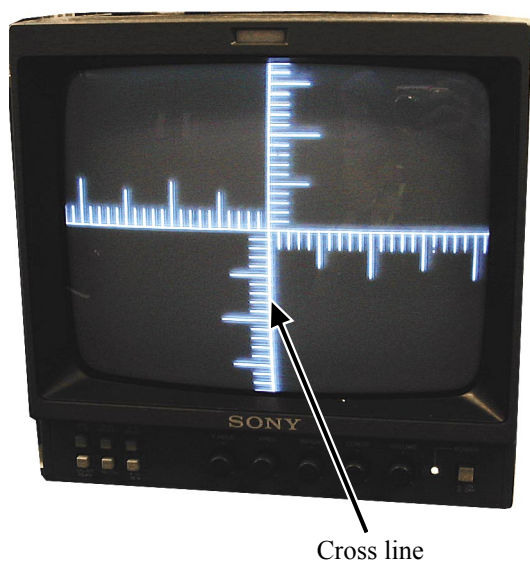

Note) In case the cross lines are tilted, adjust them by turning the chart, which is screwed in the rear tube of the equipment. (Just slight slackness of the chart poses no problems.)



- ⑧ Press the "LINE ON/OFF" button of LINE GENERATOR. Turn the knobs of "X1" and "Y1" so that X- and Y-lines are displayed on the monitor.

Superpose these X- and Y-lines on the cross lines of the CCD camera. Then press "LINE LOCK" button to fix these X- and Y-lines.

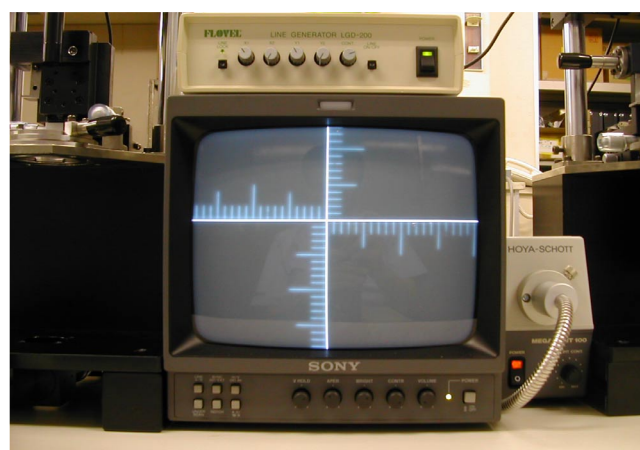
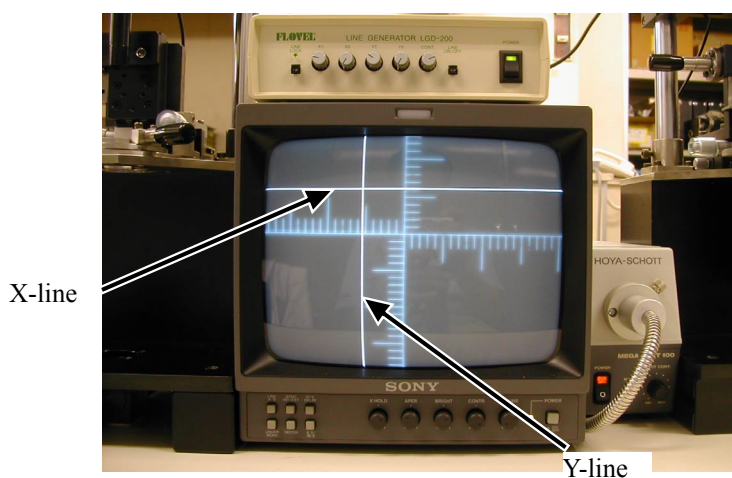
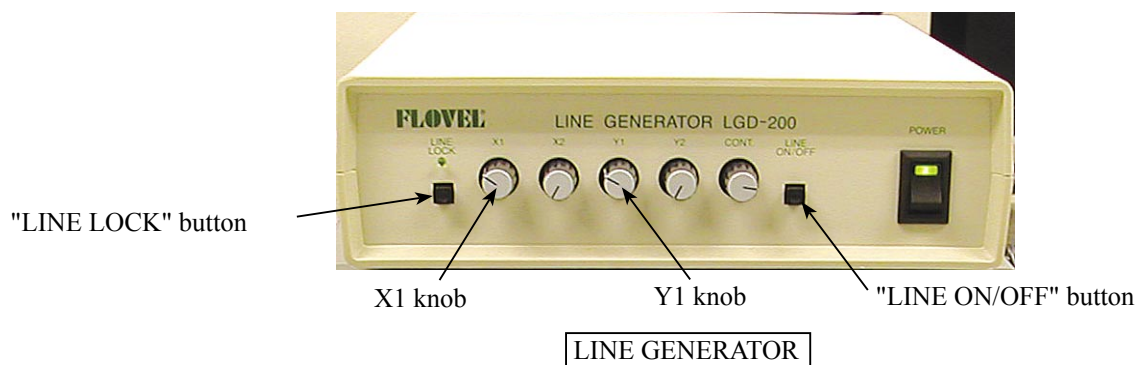

- ⑨ Unlock the holder-moving lever and move the holder down slowly by the lever. Insert the alignment screwdrivers (long, middle, short) into the screw holes of the 4th lens chamber.

Note) Because the screws cannot be seen, when inserting the alignment screwdrivers, put them straight down in the screw holes so that the screws can be easily found.

- ⑩ Rotate the micrometers (X and Y), and shift the cross lines by the scales that were results of the chart shooting of the 4th lens group alignment.

(e.g. Refer to "Pic.2" for the case of <X directions:+1, Y directions:-1>)

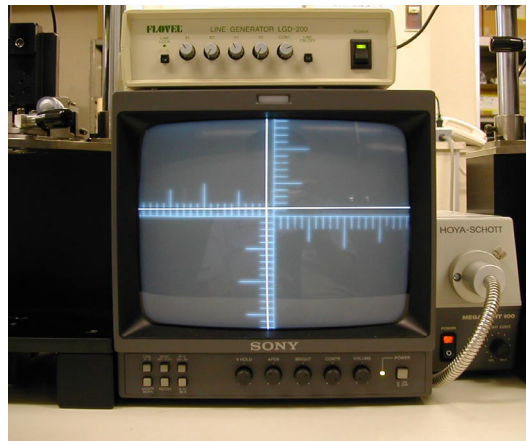

Pic.1

- ⑪ Fix the 3 screws of the 4th lens chamber with the alignment screwdrivers. Move the holder-moving lever up to lock the holder.
- ⑫ Check that a shift length caused by the cross lines and the X/Y lines is equal to the scales (1 = 1 scale of the calibrated cross lines) of the results of "Chart shooting of the 4th lens group alignment". (ref. Pic.1)

Note: After fixing the 3 screws of the 4th lens chamber, if a shift length is different from the results of the chart shooting, repeat the procedure from ⑨ to ⑫ until they become equal.

- ⑬ Turn each power of the Monitor, LINE GENERATOR, and MEGALIGHT 100 to OFF. Remove the lens from the equipment (for periphery).

Then go back to "(2) Chart shooting of the 4th lens group alignment" and repeat the procedure (2) and (3) until the result becomes "END".



[How to create positioning tool of 4th-lens-group holder for lens alignment (AF-S DX ED 17-55/2.8G)]

It is the same tool with AF-S ED 24-85/3.5-4.5G

1: Summary

1-1: This is a positioning tool of the 4th lens group holder for lens alignment, in order to secure the position for attaching the 4th lens group temporarily.

2: Preparation

2-1: The following is used:

- * Rear cover ring (JAA78071- Part no. :1K631-287) X 1 pc.
- * Bayonet mount (JAA78071- Part no.: 1K404-157) X 1 pc.
- * Mount rotation stopper screw (JAA78071- Part no.: 1K120-012) X 1 pc.

3. Procedure

3-1: Put the bayonet mount as shown in Fig. 1.

Put with the groove, in which the lock pin of camera body enters, just upward.



Fig. 1

3-2: Mount the reversed rear cover ring on the position of Fig. 1, and attach them as shown in Fig. 2.

Put with the groove, in which the lock pin of camera body enters, just upward.



Large notch of rear cover ring.

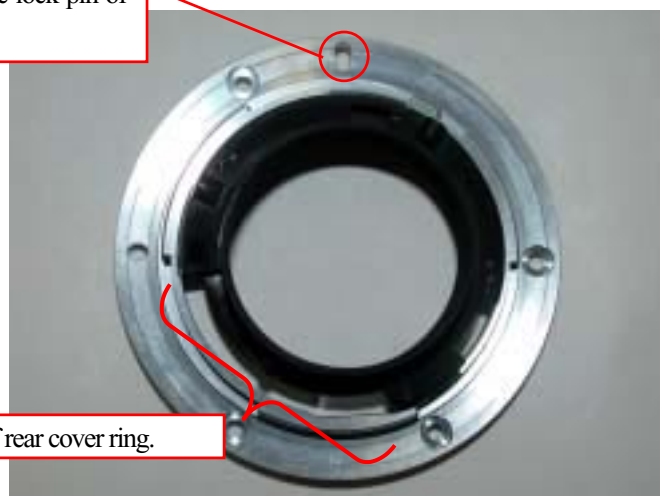

Fig. 2



3-3: Turn the rear cover ring clockwise, which was attached to the bayonet mount. Then stop at the position as shown in Fig.3-1.

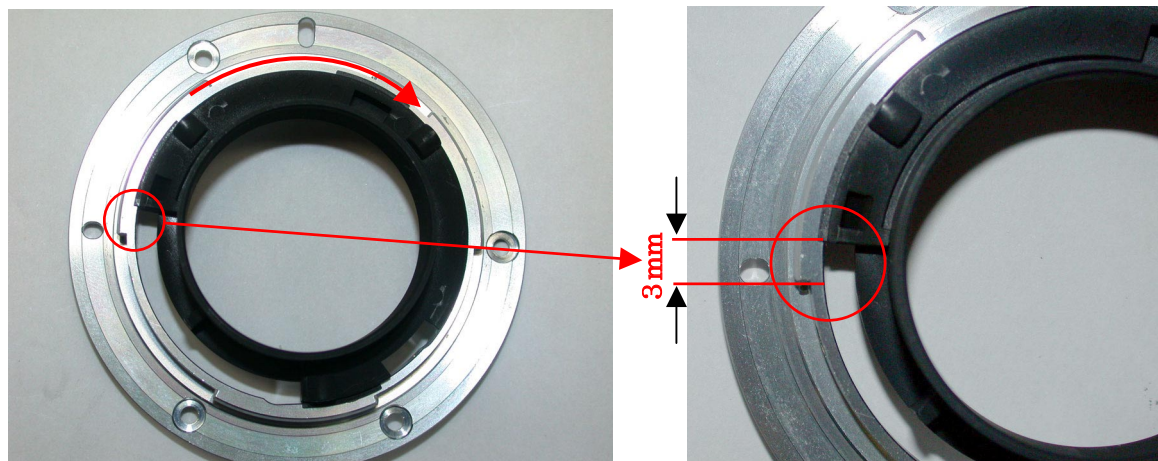

Fig. 3

Fig. 3-1

3-4: Fix the following 3 locations of the rear cover ring with the instant adhesive.

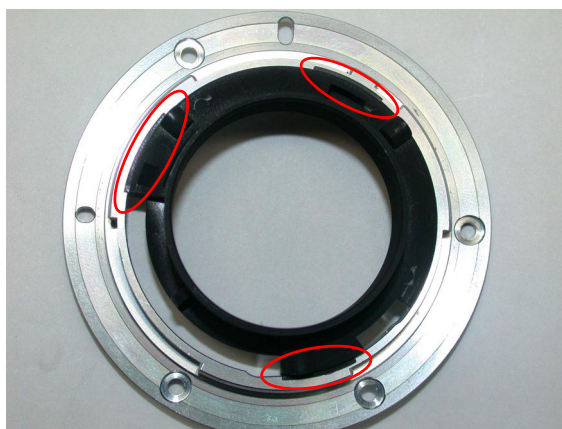
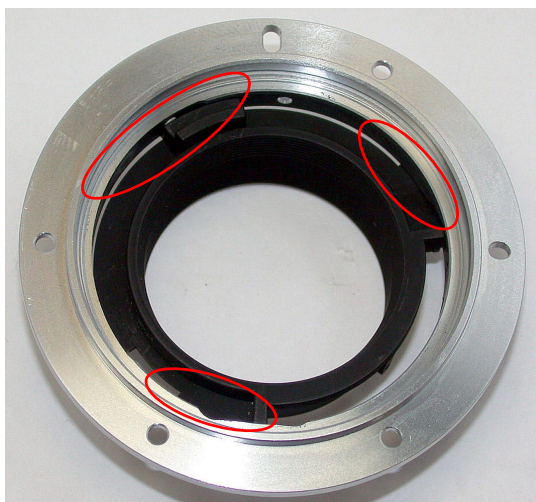

Fig. 4

3-5: Turn the bayonet mount over. Reinforce the following 3 locations with the adhesive to attach the bayonet mount and rear cover ring firmly.



3-6: Attach the mount rotation stopper screw at the appropriate position.



How to create Setting board of "Lens alignment chart" and "Viewer"

1. Summary

1-1: In order to get necessary data for lens alignment, this board is created to use for setting a special chart and light viewers (for chart illumination), while taking pictures of the special chart with a digital camera.

2. Preparation

2-1: Prepare a board (760 x 880 x 20 mm) or 2 package cardboard boxes (size 2.33).

(Note) Because you have to cut out the shape to embed light viewers, choose package cardboard boxes (size 2.33) or material which can be easily cut. — ref. Fig. 1

3. Procedure (In this document, 2 package cardboards are used)

3-1: As for the 1st flattened cardboard box (size 2.33), check the positions for embedding the light viewers, and cut out the shape at 5 locations (shaded parts/size 154 x 245 mm) as shown below. — ref. Fig. 2

(Note) Cutting the shape slightly smaller than the actual size of viewers makes it easier to fit the positions of viewers tightly.

3-2: Put the 2nd flattened cardboard box (size 2.33) and the above cut-out 1st cardboard together as one, and fix them by taping at 4 sides. — ref. Fig. 3

3-3: Then as for the 2nd flattened cardboard box, cut out the shape again by matching the cut-out size of 3-1 for each viewer. — ref. Fig. 4

3-4: Reinforce the edges of cut-out parts with tape.

(Note) To prevent viewers falling off, secure them with tape around the edges. — ref. Fig. 5

3.5: Blacken around the setting board (with black spray, etc).

△ (Addition)

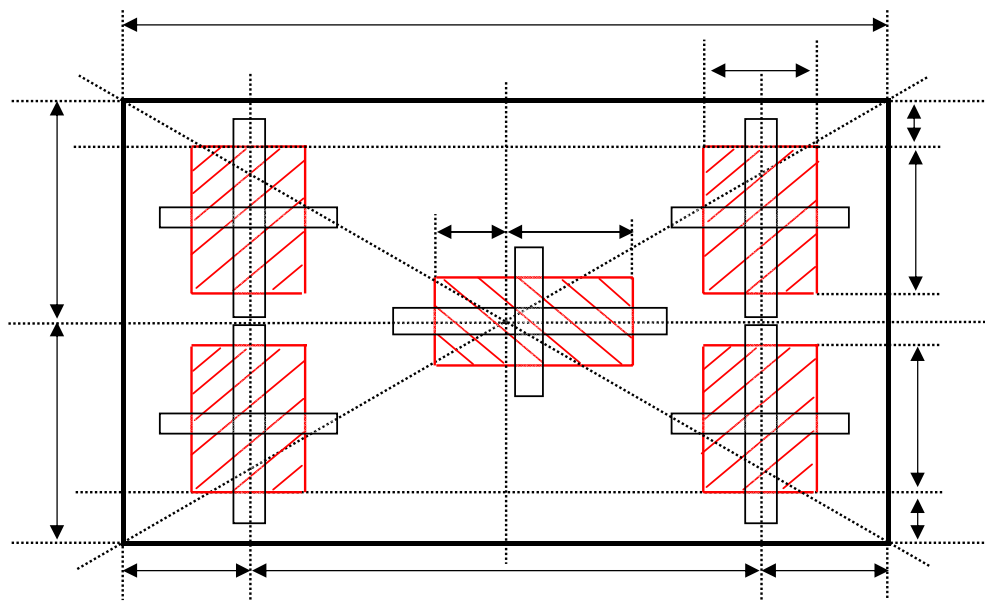

4. Prevent Viewers from falling off (In this document, 2-mm width Velcro tape is used.)

4-1: As shown above, when viewers are embedded, secure them with square pieces of Velcro tape (hook and loop fastener) on the back of the cardboard to prevent viewers falling off.

(Fig. 1- Prepare 2 package cardboard boxes, and flatten them as below.)



(Fig. 2 - As for the 1st flattened cardboard box, cut out the <154 x 245 mm sized> shape at 5 locations.)

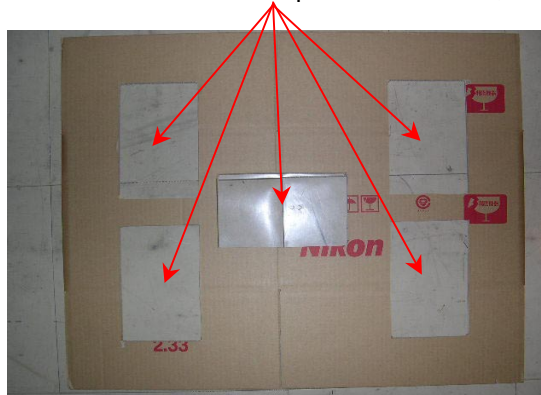

(Fig. 3- Package cardboard boxes)
Put the 2nd flattened cardboard box and the 1st cut-out cardboard together as one as shown below.

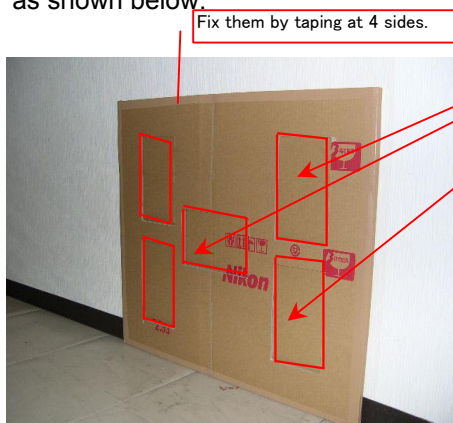

Fix them by taping at 4 sides.

(Fig. 4- As for the 2nd flattened cardboard box, cut out the shape in the same way as Fig.2. All cardboards are cut out as below.)

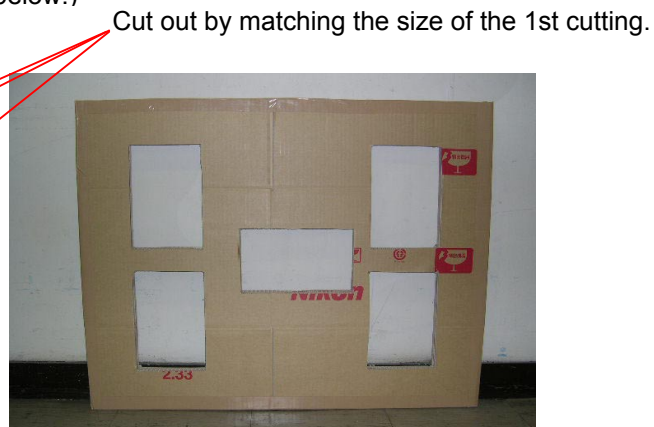

Cut out by matching the size of the 1st cutting.

(Fig. 5- Light viewers are embedded.)

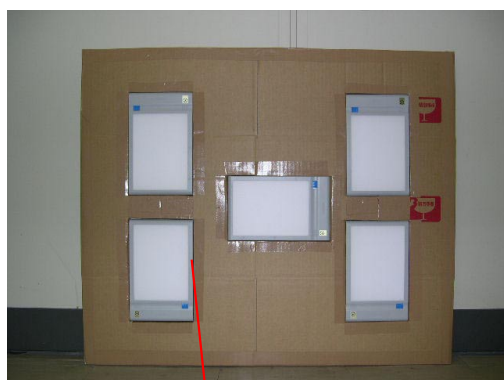

To prevent viewers falling off, secure the viewers with tape around the edges.

△ (Revision)
(Fig. 6 - cartoon box is blackened with the chart being attached.)

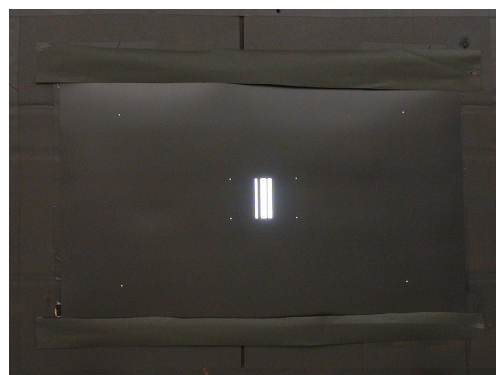

FILTER RING

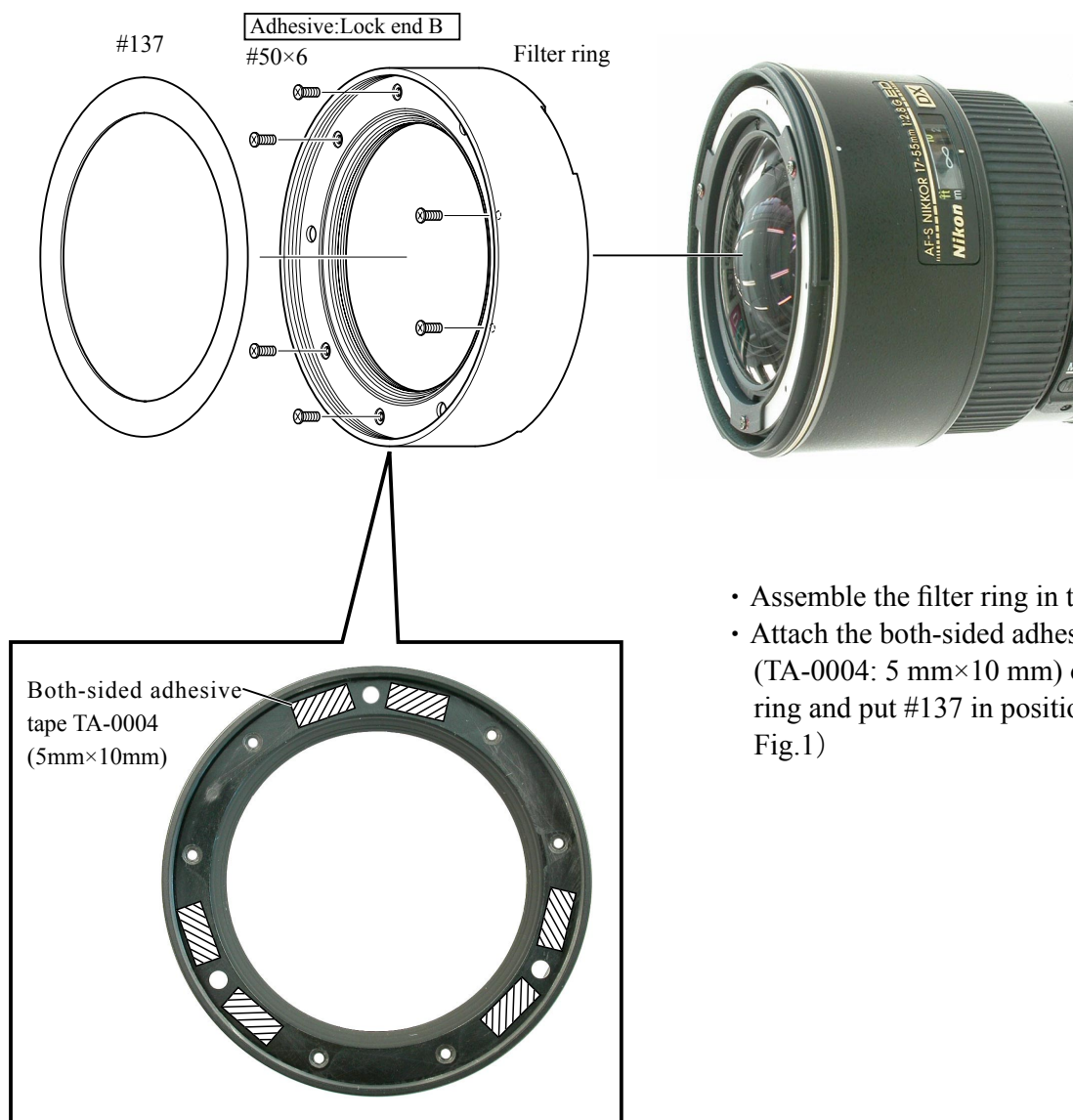

- Assemble the filter ring in the body.
- Attach the both-sided adhesive tape (TA-0004: 5 mm×10 mm) on the filter ring and put #137 in position. (ref. Fig.1)

Fig.1

PREPARATION FOR INSPECTION / ADJUSTMENT OF MAIN PCB

- In case of replacing the main PCB, SWM unit or MR encoder unit, be sure to make the necessary adjustments as follows:

1. Adjustments

- Adjust the MR duty
- Adjust the driving frequency and motor control

2. Equipment and tools to be required

- Single output rated voltage power supply: 1 unit (6.0V 3.0A)
- Oscilloscope: 1 unit For adjusting the MR duty, the driving frequency and motor control
- AF-I communication box (J15306-1): 1 unit
- AF-I communication adapter (J15307): 1 unit

【System configuration】

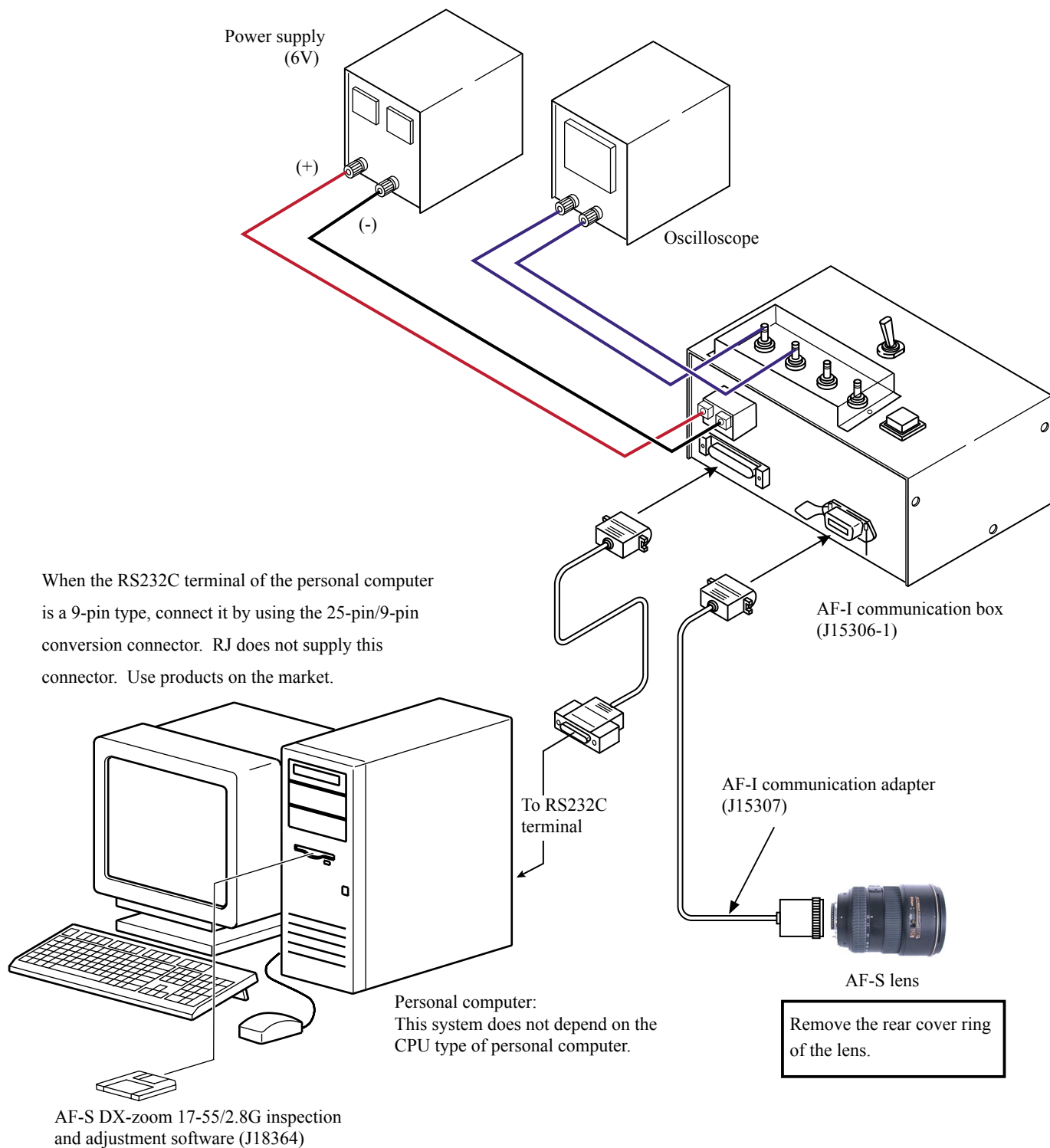

ADJUSTMENT OF MR DUTY

- In case of replacing the main PCB, SWM unit and MR encoder unit, be sure to make adjustments.
- In case of replacing the main PCB, be sure to perform [READING AND REWRITING OF EEPROM DATA.] then [3.WRITING THE FIXED VALUES.]

How to adjust

- ① Make sure that the electric current and voltage of the connected rated voltage power supply are set to the set values. Then, turn the rated voltage power supply ON for the contacts A and F.
- ② Select "MR DUTY ADJUSTMENT" in the menu of the AF-S DX-zoom 17-55 inspection program.
- ③ The display for checking whether the fixed values are written in EEPROM appears. Select a proper item.
- ④ According to the instructions on the screen, rotate the MF ring from the near distance to the infinity to the near distance direction slowly by hand. Make sure that the waveform on the oscilloscope has duty 50% and then stop the MF ring at the near distance end.

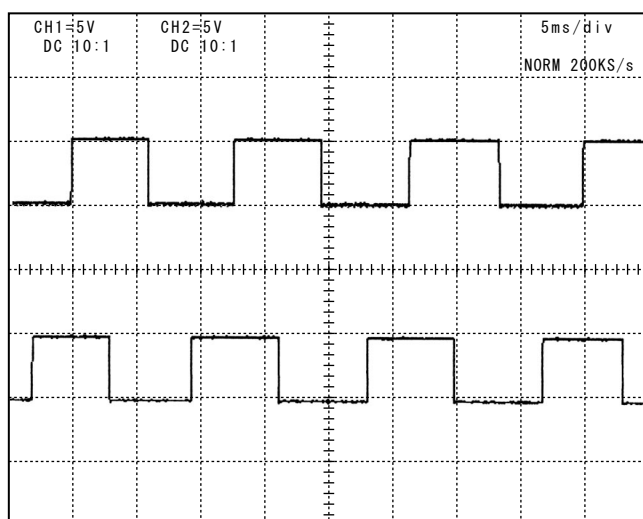

● Setting of oscilloscope

V/Div (CH1)	: 5V
V/Div (CH2)	: 5V
Coupling	: DC
Time/Div	: 5 m Sec
Trigger Mode	: NORMAL
Trigger Coupling	: DC
Trigger Source	: CH 1
Trigger Position	: +4 div
Trigger Type	: EDGE
Trigger Level	: 2.5 V

- ⑤ According to the instructions on the screen, rotate the MF ring from the near distance to the infinity direction slowly by hand. Make sure that the waveform on the oscilloscope has duty 50% and then stop the MF ring at the infinity end.

Note : In case the waveform from infinity to close distance position or vice versa does not have duty 50%, repeat "INSPECTION AND ADJUSTMENT OF THE MR ENCODER OUTPUT WAVEFORM" on Page L20.

Standard $H : L = 100 : 200 \sim 200 : 100$ (50% \pm 17.3%)

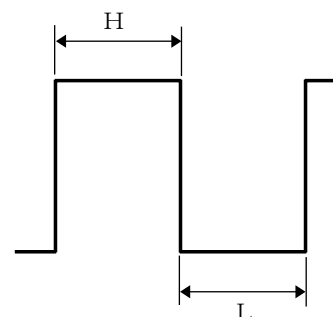

ADJUSTMENT OF DRIVING FREQUENCY AND MOTOR CONTROL

● In case of replacing the main PCB, SWM unit or MR encoder unit, be sure to make adjustments.

- ① The connection of the rated voltage power supply and measuring tools is the same as "ADJUSTMENT OF MR DUTY". Turn on the rated voltage power supply.
- ② Make sure that the current and voltage of the rated voltage power supply are the set values.
- ③ Turn on the rated voltage power supply.
- ④ Select "ADJUSTMENT FOR DRIVING FREQUENCY & MOTOR CONTROL" in the menu items of the AF-S DX-zoom 17-55/2.8G inspection program. The lens starts scanning automatically.

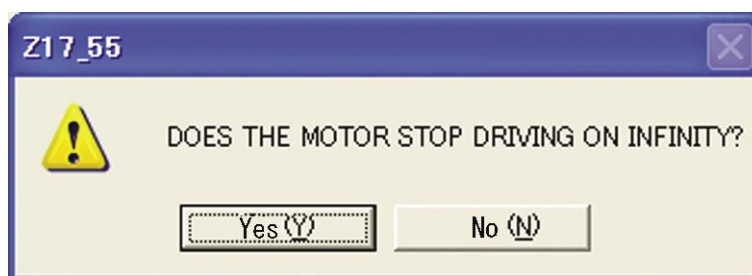

- ⑤ When the above display appears and the motor stops driving, select to end the adjustment.
If the motor does not stop driving, select to make the adjustments again.
If the adjustment is done again but the motor does not stop driving, adjust the MR duty again and then perform "ADJUSTMENT FOR DRIVING FREQUENCY & MOTOR CONTROL" again.
If the adjustment is not successful yet, the SWM unit or cam ring unit may be defective.

INSPECTION OF LENS OPERATIONS

Check the lens operations by using a personal computer after assembling.

○ Check by using a personal computer

● Check items

1. Operation of MR encoder

- Drive the scanning of lens and check the difference in pulses between start end.
- In case the MR head of the MR encoder is malpositioned on the magnetic tape, the difference in pulses gets large.

2. Lens-servo stop accuracy

- Check the number of overrun/underrun pulses (deviation of the stop position from the target position) per the specified lens driving.
- In case the irregularity of mechanical operations does not take place in the focus ring driving unit, the underrun tends to occur if it is heavy in the cam ring rotation of the MR encoder, while the overrun tends to occur if it is light in its rotation of the MR encoder.

3. Lens-servo time

- Check the servo time (from starting and stopping the servo) when driving the specified lens by using the oscilloscope.
- In case the irregularity of mechanical operations does not take place in the focus ring driving unit, the servo-time tends to be long if it is heavy in the cam ring rotation of the MR encoder, while the servo-time tends to be short if it is light in its rotation of the MR encoder.

4. Check of switches and lenses

- Check the ON/OFF operations of switches, the distance encoder and zoom encoder.

● How to treat after inspection

1. When the MR encoder operation is out of the standard:

Adjust the MR duty again. (ref. Page L46.)

If the pulse is out of standard, adjust the output pulse/waveform from the MR encoder again. (ref. Page L20.)

If the pulse meets the standard, replace the cam ring unit.

2. When the lens-servo stop accuracy is out of the standard:

Check the output pulse/waveform from the MR encoder. If it is normal, replace the cam ring unit.

3. When the lens-servo time is out of the standard:

Adjust the driving frequency and motor control again.

If the lens-servo time is still out of the standard after the readjustment, replace the cam ring unit.

4. When switches do not operate properly:

Check the wiring pattern of such troubled switch or replace it.

●AF-S zoom DX17-55/2.8G inspection program

(1) Menu display

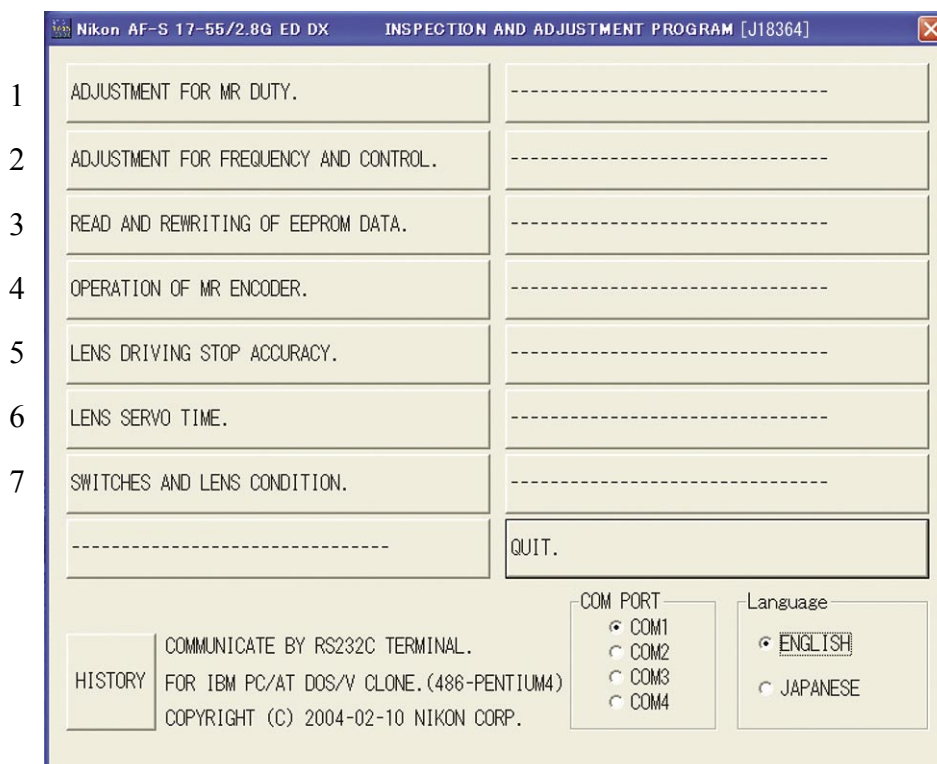

• Menu items

The items 1 and 2 are used for adjustments.

The item 3 is used for reading and writing EEPROM DATA.

The items 4~7 are used for inspections.

• Selection items

After selecting any item, one of the lens selection display, the focal length selection display, the voltage setting, display, the inspection start display, etc. appears. The displays are different depending on the items. Follow the instructions of a personal computer.

• Operating voltage

	Power supply for AF motor inside lens	Power supply for AF-I communication box
Inspection of MR encoder operation	6.0 ± 0.1 V	5.5± 0.2 V
Inspection of lens-servo stop accuracy	6.5 ± 0.1 V	
Inspection of lens-servo time	6.5± 0.1 V	
Inspection of switches and lenses	6.0 ± 0.1V	

• Initial driving

When "WAIT FOR SOME SECONDS" appears, perform the initial driving (drive scanning five times and stop at infinity-end).

(2) Inspection of MR encoder operations

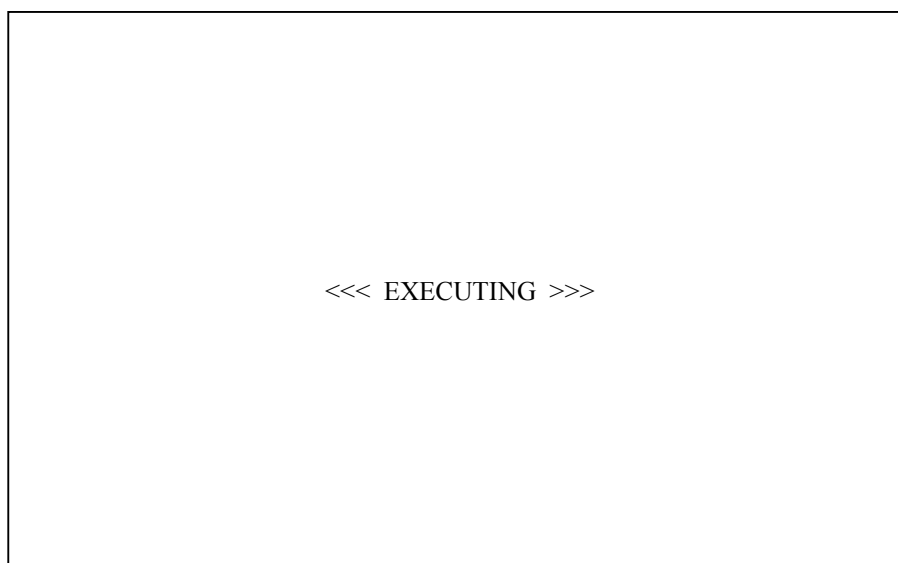

Caution : If the MF ring is rotated during lens scanning, error value is shown the pulses.

Do NOT touch the MF ring during operations.

Execute inspection for the 5 positions as below.

(Lens position in inspecting)

Lens inclination	Position of index window
Horizontal	Up, right and left
Front lens group 90° upward	
Front lens group 90° downward	

When the inspection is ended, the inspection result appears in the next page.

The total number of pulses when inspecting must be within the standard.

Standard of the total pulses : 4044 ± 125 PLUSE(S)

TYPE OF LENS : AF-S 17-55mm/2.8G DX CPU VERSION : 2.01.00

THE TOTAL NUMBER OF PULSE(S) AT INSPECTION. [PULSE(S)] ---- 4044

STANDARD FOR THE TOTAL PULSE NUMBER : FROM 3919 TO 4169 [PULSE(S)]

IN STANDARD.

PUSH OK TO RETURN TO MENU.

OK

(3) Inspection of lens-servo stop accuracy

```

INSPECTION OF DRIVING STOP ACCURACY.
NUMBER OF LENS GO-AND-RETURN OPERATIONS.          : 5 / 5 TIME(S).
LENS DRIVING TIMES. (DF0+DF1+DF2+DF3+DF4+DF5+DF6) : 85 TIME(S).
MAXIMUM PULSE. (ABSOLUTE) (DF0+DF1+DF2+DF3+DF4+DF5+DF6) : 3 PULSE(S).
OVER ( OR UNDER ) RUN PULSE(S).                  : - 1 PULSE(S).
LENS DRIVING TIMES : DF1=30 DF2=30 DF3=30 DF4=30 DF5=30 DF6=20
DIRECTION           : INF - > CLOSE          CLOSE - > INF
AMOUNT              : DF1      DF2      DF3      DF4      DF5      DF6
UNDER (-), OVER (+) : (-) (+) (-) (+) (-) (+) (-) (+) (-) (+) (-) (+)
0 - 5               : 0 10  0 10  2  8    3  2  5  0  5  0
6 - 15              : 0  0  0  0  0  0    0  0  0  0  0  0
10 - 15             : 0  0  0  0  0  0    0  0  0  0  0  0
16 -                : 0  0  0  0  0  0    0  0  0  0  0  0
DIRECTION           : INF - > CLOSE          CLOSE - > INF
AMOUNT              : DF4      DF5      DF6      DF4      DF5      DF6
UNDER (-), OVER (+) : (-) (+) (-) (+) (-) (+) (-) (+) (-) (+) (-) (+)
0 - 5               : 0 10  0  5  0  5    5  0  5  0  0  0
6 - 15              : 0  0  0  0  0  0    0  0  0  0  0  0
10 - 15             : 0  0  0  0  0  0    0  0  0  0  0  0
16 -                : 0  0  0  0  0  0    0  0  0  0  0  0
RATIO (1)           (%) : Df1=0.00 Df2=0.00 Df3=0.00 Df4=0.00 Df5=0.00 Df6=0.00
RATIO (2)           (%) : Df1=0.00 Df2=0.00 Df3=0.00 Df4=0.00 Df5=0.00 Df6=0.00
PUSH CANCEL TO RETURN TO FOCAL DISTANCE SET-UP MENU.
    
```

CANCEL

Caution : If the MF ring is rotated while the lens scanning is driven, the pulse shows an abnormal value. Do NOT touch the MF ring during operations.

During the lens driving, the above screen is displayed. Make inspections at the 5 positions as below.

(Lens position in inspecting)

Lens inclination	Position of index window
Horizontal	Up, right and left
Front lens group 90° upward	
Front lens group 90° downward	

The number of overrun/underrun pulses must be within the standards after the 5 lens back-and forth driving motions ("5/5TIME (S)." in [1] of the display).

Standard RATIO (1) is 40% or less for Df1~Df6. ② of the screen
 (Occurrence ratio of 6~15 pulses)

RATIO (2) is 10% or less for Df1~Df6. ③ of the screen
 (Occurrence ratio of 10~15 pulses)

Occurrence of 16 or more pulses is zero for Df1~Df6. ④ and ⑤ of the screen
 (Only one occurrence indicates malfunction.)

※ "Df1~Df6" shows the lens driving amount.

If the lens stops while inspecting the lens-servo stop accuracy, select "3.SET DELAY-TIME" and input a figure from 0 to 1000 for the delay time (msec: millisecond) to prevent stopping the lens into the entry field of "DELAY-TIME" of the below.

Note:

The value of "ADJUST DELAY-TIME" is set by the adjustment software. So, if the lens does not stop during the inspection of "LENS DRIVING STOP ACCURACY", any value can be input without problem.

However, the larger the value of "ADJUST DELAY-TIME" gets, the longer the inspection time becomes.

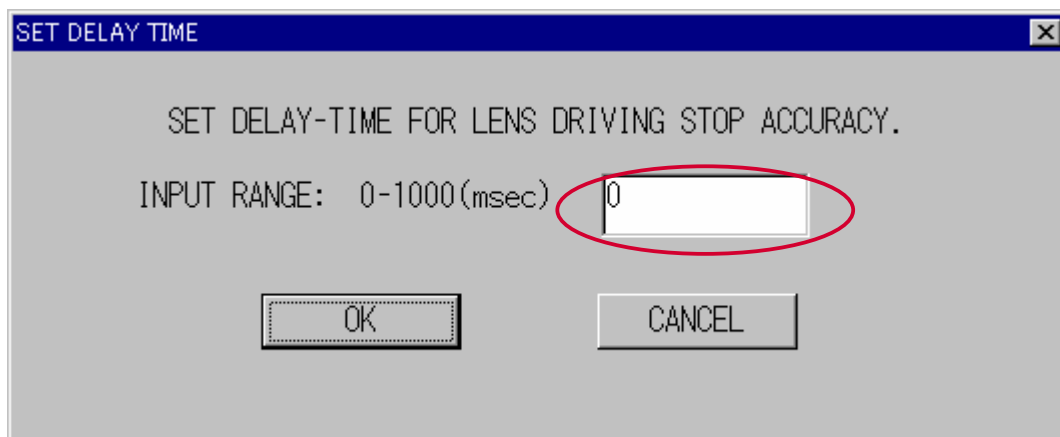
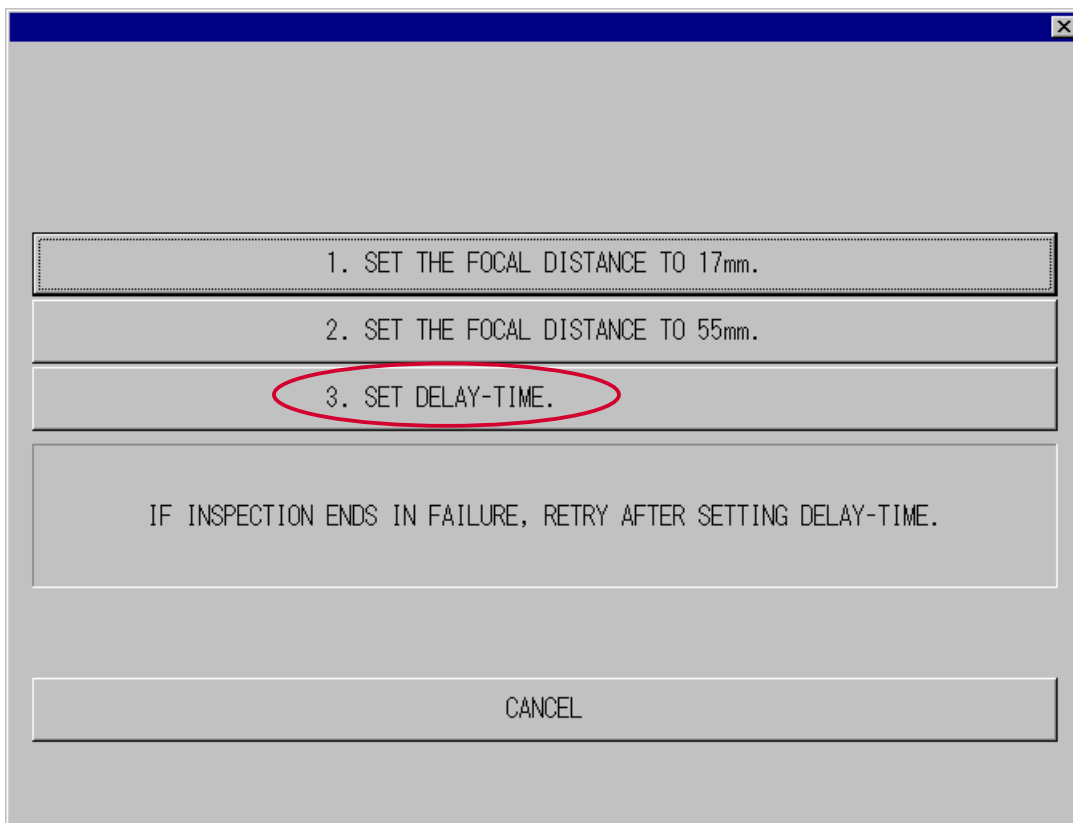

(4) Inspection of lens-servo time

INSPECTION OF LENS SERVO TIME.	
SERVO AMOUNT.	STANDARD.
1. [Df1]	50ms OR LESS.
2. [Df2]	62ms OR LESS.
3. [Df3]	81ms OR LESS.
4. [Df4]	101ms OR LESS.
5. [Df5]	125ms OR LESS.
6. [Df6]	145ms OR LESS.
7. DRIVE TO INFINITY.	
8. DRIVE TO CLOSE.	
9. RETURN TO FOCAL DISTANCE SET-UP MENU.	

Connect the probes of oscilloscope to E and H terminals of the AF-I communication box (J15306-1). Select the servo driving amount respectively. Each lens-servo drive time must be within the standard.

Caution : If the MF ring is rotated during inspections, the waveform shows an abnormal value. Do NOT touch the MF ring during inspections. Make inspections at the 5 positions as below.

(Lens position in inspecting)

Lens inclination	Position of index window
Horizontal	Up, right and left
Front lens group 90° upward	
Front lens group 90° downward	

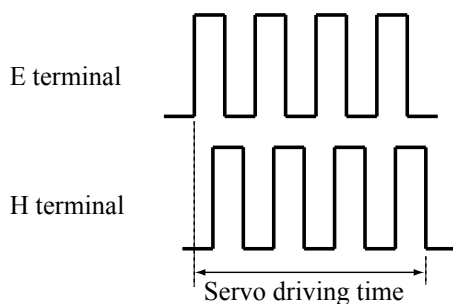

●Oscilloscope setting

- V/Div : 5V
- Coupling : DC
- Time/Div : 20 m Sec
- Trigger Mode : SGL (S)
- Trigger Coupling : DC
- Trigger Source : CH1

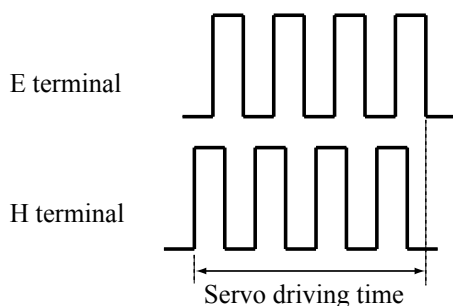

※ The waveforms of E and H terminals have the forms for going up for start and going down for start.

(5) Inspection of switches and lens conditions

①	TYPE OF LENS : AF-S 17-55mm/2.8G DX	CPU VERSION : 2.01.00 ← ②			
	SWITCHES AND LENS CONDITION	: FOCUSING ENCODER ZOOMING ENCODER :			
③	FOCUSING ENCODER : 0-1	: 0-1 17	0-1 18	:	
		: 0-2 18-1	0-2 19	:	
	ZOOMING ENCODER : 0	: 0-3 18-2	0-3 20	:	
		: 0-4	1 21	:	
④	LENS DRIVING MODE SELECTOR: M/A	: 1	2 22	:	
		: 2	3 23	:	
		: 3	4	:	
		: 4	5	:	
		: 5	6	:	
		: 6	7	:	
		: 7	8	:	
		: 8	9	:	
		: 9	10	:	
		: 10	11	:	
		: 11	12	:	
		: 12	13	:	
		: 13	14	:	
		: 14	15	:	
		: 15	16	:	
		: 16	17	:	

PUSH CANCEL TO RETURN TO MENU.

CANCEL

① Type of lens.

② The version of CPU in the lens.

③ The signals of the focusing encoder and zooming encoder.

The value changes by turning the MF ring with M or M/A of the lens driving mode selector.

④ The status of Switches

REAR COVER

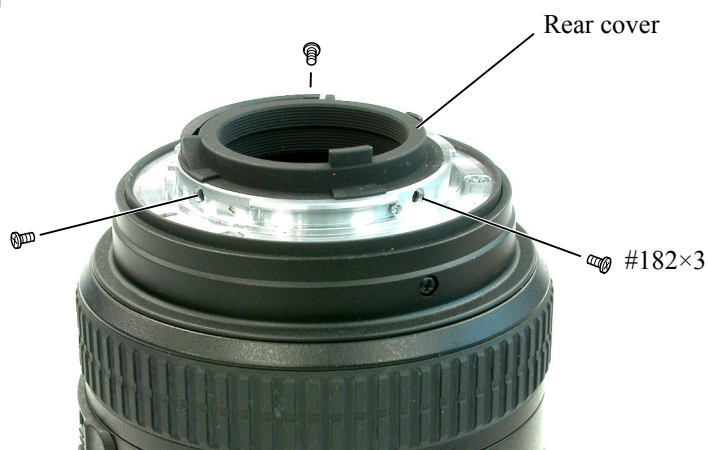

Aberration compensation data writing adjustment

- This adjustment uses the software which calculates the aberration compensation data according to the feature of lens aberration and writes in EEPROM of the lens, in order to improve the accuracy of autofocus.

Note: This adjustment is necessary when the main PCB and/or each lens part (glass, lens chamber) is replaced or when each lens part is disassembled. Be sure to make this adjustment after completing inspecting and adjusting the main PCB.

(1) Preparation

- Test chart (Self-made tool: ref. Procedure for how to create it.)
- Tripod
- D100
- Personal computer
- USB cable (UC-E4)
- Adjustment software (LWM.exe : used for the lens optical alignment.)

(2) Procedure for how to create Test chart

- Photocopy the next page and cut out 1 target chart and 5 resolution charts.

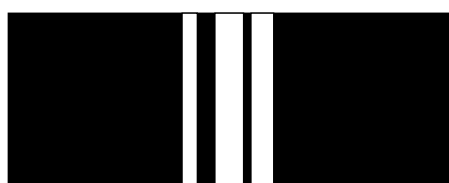

(Target chart)



(Resolution chart)

- As shown below, put each chart in position at the specified spacings.

Note: Only about the center, put the target chart on the central resolution chart.

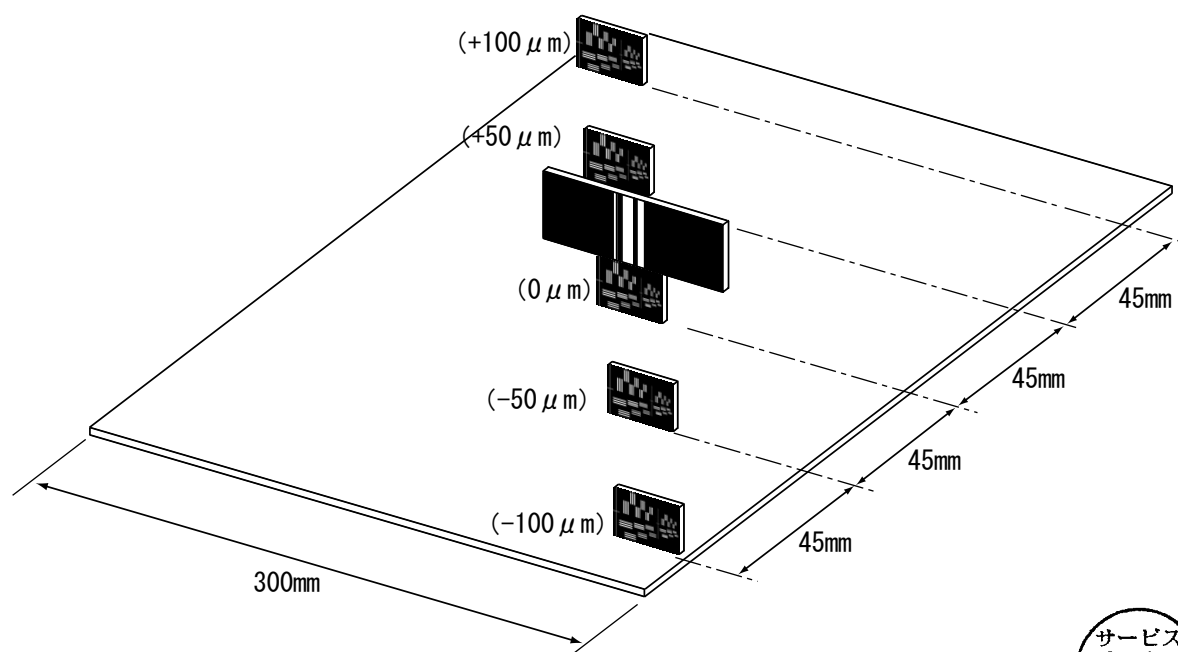

(Target chart)



(Resolution chart)

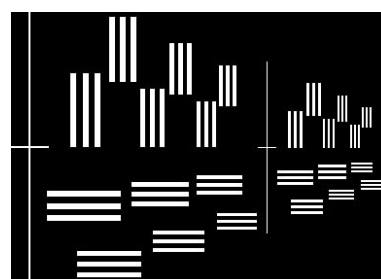

(3) Writing aberration compensation data

- ① Prepare a camera (D100). Set the "Exposure mode" to "A" for full aperture and "Focus mode" to "S".
On the shooting menu, set the "Image quality mode" to "FINE", "Image size" to "L", "WB" to "Preset", and "ISO" to "200".
- ② Set up the camera (D100), in which the lens to be inspected is fit, on the tripod. Set the focal length to 55 mm, and the distance between the test chart and camera (CCD face) to $2\text{ m } 20 \pm 2\text{ cm}$.

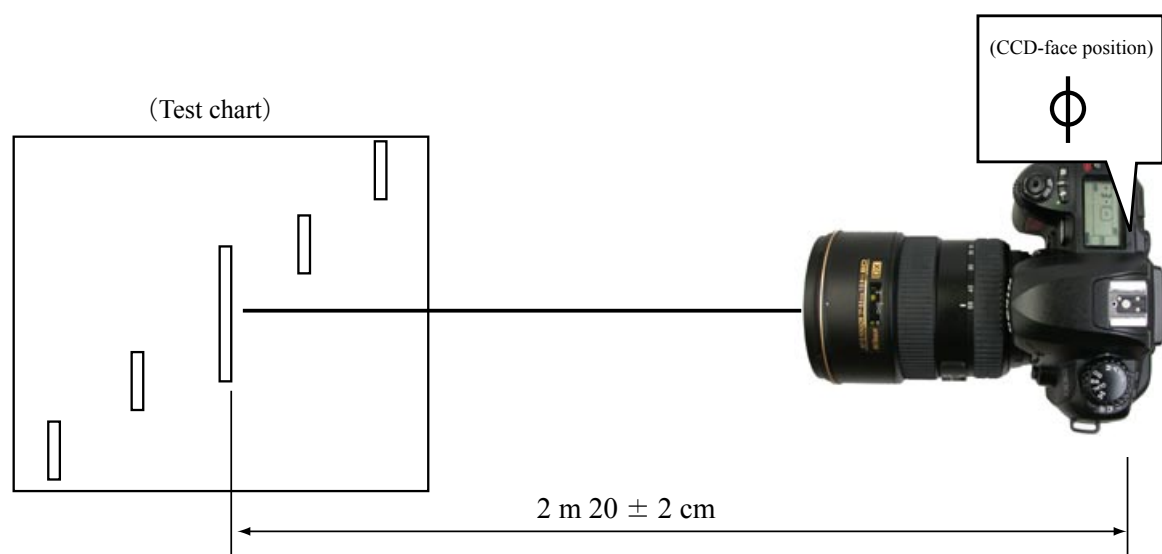

- ③ As shown below, bring the target chart in the center of focus area within viewfinder.

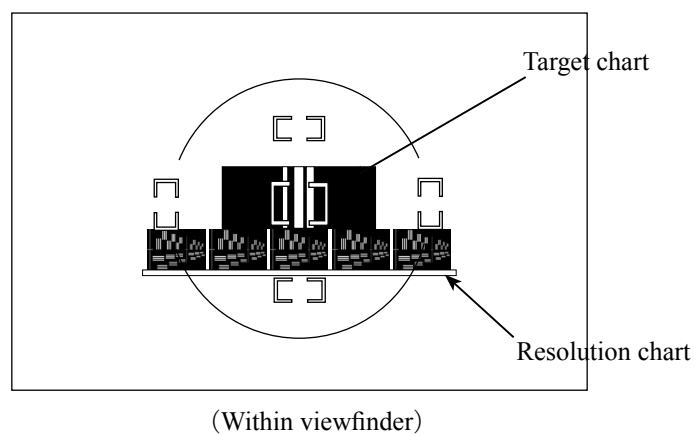

- ④ Connect the PC and camera via USB cable. (Camera setting: Mass storage)
- ⑤ Start the adjustment software (LWM.exe).



- ⑥ Click the "Defocus rectify..." button.

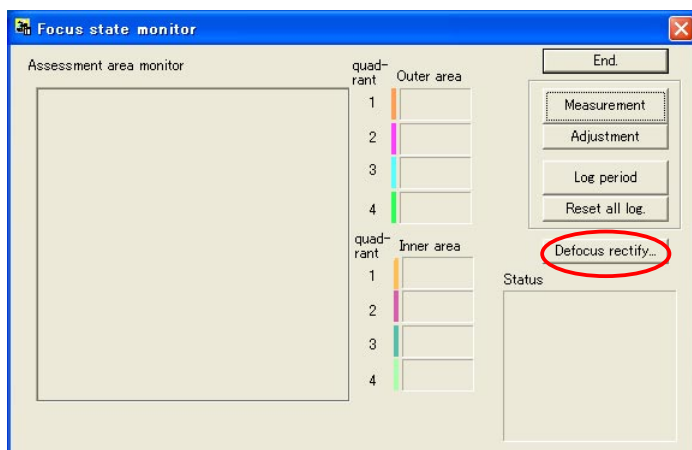

- ⑦ Click the "JPEG Shot" button.

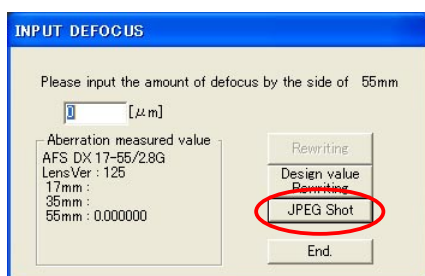

- ⑧ The shutter is released after the AF operation. The shot image is automatically displayed on the PC screen. Scale the image to 100% and check which chart is in focus of the 5 resolution charts.

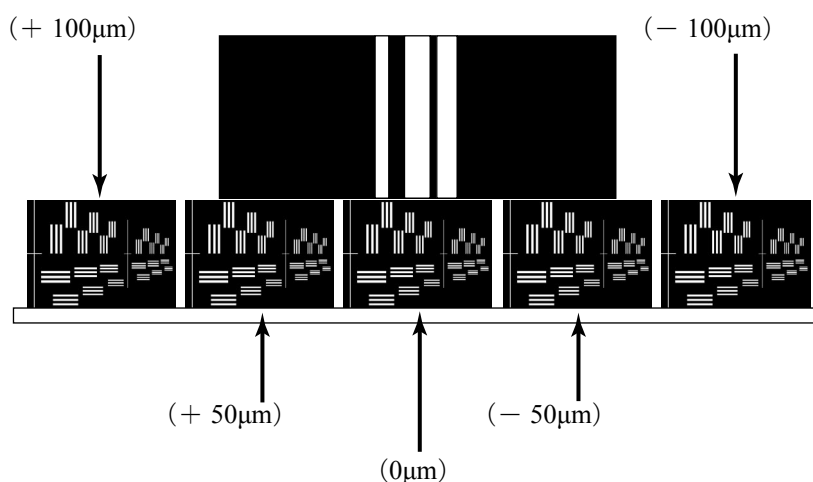

- ⑨ Input the value of the focused position into the entry field.

e.g. The below is the case when " - 100μm" of the front focus side is in focus.

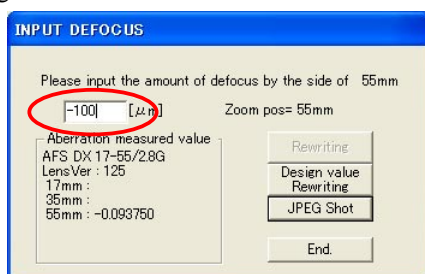

- ⑩ Set the focal length of the lens to 35 mm, and the distance between the test chart and camera (CCD face) to 1 m 40 ± 2 cm.

- ⑪ Perform the operations from ⑦ to ⑨ of the previous page.

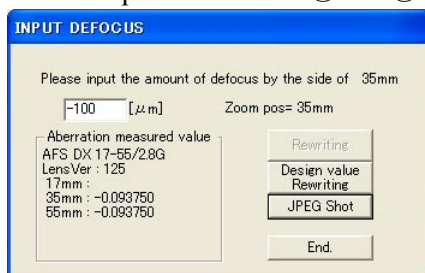

- ⑫ Set the focal length of the lens to 17 mm, and the distance between the test chart and camera (CCD face) to 68 ± 2 cm.

- ⑬ Perform the operations from ⑦ to ⑨ of the previous page.

- ⑭ Check that the values of all the focal lengths are displayed within the dotted red circle. Then click on "Rewriting".

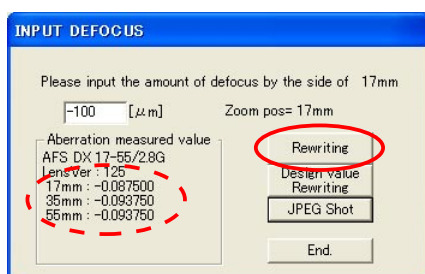

- ⑮ When "A compensation value is written in." is displayed, click "OK".

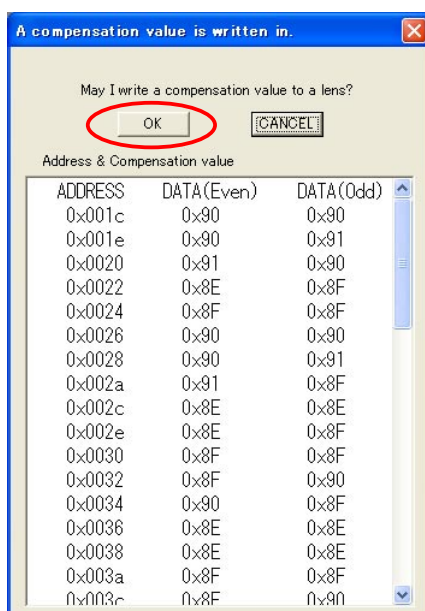

- ⑩ The reconfirmation screen is displayed. Click "OK".

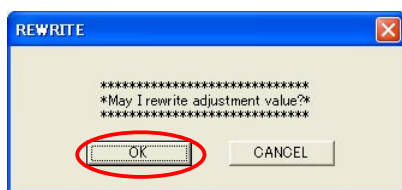

- ⑪ An hourglass is displayed on the screen, and writing starts.

The below screen is displayed after a few seconds. Turn camera OFF and turn it ON again.

Click "OK", and the adjustment software restarts.

Note: Unless the camera is turned off once, the value that was written in EEPROM is not reflected on the results of shooting.

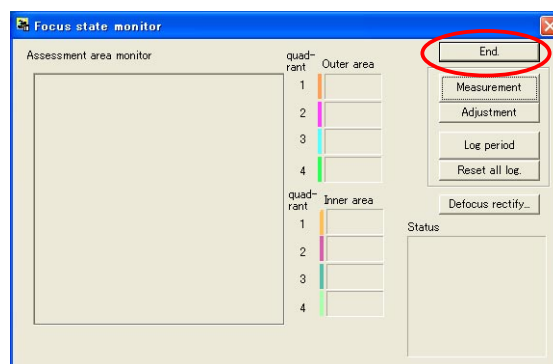
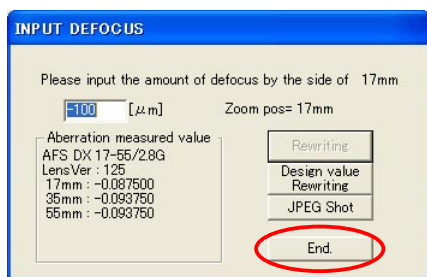
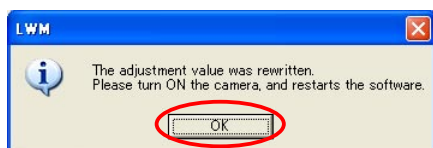

- ⑫ When the adjustment software restarts, perform the operations from ② to ⑬ again. Check that "0μm" of the AF position is in focus.

(It is also possible, after Wide-side shooting of ⑫, to take the Middle-side shooting of ⑩ and the Tele-side shooting of ②.)

If "0μm" is not in focus, repeat the operations from ② to ⑫.

If it is not still in focus even after repetition, the written value in EEPROM may be abnormal. So click "Design value Rewriting" to write the initial value, then proceed with the operations.

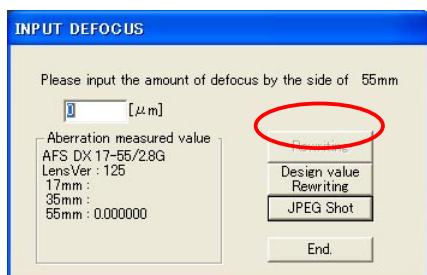





When replacing a part listed below,
Some adjustment may be required

Item of Adjustment \ Parts Replaced	Adjustment for MR duty (Necessary to write fixed value) Adjustment for frequency control	Inspection and adjustment for the waveform output from MR encoder
Main PCB	○	
SWM	○	
MR HEAD UNIT	○	○

TOOLS

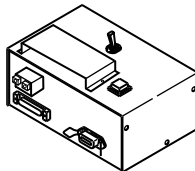
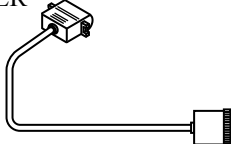
★ :New tool

RJ No.	Name	Note
MZ-800S	DRY SURF MZ-800S	
GE-8	GREASE GE8	
EDB0011	SCREW LOCK 1401C	
L-241	LOCK END	
J18004-1	STANDARD GAUGE FOR J18004 	
J19002	BACK FOCUS COLLIMATOR LT-500S	
J18028	LENS ADAPTER FOR FOCUS TESTER 	
★ J18364	INSPECTION AND ADJUSTMENT SOFTWARE FOR AF-S ZoomDX17-55/2.8G 	
J15306-1	AF-I COMMUNICATION BOX 	
J15307	AF-I COMMUNICATION ADAPTER 	
	PERSONAL COMPUTER	
	POWER SUPPLY	
	OSCILLOSCOPE	
★ J11303A	WRENCH FOR 2ND LENS GROUP	
★ J11303B	SUPPORT TOOL FOR 2ND LENS GROUP	
★ J11303C	SUPPORT TOOL PIN FOR 2ND LENS GROUP	
★ J11304	WRENCH FOR 3RD LENS GROUP	
★ J11305	WRENCH FOR 4TH LENS GROUP	
	POINT TESTER	
	SELF-MADE TOOL 	Use the self-made tool that was created for AF-S24-85/3.5-5.6G

Making of self-made tool

- To inspect and adjust the output waveform of MR encoder, it is necessary to make a self-made tool by using the main PCB of repair parts.

The making procedure is shown below. Make a self-made tool according to this procedure.

This tool is the same one that was made for AF-S24-85/3.5-4.

Use the same main PCB that was used for AF-S24-85/3.5-4G.

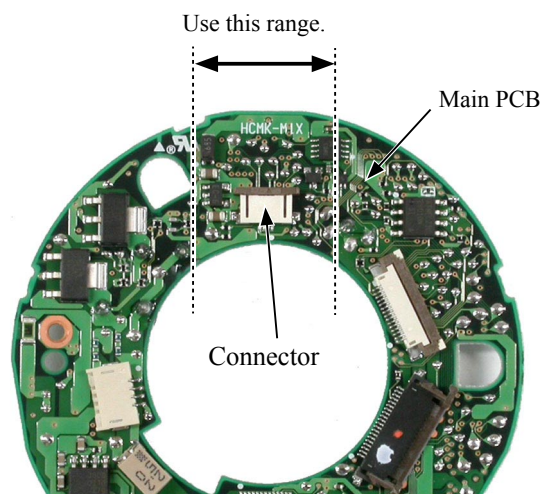

- ① Remove the mounted parts/elements (condenser, transistor, IC, etc.) from both sides of PCB, within the range of the left dotted lines . Do not remove the connector.

- ② Cut off the PCB along the dotted lines.

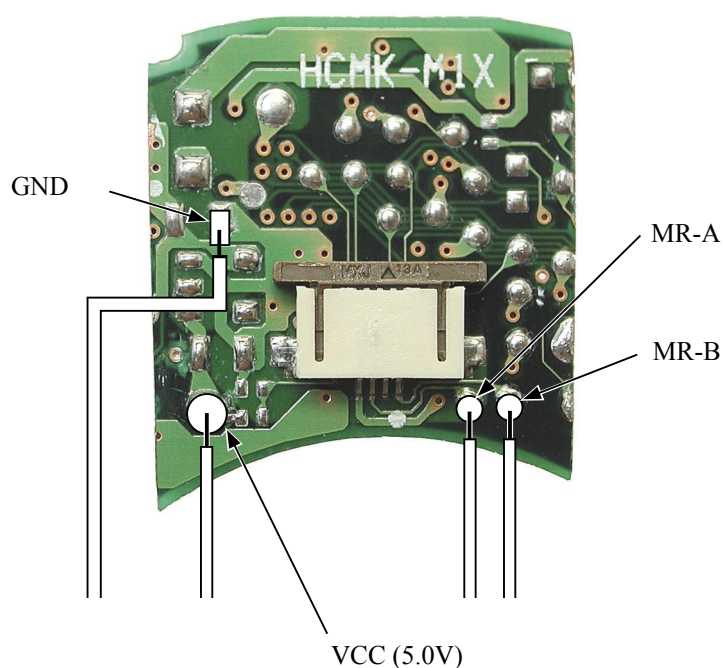

- ③ Solder the wires on the PCB pattern at 4 parts as shown left.

外觀図 Sketch drawings

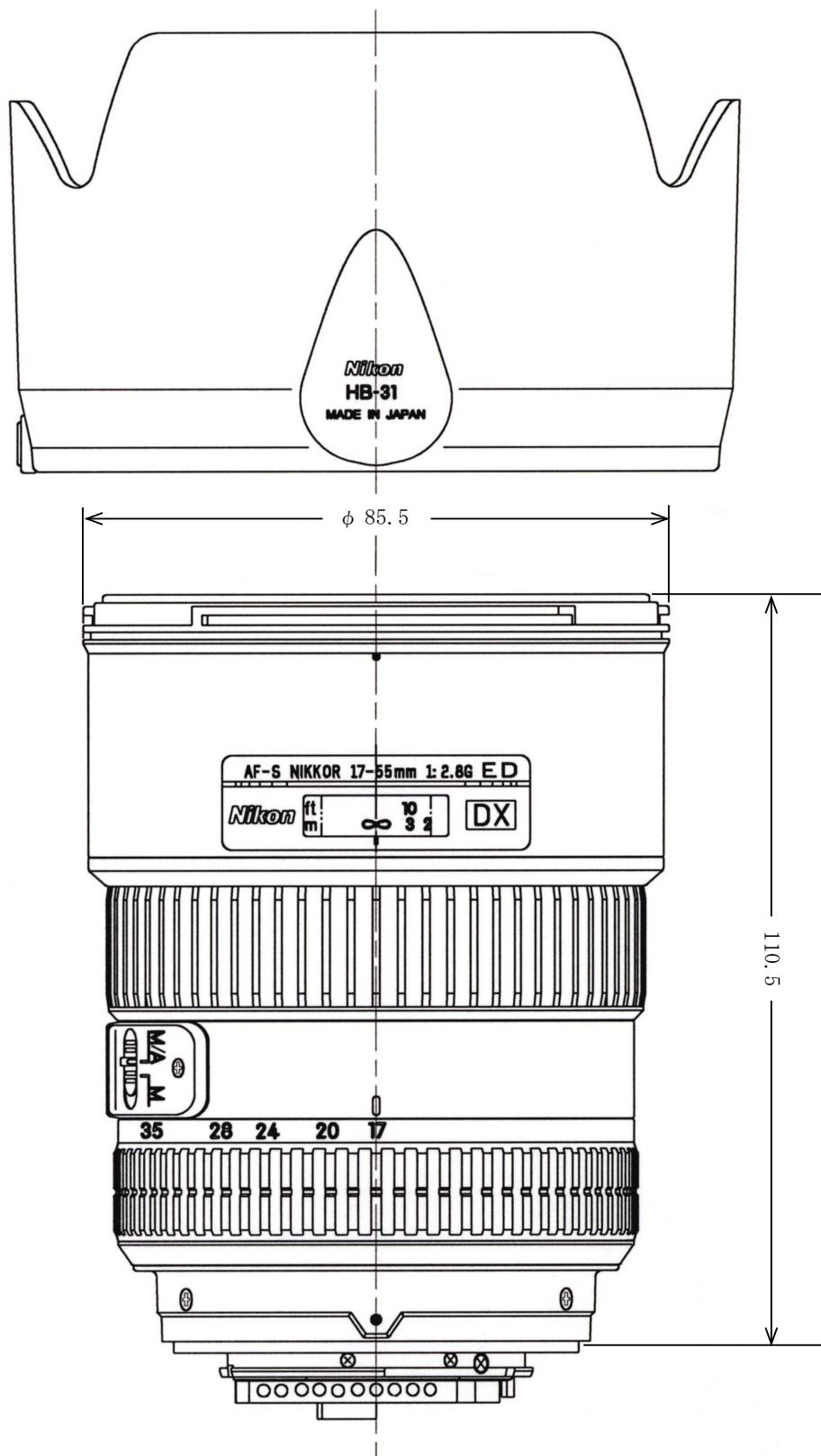

組立図 Structure of the Lens

