

作成承認印

配布許可印



AF-S DXZoom-Nikkor ED 12-24mm f/4G IF

REPAIR MANUAL

Nikon | NIKON CORPORATION
Tokyo, Japan

SPECIFICATIONS

This lens can be used for Nikon digital SLR camera only.

Type of lens	G-type AF Zoom- Nikkor lens having built-in CPU and Nikon F bayonet mount
Focal length	12mm - 24mm (18 - 36 mm in 35 mm format)
Maximum aperture	f/4
Lens construction	11 elements in 7 groups (3 aspherical lens and 2 ED lens elements)
Picture angle	99° - 61° (with Nikon Digital Camera D1/D1H/D1X/D100)
Focal length scale	12,15,18,20,24mm
Distance information	Output to camera body
Zoom control	Manually via separate zoom ring
Focusing	Nikon Internal Focusing (IF) system (utilizing an internal Silent Wave Motor); manually via separate focus ring
Shooting distance scale	Graduated in meters and feet from 0.3m (1ft.) to infinity (∞)
Closest focus distance	0.3m (1ft.) at all zoom settings
Diaphragm	Fully automatic
Aperture range	f/4-22 at all zoom settings
Exposure measurement	Via full-aperture method with cameras having CPU interface system
Attachment size	77mm (P=0.75mm)
Dimensions	Approx. 82.5mm dia. ×90mm extension from the camera's lens mount flange
Weight	Approx.485g

Disassembly

1ST LENS GROUP



FILTER RING



- Remove the rubber ring (#35).
- Remove the blindfolding-cover (#103).
- Unscrew #79.
- Take out 4 screws (#104).
- Remove the filter ring.

ZOOM RING



- Unscrew #87.
- Unscrew #66.
- Remove the encoder brush (B4).
- Remove the zoom ring.

Note :

The convex 3 parts of the zoom ring are grooved in #22.

So remove the zoom ring by turning it to the position where the convex parts detach from the groove.



REAR COVER RING

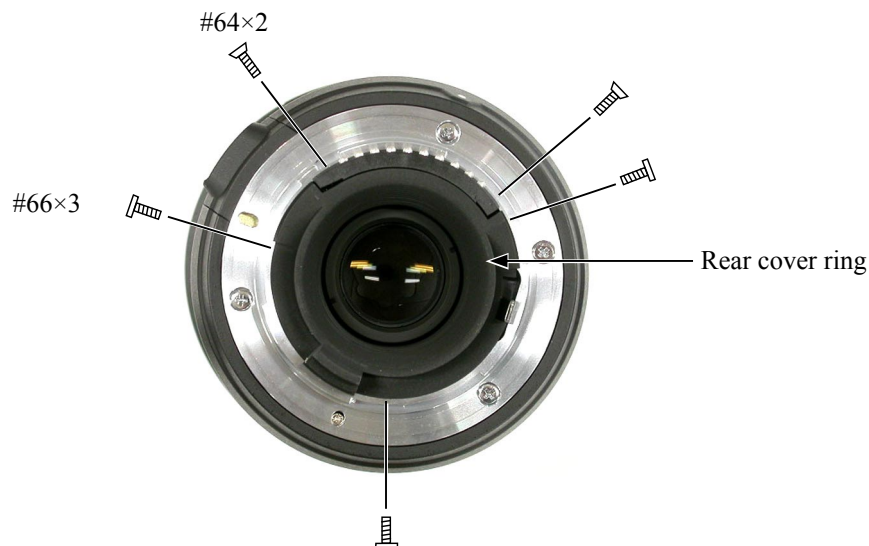

BAYONET

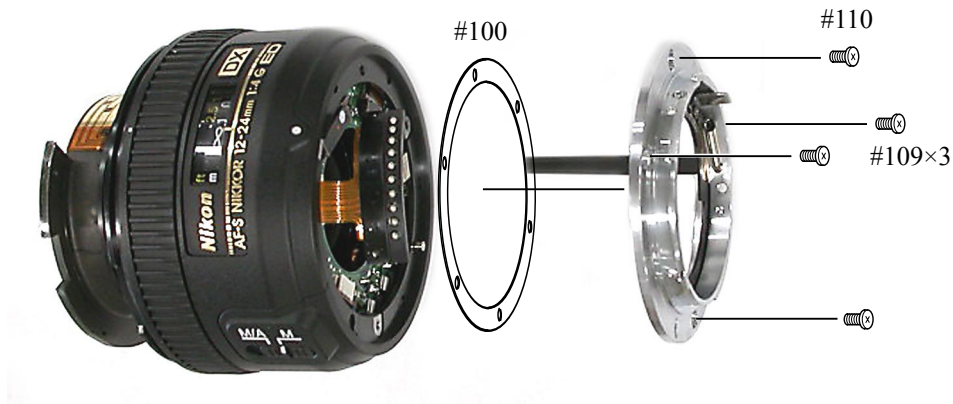

INDEX RING, FOCUS RING

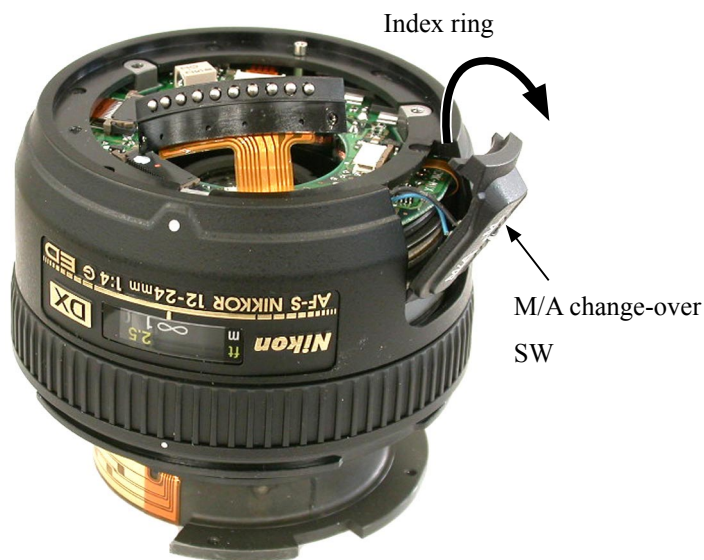

Fig. 1.

- Detach the M/A change-over SW from the index ring by sliding it as shown in Fig. 1.
- Remove the index ring.
- Remove the focus ring.

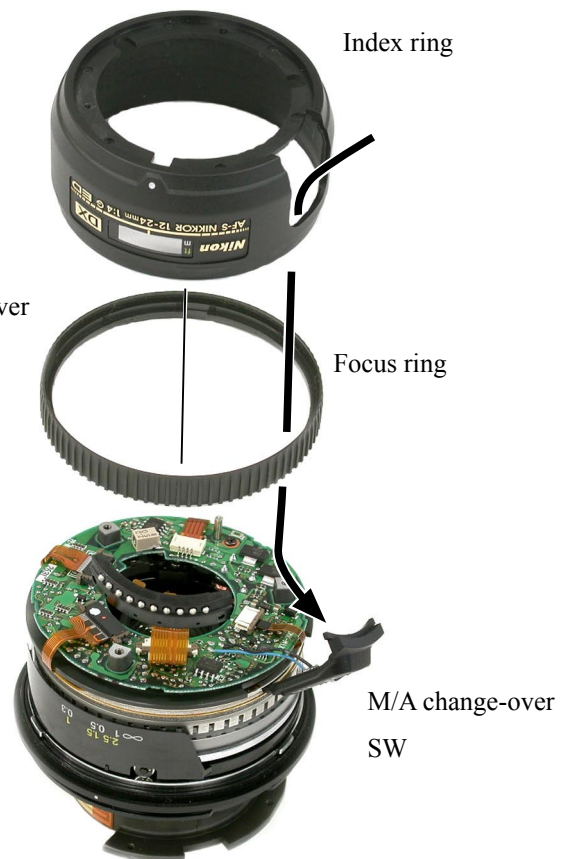
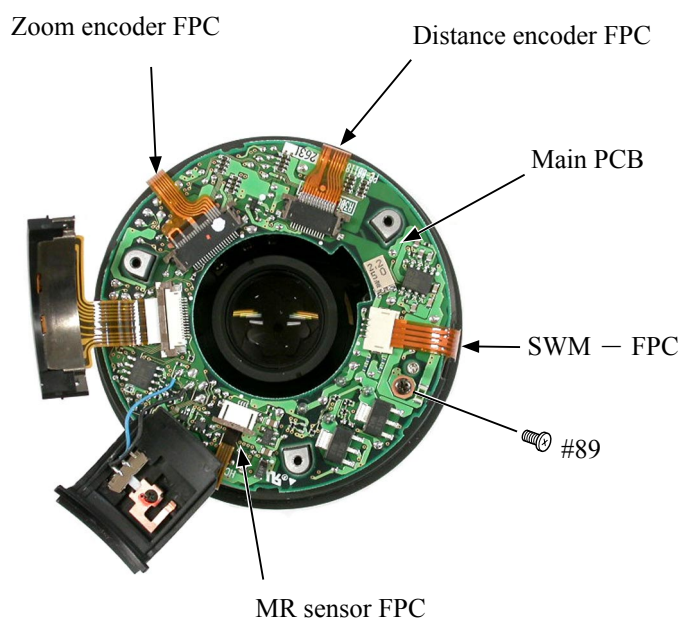

Fig. 2.

Note : Pass the M/A change-over SW through the hole of the index ring as shown in Fig. 2.

MAIN PCB



- Remove the FPCs (positioned at 4 parts) from the connector.
- Unscrew #89.
- Remove the main PCB.

SWM UNIT

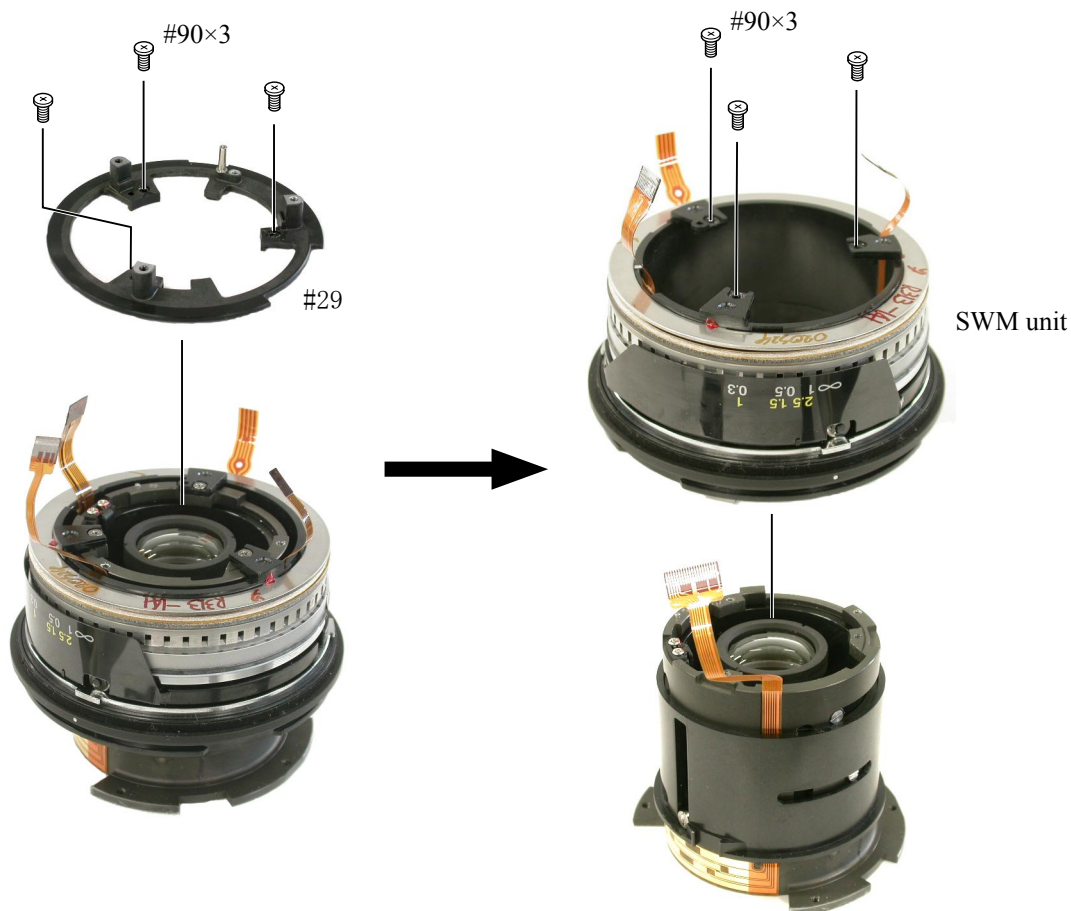

CAM RING UNIT

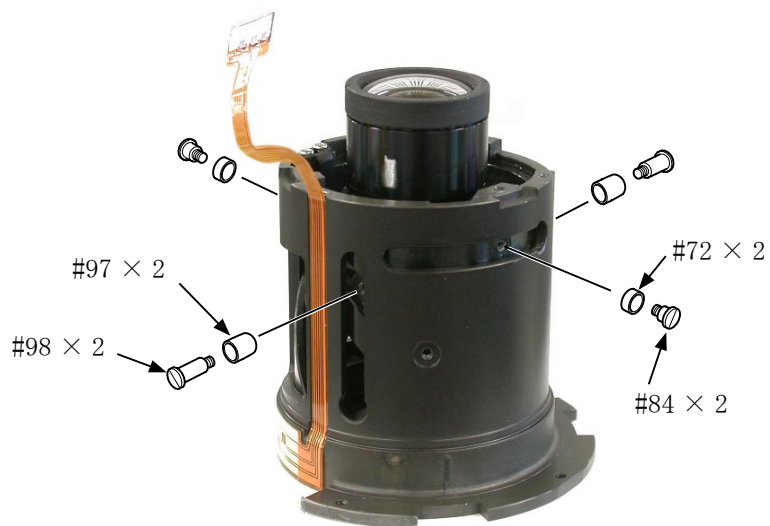
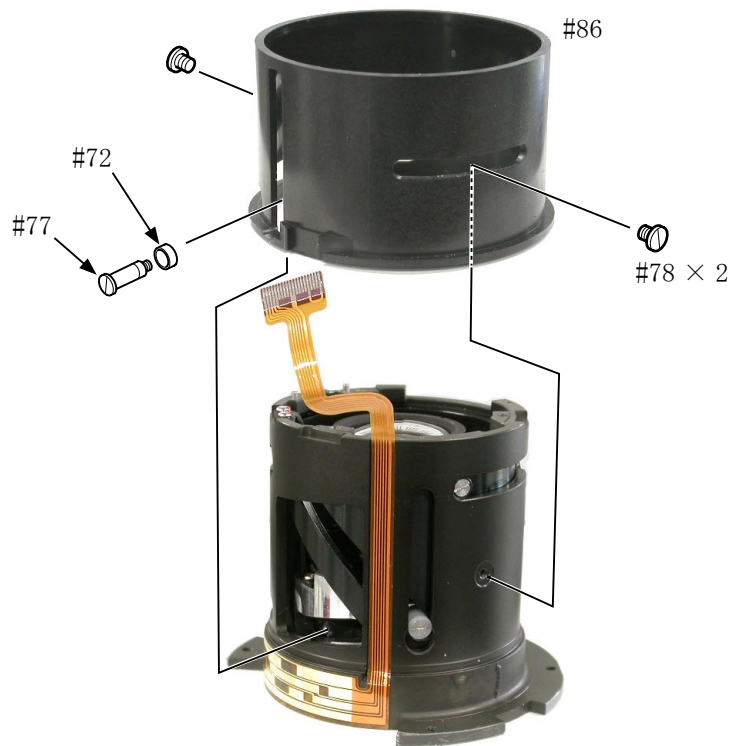

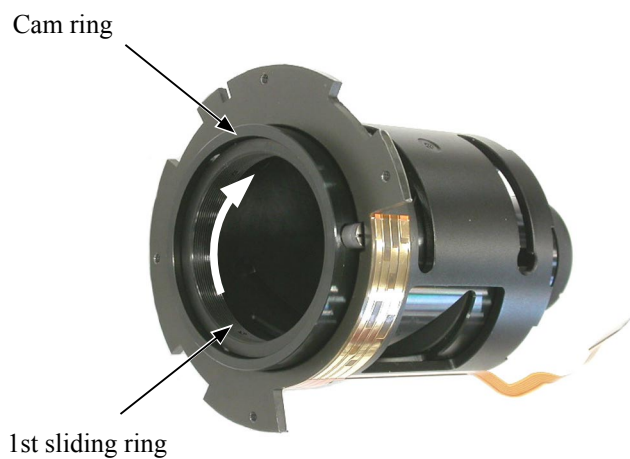

- Take out the cam ring by turning the 1st sliding ring in the direction indicated by the arrow.
- Detach the 2nd and 3rd units from the cam ring.

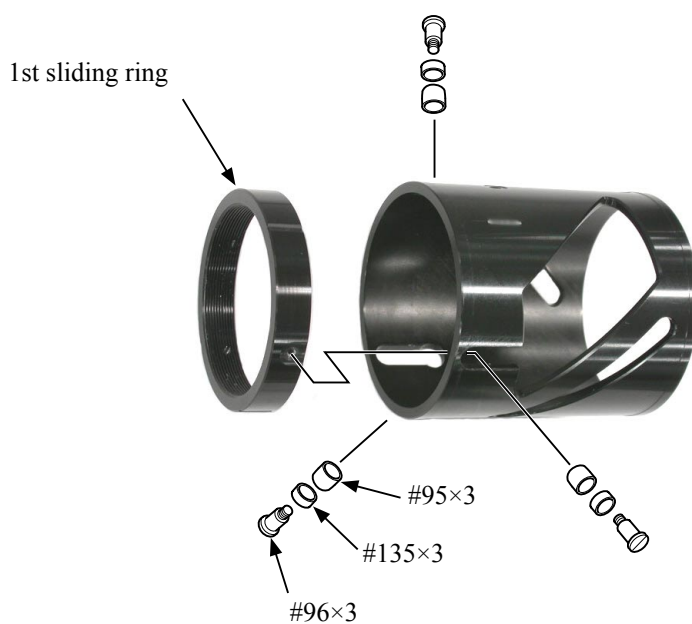
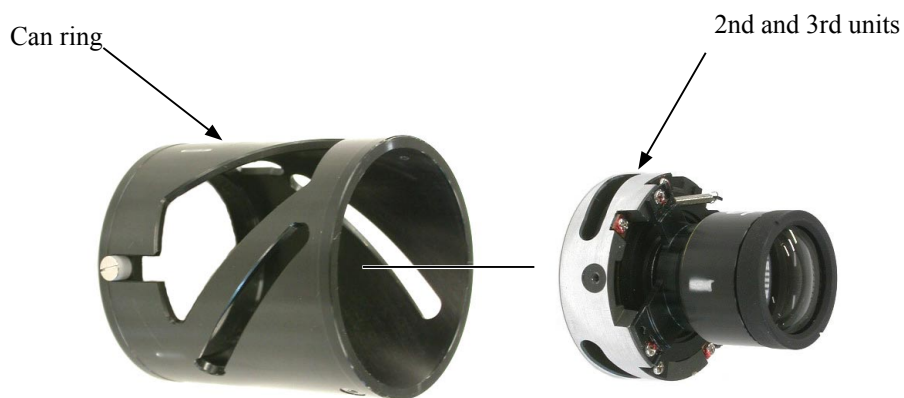

2ND LENS GROUP



3RD LENS GROUP

Note :

If the 3rd lens group is removed, the shaft alignment is necessary after assembling.

If the shaft alignment is impossible in your service offices, do not remove the 3rd lens group.



Assembly

APERTURE BLADE HOUSING UNIT

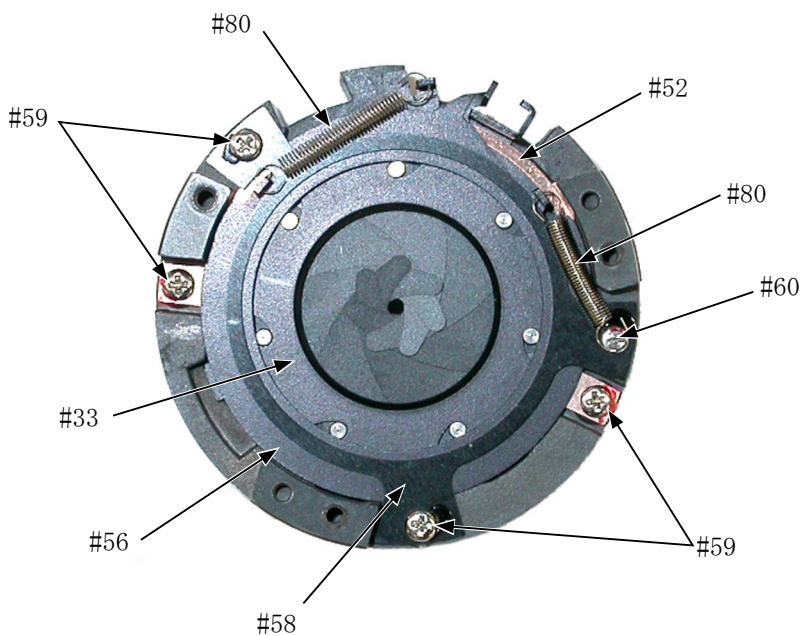
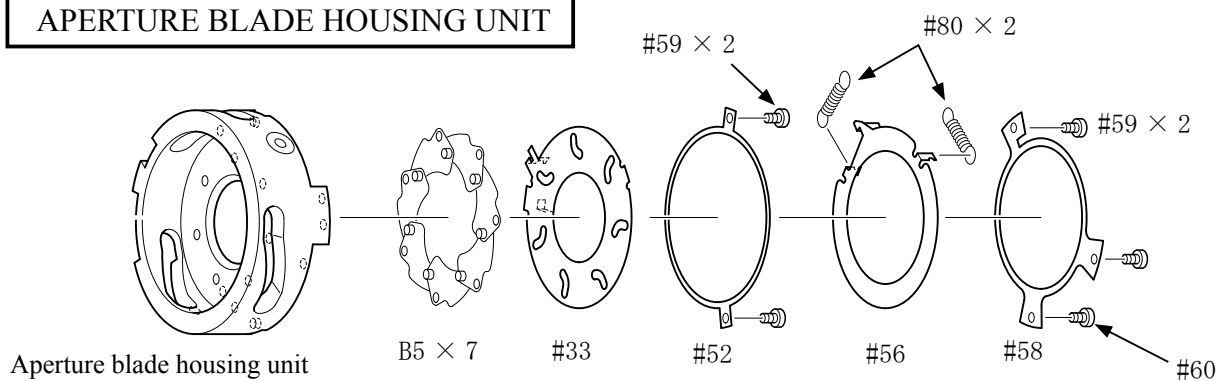

3RD LENS GROUP



2ND LENS GROUP

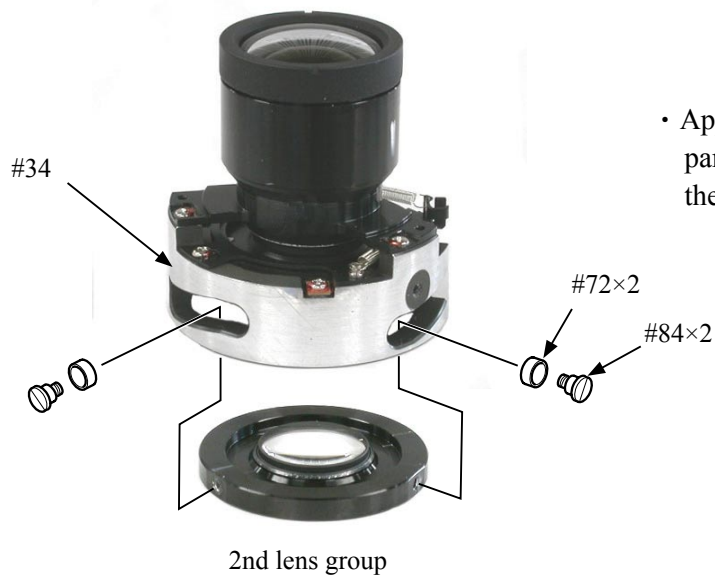

- Apply the grease (GE-8) to 3 parts of the cam groove and the all-round of #34.

1ST SLIDING RING

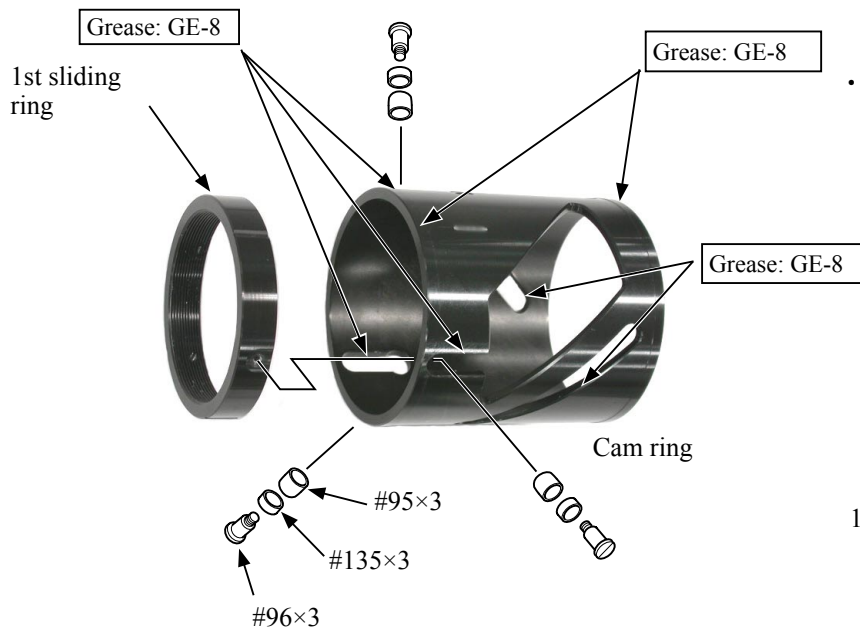

- Apply the grease (GE-8) to 5 parts of the cam groove and across stepped parts.
- Assemble the 1st sliding ring at the below position.

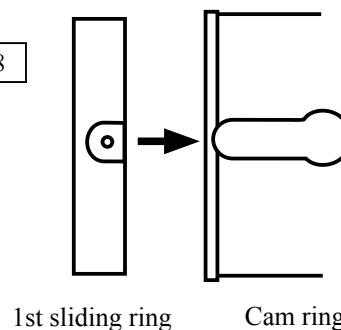

LIMIT PLATE

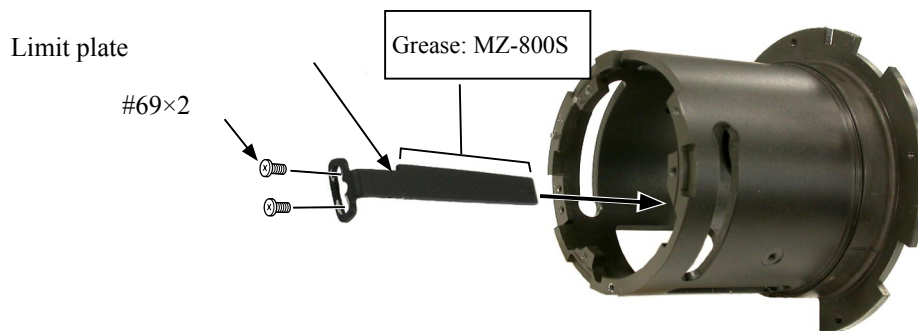

ZOOM ENCODER FPC

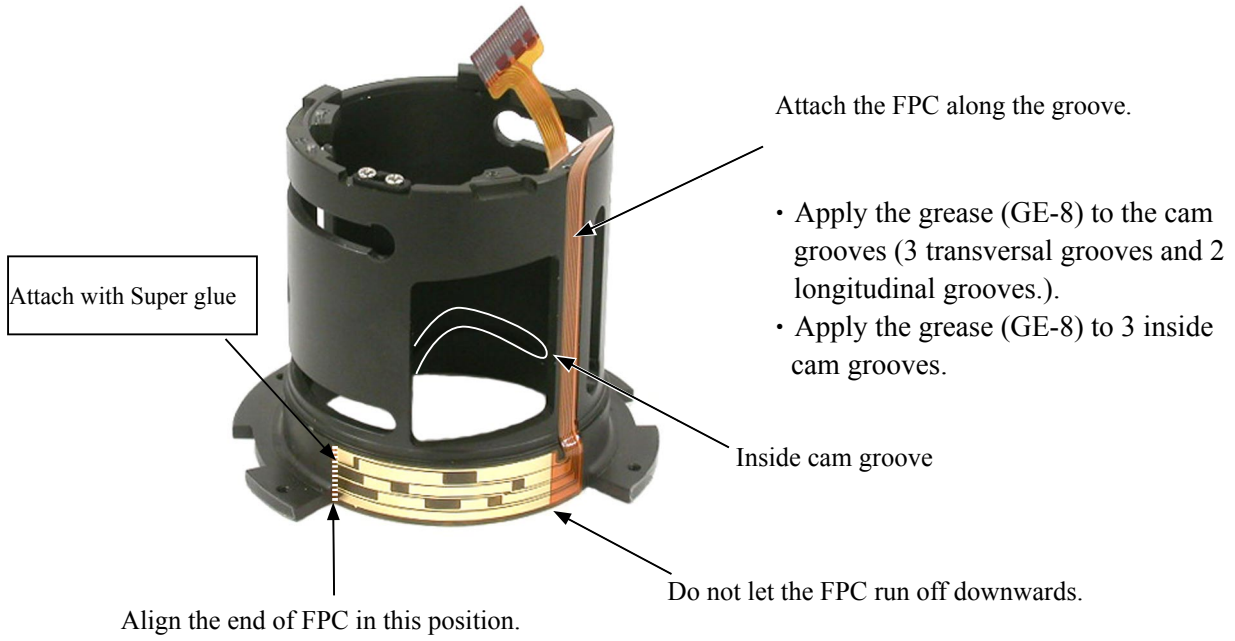

CAM RING UNIT

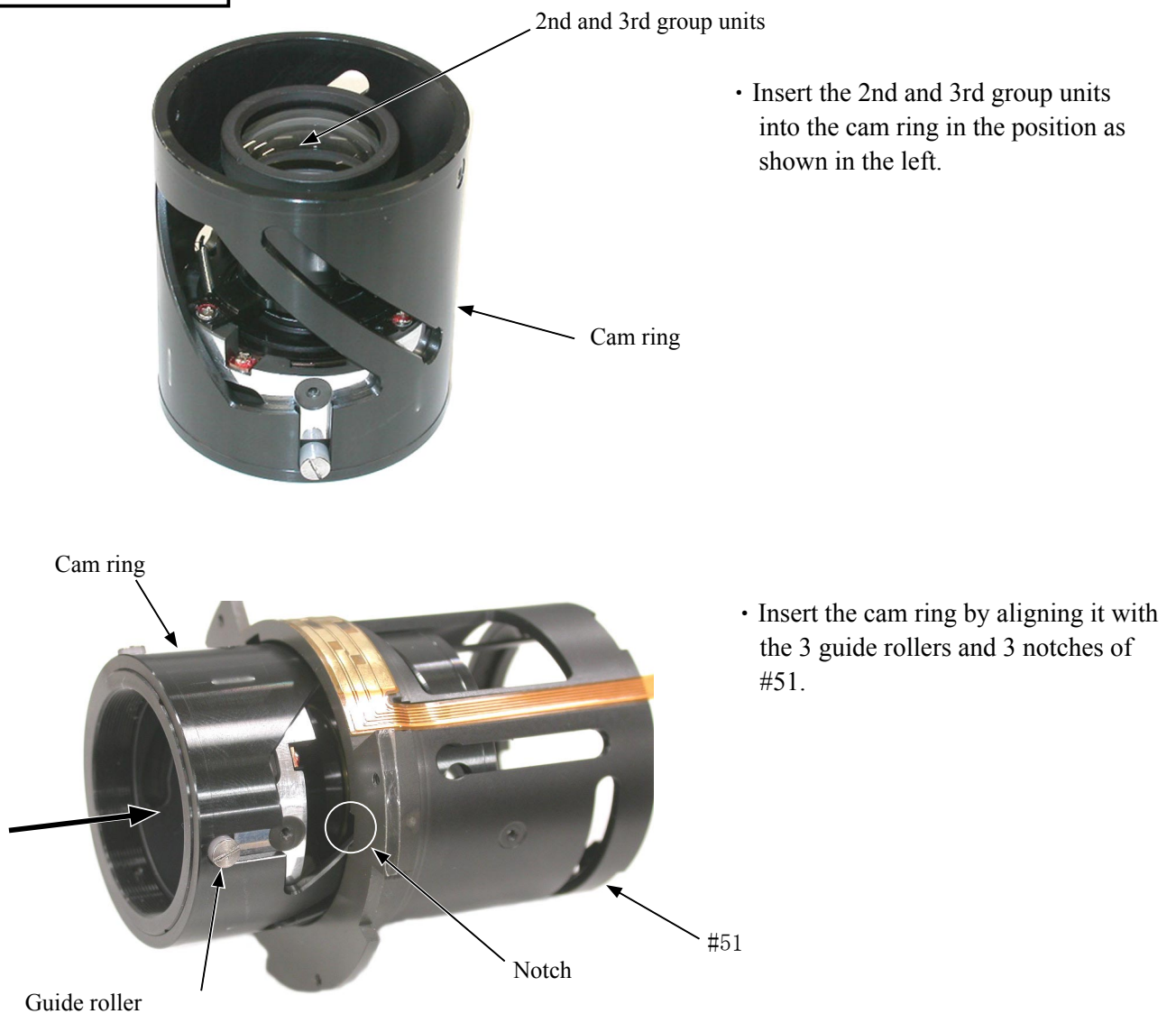

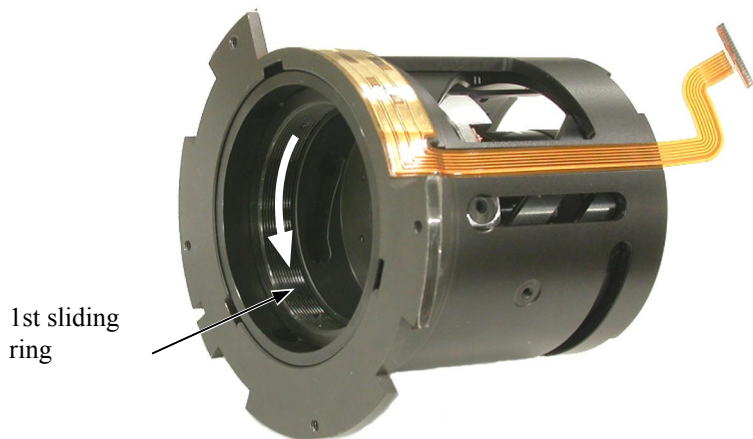

- Turn the 1st sliding ring in the direction indicated by the arrow.

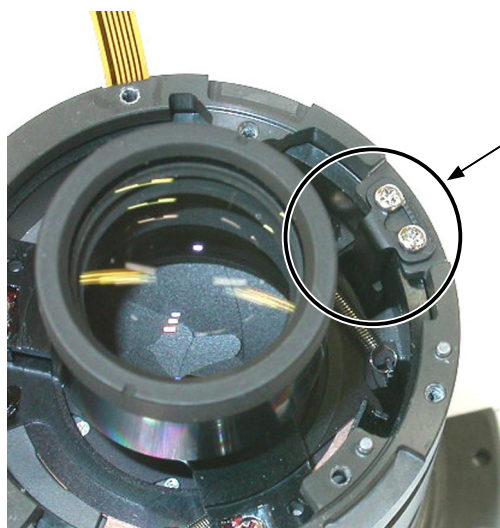

Make sure that the limit plate is entered in the notches of the 2nd and 3rd group units.

- Apply the grease (MZ-800S) to the 1 longitudinal groove and 3 transversal grooves of #86.

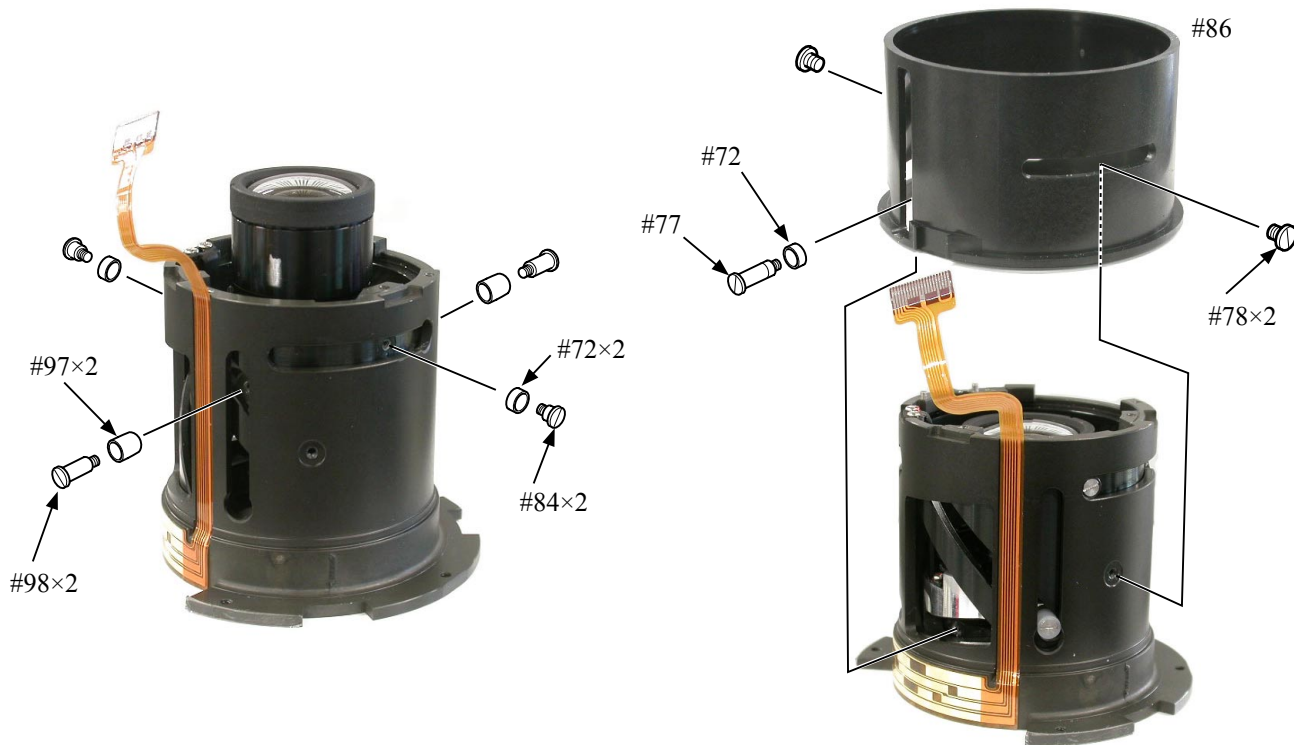

POSITION ADJUSTMENT OF LIMIT PLATE

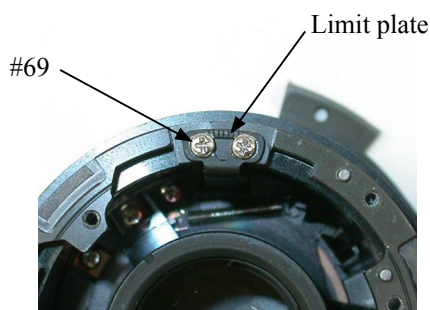

- Fix the limit plate in the center.
- As shown in Fig. 1., assemble #29 and the bayonet.
The aperture lever (#55) is put into A of Fig. 2.

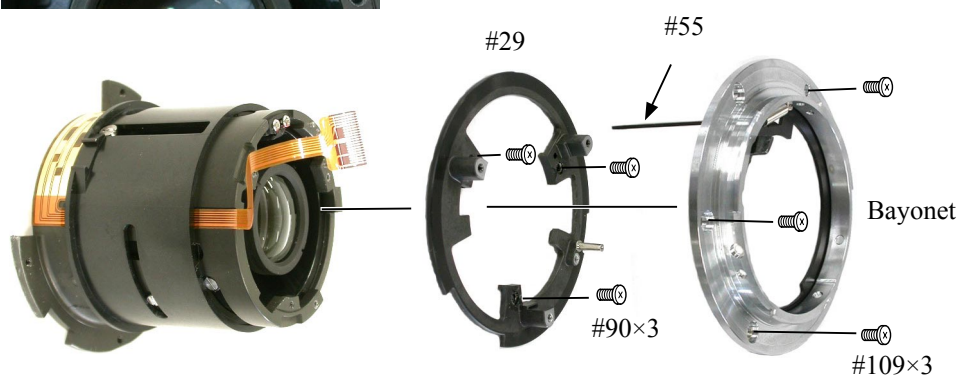

Fig. 1.

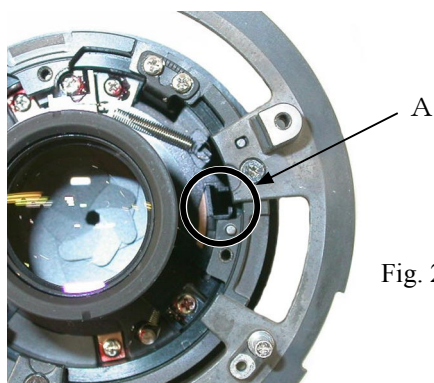
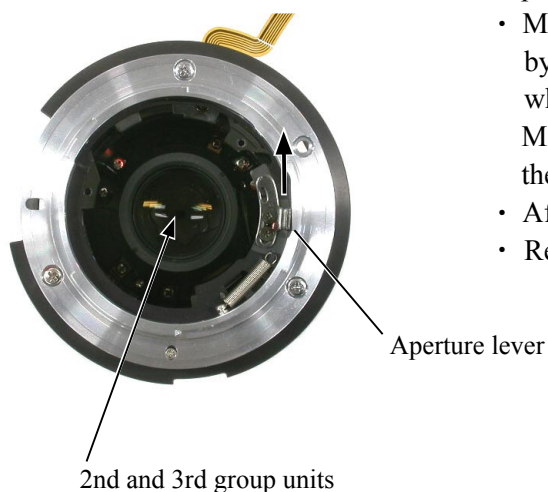
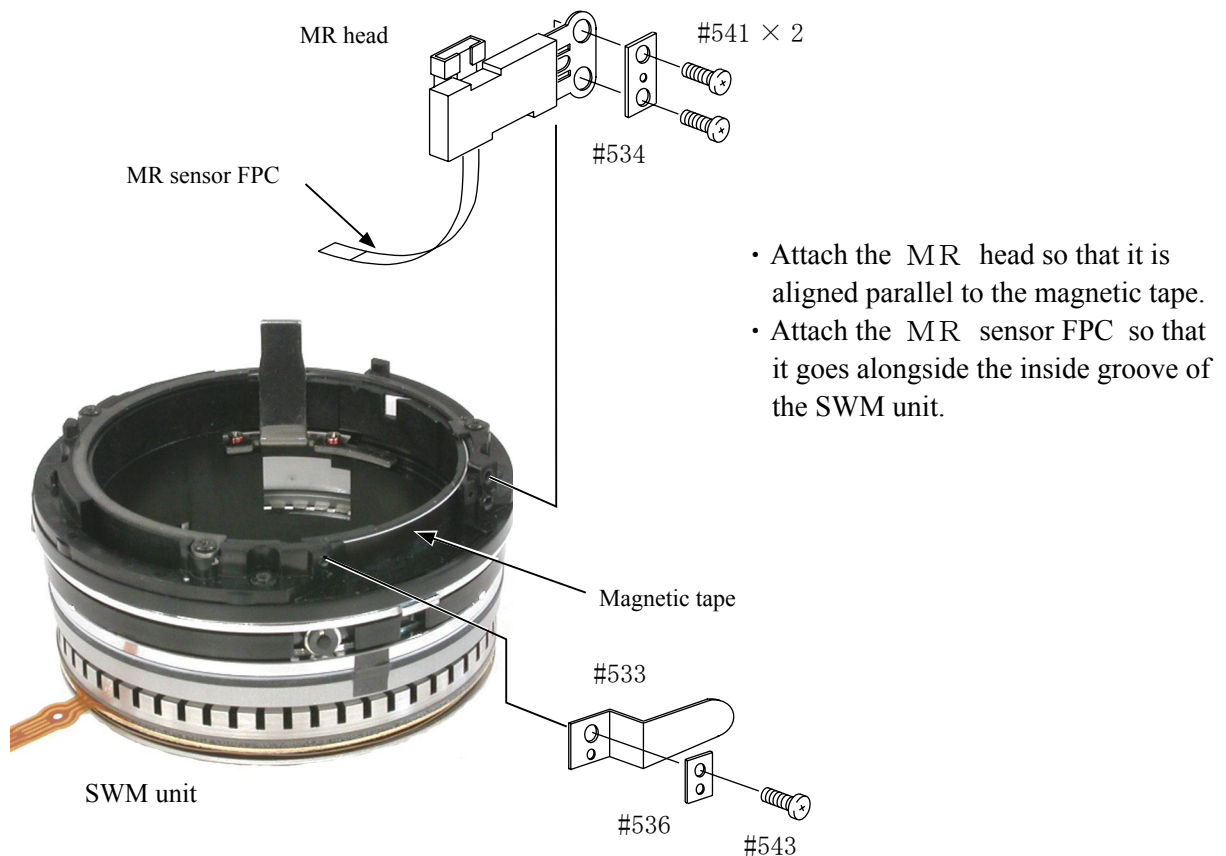

Fig. 2.



- Turn the zoom to TELE side.
(to the position where the 2nd and 3rd lens units are pushed downward.)
- Move the aperture lever slowly in the direction indicated by the arrow, and make sure of being the full aperture when the aperture blades stop.
Make adjustments by changing the position of attaching the limit plate.
- After adjusting, apply the Screw Lock to #69.
- Remove #29 and the bayonet.

MR HEAD



INSPECTION AND ADJUSTMENT FOR THE WAVEFORM OUTPUT FROM MR ENCODER

●In case of disassembling or replacing the MR head, be sure to make adjustments.

1. Equipment and tools to be required

- Single output rated voltage power supply: 1 unit With 5.0V and 100mA, applicable to the self-made tool
- Oscilloscope: 1 unit
- Self-made tool: 1 unit

Note : In case of any trouble in continuity between the self-made tool and the contacts of relay FPC, there may be dust, corrosion or oxidation on the contact surface of relay FPC. Be sure to polish the contact surface prior to connect to the self-made tool.

2. Preparation for the measuring lens

- Set the SWM unit on which the MR head is already set, the MF ring, the rear fixing tube, and the index ring into the cam ring unit. Then connect to the measuring devices. (Refer to the next page.)

Note: When make checks and adjustments, put a cloth under the lens to avoid any damages to the rear lens.

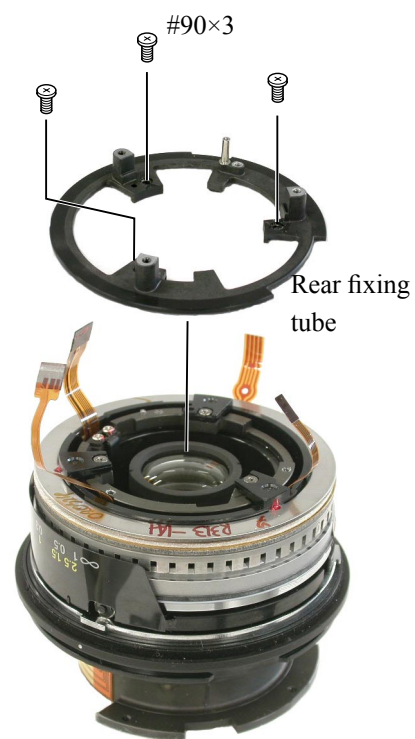
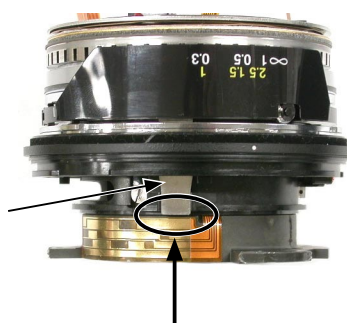
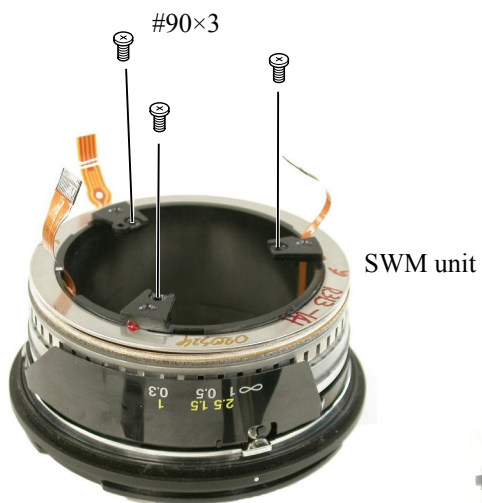

• Connections

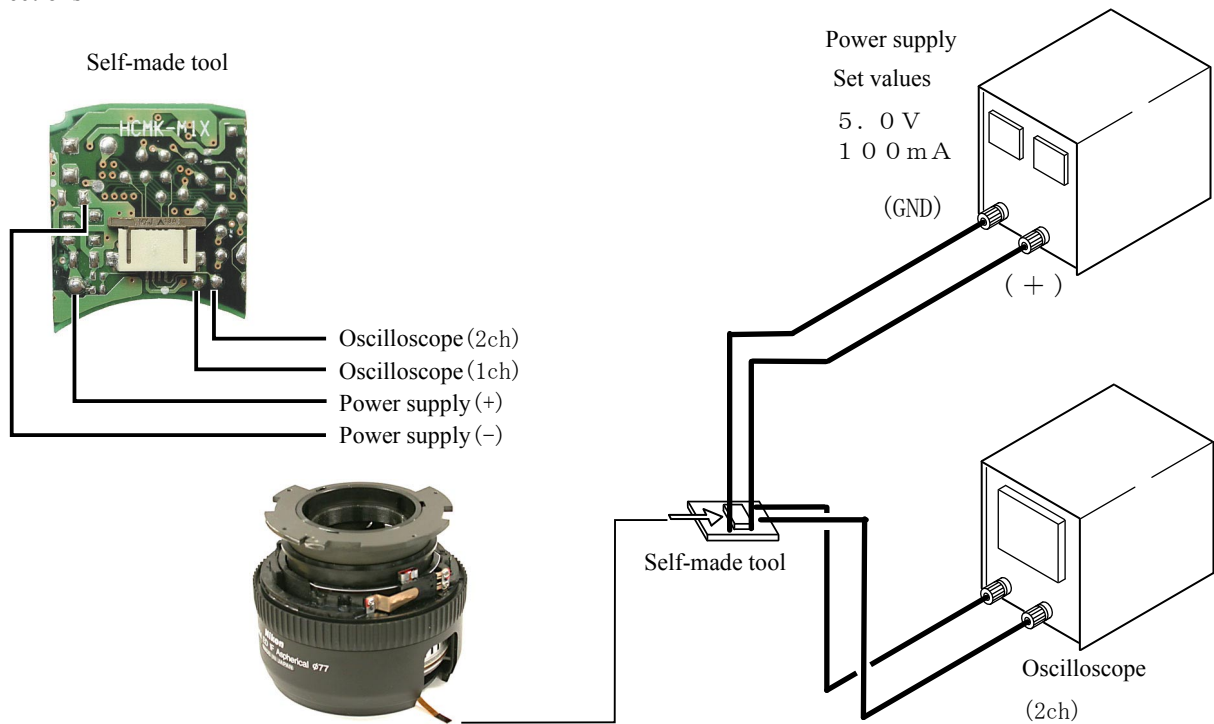

• How to conduct inspection and adjustment

- ① Make sure that the current and voltage of the connected rated voltage power supply are set values.
If they meet the set values, turn on the power.
- ② Set the oscilloscope and drive the focus ring by hand.

Note : Since the shape of waveform varies according to the driving speed of focus ring, particularly and properly set Time/Div.

- ③ In case of detecting any wider waveform noise, use the filter function.
How to set the filter function in the employment case of Yokogawa-manufactured DL1540
 - 1 . Press the filter button.
 - 2 . Select "Smooth" in the menu on the PC screen.

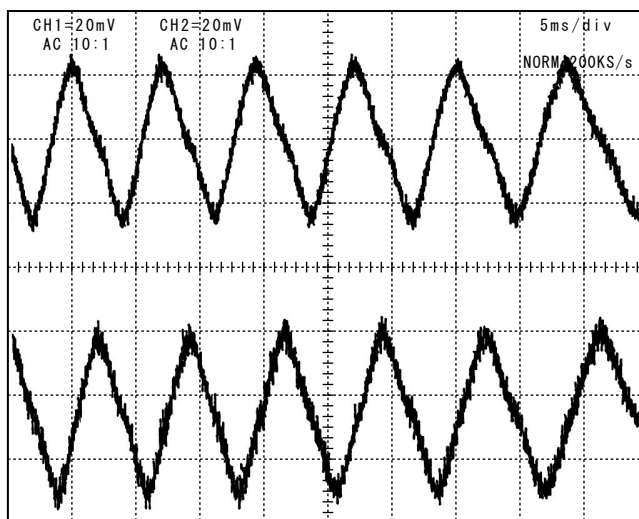

• Oscilloscope setting

V/Div (ch1)	: 20 mV
V/Div (ch2)	: 20 mV
Coupling	: AC
Time/Div	: 5 m Sec
Trigger Mode	: NORMAL
Trigger Coupling	: AC
Trigger Source	: CH1
Trigger Position	: + 4 div
Trigger Type	: EDGE
Trigger Level	: 0 V
INPUT (ch1)	: AC
INPUT (ch2)	: AC

Standard : The amplitude of every pulse/waveform should be 50mV or more.

Note : Check the waveform by letting the focus ring to travel from the infinity-end position to the near distance end position and vice versa.

- ④ In the case of smaller amplitude, for adjustment, loosen the two screws #541 and then shift the MR head position as shown in the right figure.

Note : During adjustment, prevent the magnetic tape and MR head from touching the magnetized driver bit, or the magnetic data may be damaged.

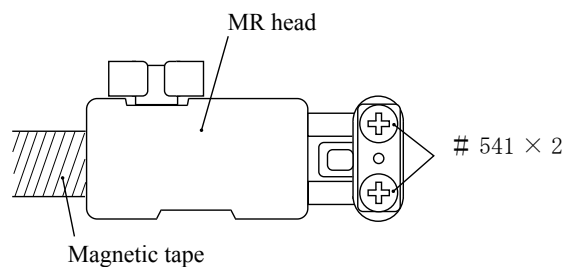

《Reference》

- In case the amplitude of either CH1 or CH2 seems smaller, one of the two screws #541 may be loosened. Then, check the screws. In case the screws are fully tightened, the MR head may be troubled. Then, be sure to replace the MR head unit B15 and adjust it again.

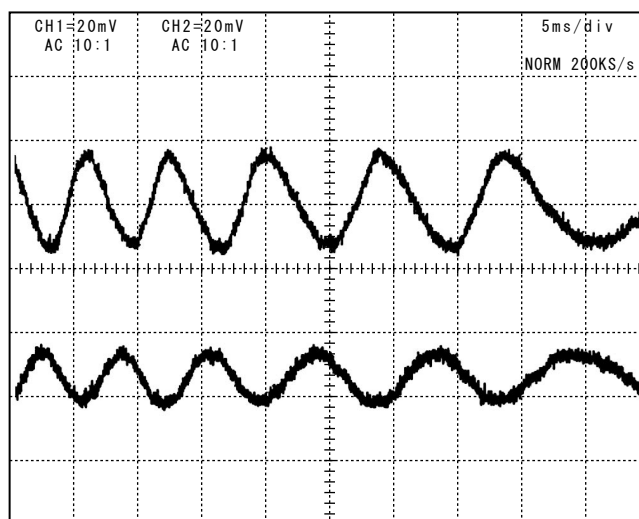

- In case of a presence of partial drop in the amplitude between the infinity and the near distance, the magnetic data in magnetic tape may be damaged. Then, replace the magnetic tape and adjust it again.

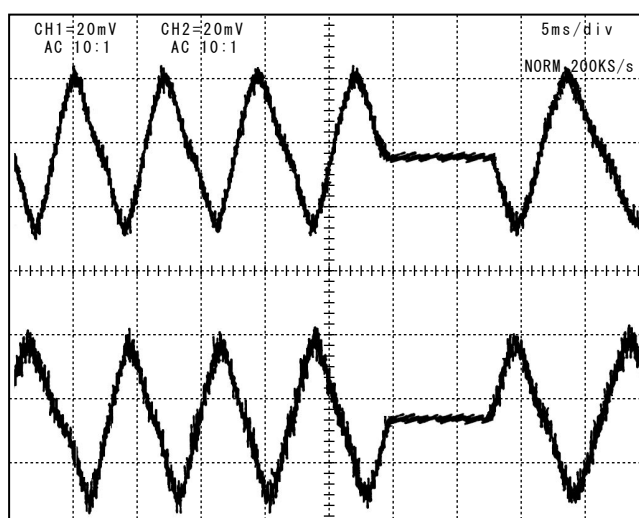

- ⑦ Turn off the rated voltage power supply and remove the SWM unit. P

SWM UNIT

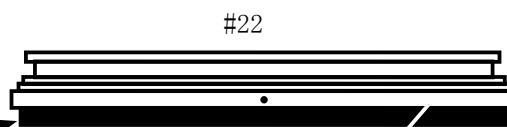
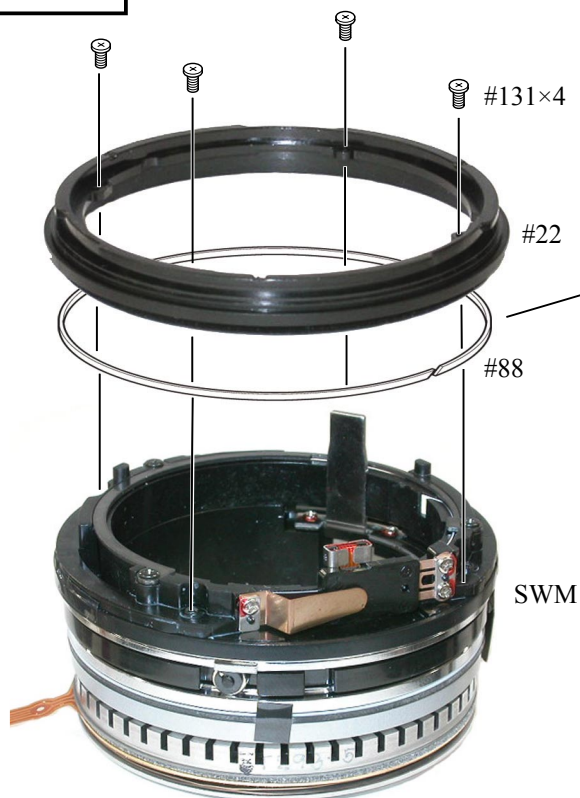

- Attach #88 to #22, and apply the oil barrier to the overall #88.
- Build #22 in the SWM unit.
- Tighten 4 screws (#131) .

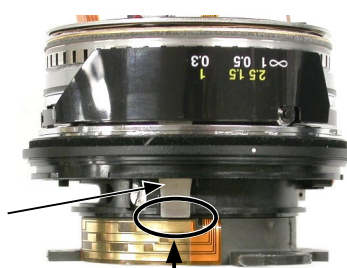
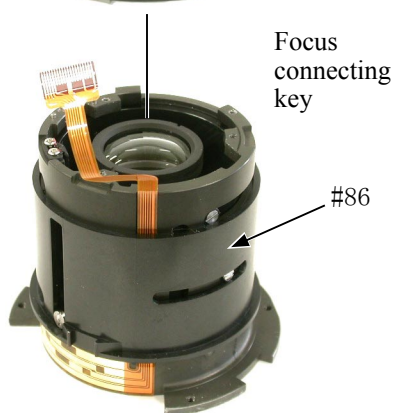
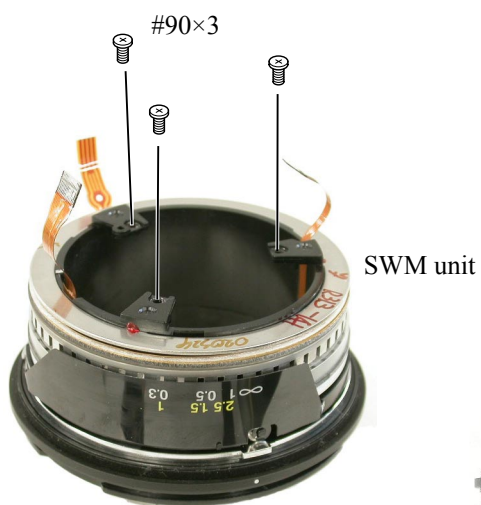

Insert the focus connecting key into the groove of #86.

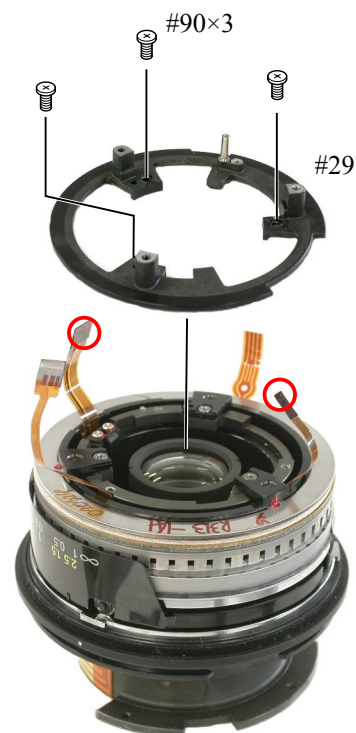

Pass the circled FPC through the inside of #29.

MAIN PCB

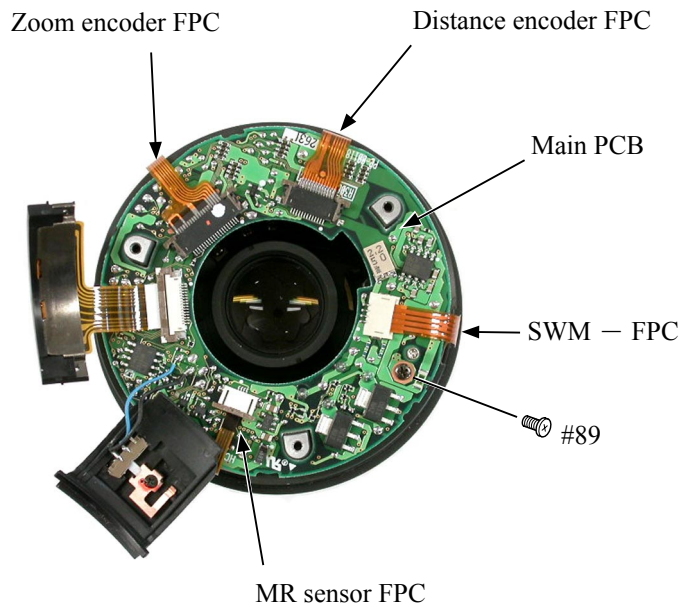

- Attach the main PCB.
- Screw #89.
- Connect the FPC (at 4 parts) to the connector.

INDEX RING, FOCUS RING

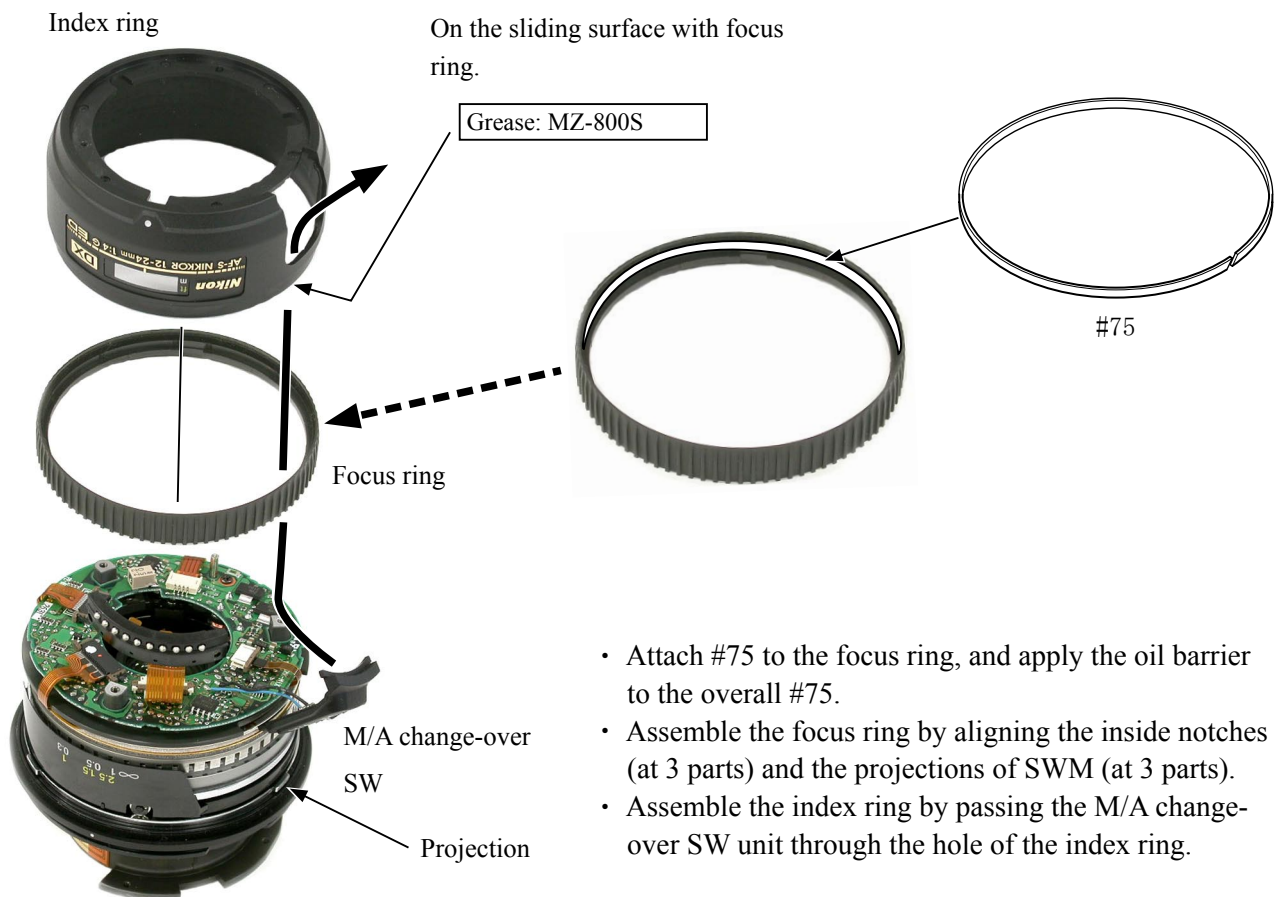

- Attach #75 to the focus ring, and apply the oil barrier to the overall #75.
- Assemble the focus ring by aligning the inside notches (at 3 parts) and the projections of SWM (at 3 parts).
- Assemble the index ring by passing the M/A change-over SW unit through the hole of the index ring.

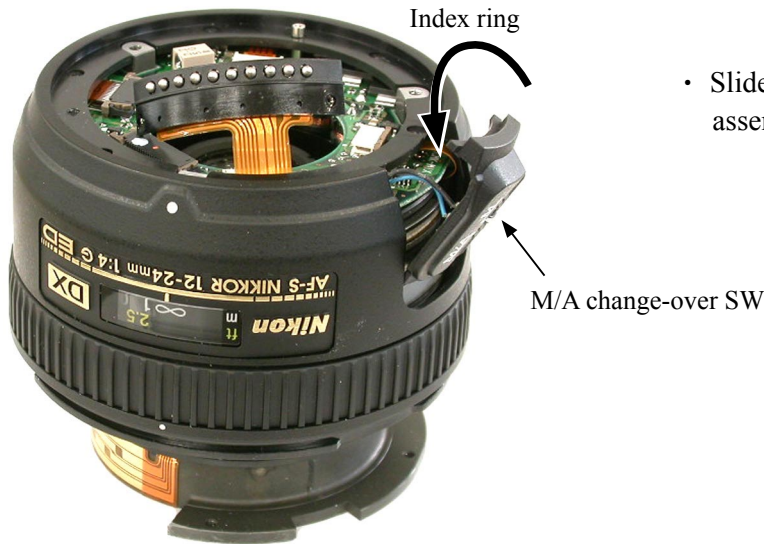

- Slide the M/A change-over SW and assemble into the index ring.

BAYONET

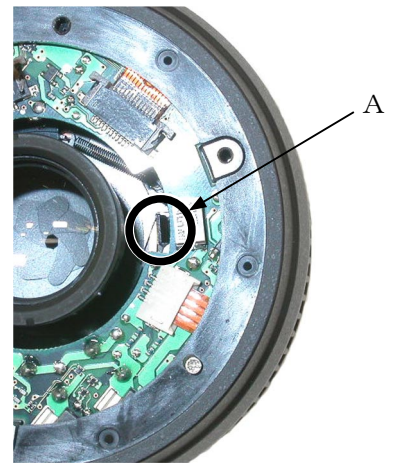
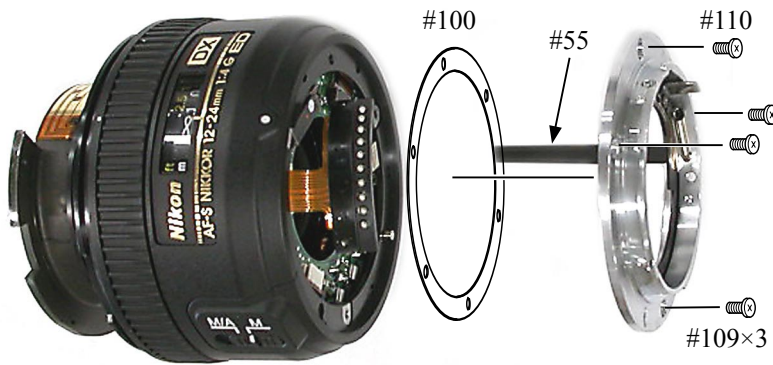

- Put the aperture lever (#55) in A of the above.

POSITION ADJUSTMENT OF APERTURE LEVER



- Turn the zoom to the TELE side. (to the position where the 2nd and 3rd lens units are pushed downward.)
- Attach the tool (J18004-1) and make sure of the aperture diameter.

Standard: Full aperture

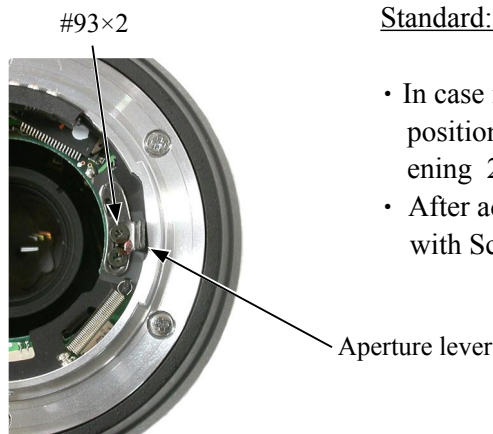

- In case it is out of standard, adjust the position of the aperture lever by loosening 2 screws (#93).
- After adjusting, fix the 2 screws (#93) with Screw Lock.

REAR COVER RING

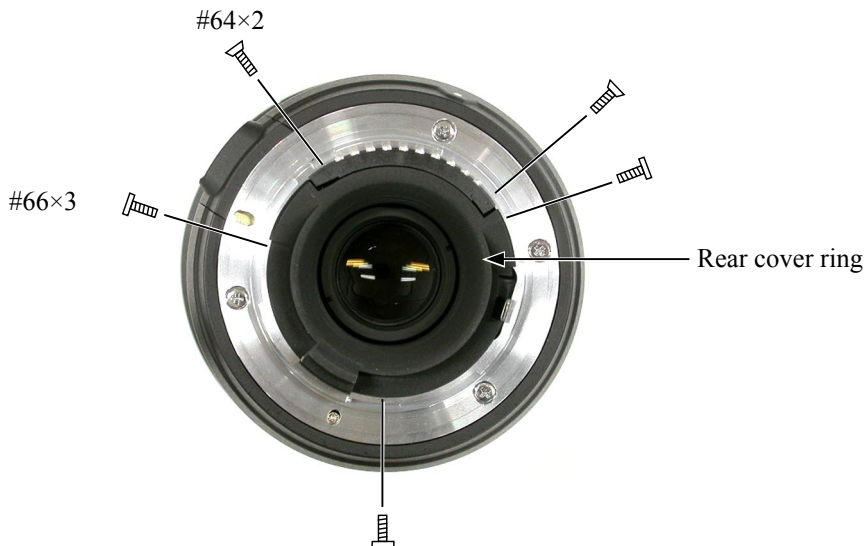

ZOOM RING

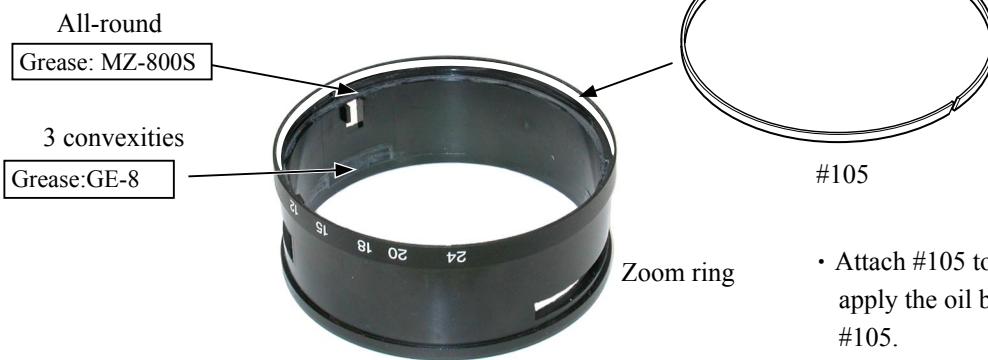

• Attach #105 to the zoom ring, and apply the oil barrier to the overall #105.

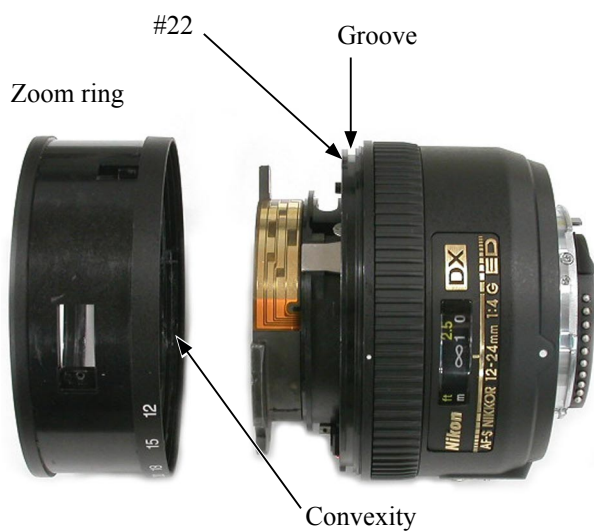

• Put the convexities (at 3 parts) inside the zoom ring in the notches (at 3 parts) of #22, to assemble together.

FILTER RING

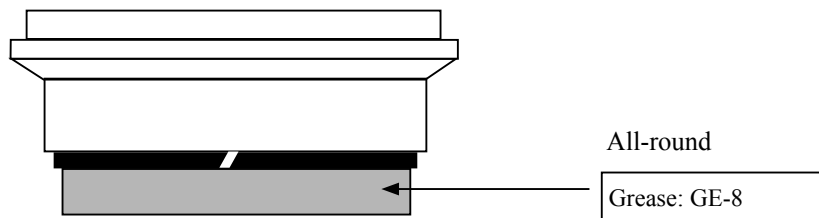

Filter ring



- Put the convexity of the filter ring in the notch of the above, and attach the filter ring with 4 screws (#104).

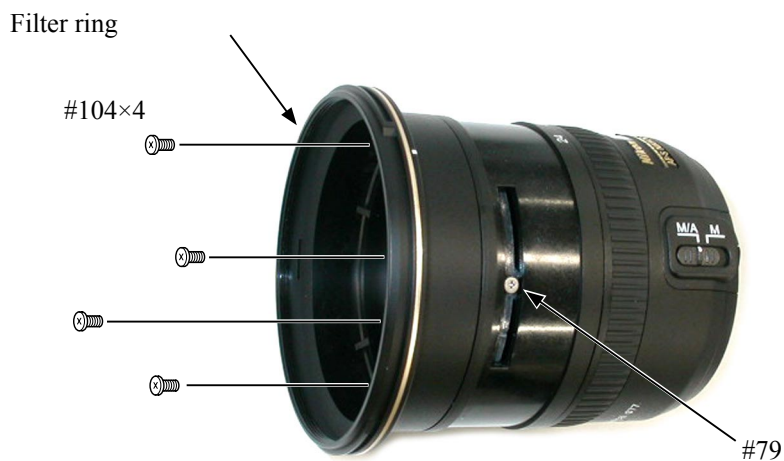

ZOOM ENCODER BRUSH



Position to attach the encoder brush

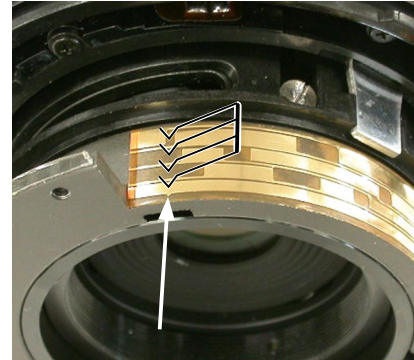

- Turn the zoom to the TELE side.
 - Attach the encoder brush (B4) in the above position and fix it with screw (#66).
- After adjusting, fix #66 with the Screw Lock.

RUBBER RING

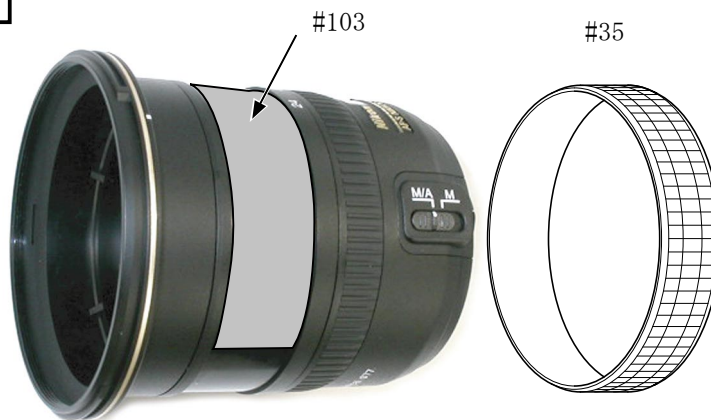

1ST LENS GROUP

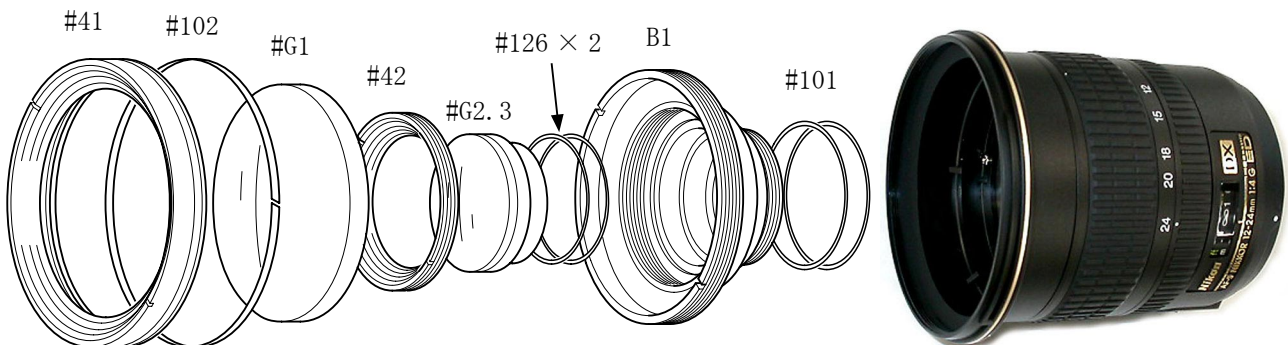

- The size of 2 washers (#126) is fixed (0.038mm).

ADJUSTMENT (DIVISION) OF FOCUS MOVEMENT (T, W)

- 1 . Fit the infinity (∞) mark of the focus ring to the index.
- 2 . Fix the aperture lever to make the aperture "full".
- 3 . Read the values of the Wide and Tele sides.
- 4 . Carry out the following calculations.

$$A - B = C$$

A = Value of Tele side

B = Value of Wide side

C = Adjustment amount (mm) of the 2nd lens group unit washer #101

- 5 . Adjust the thickness of the washer #101 by the value of C calculated in the above. If C is positive, thicken the washer. If it is negative, thin the washer.

Note : When setting the washer #101, put a thin washer between thick washers.

ADJUSTMENT OF BACK FOCUS

- 1 . Fit the infinity (∞) mark of the focus ring to the index.
- 2 . Fix the aperture lever to make the aperture "full".
- 3 . Read the value of Wide or Tele side.
- 4 . Remove the bayonet mount.
- 5 . Adjust the thickness of the washer #100 by the difference from the standard value. If the difference value is positive, thicken the washer. If it is negative, thin the washer.

Focal length (f)	Standard (mm)
1 2 mm	- 0 . 0 5 ~ + 0 . 1 0
1 8 mm	- 0 . 0 5 ~ + 0 . 1 0
2 4 mm	- 0 . 0 5 ~ + 0 . 1 0

Lens alignment

Note: This adjustment is required when the 3rd lens groups is removed.

(1) Preparation of Lens to be examined

- Remove the main PCB on Page L2-L4.
- Remove the aperture lever of the bayonet mount.
- Remove the solder of wires (blue and black) of M/A change SW from the main PCB.
- Assemble the other parts, but exclude the main PCB, aperture lever, and rear cover ring.
- Create an aperture opening tool for (AF-S DX12-24/4G).

Procedure

- ① Prepare one piece of rubber (17mm x 7.5mm x 2mm).

(Note) Choose relatively flexible material of rubber that can be easily cut, because it is used for putting in the clearance between the lens aperture lever and lens chamber.

- ② Cut the rubber sheet (17mm x 7.5mm x 2mm) into the below size.

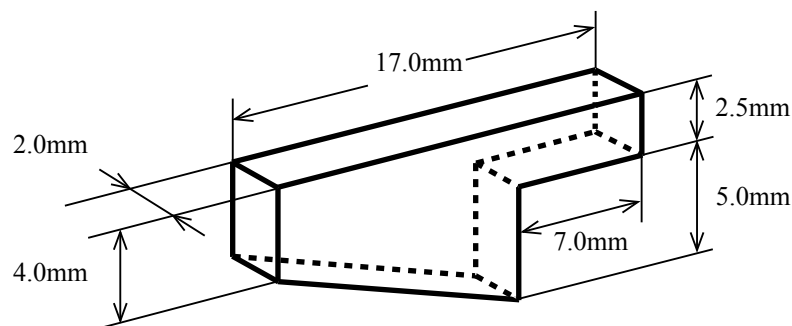

- By using the above created tool, set the lens to full aperture opening.

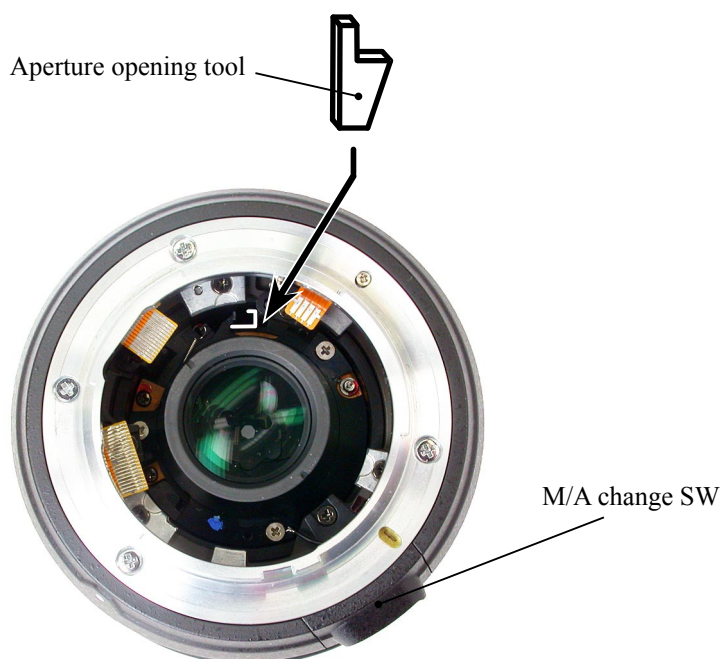

(2) Preparation of Lens optical alignment equipment

- Fix the attachment holder for the 3rd lens group (J19127J) in the lens equipment for center alignment.

How to fix: Move down the holder-moving lever slowly so that the holder touches the stage. Then tighten 4 screws to fix it.

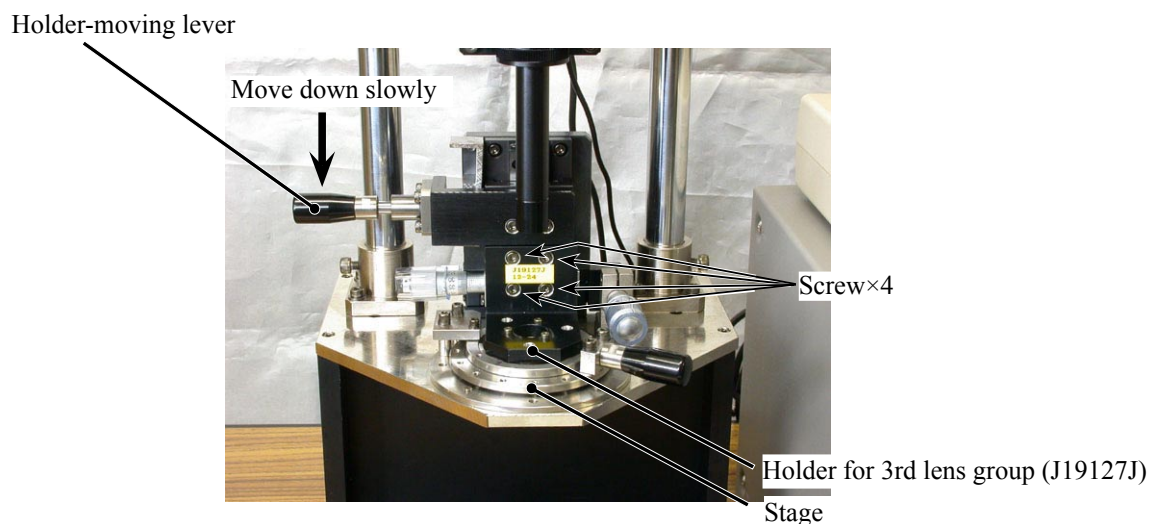

- Create the center positioning tool (ref. Page L23-13 for how to create it).
- Create setting boards in which "Lens alignment chart" and "Viewers" are fit. (ref. Page L23-15 for how to create them.)

Lens optical alignment equipment for center (left) and periphery (right)

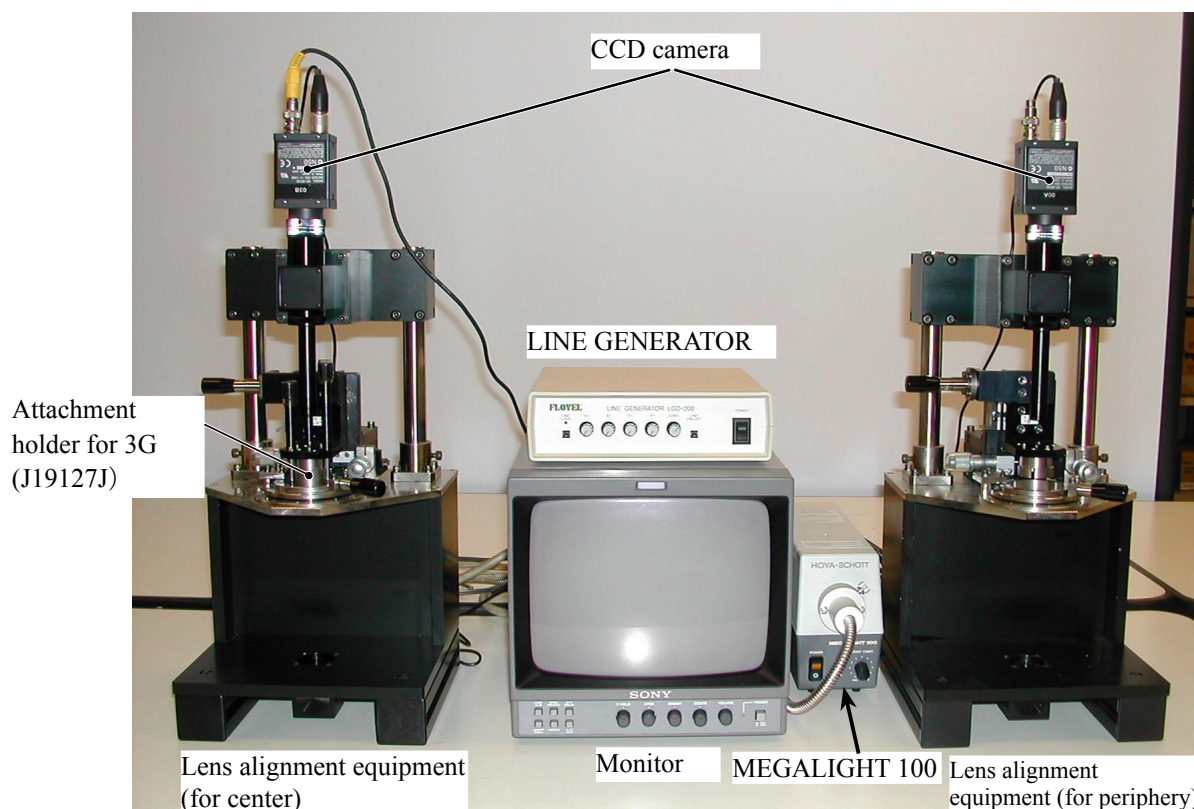

Back view of Lens optical alignment equipment for center and periphery

- Connect each cable to the appropriate equipment with the same number. (e.g. Connect up ① to ①.)

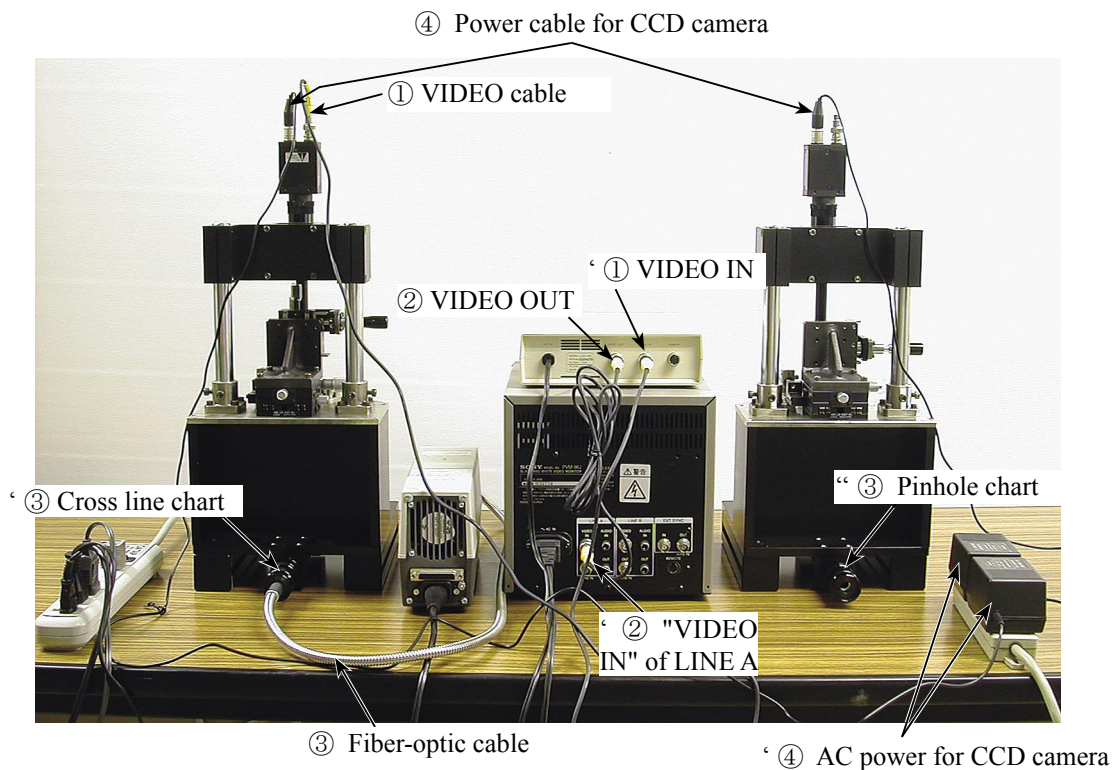
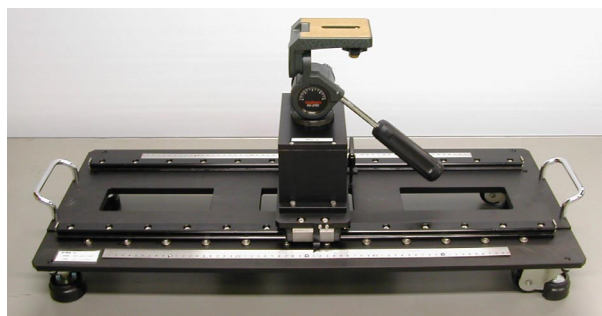

Chart shooting equipment for Lens alignment



Slide rail for Lens alignment equipment



The chart is embedded in blackened cardboards.



(3) 3rd lens group temporary alignment

- ① Mount the (self-made) center positioning tool on the lens alignment equipment (for periphery) by setting the groove in place slightly to the left (in a counterclockwise direction) from the below 12 o'clock position . Then turn the tool clockwise all the way to the right, and move the fixing-lever to the left to fix it.

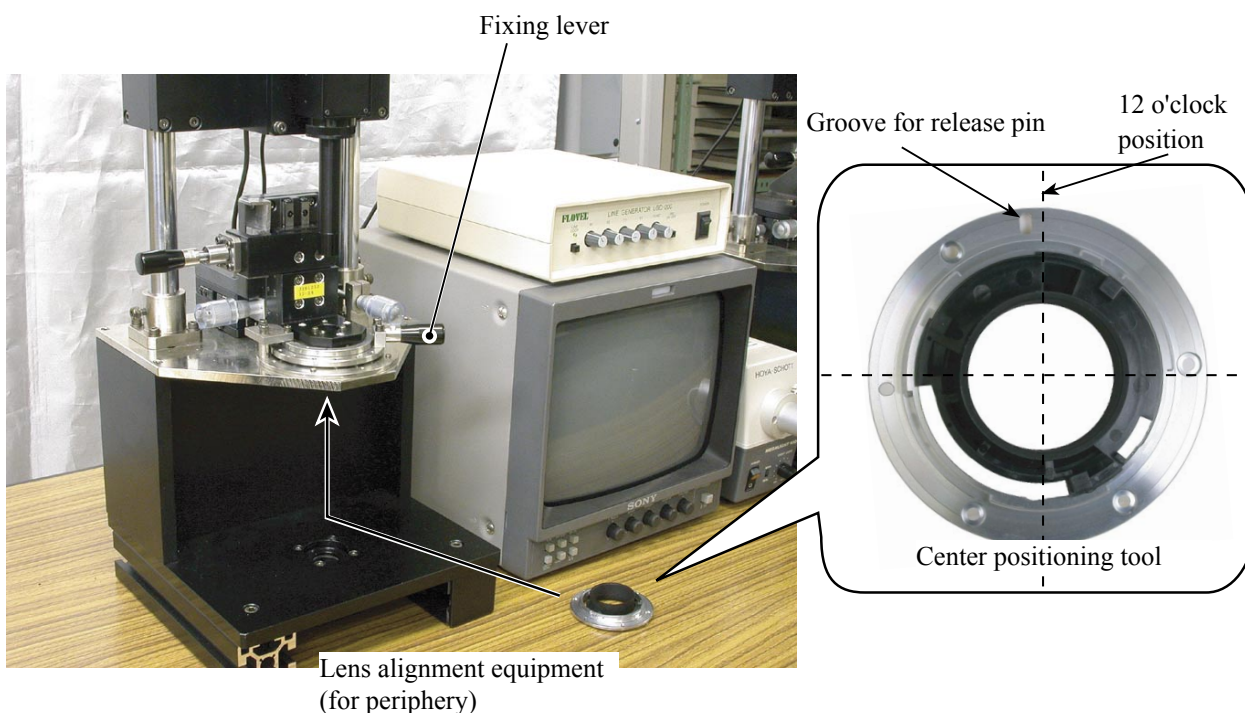

- ② Unlock the holder-moving lever, and move the holder down slowly by the lever.

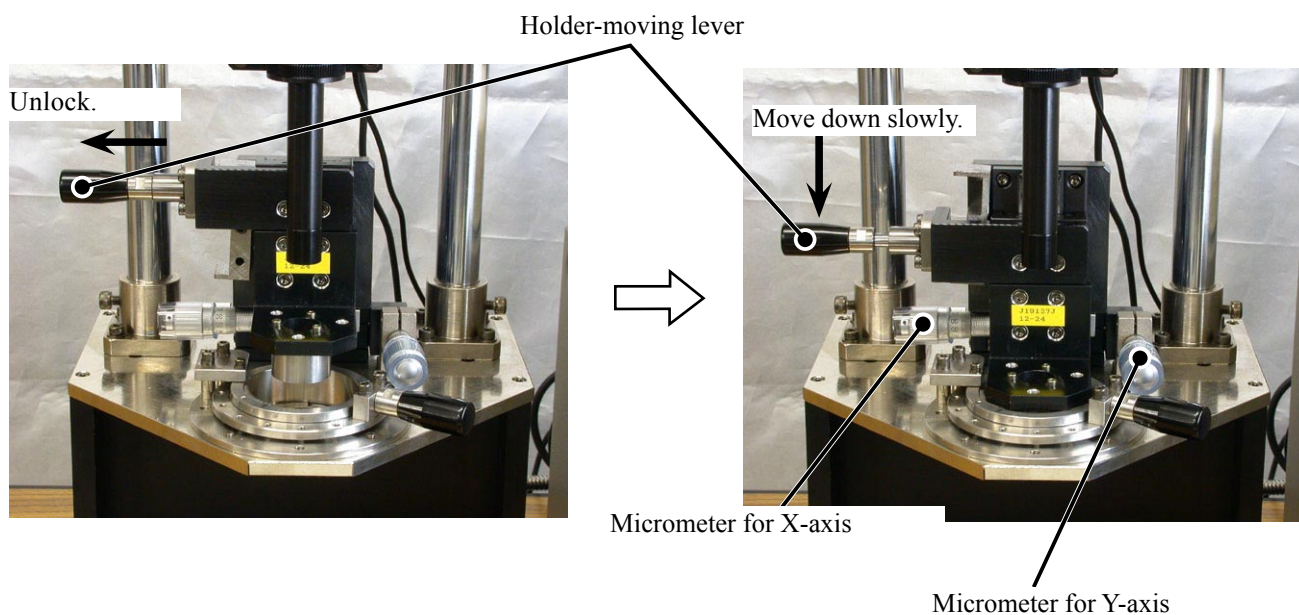

- ③ Adjust the holder's position by rotating the micrometers for X-axis or Y-axis so that the holder does not touch the protection ring of the center positioning tool.
- ④ Move the fixing lever of the alignment equipment to the right, and remove the center positioning tool from the equipment.



(4) 3rd lens group alignment (Center alignment)

- ① Set the zoom ring by turning it all the way to TELE-end (24 mm), and loosen the one screw of the 3rd lens-group chamber.

(If the lens to be examined remains to be set in the equipment, the alignment screwdriver touches the side surface, resulting in a failure of turning the screw.)

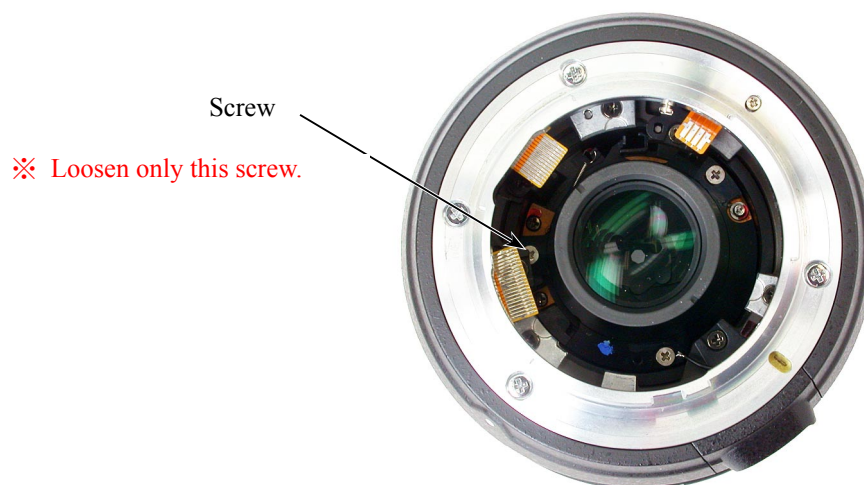

- ② Set the 2 alignment screwdrivers (long and middle) to the equipment (for center). Then move the holder-moving lever up to lock the holder. (ref. L23-7)
- ③ Mount the lens on the equipment (for center) (ref. ① of (3) for how to fit in it.), and set the zoom ring to TELE-end (24-mm).
- ④ Set the both cable (which connects the VIDEO terminal of the CCD camera) and the fiber-optic cable (which connects MEGALIGHT 100) to the equipment (for center).

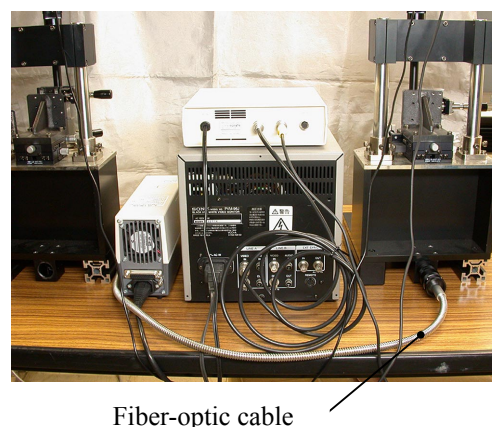
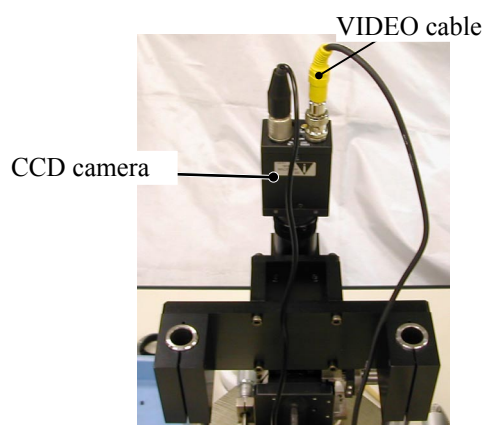

- ⑤ Turn the "LIGHT CONT." knob of MEGALIGHT 100 to adjust brightness, and turn the focus ring to adjust the shape of the pinhole on the monitor. (ref. Pic.1 for the image of the pinhole.)



Pic.1

LIGHT CONT.knob

- ⑥ Check the pinhole shape on the monitor. In case of Fig.1-A, set the zoom ring to WIDE-side (12 mm) and check the shape. If the shape is still like Fig.1-A even at WIDE-side, remove the lens from the equipment (for center) and go to the next ⑩. In case of Fig.1-B or C, go to the next ⑦.

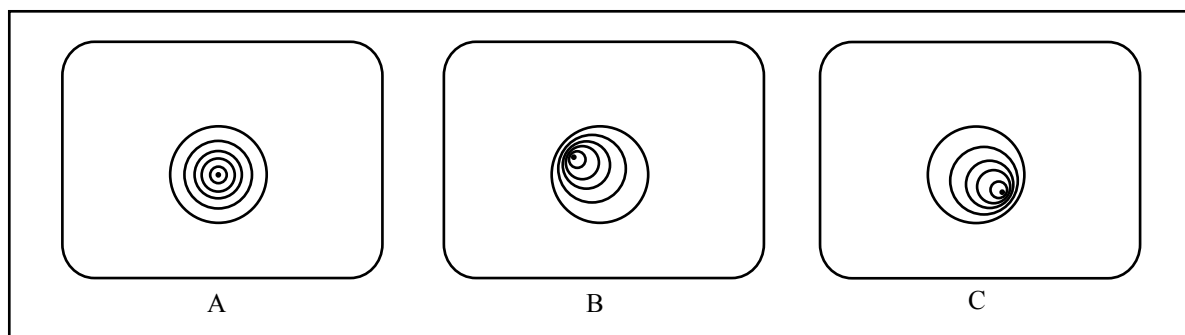
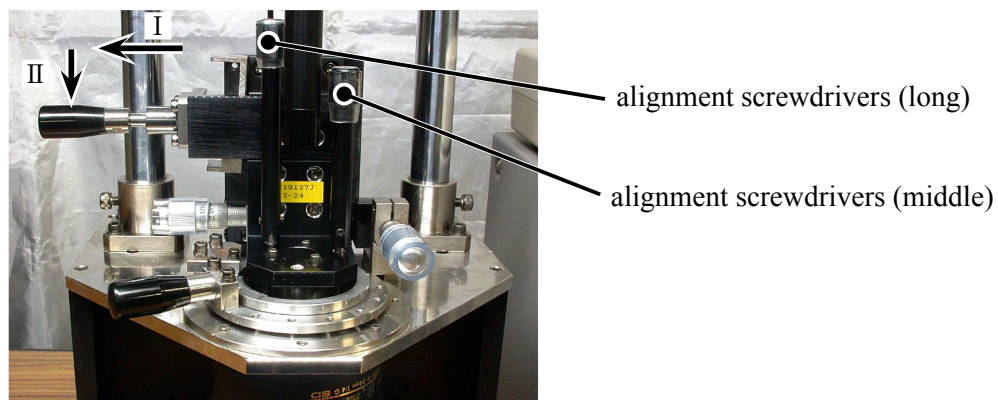

Fig.1

- ⑦ Unlock the holder-moving lever, and move the holder down slowly by the lever. Loosen the 2 screws of the 3rd lens chamber with alignment screwdrivers (long and middle).



- ⑧ Adjust the micrometers (X and Y) by turning them so that the shape on the monitor becomes like Fig.1-A.
 Note) When the holder is raised, the image on the monitor is changed in its shape. So make an adjustment by considering this change.



- ⑨ When the monitor image becomes like Fig.1-A, tighten the 2 screws of the 3rd lens chamber. Move the holder-moving lever up slowly to lock the holder, and remove the lens from the equipment (for center).
- ⑩ Set the zoom ring by turning it all the way to TELE-end (24 mm), and tighten the one screw of the 3rd lens-group chamber.

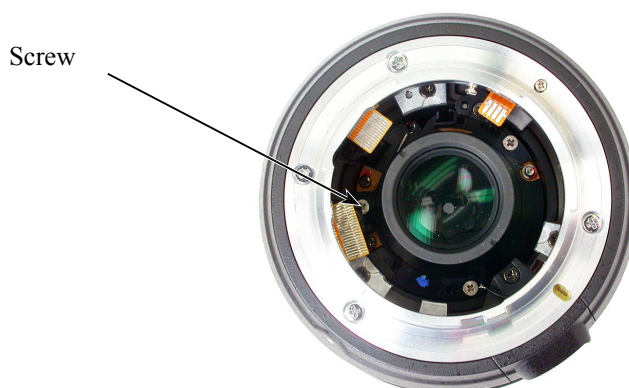

(5) Chart shooting for the 3rd lens-group alignment

- ① Prepare a camera (D100). Set the shutter speed to “M1/80” and the focus mode to “M”. On the shooting menu, set the Image Quality mode to “RAW”, the WB to “Preset” and the ISO to “200”.
- ② Set up the camera (D100) on a tripod on the slide rail. Set the indication pointer of the tripod to 30 cm.

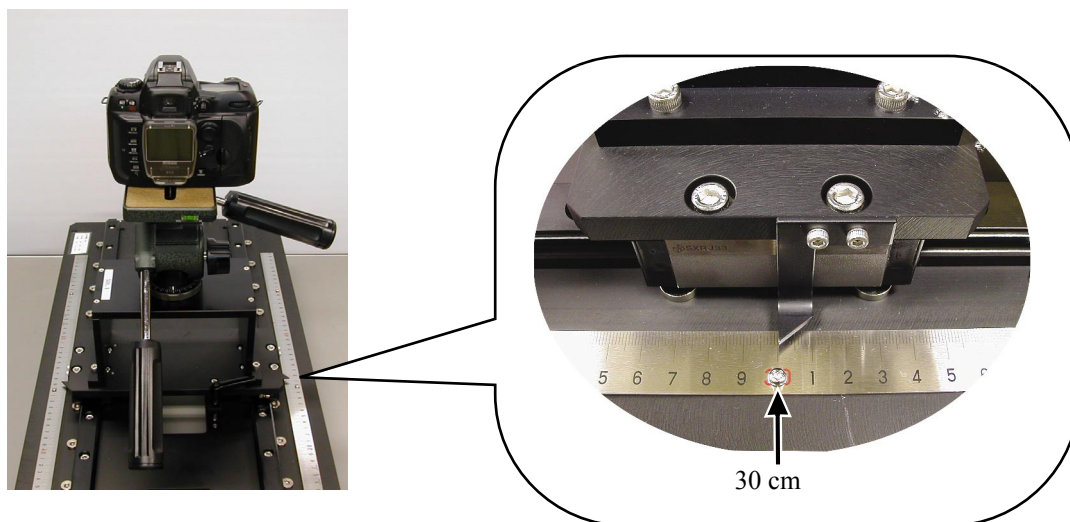

- ③ Set the alignment chart (J19128) as shown below.

Shooting: 40-fold magnification

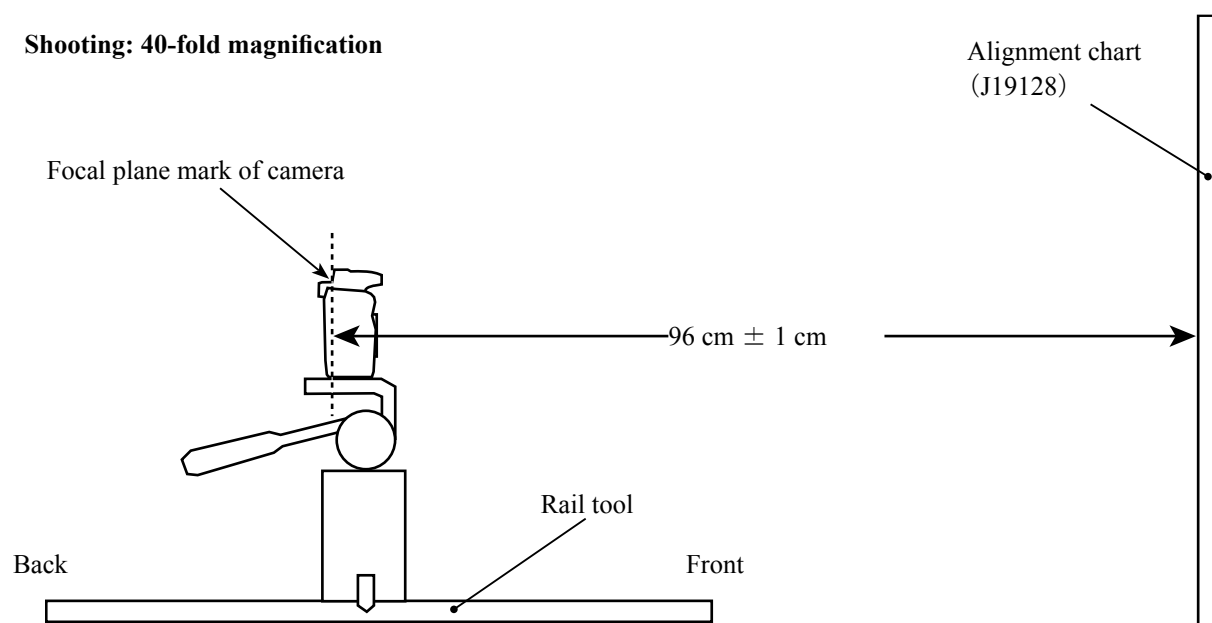

- ④ Turn the power of viewers (5 pcs.) to ON.

(Note: If the batteries of viewers are exhausted with decreased brightness, the shooting data cannot be obtained correctly.)

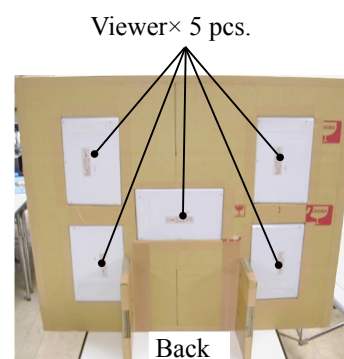
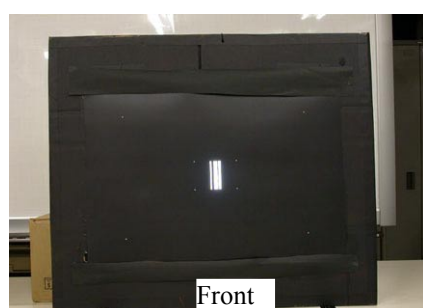

- ⑤ Fit the lens to be examined in the camera. Set the zoom to TELE-end (24 mm).
- ⑥ By looking through the viewfinder, adjust the height and tilt based on the 4 point sources of light of the center.
- ⑦ Adjust the tilt of the slide rail to make the 3 chart lines position in the center of the viewfinder, when the tripod is slid all the way to the front and back.

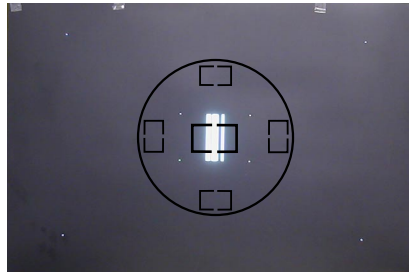

- ⑧ Connect the PC and camera via USB cable. (Camera setting: Mass Storage)
- ⑨ Start the adjustment software (LWM.exe).
- ⑩ "Lens select" window opens. Select "AFS DX 12-24/4G[IF]" and click "OK".
- ⑪ Click the "Reset all log" button.

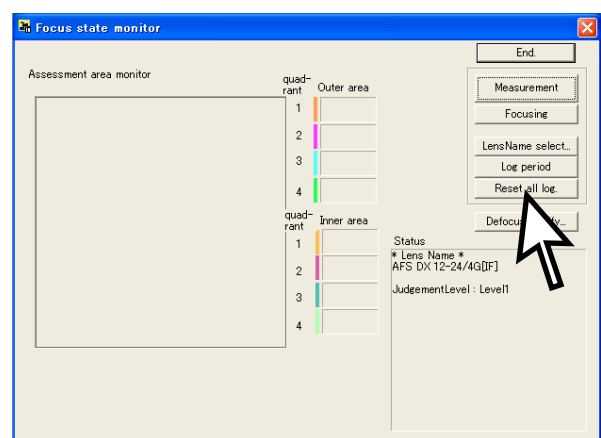
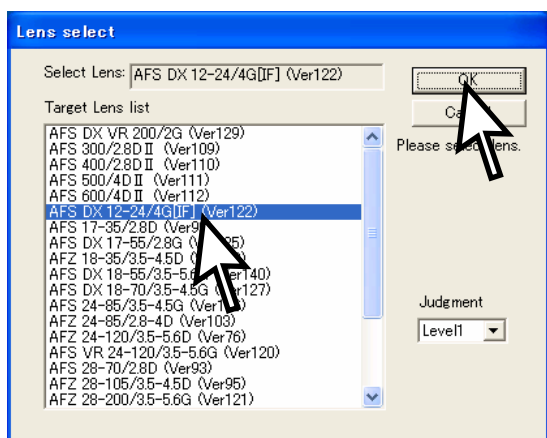

- ⑫ Confirm that the indication pointer of the tripod is set to 30 cm.



- ⑬ Looking through the viewfinder, turn the focus ring of the lens slowly from close-side to infinity-side. Stop turning it at the position where the in-focus indicator is switched from blinking to lighting.
- ⑭ Slide the tripod to the front by 18 ± 0.1 cm.
- ⑮ Turn off the lights adjacent to the alignment chart.
- ⑯ Click the "measurement" button of the adjustment software.
- ⑰ When the shutter is released, slide the tripod to the back by 6 ± 0.1 cm and make a remeasurement.

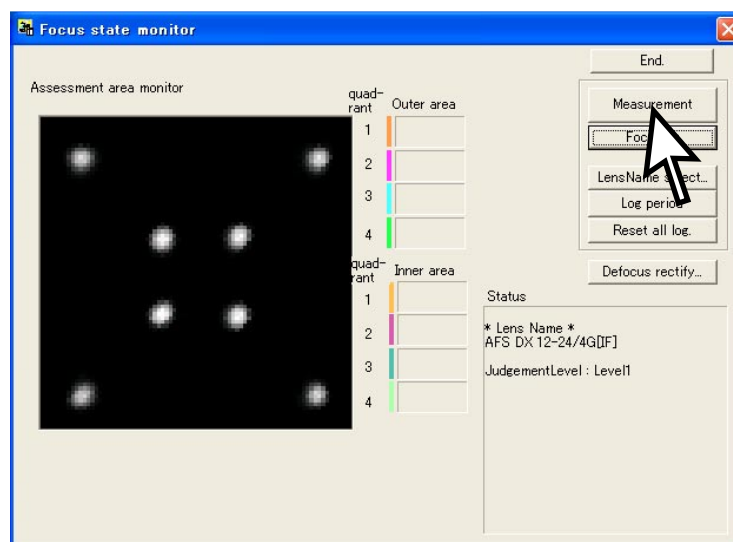
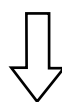
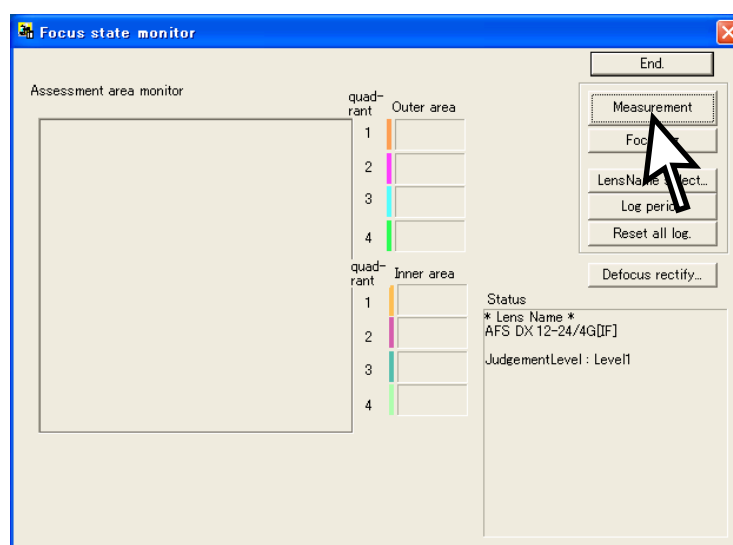

⑱ Again, slide the tripod to the back by 6 ± 0.1 cm and make a remeasurement.

Repeat this operation 4 more times, totalling in 7 measurements. (The total sliding distance is 36 cm.)

Note 1: When the below warning is given, there may be some defects in the brightness of the viewers and/or parallelism of the chart and camera, etc. So correct the above and make a remeasurement.

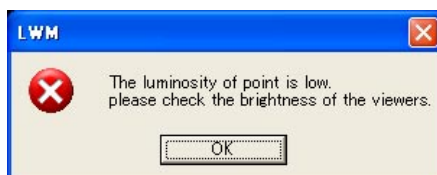

Note 2: When the below warning is given, recheck that the Quality mode of the camera is set to RAW.



Note 3: When the below warning is given, recheck that the zoom ring of the lens is set to TELE-end.



- ⑱ After the 7 measurements, point the cursor to the confirmation screen of the software. Click it 3 times, and if "END" is displayed on the Result, the lens optical alignment is completed.
If "END" is NOT displayed, go to "(4) 3rd lens group alignment (center alignment)", and make readjustment.
- ⑳ To reassemble all the parts of the lens, reverse the disassembly procedure (referring to Page L18-L20).

Confirmation screen

Result



How to create positioning tool of Rear lens-group holder for lens alignment
(It is the same tool with AF-S ED 24-85/3.5-4.5G)

1: Summary

1-1: This is a positioning tool of the rear lens group holder for lens alignment, in order to secure the position for attaching the rear lens group temporarily.

2: Preparation

2-1: The following is used:

- * Rear cover ring (JAA78451- Part no. :1K631-423) X 1 pc.
- * Bayonet mount (JAA78071- Part no.: 1K404-157) X 1 pc.
- * Mount rotation stopper screw (JAA78071- Part no.: 1K120-012) X 1 pc.

3-1: Put the bayonet mount as shown in Fig. 1.

Put with the groove, in which the lock pin of camera body enters, just upward.



Fig. 1

3-2: Mount the reversed rear cover ring on the position of Fig. 1, and attach them as shown in Fig. 2.

Put with the groove, in which the lock pin of camera body enters, just upward.

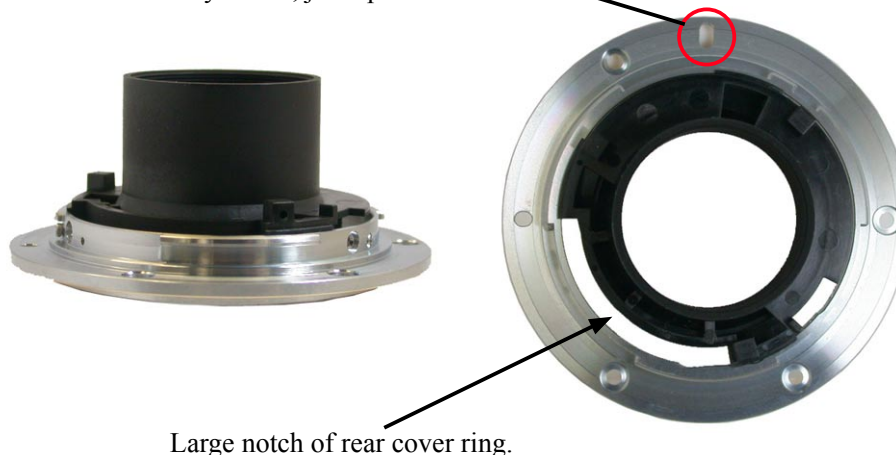

Fig. 2

3-3: Turn the rear cover ring clockwise, which was attached to the bayonet mount. Then stop at the position as shown in Fig.3-1.

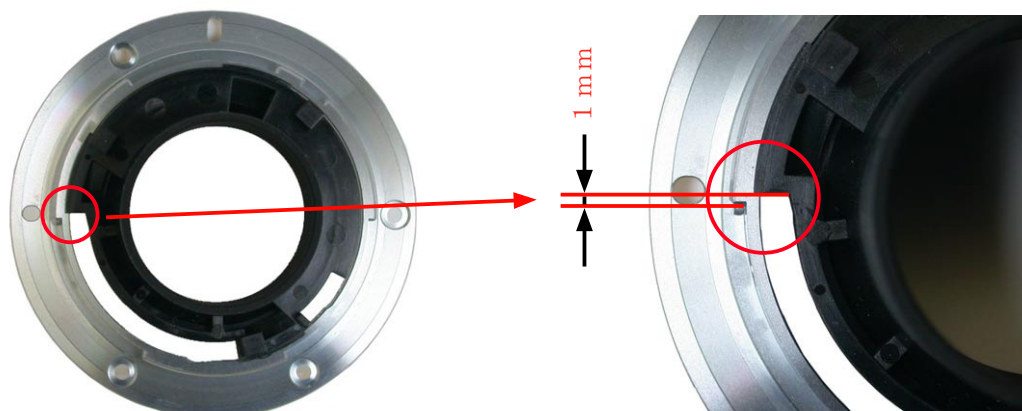

Fig. 3

Fig. 3-1

3-4: Fix the following 3 locations of the rear cover ring with the instant glue.

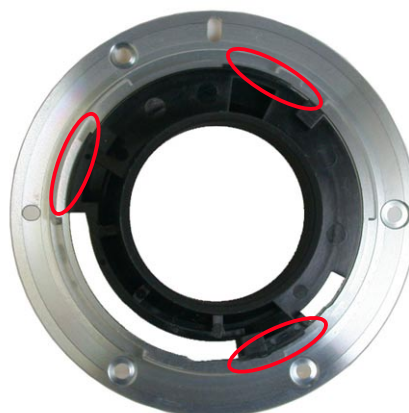
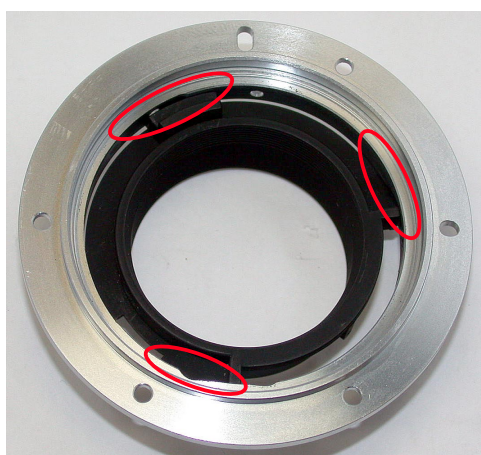

Fig. 4

3-5: Turn the bayonet mount over. Reinforce the following 3 locations with the adhesive to attach the bayonet mount and rear cover ring firmly.



3-6: Attach the mount rotation stopper screw at the appropriate position.



How to create Setting board of "Lens alignment chart" and "Viewer"

1. Summary

1-1: In order to get necessary data for lens alignment, this board is created to use for setting a special chart and light viewers (for chart illumination), while taking pictures of the special chart with a digital camera.

2. Preparation

2-1: Prepare a board (760 x 880 x 20 mm) or 2 package cardboard boxes (size 2.33).

(Note) Because you have to cut out the shape to embed light viewers, choose package cardboard boxes (size 2.33) or material which can be easily cut. — ref. Fig. 1

3. Procedure (In this document, 2 package cardboards are used)

3-1: As for the 1st flattened cardboard box (size 2.33), check the positions for embedding the light viewers, and cut out the shape at 5 locations (shaded parts/size 154 x 245 mm) as shown below. — ref. Fig. 2

(Note) Cutting the shape slightly smaller than the actual size of viewers makes it easier to fit the positions of viewers tightly.

3-2: Put the 2nd flattened cardboard box (size 2.33) and the above cut-out 1st cardboard together as one, and fix them by taping at 4 sides. — ref. Fig. 3

3-3: Then as for the 2nd flattened cardboard box, cut out the shape again by matching the cut-out size of 3-1 for each viewer. — ref. Fig. 4

3-4: Reinforce the edges of cut-out parts with tape.

(Note) To prevent viewers falling off, secure them with tape around the edges. — ref. Fig. 5

3.5: **Blacken around the setting board (with black spray, etc).**

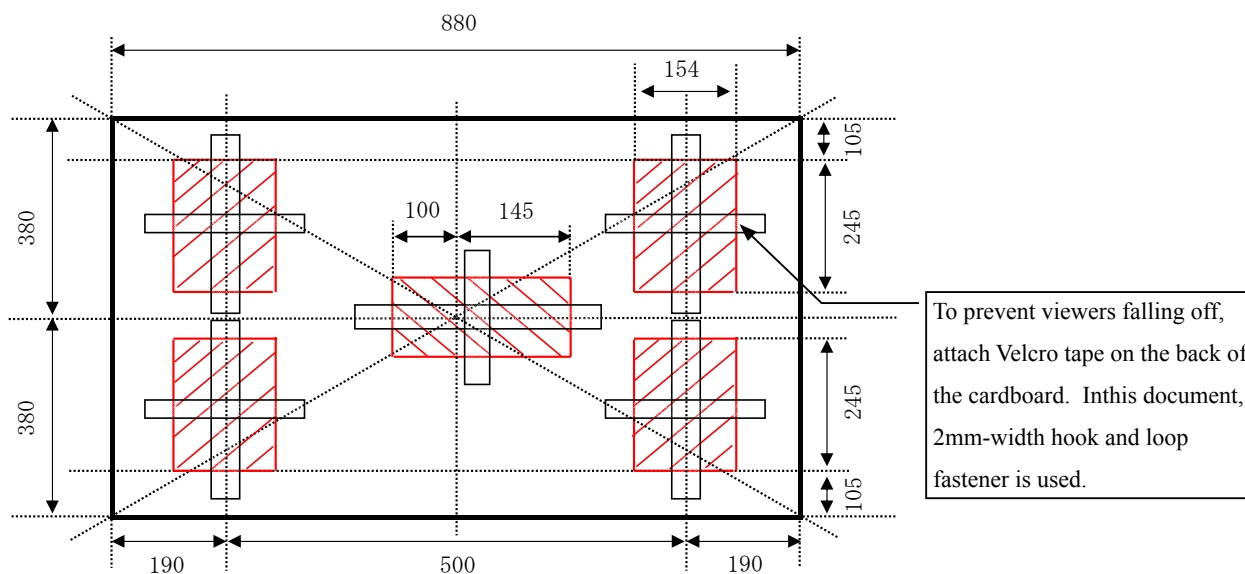

4. Prevent Viewers from falling off (In this document, 2-mm width Velcro tape is used.)

4-1: As shown above, when viewers are embedded, secure them with square pieces of Velcro tape (hook and loop fastener) on the back of the cardboard to prevent viewers falling off.



(Fig. 1- Prepare 2 package cardboard boxes, and flatten them as below.)



(Fig. 2 - As for the 1st flattened cardboard box, cut out the <154 x 245 mm sized> shape at 5 locations.)

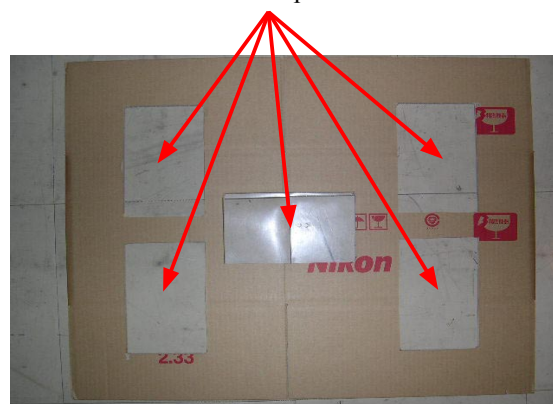

(Fig. 3- Package cardboard boxes)

Put the 2nd flattened cardboard boxe and the 1st cut-out cardboard together as one as shown below.

Fix them by taping at 4 sides.

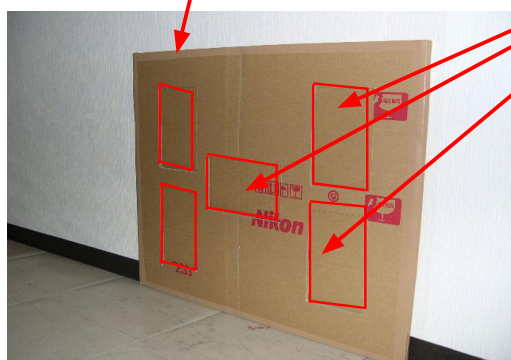

(Fig. 4- As for the 2nd flattened cardboard box, cut out the shape in the same way as Fig.2. Allcardboards are cut out as below.

Cut out by matching the size of the 1st cutting.

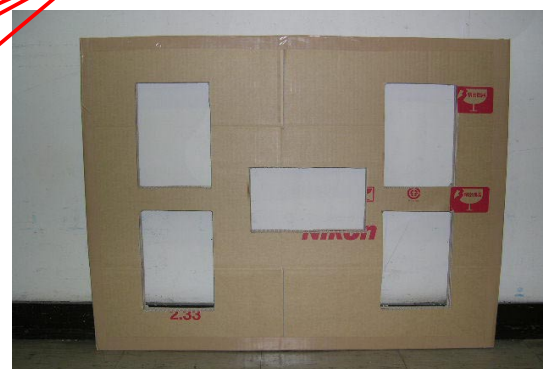

(Fig. 5- Light viewers are embedded.)



To prevent viewers falling off, secure the viewers with tape around the sdges.

(Fig. 6- Setting board is blackened with the chart being attached.)



PREPARATION FOR INSPECTION AND ADJUSTMENT OF MAIN PCB

- In case of replacing the main PCB, SWM unit or MR encoder unit, be sure to adjust the following items due to a necessity on the operation.

1 . Items to adjust

- Adjustment of MR duty
- Adjustment of driving frequency and motor control

2 . Equipment and tools to be required

- Single output rated voltage power supply: 1 unit
For contact A to mount: Output of the DC/DC converter (5.5V 100mA)
For contact F to contact G: 6.0V 3.0A
- Oscilloscope: 1 unit for adjusting the MR duty/adjusting the driving frequency and motor control
- AF-I communication box (J15306 or J15306-1): 1 unit
- AF-I communication adapter (J15307): 1 unit

【System configuration diagram】

By using the DC/DC converter, 1 unit of rated voltage power supply can energize this system fully.
 The following figure shows the system using the DC/DC converter for F100. The system will be explained hereafter on the assumption that this modification has been done.
 In J15306-1 of AF-I communication box, the DC/DC converter is already built in.

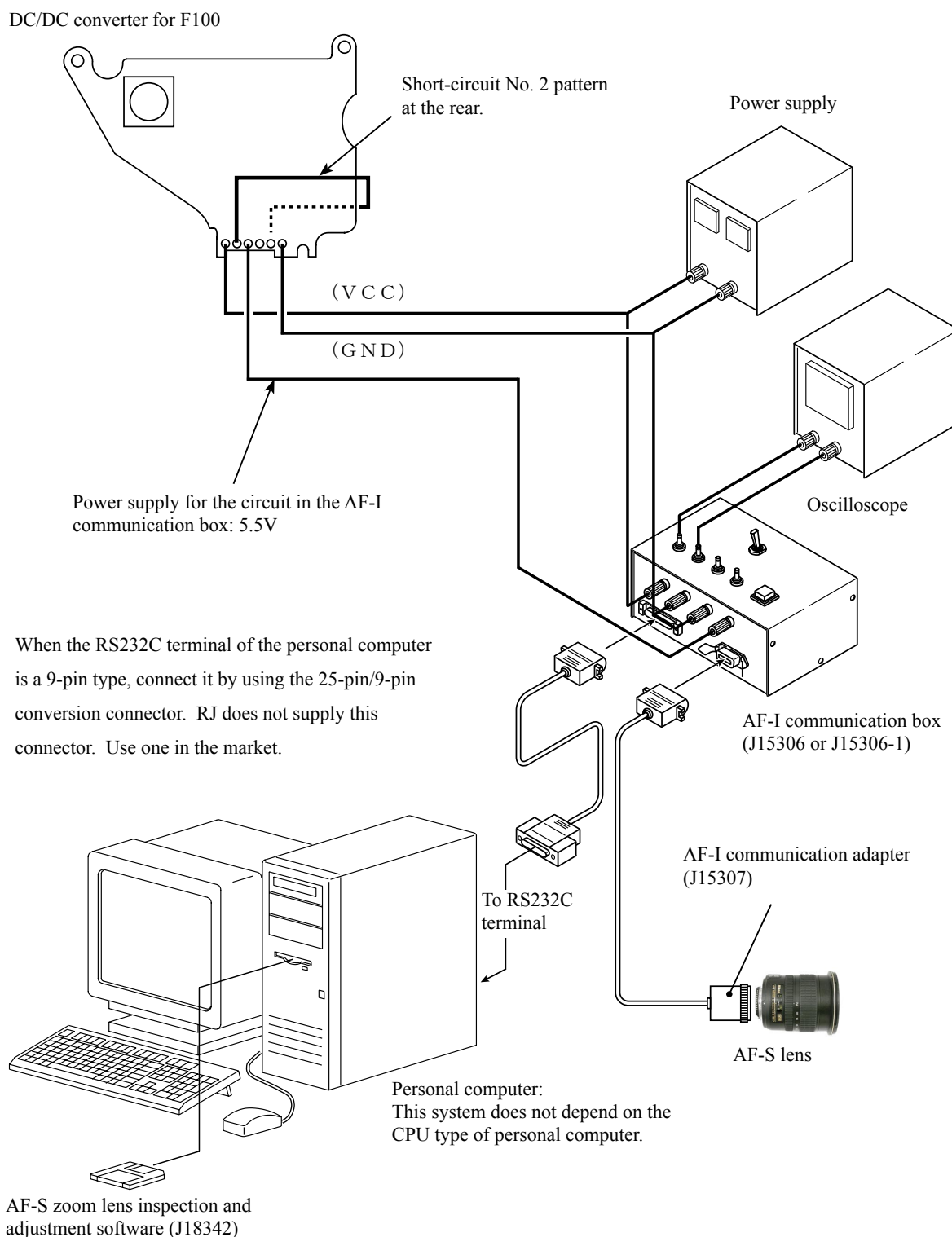

ADJUSTMENT FOR MR DUTY

- In case of replacing the main PCB, SWM unit or MR encoder unit, be sure to make this adjustment.

How to adjust

- ① Make sure that the current and voltage of the connected rated voltage power supply are the set values.
Then, turn on the rated voltage power supply for the contacts A and F.
- ② Select "1. MR DUTY ADJUSTMENT" in the menu items of the AF-S zoom lens (New) inspection program.
- ③ The display to check whether the fixed values are written in EEPROM or not appears. Select a proper item.
- ④ According to the instruction on the screen, rotate the MF ring from the infinity direction to the near distance direction slowly by hand. Make sure that the waveform on the oscilloscope has duty 50% and then stop the MF ring at the near distance end.

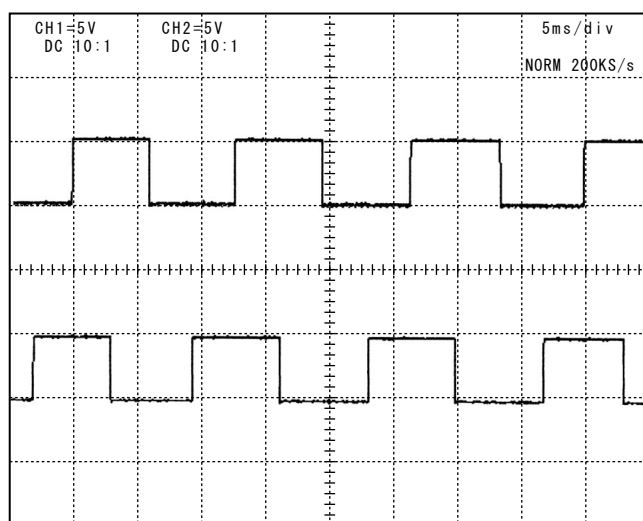

●Setting of oscilloscope

V/Div (CH1)	: 5 V
V/Div (CH2)	: 5 V
Coupling	: D C
Time/Div	: 5 m Sec
Trigger Mode	: N O R M A L
Trigger Coupling	: D C
Trigger Source	: C H 1
Trigger Position	: + 4 div
Trigger Type	: E D G E
Trigger Level	: 2 . 5 V

- ⑤ According to the instruction on the screen, rotate the MF ring from the near distance direction to the infinity direction slowly by hand. Make sure that the waveform on the oscilloscope has duty 50% and then stop the MF ring at the infinity end.

Note : If the waveform from infinity to near distance and vice versa does not have duty 50%, perform again "INSPECTION AND ADJUSTMENT FOR THE WAVEFORM OUTPUT FROM MR ENCODER" in P.L13.

Standard H : L = 100 : 206 ~ 206 : 100 (50% ±17.3%)

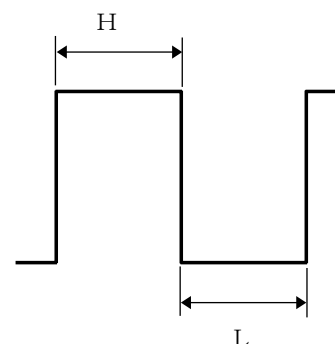

ADJUSTMENT OF DRIVING FREQUENCY AND MOTOR CONTROL

- In case of replacing the main PCB, SWM unit and MR encoder unit, be sure to make adjustments.
 - ① The method of connection of the rated voltage power supply and measuring tools is the same as "ADJUSTMENT OF MR DUTY".
 - ② Make sure that the electric current and voltage of the rated voltage power supply are set to the set values.
 - ③ Turn the rated voltage power supply ON.
 - ④ Select "2. ADJUSTMENT FOR DRIVING FREQUENCY & MOTOR CONTROL" in the menu of the AF-S zoom lens (New) inspection program. The lens automatically starts the driving of scanning.

TYPE OF LENS : AF-S DX NIKKOR 12-24mm/4G	CPU VERSION : 4.00.04
ADJUSTMENT FOR DRIVING FREQUENCY & MOTOR CONTROL.	
ADJUSTMENT IS COMPLETED.	
DOES THE MOTOR STOP DRIVING ? Yes = 1 No = 2	
SELECT THE NUMBER	
PUSH ESC KEY TO RETURN TO MENU	

- ⑤ In case the motor driving remains stopped when the above screen appears, select "1" to end the adjustment.

⚠ Deletion

- ~~In case the motor does not stop driving, select "2" to make adjustments again.~~
- ~~In case the motor does not stop driving even after the readjustments, adjust the MR duty again and repeat "ADJUSTMENT FOR DRIVING FREQUENCY & MOTOR CONTROL".~~
- ~~In case the adjustment is not successful in spite of the above, the SWM unit or cam ring unit may be defective.~~

⚠ Addition

If the motor drive does not stop, select "2" and make the following manual adjustment. If a proper adjustment is not made even after selecting "1", "COULD NOT BE EXECUTED." is displayed, followed by the manual adjustment.

If the adjustment cannot be made even by the manual adjustment, SWM unit or cam ring unit is regarded as malfunctioning.

⑥ Manual adjustment

In case the motor does not stop or automatic adjustment cannot be made, “Fig. 1” is displayed on the screen. At this moment, pressing “1” performs the automatic adjustment again.

If the adjustment cannot be made even after making several automatic adjustments, press “2” for manual adjustment in the following screen.

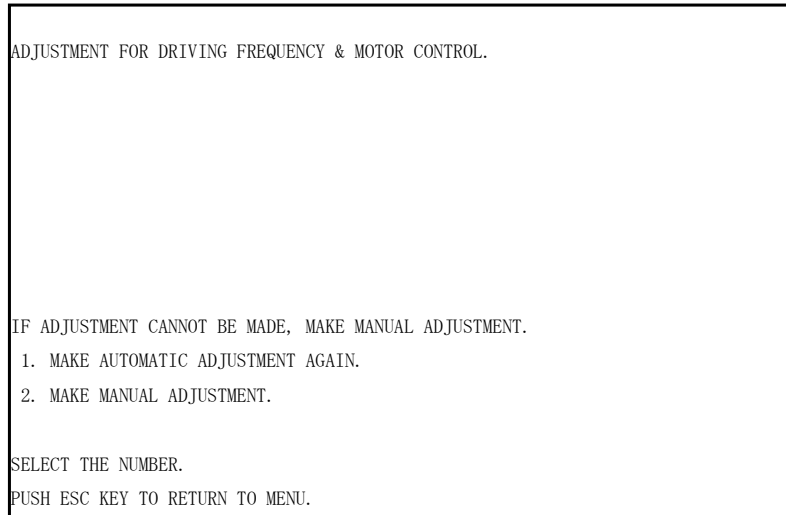

Fig. 1

First, make a low-speed adjustment then a high-speed adjustment.

1. Based on “Fig. 2” on the screen, set the low-speed adjustment for lens and oscilloscope.

Connect the probe of the oscilloscope to the E terminal of the communication-BOX.

Connect GND of the probe to GND of the communication-BOX.

2. Set the oscilloscope so that the time of one cycle of the waveform for E terminal of AF-I communications BOX can be seen.

The time of waveform varies according to the key operation of “1”, “3”, “4”, and “6”, so adjust the time within standard.

The standard shows average value, so sometimes it is acceptable to become an out-of-standard value.

3. Make a high-speed adjustment by following the above same procedure. (Be careful of a different value of standard.)

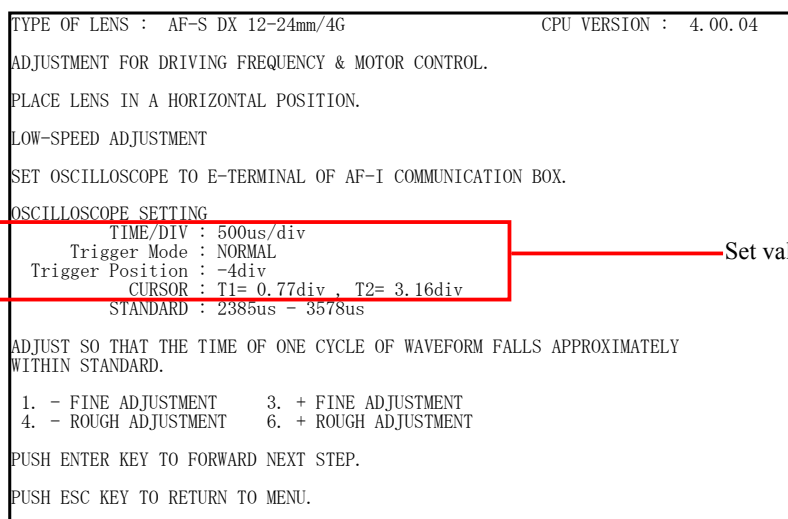

Set value of Oscilloscope DL1540

Fig. 2

e.g.) Oscilloscope (DL1540) setting

As shown in Fig. 2, “div” value within standard is displayed on PC screen.

As shown in Fig. 3, it becomes easy to judge if the standard range of cycle of waveform is set by cursor.

The standard value, TIME/DIV, and CURSOR(T1,T2) varies according to the conditions of low-speed adjustment, high-speed adjustment, and other lenses, etc, so check by Fig. 2 of the PC screen when adjustment is made.

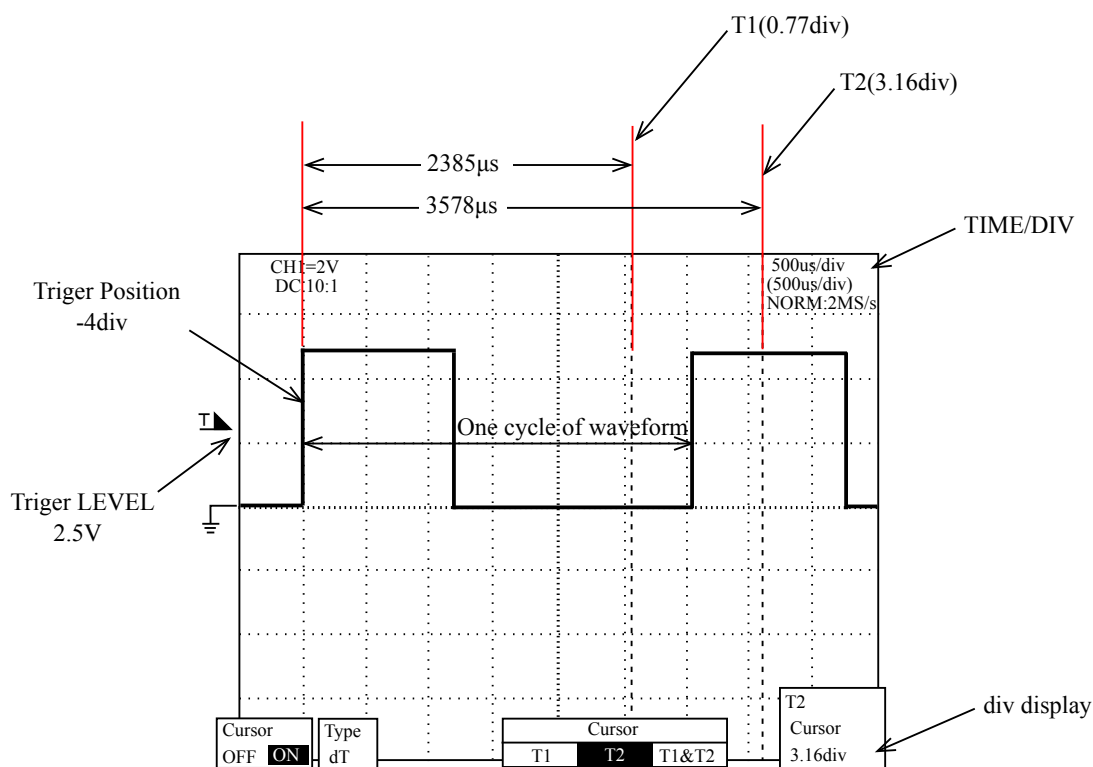

Fig.3

↑ T1/T2Cursor switch-over

LENS OPERATION CHECK

Check the lens operation by using a personal computer after assembling.

○ Check by using a personal computer

● Check items

1 . Operation of MR encoder

- Drive the lenses for scanning and check the difference in pulses at start and at end.
- In case the MR encoder's MR head is not properly attached on the magnetic tape, the difference in pulses is larger.

2 . Lens servo stop accuracy

- Check the overrun/underrun pulses (misalignment of the stop position against the aimed position) for the specified lens actuation.
- When mechanical irregular operation does not occur in the focus ring drive unit, underrun occurs if the cam ring rotary weight of the MR encoder is heavy and overrun occurs if it is light.

3 . Lens servo time

- Check the servo time (time from servo start to stop) with an oscilloscope when the specified lens is actuated.
- When mechanical irregular operation does not occur in the focus ring drive unit, the servo time is long if the cam ring rotary weight of the MR encoder is heavy and is short if it is light.

4 . Check of switches and lenses

- Check the ON/OFF operation of switches and the operation of the distance encoder and zoom encoder.

● How to treat after inspection

1 . When the MR encoder operation is out of standard:

Adjust the MR duty again. (Refer to P. L32.)

If the pulse is out of the standard, adjust the output pulse/waveform from the MR encoder again. (Refer to P. L13.)

If the pulse meets the standard, replace the cam ring unit.

2 . When the lens servo stop accuracy is out of the standard:

Check the output pulse/waveform from the MR encoder. If it is normal, replace the cam ring unit.

3 . When the lens servo time is out of the standard:

Adjust the driving frequency and motor control again.

If the lens servo time is still out of the standard after the readjustment, replace the cam ring unit.

4 . When switches do not operate properly:

Check the wiring pattern of such troubled switch or replace it.

● Explanation of the AF-S zoom lens (New) inspection program

(1) Menu display

```

NIKON AF-S ZOOM LENS (NEW) INSPECTION / ADJUSTMENT PROGRAM.          [J18342]
  1. ADJUSTMENT FOR MR DUTY.                9. -----
  2. ADJUSTMENT FOR FREQUENCY & CONTROL.   A. -----
  3. READ AND REWRITING OF EEPROM DATA.   B. -----
  4. OPERATION OF MR ENCODER.              C. -----
  5. LENS DRIVING STOP ACCURACY.          D. -----
  6. LENS SERVO TIME.                     E. -----
  7. SWITCHES AND LENS CONDITION.         F. -----
  8. -----                               G. RETURN TO THE SYSTEM.

SELECT THE DEMANDED ARTICLE BY <- -> KEY, AND PUSH ENTER KEY.  OR, SELECT
                                                                COMMUNICATE BY RS232C TERMINAL.
THE DEMANDED ARTICLE BY ITS NUMBER.      FOR IBM PC/AT DOS/V CLONE. (486-PENTIUM3)
                                                                COPYRIGHT (C) 2003-05-10 NIKON CORP.
                                                                BORLAND C++ VERSION 3.1 COPYRIGHT (C) 1992 BORLAND INTERNATIONAL.
    
```

• Menu items

The items 1 and 2 are used for adjustment.

The item 3 is used for reading and writing EEPROM DATA.

The items 4~7 are used for inspection.

• Selection of item

After selecting any item, one of the lens selection display, the focal length selection display, the voltage setting display, the inspection start display, etc. appears. The displays are different for the items. Obey the instructions of a personal computer.

• Operating voltage

	Power supply for AF motor in lens	Power supply for AF-I communication box
Inspection of MR encoder operation	6 . 0 ± 0 . 1 V	5 . 5 ± 0 . 2 V
Inspection of lens servo stop accuracy	6 . 5 ± 0 . 1 V	
Inspection of lens servo time	6 . 5 ± 0 . 1 V	
Inspection of switches and lenses	6 . 0 ± 0 . 1 V	

• Initial driving

When "WAIT FOR SOME SECOND" is displayed, execute initial driving (repeat scanning five times and stop at infinity end).

(2) Display of "OPERATION OF MR ENCODER"

TYPE OF LENS : AF-S DX NIKKOR 12-24mm/4G	CPU VERSION : 4.00.04
OPERATION OF MR ENCODER.	
INSPECTING.	
PUSH ANY KEY TO FORWARD NEXT STEP.	

Note : If the MF ring is rotated during lens scanning, an error value is shown for the pulses. Don't touch the MF ring during operation.

Execute inspection for the 5 postures as mentioned below.

(Lens posture at inspection)

Lens inclination	Position of index window
Horizontal	Up, right and left
Front lens group 90° upward	
Front lens group 90° downward	

When the inspection is ended, the above display appears.

Press any key, and the inspection result in the next page appears.

The difference between the pulses before and after inspection must be within the standard.

Standard of difference between the pulses : 0 ± 10 PULSE(S)

Standard of all pulses : 2460 ± 94 PLUSE(S)

TYPE OF LENS : AF-S DX NIKKOR 12-24mm/4G CPU VERSION : 4.00.04
OPERATION OF MR ENCODER.

POSITION WHEN CHECK BEGINS. [PULSE(S)] 7987

POSITION WHEN CHECK IS ENDED. [PULSE(S)] 7996

PULSE NUMBER DIFFERENCE BEFORE / AFTER CHECK. [PULSE(S)] -9

STANDARD FOR DIFFERENCE IN THE NUMBER : FROM -10 TO 10 [PULSE(S)]
IN STANDARD.

THE TOTAL NUMBER OF PULSE(S) AT INSPECTION. [PULSE(S)] 2370

STANDARD FOR THE NUMBER : FROM 2366 TO 2554 [PULSE(S)]
IN STANDARD.

PUSH ESC KEY TO RETURN TO MENU.

(3) Display of "INSPECTION OF DRIVING STOP ACCURACY"



```

TYPE OF LENS : AF-S DX NIKKOR 12-24mm/4G          CPU VERSION : 4.00.04
INSPECTION OF DRIVING STOP ACCURACY.
① → NUMBER OF LENS GO-AND-RETURN OPERATIONS.      : 5 / 5 TIME(S).
LENS DRIVING TIMES. (DF0+DF1+DF2+DF3+DF4+DF5+DF6) : 85 TIME(S).
MAXIMUM PULSE. (ABSOLUTE) (DF0+DF1+DF2+DF3+DF4+DF5+DF6) : 3 PULSE(S).
OVER ( OR UNDER ) RUN PULSE(S).                  : -1 PULSE(S).
LENS DRIVING TIMES. : DF1=15 DF2=15 DF3=15 DF4=15 DF5=10 DF6= 5
DIRECTION      : INF - ) CLOSE          CLOSE - ) INF
AMOUNT         : DF1      DF2      DF3      DF1      DF2      DF3
UNDER(-), OVER(+) : (-) (+) (-) (+) (-) (+) (-) (+) (-) (+)
0 - 6         : 0 10  0 10  2 8      3 2   5 0   5 0
7 - 18        : 0  0  0  0  0  0      0  0   0  0   0  0
12 - 18       : 0  0  0  0  0  0      0  0   0  0   0  0
④ → 19 -      : 0  0  0  0  0  0      0  0   0  0   0  0
DIRECTION      : INF - ) CLOSE          CLOSE - ) INF
AMOUNT         : DF4      DF5      DF6      DF4      DF5      DF6
UNDER(-), OVER(+) : (-) (+) (-) (+) (-) (+) (-) (+) (-) (+)
0 - 6         : 0 10  0  5  0  5      5  0   5  0   0  0
7 - 18        : 0  0  0  0  0  0      0  0   0  0   0  0
12 - 18       : 0  0  0  0  0  0      0  0   0  0   0  0
⑤ → 19 -      : 0  0  0  0  0  0      0  0   0  0   0  0
② → RATIO(1)   (%) : Df1=0.00 Df2=0.00 Df3=0.00 Df4=0.00 Df5=0.00 Df6=0.00
③ → RATIO(2)   (%) : Df1=0.00 Df2=0.00 Df3=0.00 Df4=0.00 Df5=0.00 Df6=0.00
PUSH ESC KEY TO RETURN TO FOCAL DISTANCE SET-UP MENU.
    
```

Note : If the MF ring is rotated during lens scanning, an error value is shown for the pulses. Don't touch the MF ring during operation.

The above display appears during lens driving. Execute the inspection for the 5 postures as mentioned below.

(Lens posture at inspection)

Lens inclination	Position of index window
Horizontal	Up, right and left
Front lens group 90° upward	
Front lens group 90° downward	

The pulses of overrun/underrun must be within the standards after the lenses have reciprocated five times ("5/5TIME (S)." in [1] of the display).

Standards RATIO (1) is 40% or less for Df1~Df6. ② of the display
 (Occurrence ratio of 7~18 pulses)

RATIO (2) is 10% or less for Df1~Df6. ③ of the display
 (Occurrence ratio of 12~18 pulses)

Occurrence of 19 or more pulses is zero for Df1~Df6. ④ and ⑤ of the display
 (It is malfunction if there is only one occurrence.)

※ "Df1~Df6" shows the lens driving amount.

(4) Display of "INSPECTION OF LENS SERVO TIME"

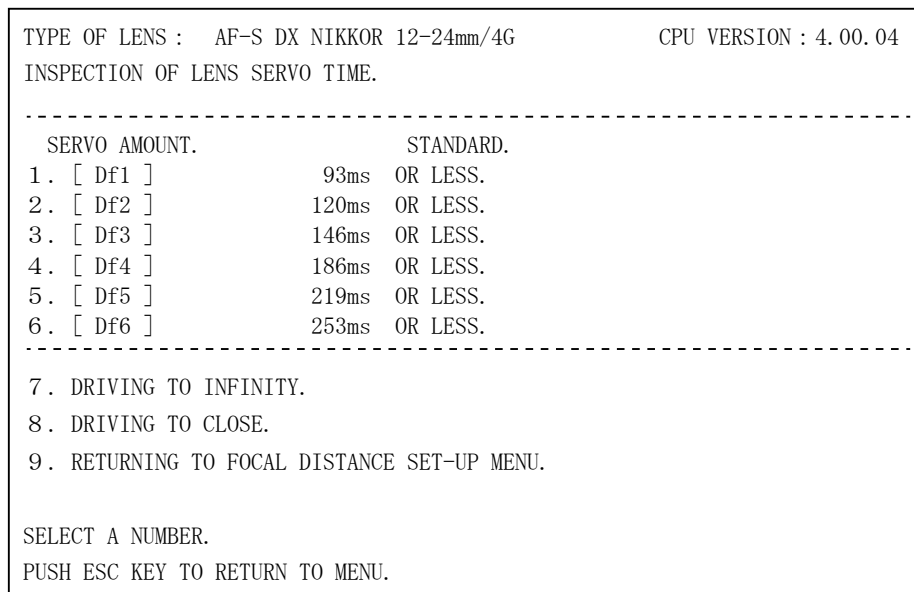

Connect the probes of oscilloscope to E and H terminals of the AF-I communication box (J15306). Select the servo driving amount one by one. Each of the lens servo drive time must be within the standard.

Note : If the MF ring is rotated during inspection, an error value is shown for the waveform. Don't touch the MF ring during inspection. Execute the inspection for the 5 postures as mentioned below.

(Lens posture at inspection)

Lens inclination	Position of index window
Horizontal	Up, right and left
Front lens group 90° upward	
Front lens group 90° downward	

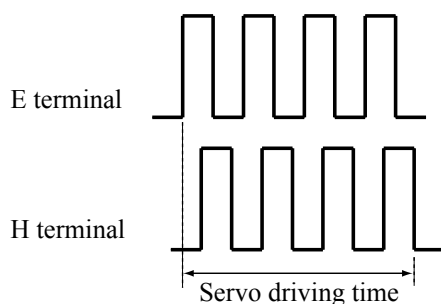

● Setting of oscilloscope

V/Div : 5 V
 Coupling : DC
 Time/Div : 20m Sec
 Trigger Mode : SGL (S)
 Trigger Coupling : DC
 Trigger Source : CH1

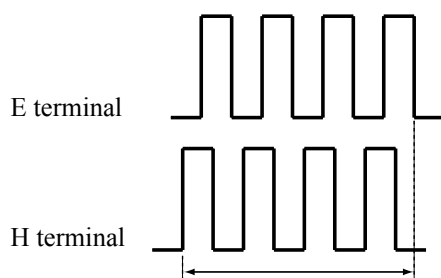

※ There are the start of going up and that of going down for the waveforms of E and H terminals.

(5) Display of "SWITCHES AND LENS CONDITION"

TYPE OF LENS : AF-S DX NIKKOR 12-24mm/4G		CPU VERSION : 4.00.04	
SWITCHES AND LENS CONDITION.		FOCUSING ENCODER	ZOOMING ENCODER :
	:	0-1 17	0 20 :
	:	0-2 18-1	1 21 :
FOCUSING ENCODER	: 0-1	0-3 18-2	2 22 :
	:	0-4	3 23 :
ZOOMING ENCODER	: 0	1	4 :
	:	2	5 :
FOCUS MODE SELECTOR	: M/A	3	6 :
	:	4	7 :
FOCUS LOCK SW	: NONE	5	8 :
	:	6	9 :
FOCUSING RANGE LIMITER SW	: NONE	7	10 :
	:	8	11 :
HELICOID POSITION	: INFINITY	9	12 :
	:	10	13 :
	:	11	14 :
	:	12	15 :
	:	13	16 :
	:	14	17 :
	:	15	18 :
	:	16	19 :
PUSH ANY KEY TO RETURN TO MENU.			

- ① Shows the type of lens.
- ② Shows the version of CPU in the lens.
- ③ Shows the signals of the distance encoder and zoom encoder.
This value is changed if the MF ring is rotated while the lens drive mode selector is at M or M/A.
- ④ Shows the status of switches.
- ⑤ Shows the helicoid position (near distance, medium distance or infinity) according to the distance encoder signal.

Preparation for Inspection & Adjustment of Main PCB

- In case of replacing the main PCB, SWM unit or MR encoder unit, be sure to make the necessary adjustments as follows:

1. Adjustment item

- Adjustment for electrical device (MR duty adjustment, drive frequency/motor control adjustment)

2. Equipment and tools to be required

- Single output rated voltage power supply: 1 unit (6.0V 3.0A)
 - Oscilloscope: 1 unit Adjustment for electrical device (MR duty adjustment, drive frequency/
motor control adjustment)
 Inspection of lens driving time
 - AF-I communication box (J15306-1): 1 unit
 - AF-I communication adapter (J15307): 1 unit
- When the main PCB is replaced, be sure to perform "Writing of EEP-ROM Fixed Values".

AFSZMNEW inspection and adjustment program (J18342)

The below hardware requirements are necessary for installing the program on a computer.

Ensure them before installation.

PC	IBM PC/AT compatible
OS	Windows XP Home Edition, Windows XP Professional, Windows 2000
CPU	Pentium II 266MHz ~ Pentium IV 2GHz
RAM (Memory)	32MB or more
HD	6 MB-or-more free space is necessary when installation
Monitor resolution	800×600 or more pixels
Interface	Serial interface ※ USB interface cannot be used.

As long as the above requirements are met, either desktop or notebook PC is available.



【System configuration】

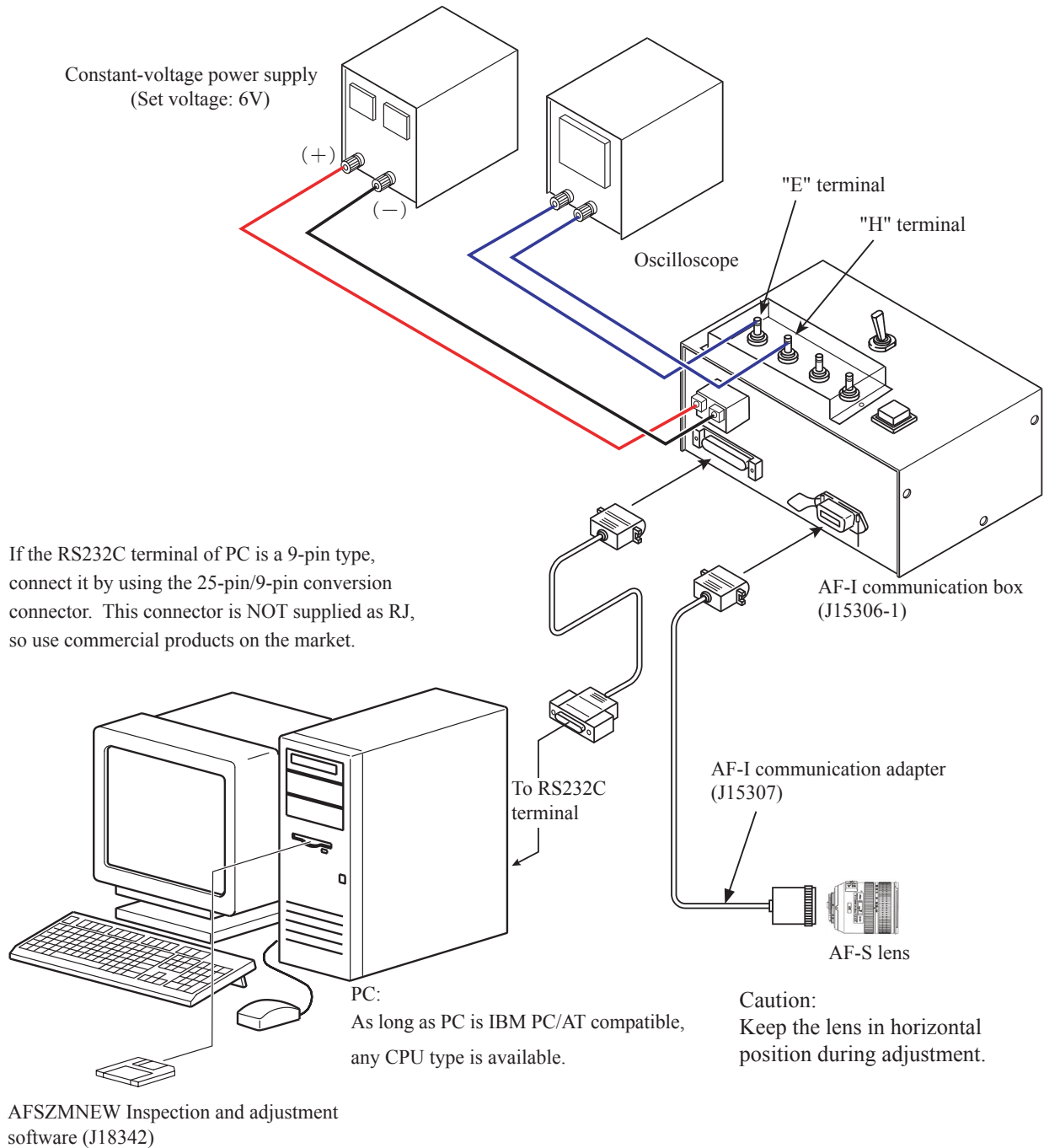

- AF-S Zoom lens (New) inspection program

- (1) Menu screen

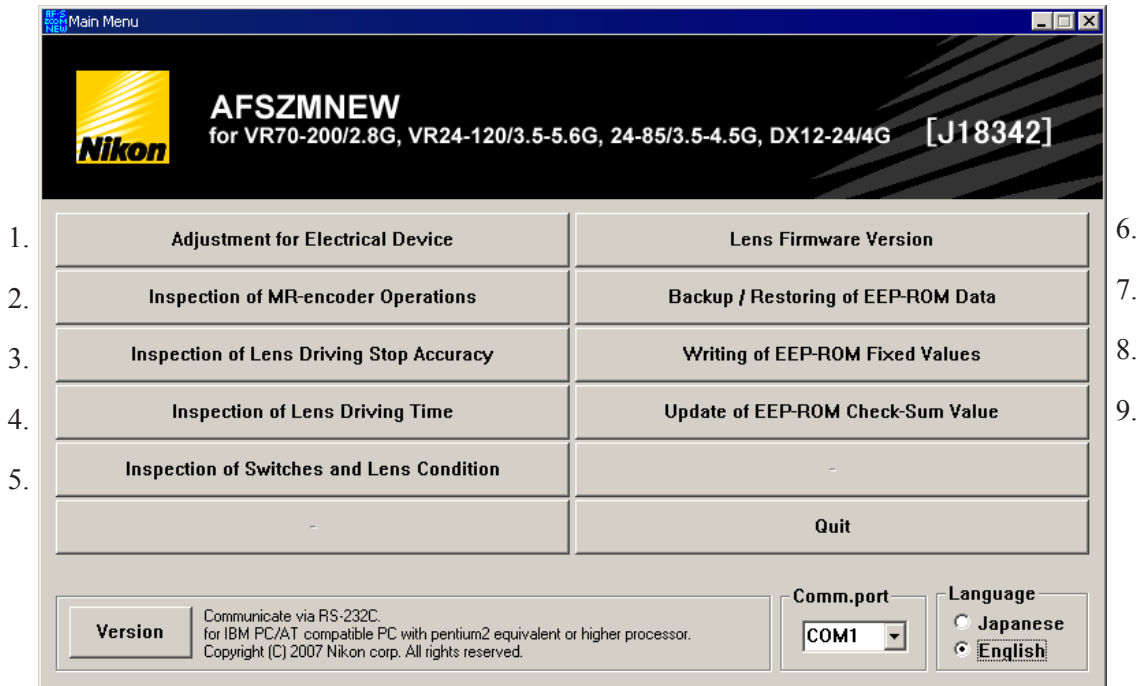

- Menu items

Items 1. is used for adjustments.

Items from 2. through to 5. are used for inspection

Item 6. is used for confirming firmware

Item from 7. through 9. are used for reading/writing EEPROM DATA.

- Selecting items

Depending on selected items, screens appear such as the lens selection, the focal length selection, the voltage setting, the inspection mode entering, etc.

Follow the instructions on PC.

Adjustment for electrical device

- When the main PCB or SWM unit or MR encoder is replaced, be sure to make adjustments.
- When the main PCB is replaced, be sure to perform "Writing of EEP-ROM Fixed Values".

How to adjust:

- ① Confirm that the electric current and voltage of the connected constant-voltage power supply are set to set values, and turn the constant-voltage power supply ON.
- ② Click "Adjustment for Electrical Device" on the menu of AFSMNEW (J18342) inspection program.
(Fig. 1)

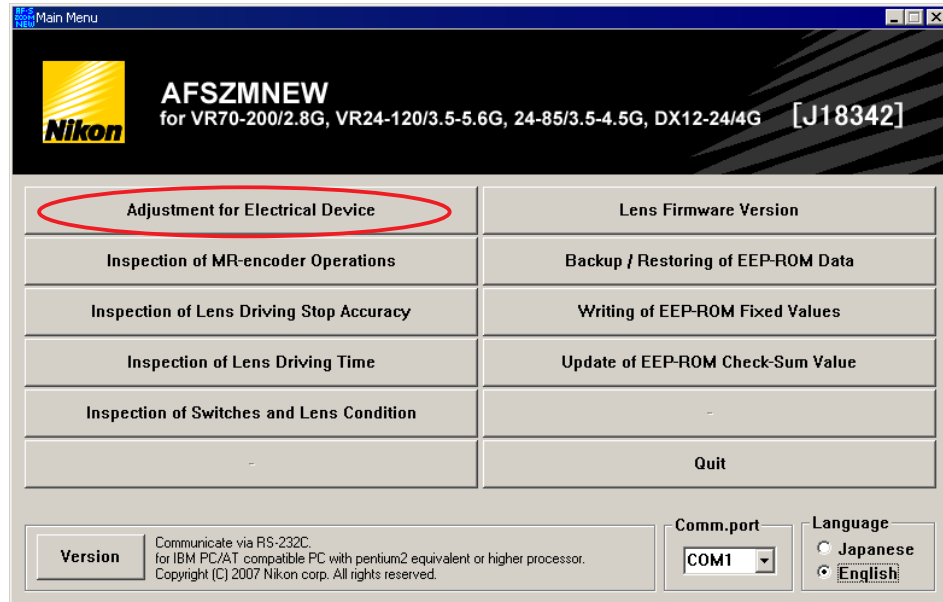

Fig.1

- ③ The screen for "Writing of EEP-ROM Fixed Values" appears. Click the appropriate item. (Fig.2)

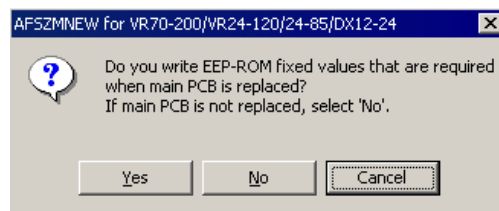

Fig.2

- ④ Following the instructions on the screen, rotate the MF ring in the direction from "Infinity-end" toward "Close-end" slowly by hand. (Fig.3)

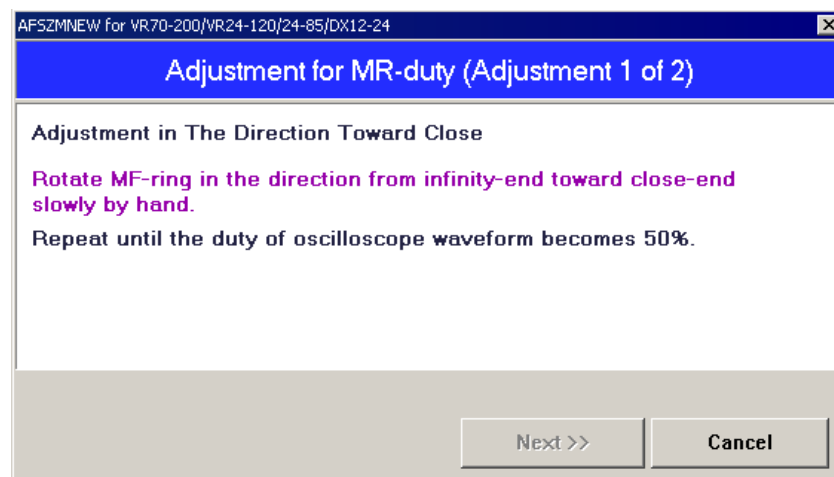

Fig.3



- ⑤ Confirm that the waveform on the oscilloscope has duty 50% and stop the MF ring at the close-end.
(Fig.1)

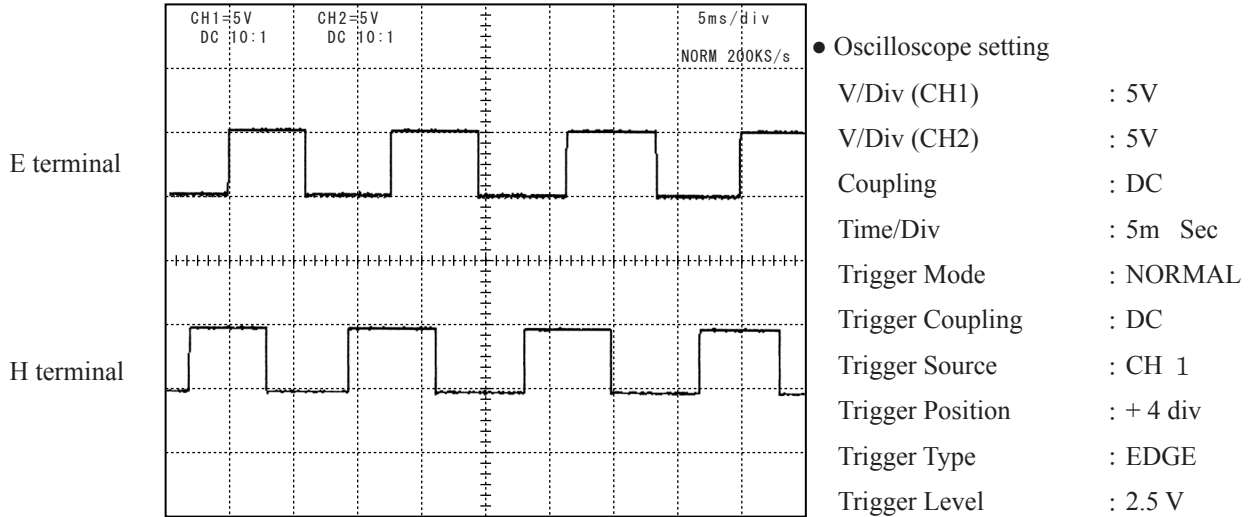

Fig.1

- ⑥ Following the instruction on the screen, rotate the MF ring in the direction from "Close-end" to "Infinity-end" slowly by hand.

Confirm that the waveform on the oscilloscope has duty 50% and stop the MF ring at "Infinity-end".

(Fig.2)

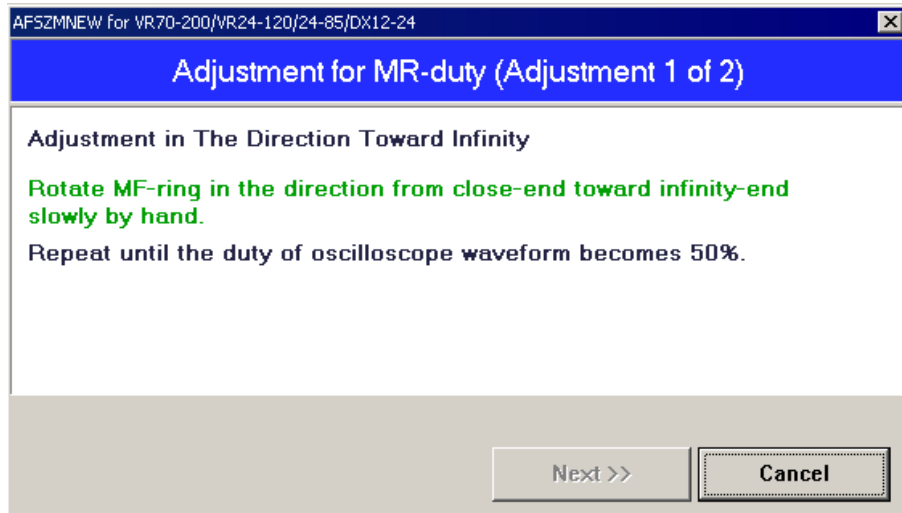

Fig.2

- ⑦ When the adjustment is completed, click "Next". (Fig.3)

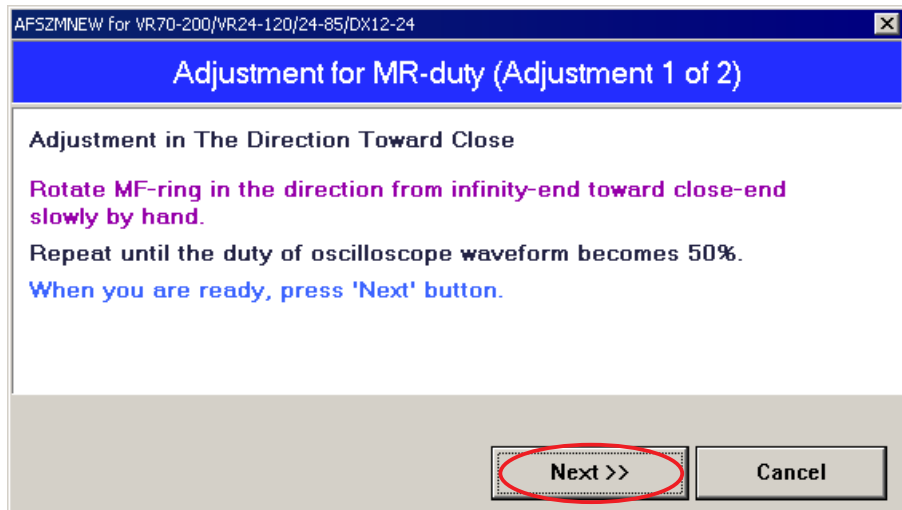
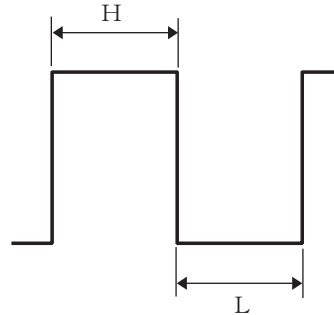

Fig.3

Caution:

If each waveform from "Infinity-end" to "Close-end", or "Close-end" to "Infinity-end" does not have duty 50%, perform "Inspection and adjustment of the MR encoder output waveform" on Page L13-L16 for readjustment.

Standard H:L = 100 : 206 ~ 206 : 100 (50% ±17.3%)



Drive frequency/motor control adjustments

Automatic adjustment

- When the main PCB or SWM unit or MR encoder is replaced, be sure to make adjustments.
- ① Complete the same procedure of the adjustment for electrical device, and click "Next". (Fig.1).
The lens starts scan-driving automatically. (Fig.2)

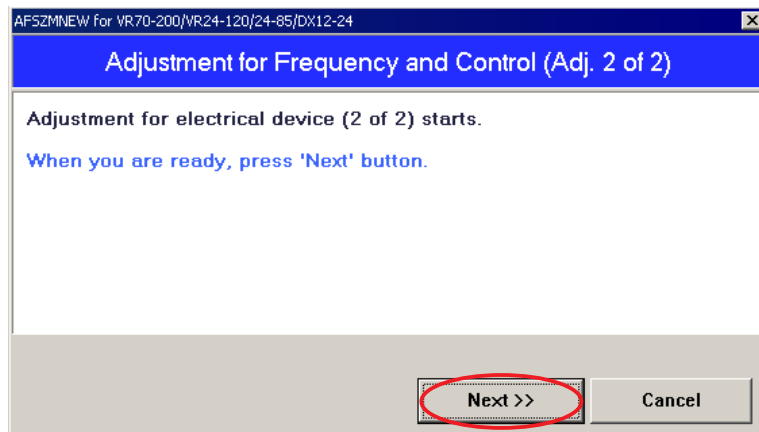

Fig.1

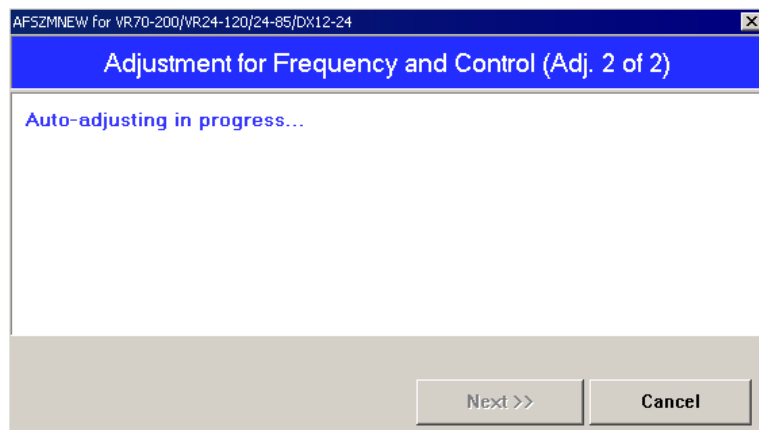

Fig.2



- ② When "Fig.1" screen appears, if the motor driving stands still, click "Close" to end the adjustment.

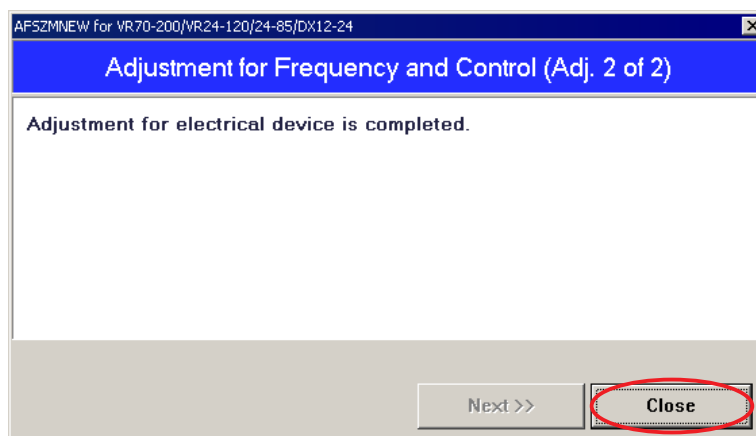

Fig.1

Manual adjustment

- ① If the automatic adjustment failed, "Adjustment could not be completed" (Fig.1) will appear. So click "Yes" and make the manual adjustment.

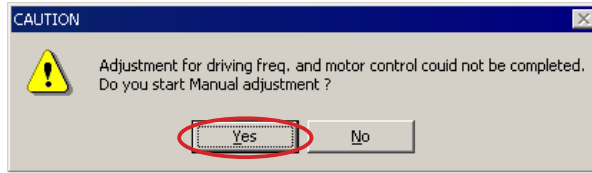
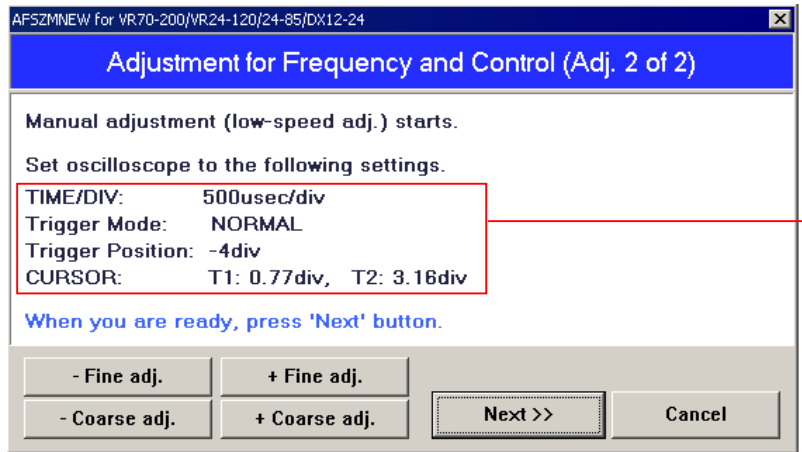

Fig.1

② Low-speed adjustment

1. Set the oscilloscope to the set values of "Fig.2", and make the low-speed adjustment of lens.
2. Click each adjustment of "A section" in "Fig.3", and adjust so that the values become within standards.
3. When the low-speed adjustment is completed, click "Next" of "Fig.3".



Set values of oscilloscope (DL1540)

Fig.2

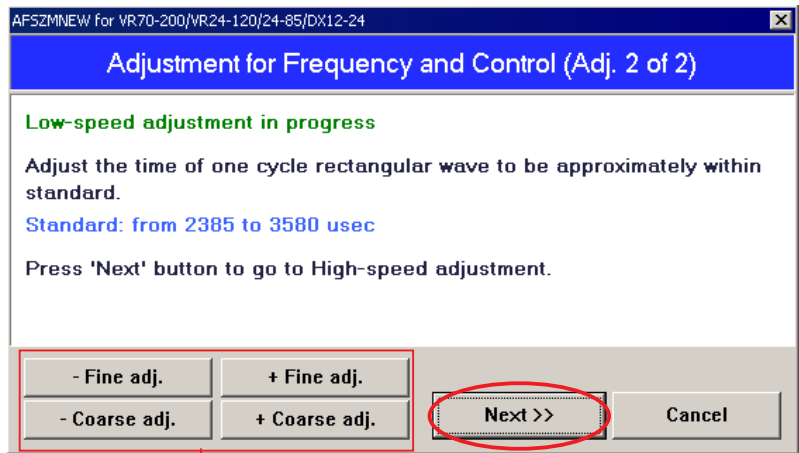

A section

Fig.3



③ High-speed adjustment

Make the high-speed adjustment of "Fig.4" by the same procedure as in the low-speed adjustment.

(Be careful, however, that the setting values are different.)

- When the adjustment is completed, click "Write adj.value" of "Fig.5".

If even the manual adjustment cannot be made, the SWM unit or MR head may be defective.

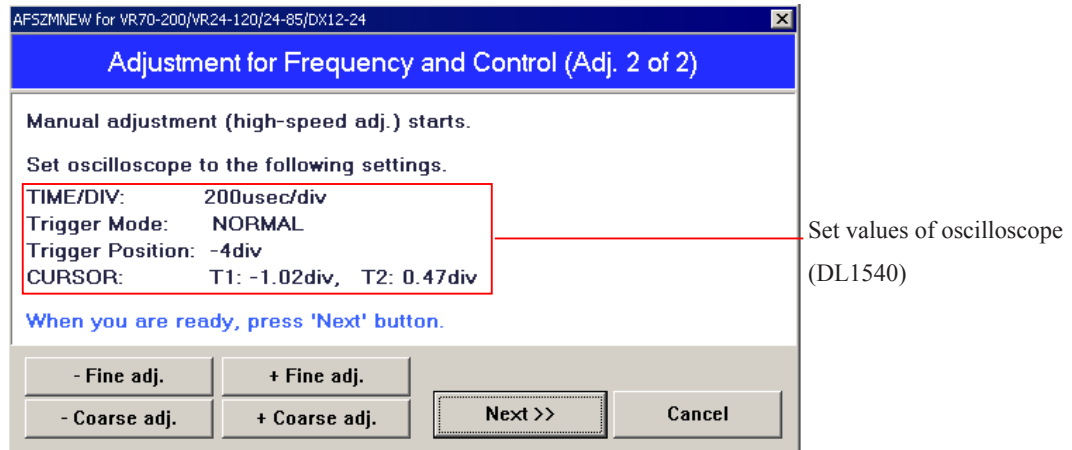

Fig.4

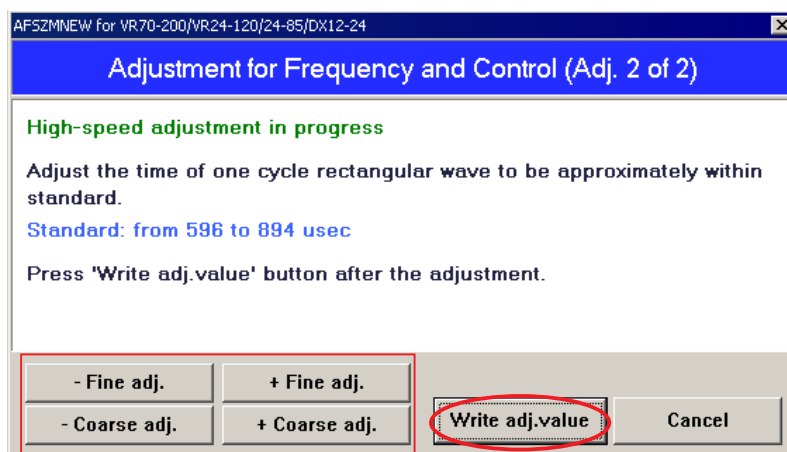

Fig.5

(2) Screen for inspecting MR encoder operation

- ① Click "Start insp." of "Fig.1".

Caution:

When the MR ring is roated during the lens-scan driving, the number of pulses shows an abnormal value. So do NOT touch the MF ring in operation.

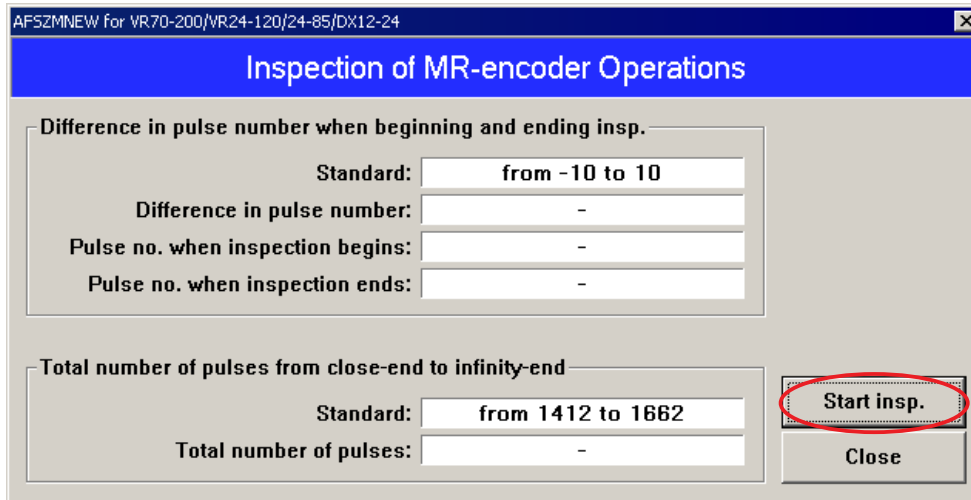

Fig.1

- ② When the operation check is completed, the result is displayed as shown in "Fig.2".
If there is no problem with the result, click "Close".
If there is some problem, make the readjustment by referring to Page L36-16.

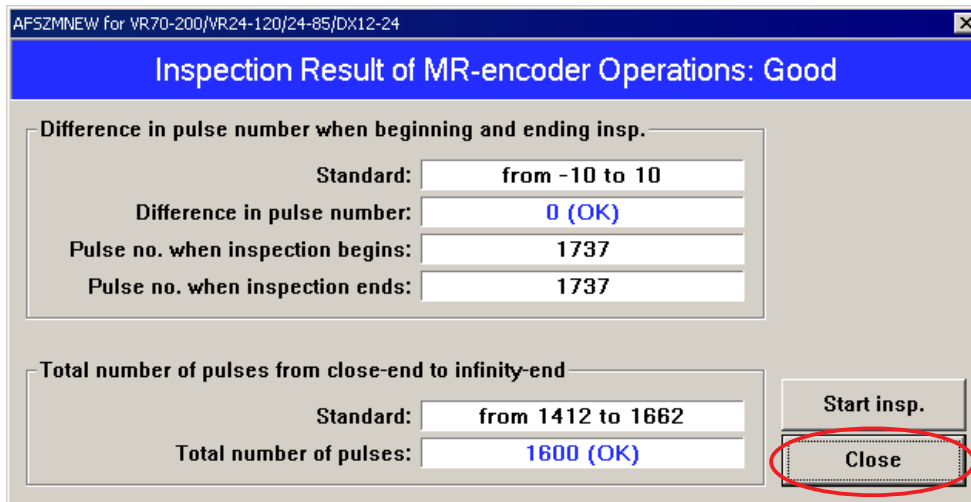

Fig.2

The difference in pulse no. when inspecting must be within standards.

Standard of "Difference in pulse no." : 0±10 PULSE(S)

Standard of "Total no. of pulses": 1537±125 PULSE(S)



(3) Inspection screen of lens driving stop accuracy

① Make this inspection on both focal length 24mm (W) and 120mm (T) at the following five lens positions.

(Lens position when inspecting)

Tilt of Lens	Position of index window
Horizontal	Up / Right / Left
Front lens group 90° angle upward	
Front lens group 90° angle downward	

- ① Click "Start insp.". The inspection of lens driving stop accuracy starts.
- ② If the lens stops during the inspection, input a figure [from "0" to "1000" (msec: millisecond) to delay the process] which prevents stopping the lens, into the below "Delay time" entry field.

Note:

The delay time is the setting value set by the adjustment software. So, if the lens does not stop during "Inspection of Lens Driving Stop Accuracy" in the end, any value can be input without problem. However, the larger the value of "ADJUST DELAY-TIME" gets, the longer the inspection time becomes.

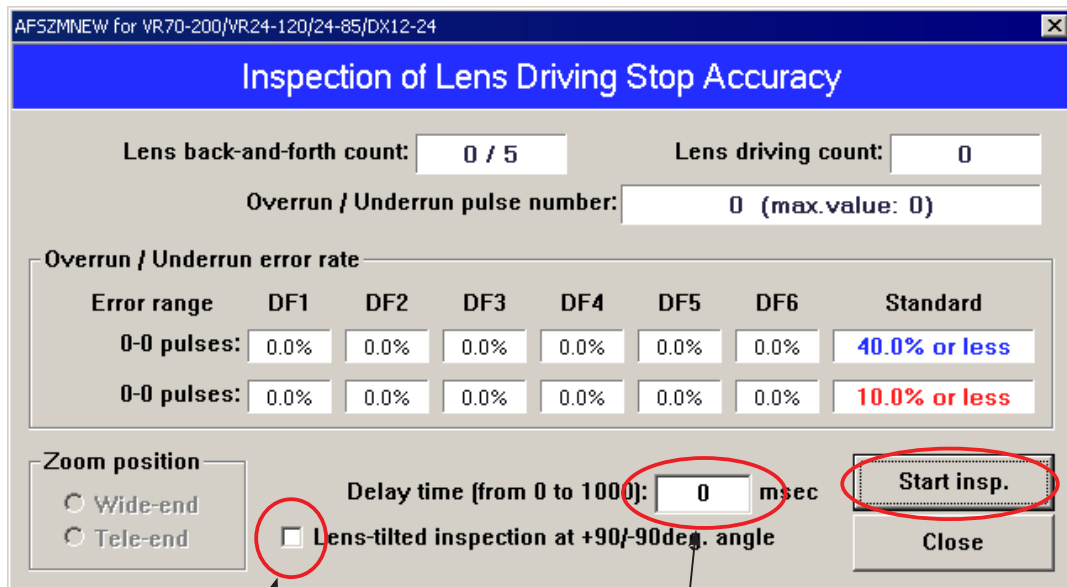

Tick the checkbox when Front lens group 90° angle upward/downward

Entry field



③ During the lens driving, the screen of "Fig.1" appears.

Caution:

When the MR ring is roated during the lens-scan driving, the number of pulses shows an abnormal value. So do NOT touch the MF ring in operation.

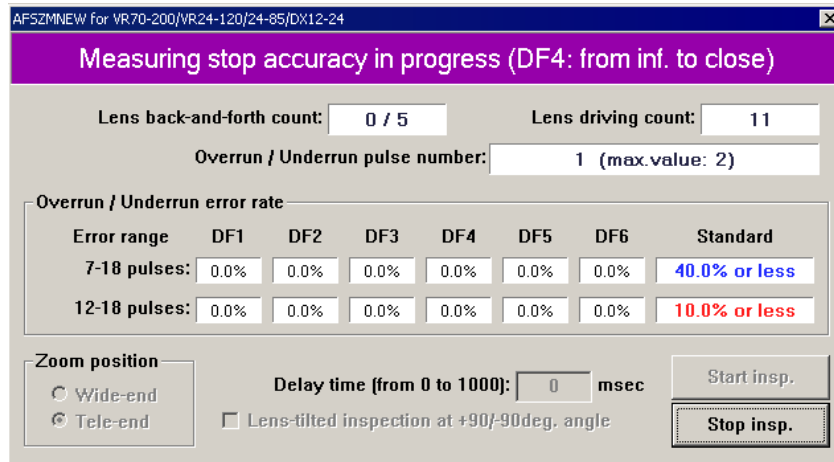

Fig.1

④ The number of overrun/underrun pulses must be within the standards after the lens back-and forth driving-motion five times ("5/5TIME (S)." in ① of Fig.2).

- Standard Df1~Df6: 40% or less (7 - 18 pulse occurrence ratio) ② of "Fig.2"
- Df1~Df6: 10% or less (12-18 pulse occurrence ratio) ③ of "Fig.2"
- 19-or-more pulse occurrence: 0 for Df1 ~ Df6 (Even only one occurrence is judged as defective.) ④ of "Fig.2"

※ "Df1~Df6" shows the lens driving amount.

⑤ When the operation check is completed, the result is displayed as shown in "Fig.2".
 If there is no problem with the result, click "Close".
 If there is some problem, make the readjustment by referring to Page L34-16.

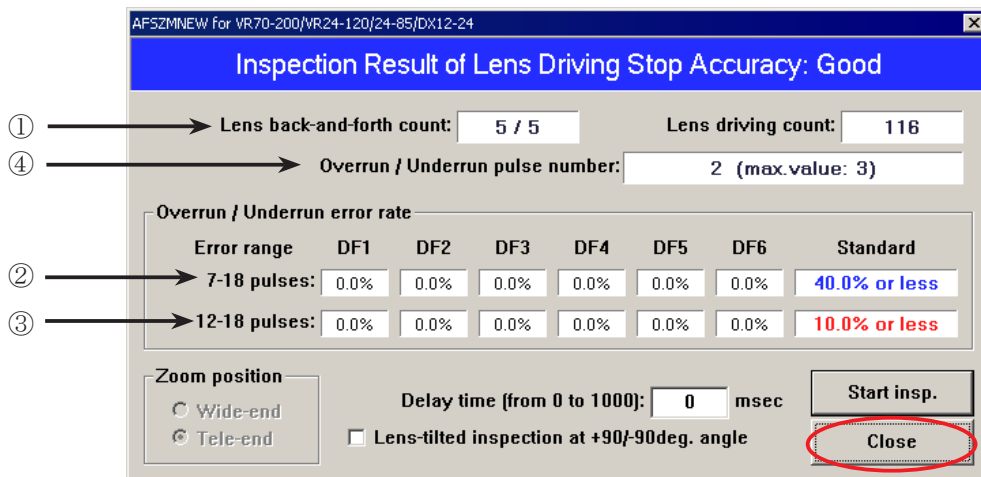

Fig.2



(4) Inspection screen of lens driving time

- ① Make the inspection on both focal length 12mm (W) and 24mm (T) at the five lens positions of "Fig.1".
- ② Select each driving amount. Confirm that each lens driving time is within the standard. (Fig.2)
- ③ If the inspection result is within standard, click "Close" to end. If any of each driving amount becomes out of standard, make the readjustment by referring to Page L34-16.

Caution: When the MR ring is roated during the inspection, the waveform shows an abnormal value. So do NOT touch the MF ring during the inspection.

(Lens position when inspecting)

Tilt of Lens	Position of index window
Horizontal	Up / Right / Left
Front lens group 90° angle upward	
Front lens group 90° angle downward	

Fig.1

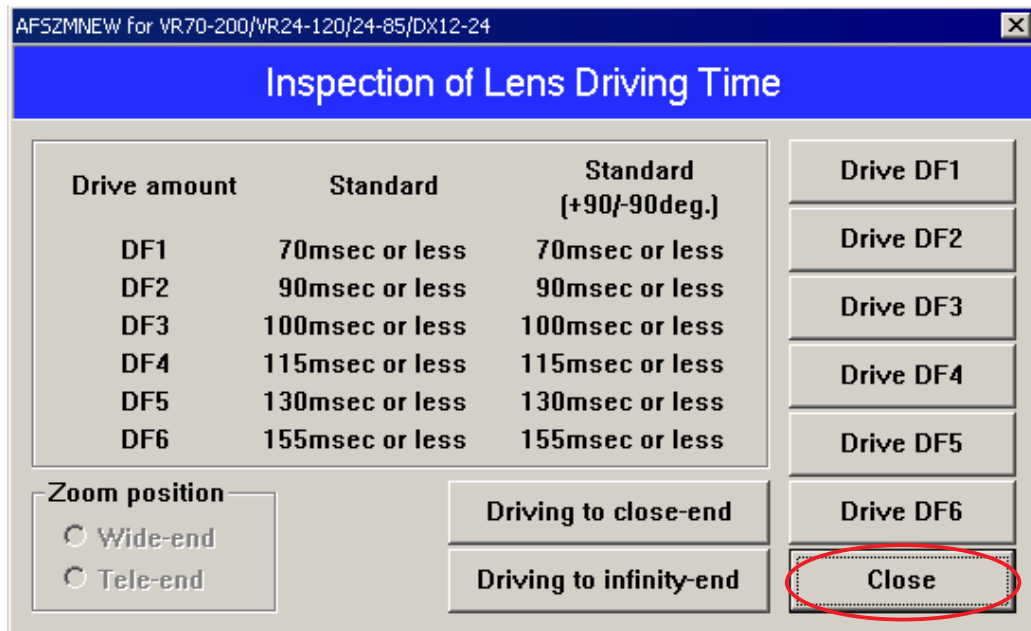
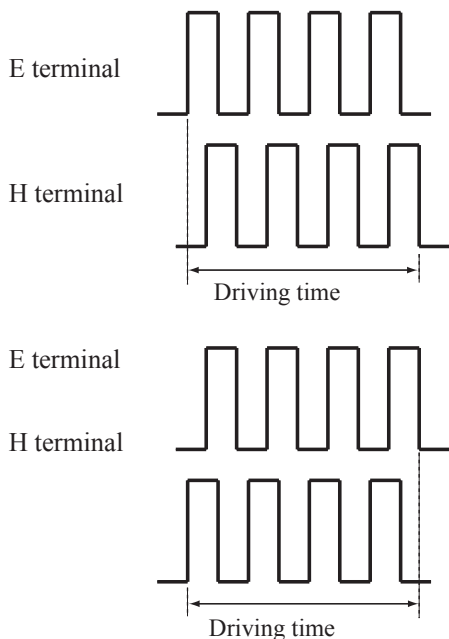

Fig.2



●Oscilloscope setting

- V/Div : 5V
- Coupling : DC
- Time/Div : 20 m Sec
- Trigger Mode : SGL (S)
- Trigger Coupling : DC
- Trigger Source : CH1

※ There are two types in shape of waveforms of E and H terminals:
Waveform (1) starts and goes up (2) starts and goes down.



(5) Inspection screen of switches and lens conditions

- If there is no problem with each item, click "Close" to end. If there is some problem, make the readjustment by referring to Page L34-16.

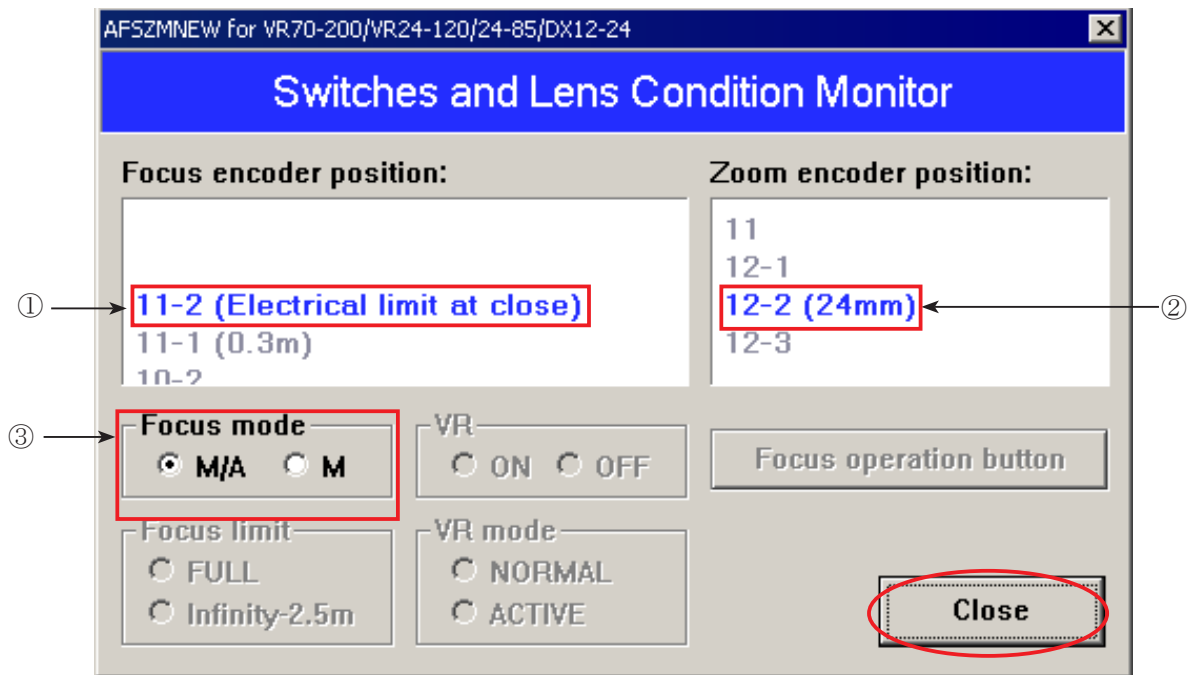

- ① Focus encoder signal
- ② Zoom encoder signal
- ③ Status of focus mode

Oscilloscope: Example of settings for DL1540

- "Fig.2" on Page L34-8 shows setting values for low-speed adjustment, while "Fig.4" on Page L34-9 shows those for high-speed adjustment.
- Setting T1 (min. value) and T2 (max. value) of one cycle of waveform beforehand, as shown by the below dotted lines, facilitates the adjustment.
- Because TIME/DIV, T1, T2, and other setting values are different between the low-speed adjustment and high-speed adjustment, check the values by referring to "Fig.2" on Page L34-8 and "Fig.4" on Page 34-9.

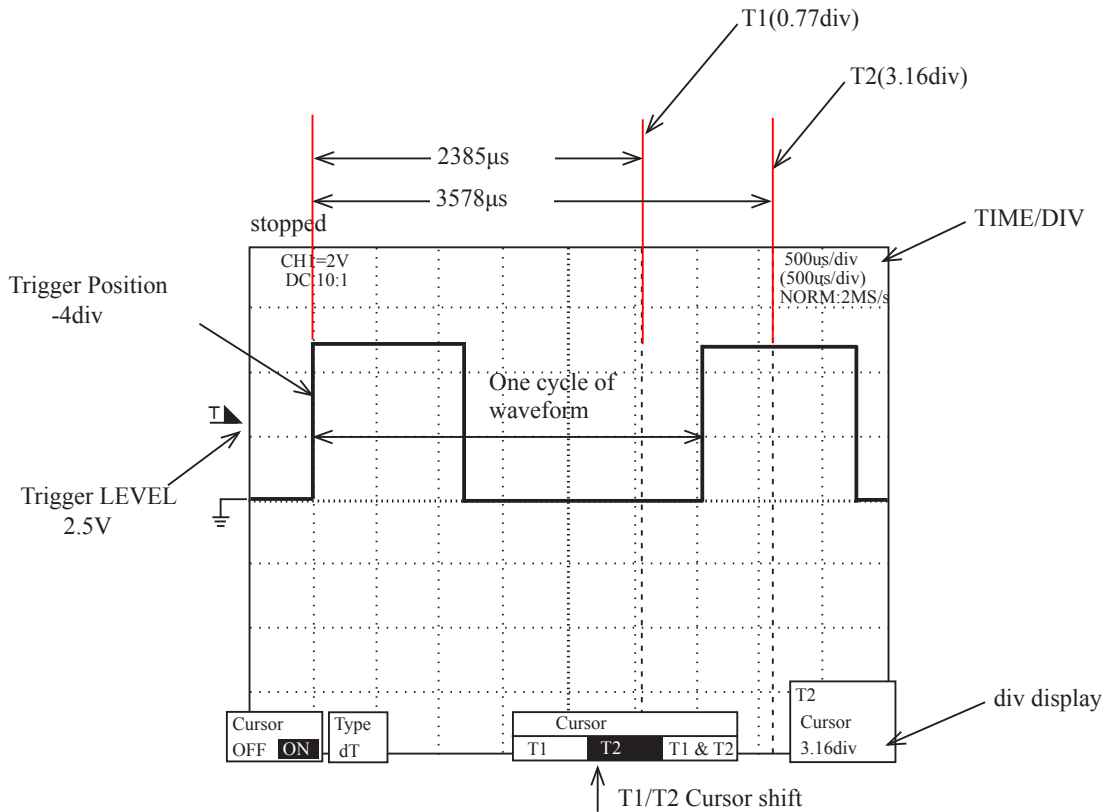

Inspection of Lens operations

Check the lens operations by using PC after assembling.

○ Check by PC

● Inspection item

1. MR encoder operations

- Activate the scanning drive of lens and check the difference in pulse no. when beginning and ending inspection.
- In case the MR head of the MR encoder and the magnetic tape are misaligned, the difference becomes larger.

2. Lens drive stop accuracy

- Check the number of overrun/underrun pulses (deviation of the stop position from the target position) per the specified lens drive amount.
- If there is no variation in mechanical operations of the focus ring driving section, the underrun tends to occur when the cam ring rotation of the MR encoder is heavy, while the overrun tends to occur when the cam ring rotation is light.

3. Lens driving time

- Check the driving time (from starting and stopping the driving) of the specified lens by using the oscilloscope.
- If there is no variation in mechanical operations of the focus ring driving section, the driving time tends to be longer when the cam ring rotation of the MR encoder is heavy, while the driving time tends to be shorter when the cam ring rotation is light.

4. Switches and lenses

- Check the ON/OFF operations of switches and the operating condition of the focus encoder and zoom encoder.

● After inspections

1. When the MR encoder operations are not up to the standard:

Make the readjustment of the electrical device. (ref. Page L34-4 ~ L34-6)

In case the pulse is not up to the standard, readjust the output waveform of the MR encoder.
(ref. Page L15)

In case the pulse meets the standard, replace the cam ring unit.

2. When the lens-servo stop accuracy is not up to the standard:

Check the output waveform of the MR encoder. If it is normal, replace the cam ring unit.

3. When the lens driving time is not up to the standard:

Readjust the driving frequency and motor control.

In case the lens driving time is not up to the standard even after the readjustment, replace the cam ring unit.

4. When switches do not work properly:

Check the wiring state of the troubled switch or replace it.



Aberration compensation data writing adjustment

- This adjustment uses the software which calculates the aberration compensation data according to the feature of lens aberration and writes in EEPROM of the lens, in order to improve the accuracy of autofocus.

Note: This adjustment is necessary when the main PCB and/or each lens part (glass, lens chamber) is replaced or when each lens part is disassembled. Be sure to make this adjustment after completing inspecting and adjusting the main PCB.

(1) Preparation

- Test chart (Self-made tool: ref. Procedure for how to create it.)
- Tripod
- D100
- Personal computer
- USB cable (UC-E4)
- Adjustment software (LWM.exe : used for the lens optical alignment.)

(2) Procedure for how to create Test chart

- Photocopy the next page and cut out 1 target chart and 5 resolution charts.

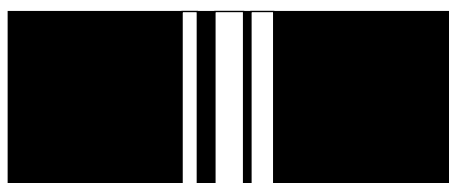

(Target chart)

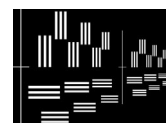

(Resolution chart)

- As shown below, put each chart in position at the specified spacings.

Note: Only about the center, put the target chart on the central resolution chart.

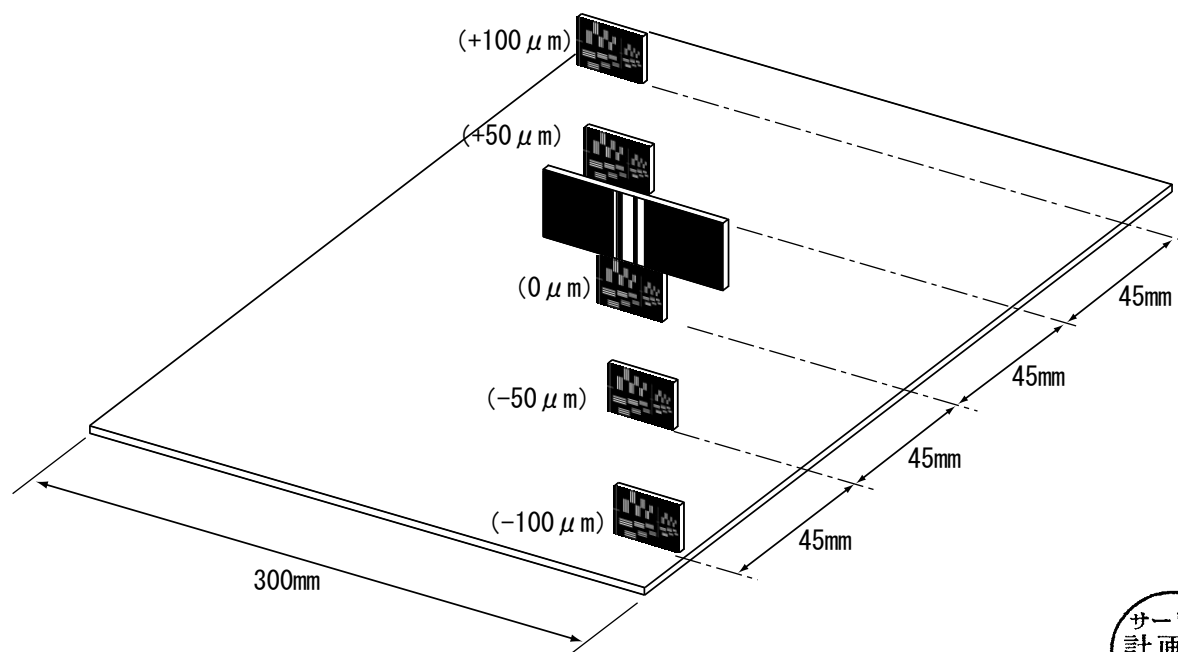

(Target chart)



(Resolution chart)

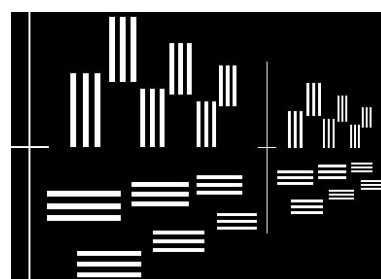
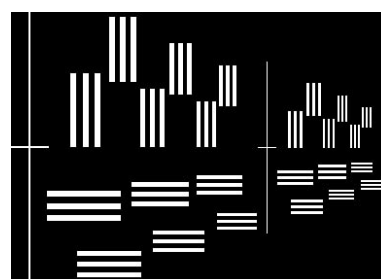

(3) Writing aberration compensation data

- ① Prepare a camera (D100). Set the "Exposure mode" to "A" for full aperture and "Focus mode" to "S".
On the shooting menu, set the "Image quality mode" to "FINE", "Image size" to "L", "WB" to "Preset", and "ISO" to "200".
- ② Set up the camera (D100), in which the lens to be inspected is fit, on the tripod. Set the focal length to 24 mm, and the distance between the test chart and camera (CCD face) to $96\text{ cm} \pm 2\text{ cm}$.

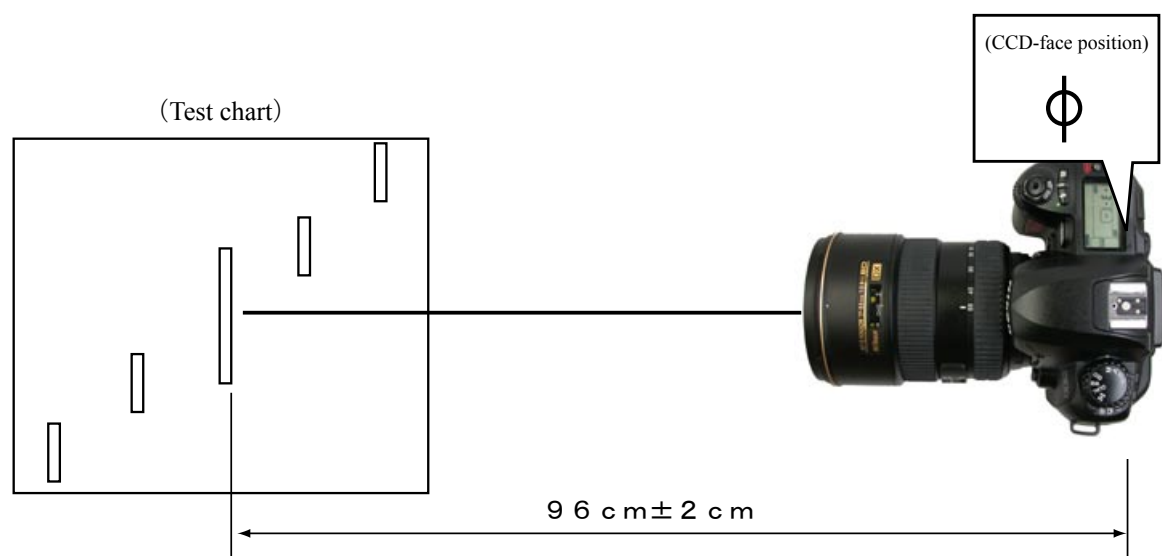

- ③ As shown below, bring the target chart in the center of focus area within viewfinder.

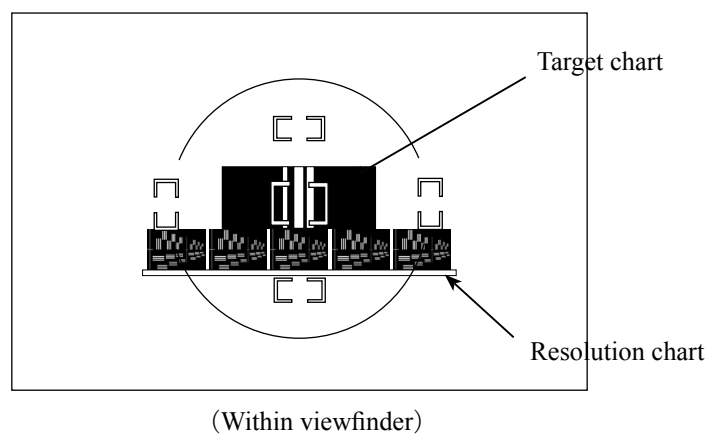

- ④ Connect the PC and camera via USB cable. (Camera setting: Mass storage)
- ⑤ Start the adjustment software (LWM.exe).

- ⑥ "Lens select" window opens. Select "AFS DX 12-24/4G[IF]" and click "OK".
- ⑦ Click the "Defocus rectify..." button.

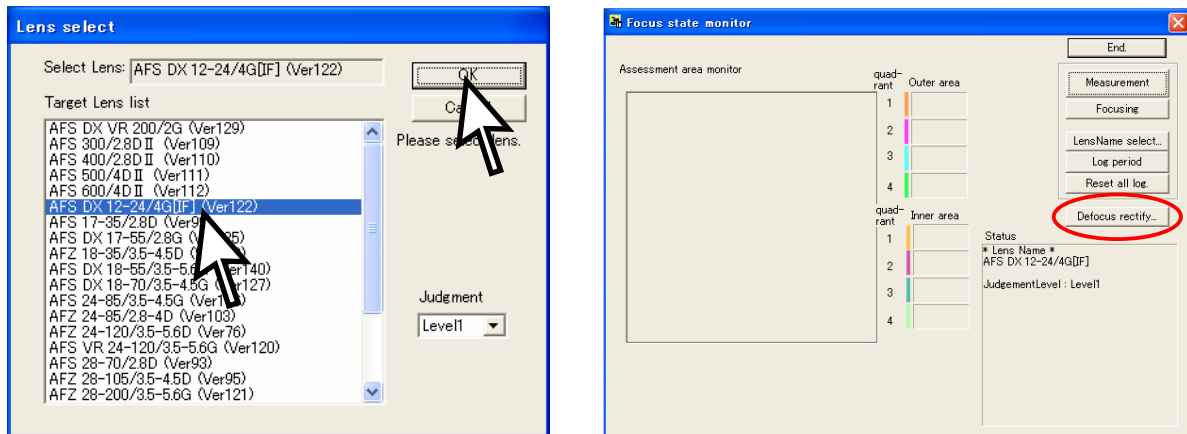

- ⑧ Click the "JPEG Shot" button.

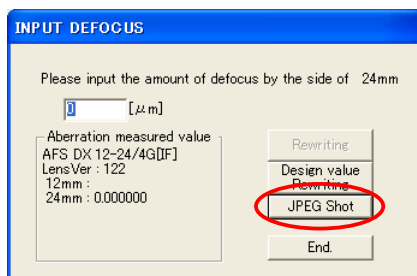

- ⑨ The shutter is released after the AF operation. The shot image is automatically displayed on the PC screen. Scale the image to 100% and check which chart is in focus of the 5 resolution charts.

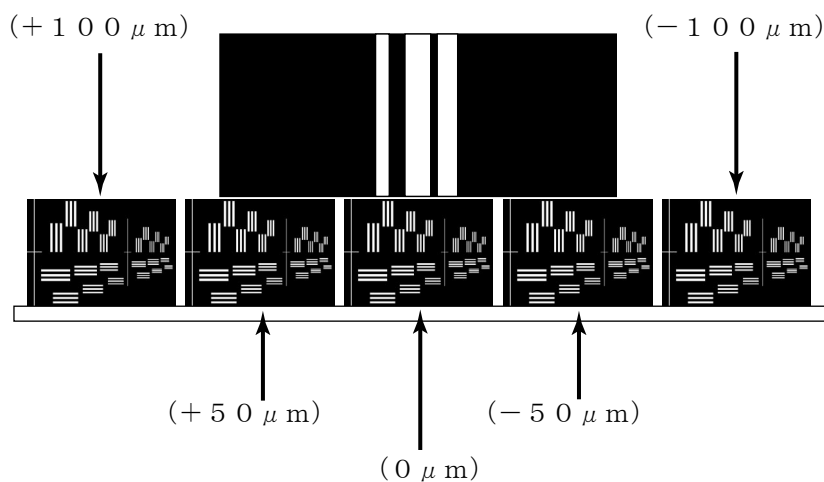

- ⑩ Input the value of the focused position into the entry field.
 e.g. The below is the case when " - 100 μ m" of the front focus side is in focus.

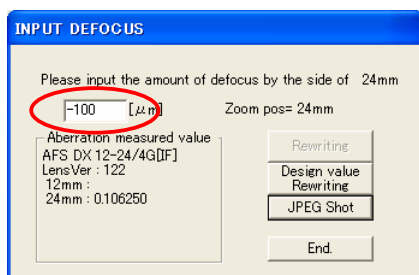

- ⑪ Set the focal length of the lens to 12 mm, and the distance between the test chart and camera (CCD face) to 48 cm \pm 2 cm.
- ⑫ Perform the operations from ⑧ to ⑩ of the previous page.
- ⑬ Check that the values of all the focal lengths are displayed within the dotted red circle. Then click on "Rewriting".

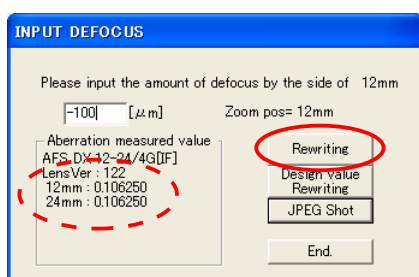

- ⑭ When "A compensation value is written in." is displayed, click "OK".

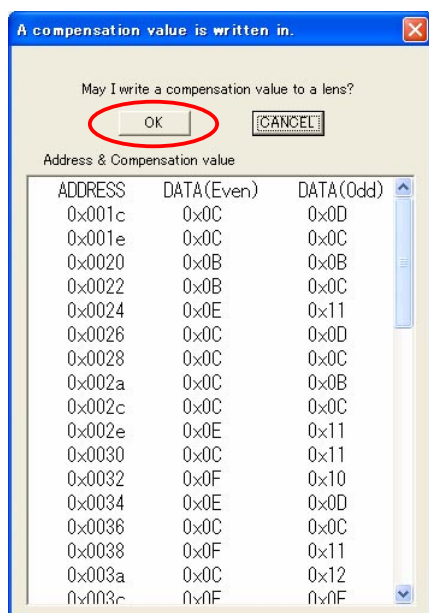

- ⑮ The reconfirmation screen is displayed. Click "OK".

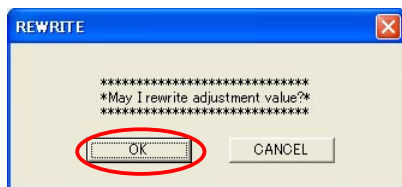

- ⑯ An hourglass is displayed on the screen, and writing starts.

The below screen is displayed after a few seconds. Turn camera OFF and turn it ON again.

Click "OK", and the adjustment software restarts.

Note: Unless the camera is turned off once, the value that was written in EEPROM is not reflected on the results of shooting.

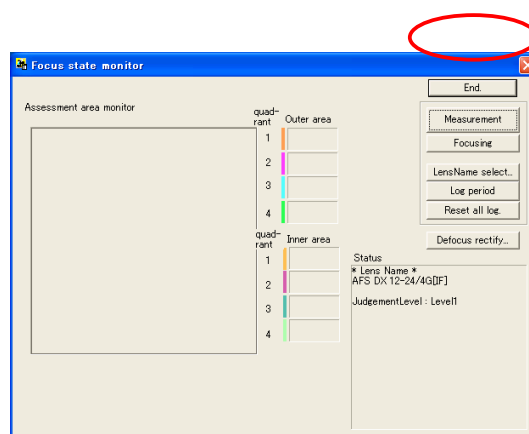
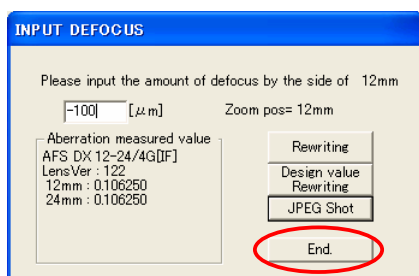
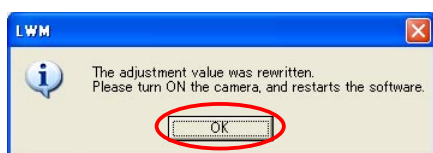

- ⑰ When the adjustment software restarts, perform the operations from ② to ⑫ again. Check that "0 μ m" of the AF position is in focus.

(It is also possible, after Wide-side shooting of ⑪, to take the Tele-side shooting of ②.)

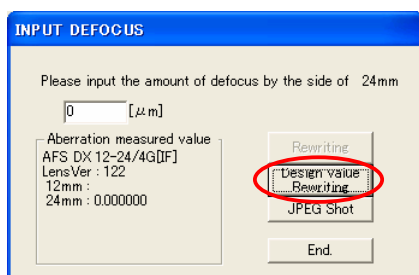

If "0 μ m" is not in focus, repeat the operations from ② to ⑰.

If it is not still in focus even after repetition, the written value in EEPROM may be abnormal. So click "Design value Rewriting" to write the initial value, then proceed with the operations.

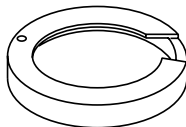
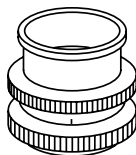

Tools

★ : New tool

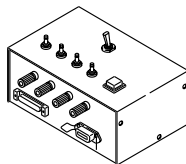
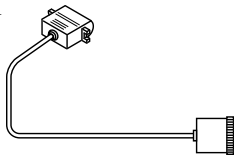
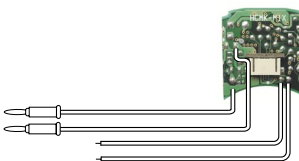
RJ No.	Name	Note
MZ-800S	DRY SURF MZ-800S	
GE-8	GREASE GE8	
EDC0021	ADHESIVE	
EDB0011	SCREW LOCK 1401C	
J18004-1	STANDARD GAUGE FOR J18004 	
J19002	BACK FOCUS COLLIMATER LT-500S	
J18028	LENS ADAPTER FOR FOCUS TESTER 	
★ J18342	AF-S ZOOM LENS (NEW)INSPECTION AND ADJUSTMENT SOFTWARE 	Use the version date after May 10 ,2003.
J15306 or J15306-1	AF-I COMMUNICATION BOX 	
J15307	AF-I COMMUNICATION ADAPTER 	
	PERSONAL COMPUTER	
	POWER SUPPLY	
	OSCILLOSCOP	
	SELF-MADE TOOL 	Use the self-made tool that was created in AF24-85/3.5-5.6G.

Making of self-made tool

- It is necessary to make a self-made tool by using the main PCB of repair part. The self-made tool will be used for "INSPECTION AND ADJUSTMENT FOR THE WAVEFORM OUTPUT FROM MR ENCODER". The making procedure is shown below. Make a self-made tool according to this procedure.

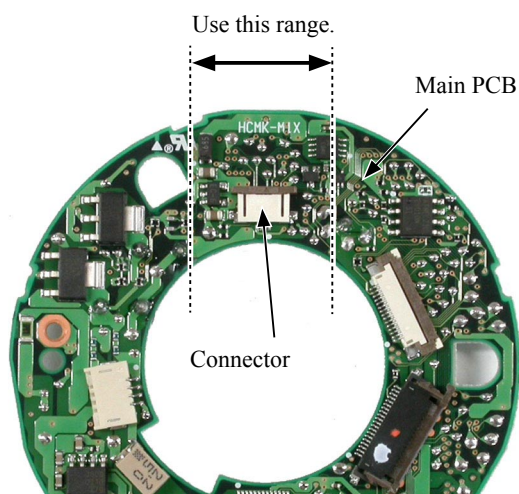

- ① Remove the elements (condenser, transistor, IC, etc.) installed within the dotted line as shown in the left from both sides of PCB. Don't remove the connector.
- ② Cut the PCB at the dotted line.

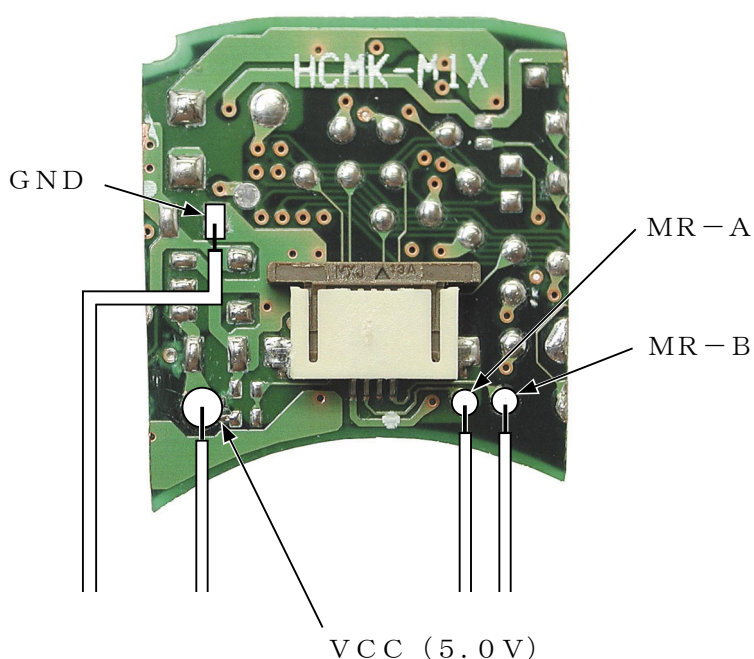

- ③ Solder the cords at 4 pattern places on the PCB as shown in the left.

外觀図 Sketch drawings

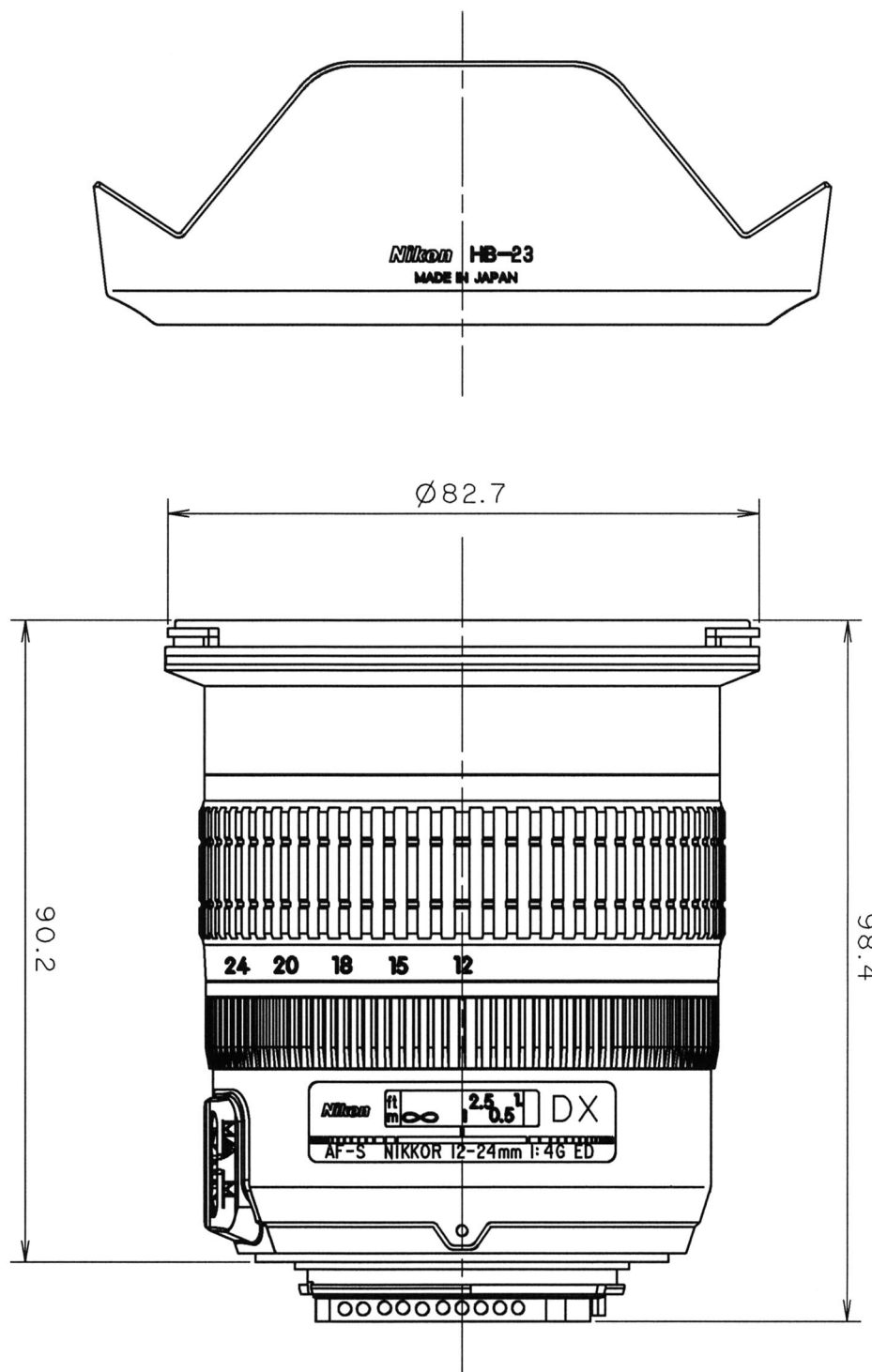

組立図 Structure of the Lens

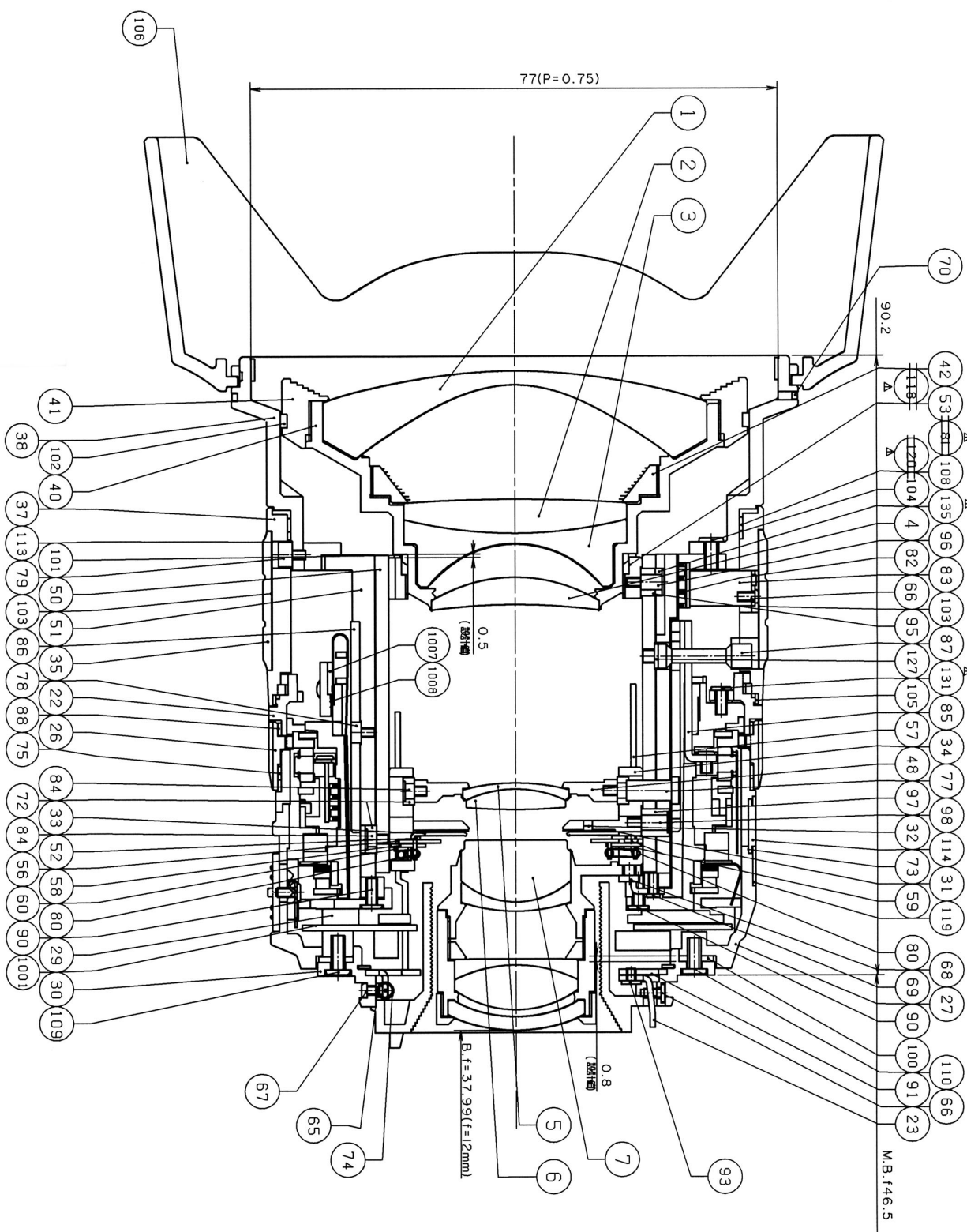

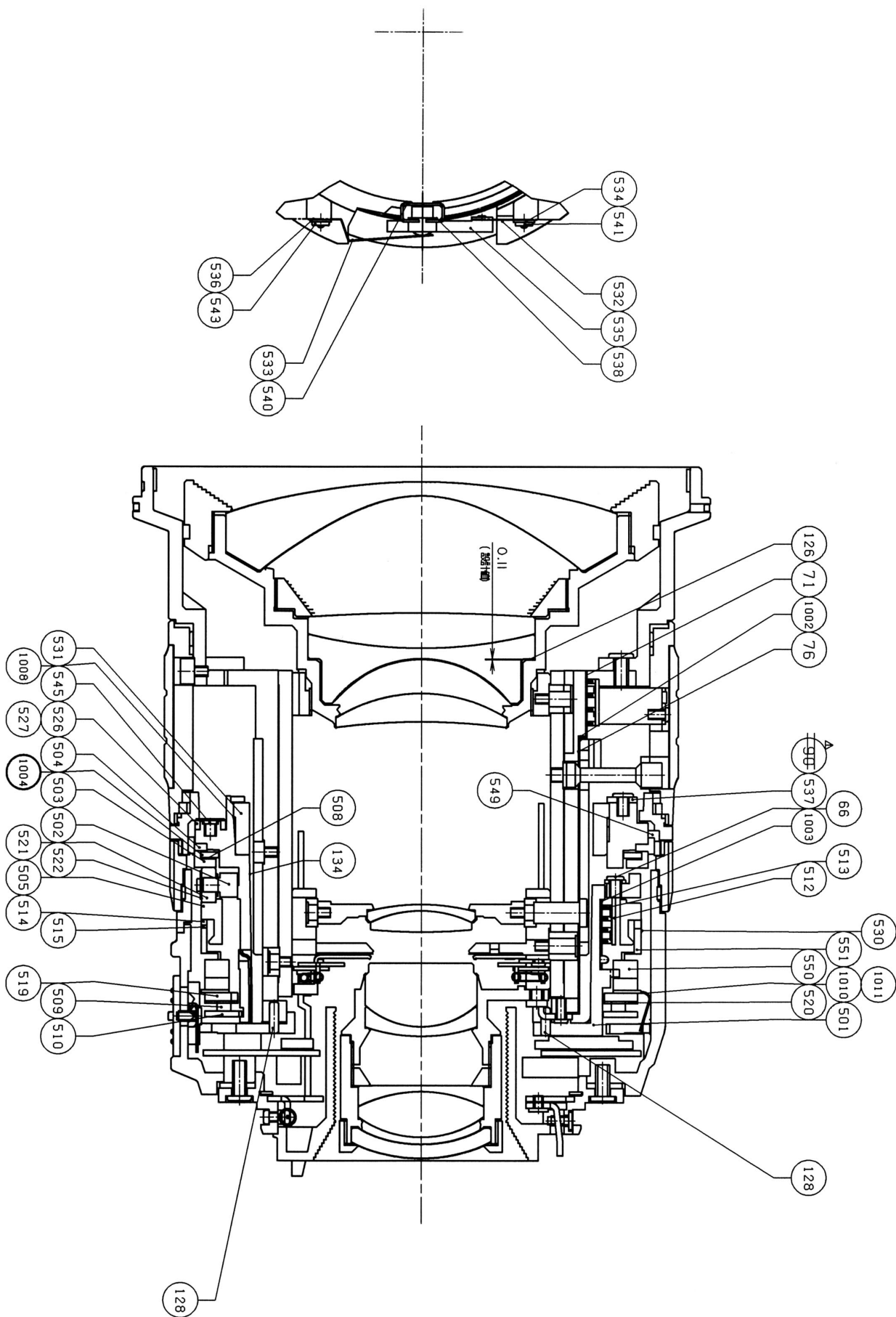

実体配線図
WIRING DIAGRAM

