

作成承認印

配布許可印



D300 VBA20001

REPAIR MANUAL



Nikon | NIKON CORPORATION
Tokyo, Japan

Copyright © 2007 by Nikon Corporation.

All Rights Reserved.

無断転載を禁ず!!

Points to notice for Disassembly and Assembly

 WARNING	
	<ul style="list-style-type: none"> ● Take extra care not to get an electric shock when detaching covers. ● After removing covers, be sure to discharge the main condenser according to the instructions of repair manuals.

Caution:

- ① In disassembly/(re)assembly, be sure to use conductive mat (J5033) and wrist strap (J5033-5), in order to protect electric parts from static electricity.
- ② Before disassembling, be sure to remove batteries or AC power cord.
- ③ In disassembling, be sure to memorize the processing state of wires and FPC, screws to be fixed and their types, etc.
- ④ The low-pass filter of the image PCB/base plate is easily damaged. Handle it very carefully.
- ⑤ NK is indicated in this manual when NK screw is used. Usually the same "NK" screw can be used approx. up to three times. (NK screw = Loose-proofing screw to which the adhesive is already applied and firmly fixed when screwed in.)

Points to notice for Lead-free solder products
<ul style="list-style-type: none"> ▪ Lead-free solder is used for this product. ▪ For soldering work, the special solder and soldering iron are required. ▪ Do NOT mix up lead-free solder with traditional solder. ▪ Use the special soldering iron respectively for lead-free solder and lead solder. <p style="margin-left: 20px;">They cannot be used in common.</p>

Caution:

When "Separation of Front body from Rear body", "Disassembly of CCD/FPC unit" and "Disassembly of Bayonet" are performed, be sure to carry out "RESET AF-DEFOCUS COMPENSATION" of the D300 adjustment software after assembly.

Disassembly

1. External area and Image-related PCB/base plate

External rubber

※ Caution: Take out the screw (#1647) first, and then remove the grip rubber (#B60).

- Remove the external rubber (#B60, #B61, #B63, and #B447).

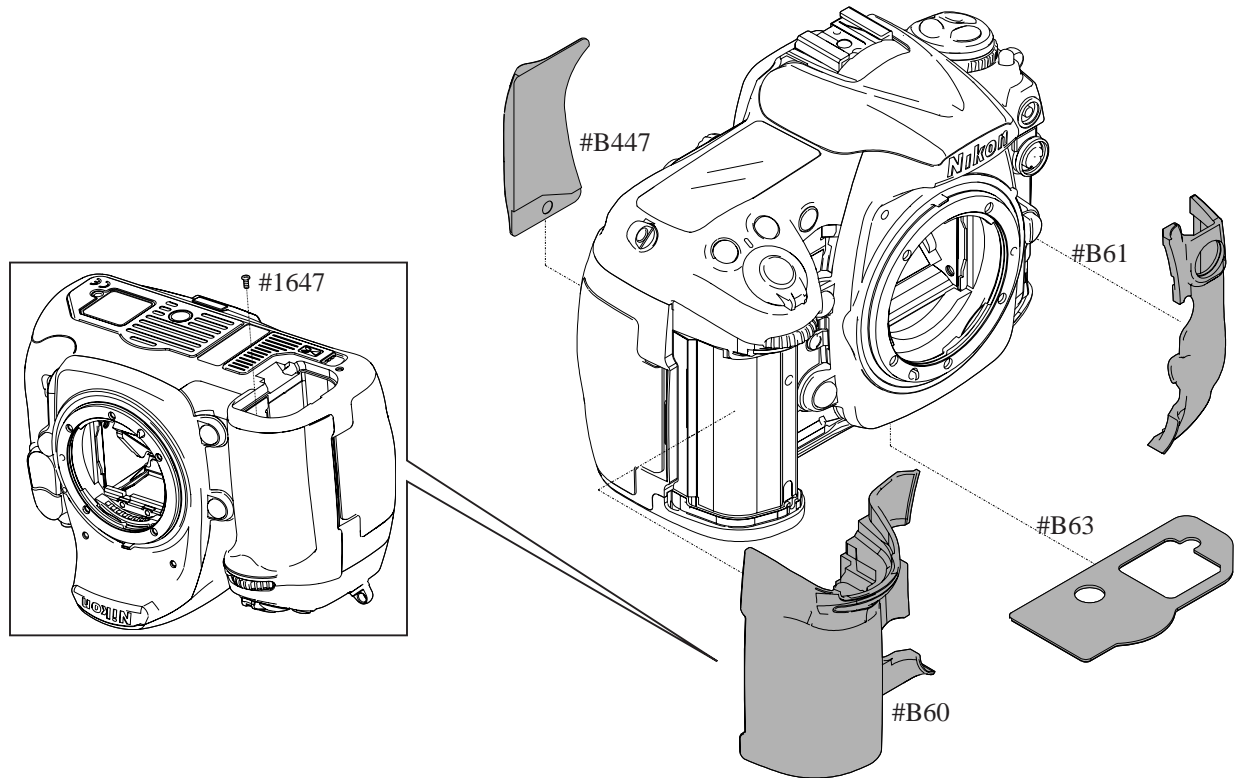

IF lid

- Take out the two screws (#1642).
- Remove the IF lid (#392).

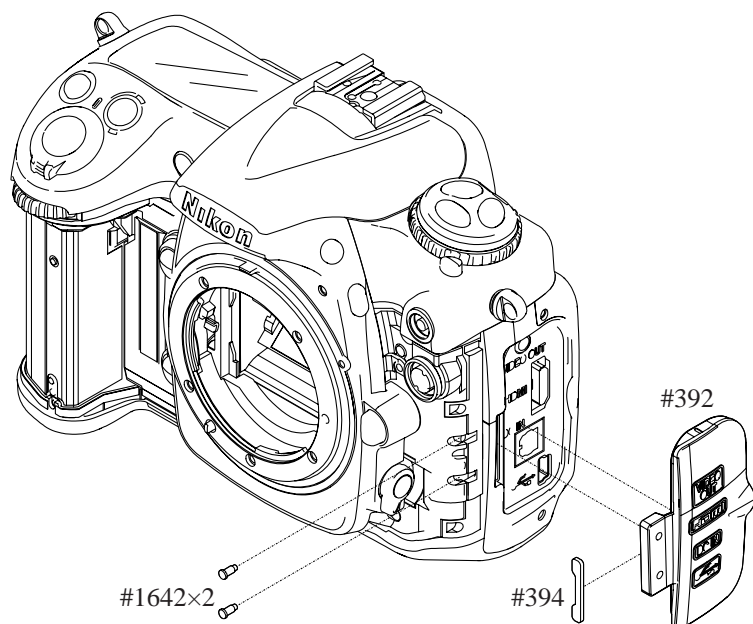

Bottom cover / Battery lid unit

- Open the battery lid (#B801) approx. 45-degree upwards, and remove as if pulling it out.
- Take out the three screws (#1550), five screws (#1556), two screws (#1509).
- Remove the bottom cover.

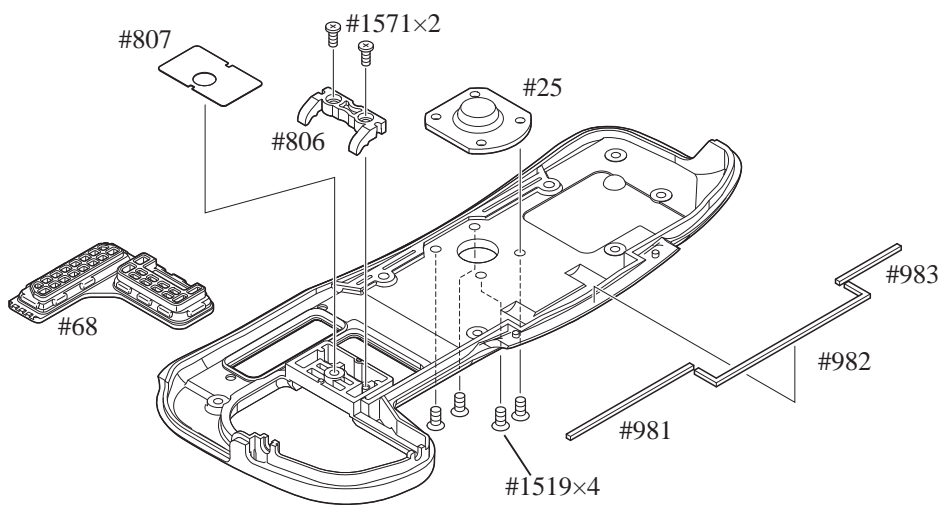
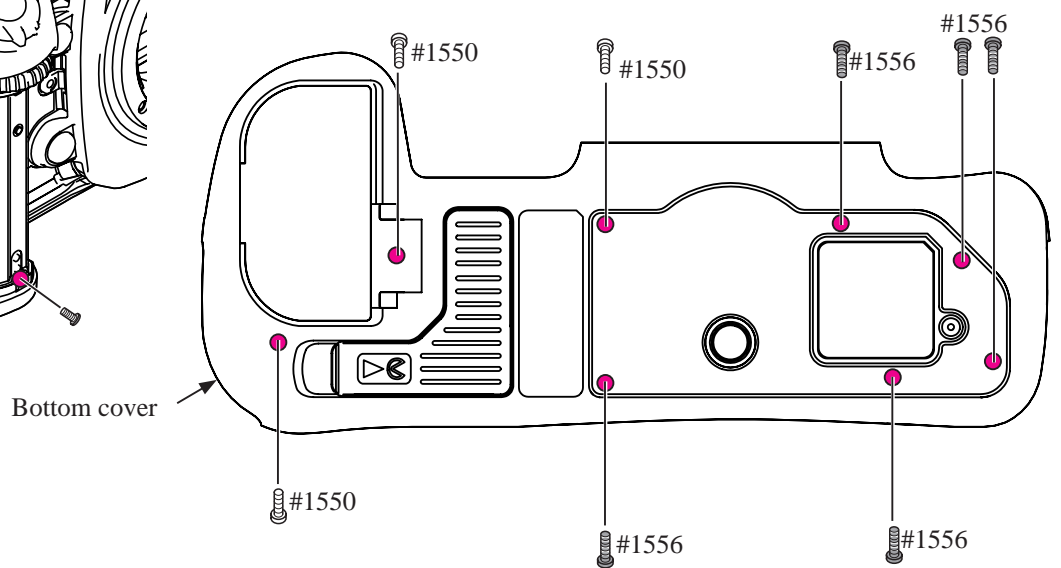
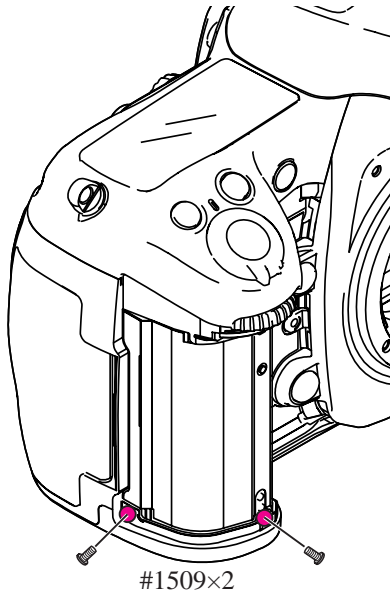
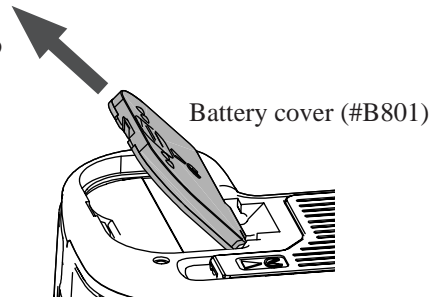

Rear cover unit

- Take out the two screws (#1553), two screws (#1547) and one screw (#1551).
- Remove the rear cover slowly, and disconnect the three FPCs from each connector.

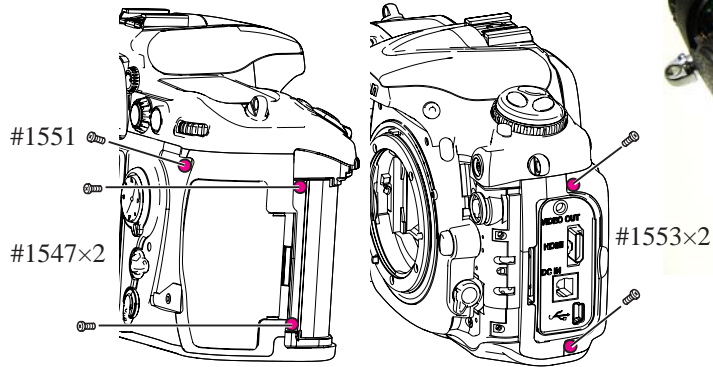
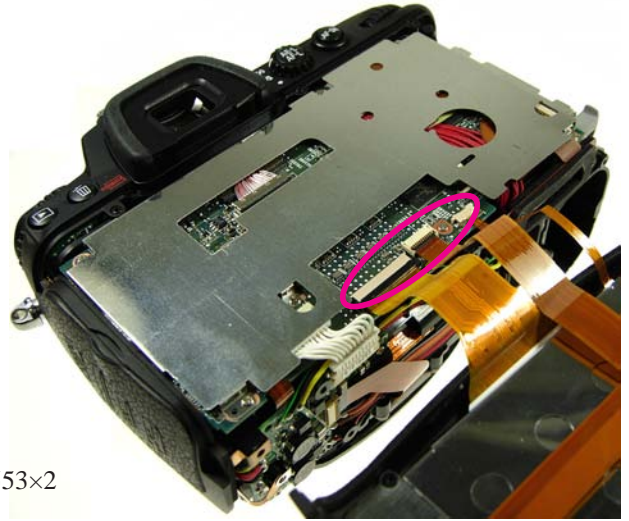

CF cover, sponge, other small parts

- Take out the two screws (#1518).

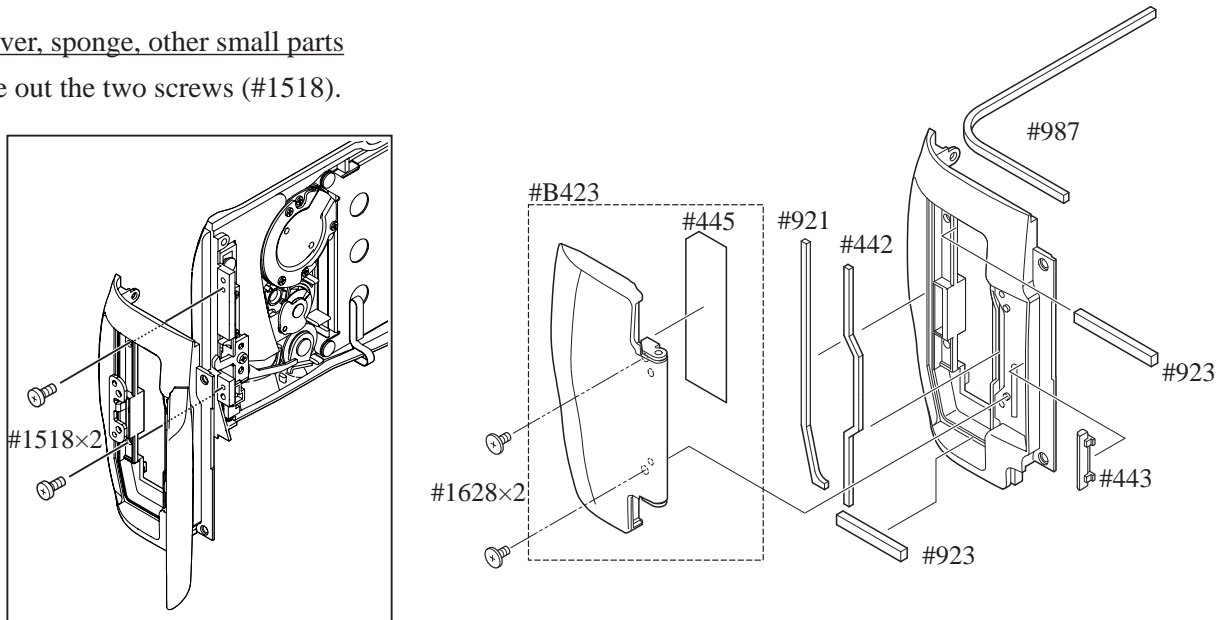

Rear SW FPC, Retainer plate, and other small parts

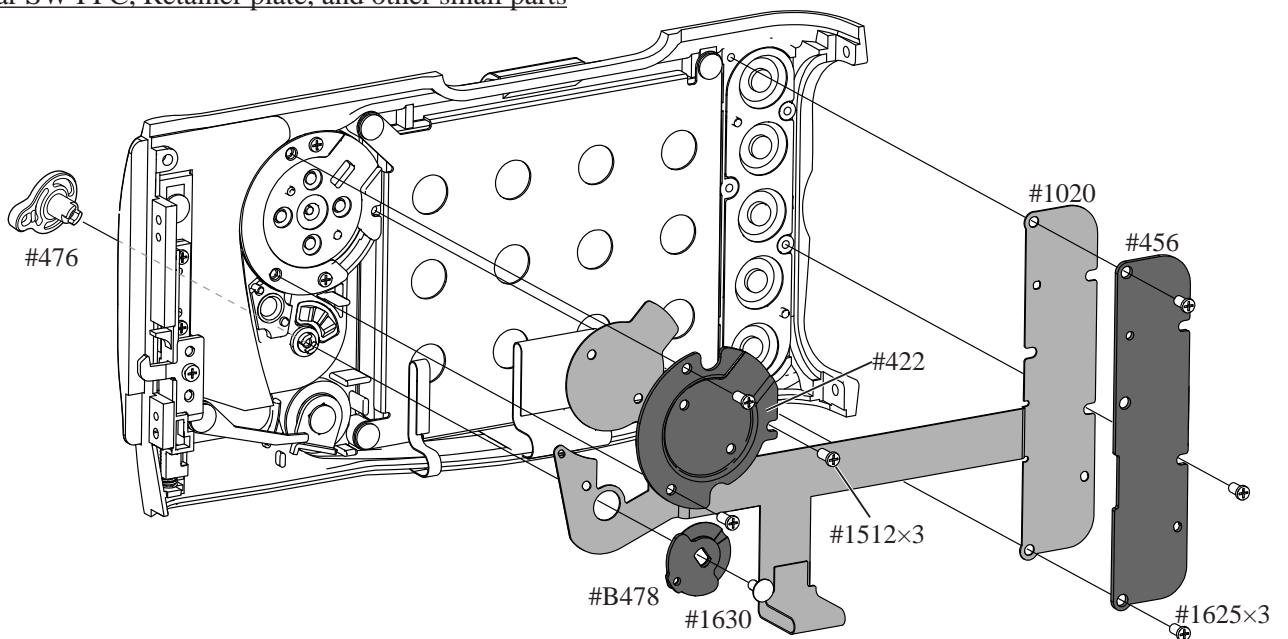

TFT monitor and other small parts

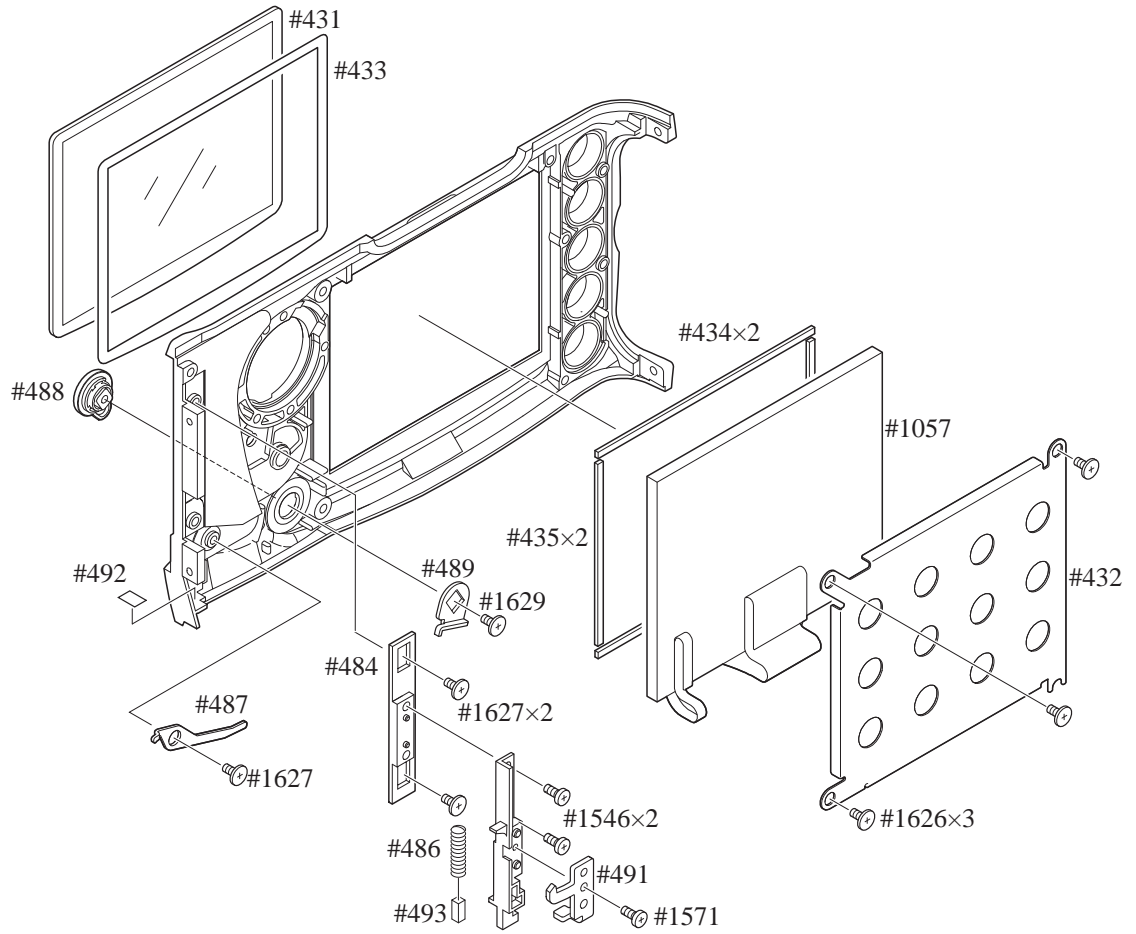

Selector button, Sponge, and other small parts

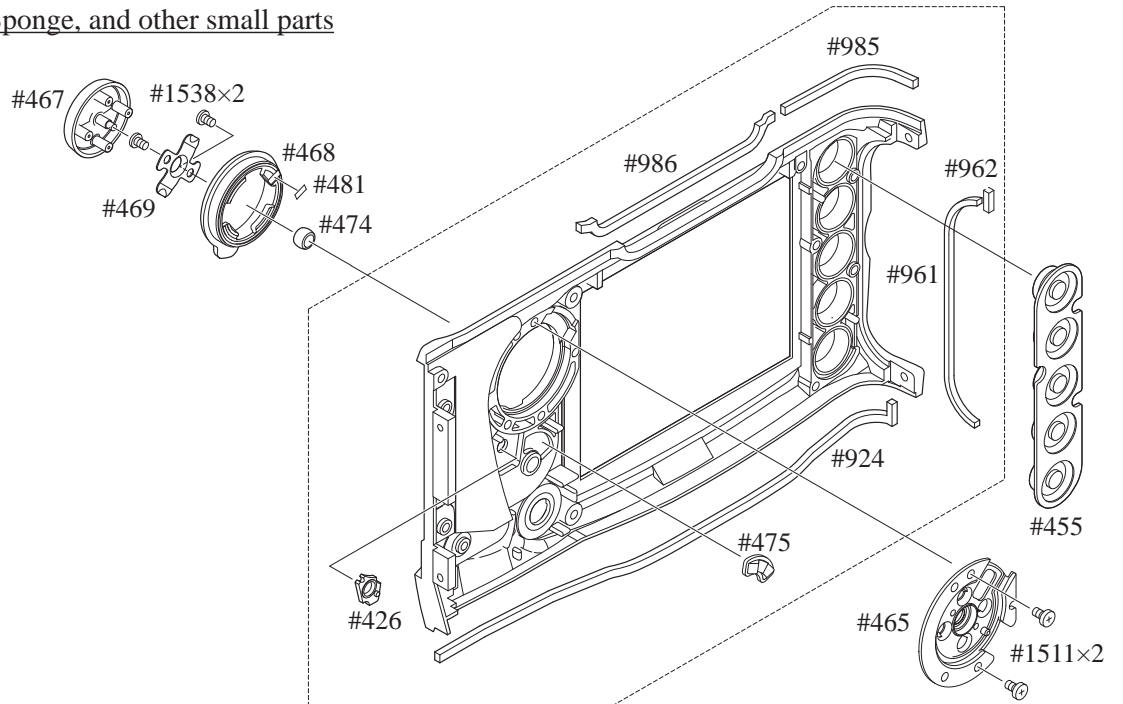

I/F cover

- Take out the two screws (#1510) and remove the I/F cover (#B28).
- Remove the conduct plate (#695).

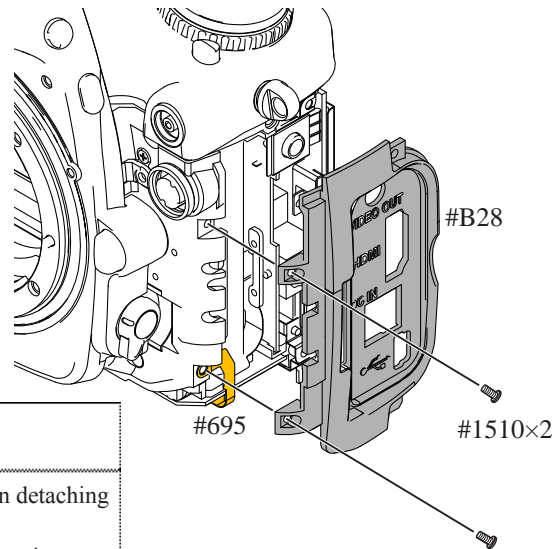

WARNING



- Take extra care not to get an electric shock when detaching covers.
- After removing covers, be sure to discharge the main condenser according to the instructions of repair manuals.

Discharge of Main condenser

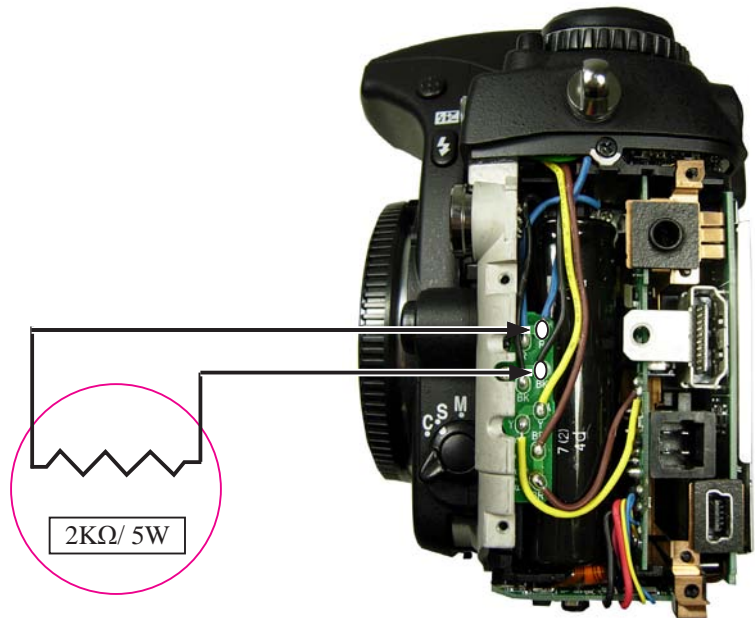

DG PCB shield plate

- Take out the four screws (#546) and two screws (#1515).
- Remove the two soldering bridges that joint DG-PCB and DG-PCB shield plate.
- Remove the DG-PCB shield plate.

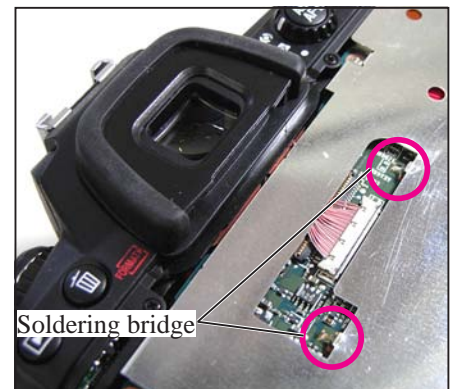
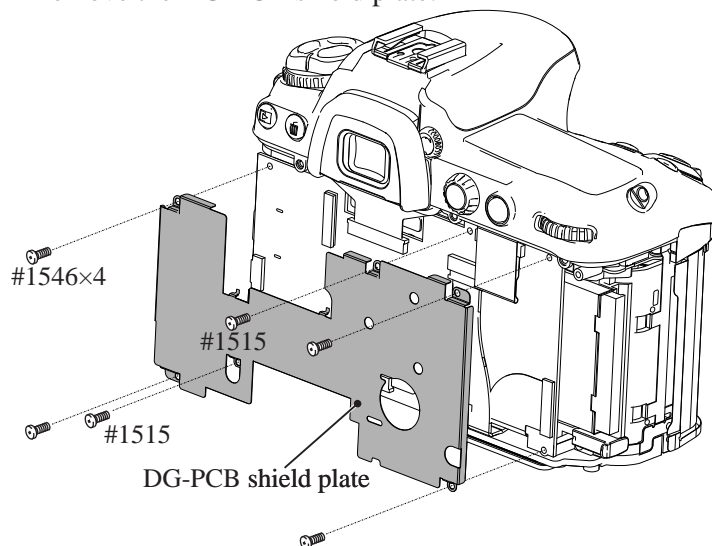

DG-PCB

- Remove the harnesses (#1075, #1074, and #1073) from each connector.
- Disconnect the FPC (#1027, #1040, #1041, #1039, #1038) from each connector.
- Take out the screw (#1546) and remove [#B1017].

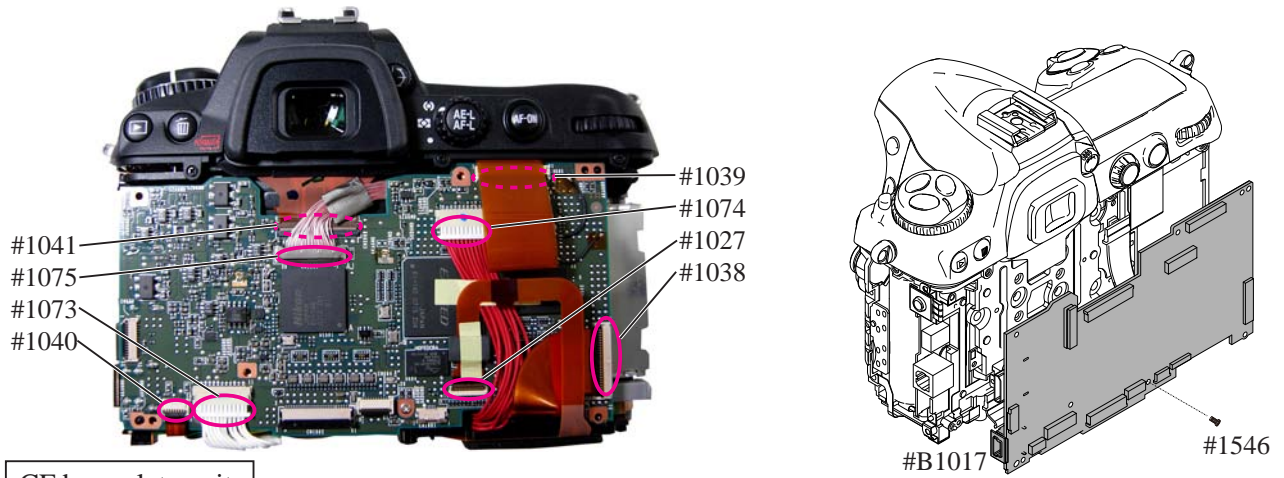

CF base plate unit

- Take out the three screws (#1543) and remove the CF base plate (#1018).

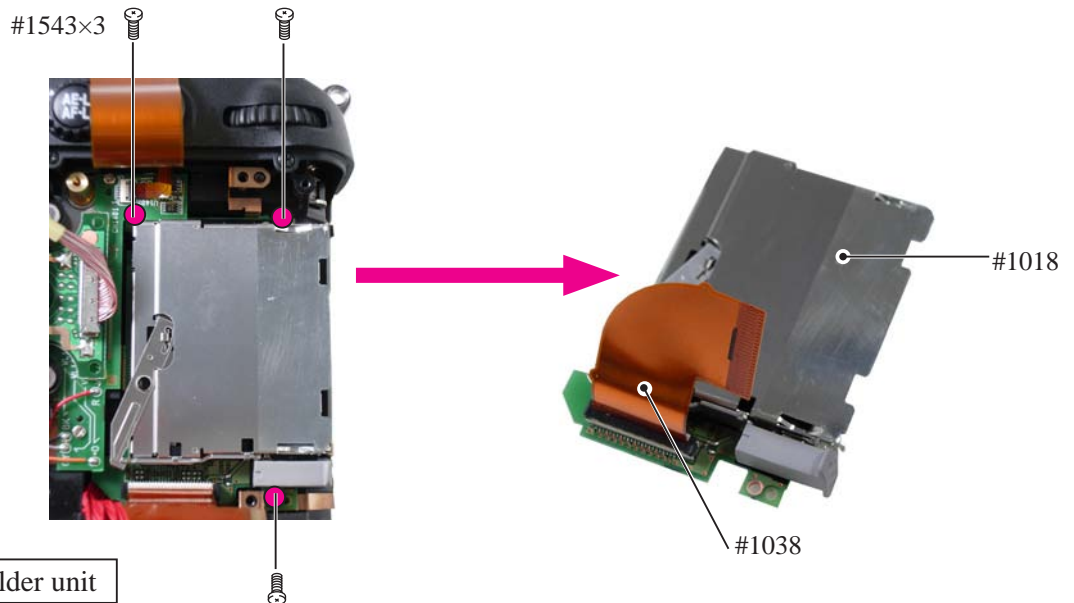
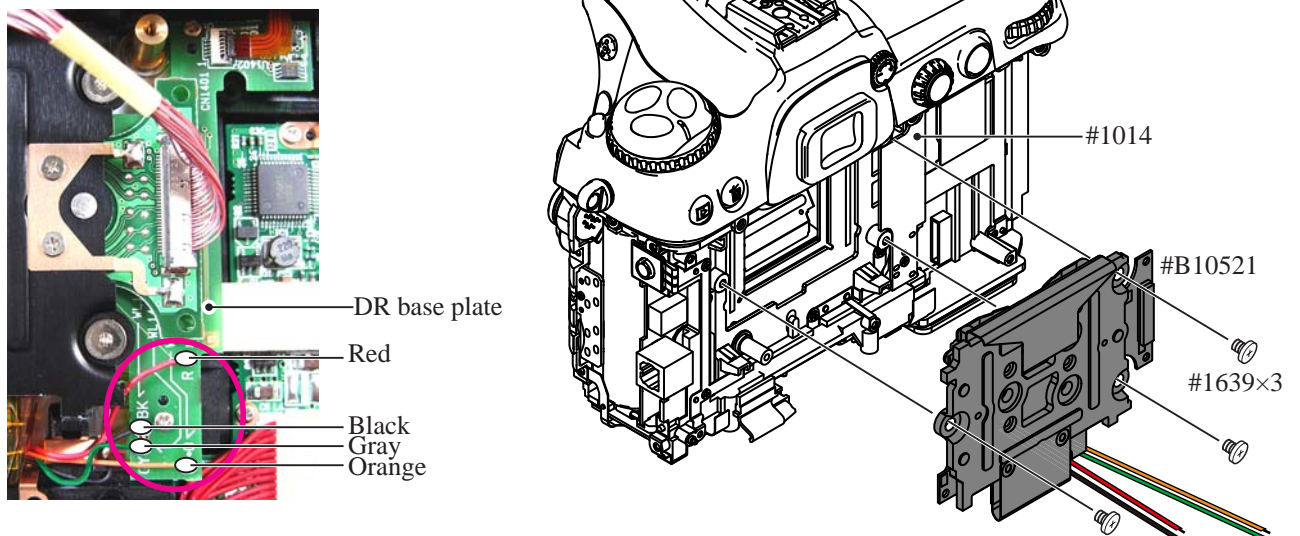

Image sensor holder unit

- Unsolder the DR base plate (#1014) at four places.
- Take out the three screws (#1639) and remove the image sensor holder unit (#B10521).



Top cover unit

Removal of Top cover

- Remove the dioptor-adjustment knob cover plate (#850), and take out the screw (#1622).
- Remove the dioptor-adjustment knob (#852), drip-proof sponge (#857) and drip-proof collar (#851).
- Raise the built-in speedlight, and take out the two screws (#1548), two screws (#1547), three screws (#1555) and two screws (#1511).
- Remove the four solders of the DI base plate (#1029).

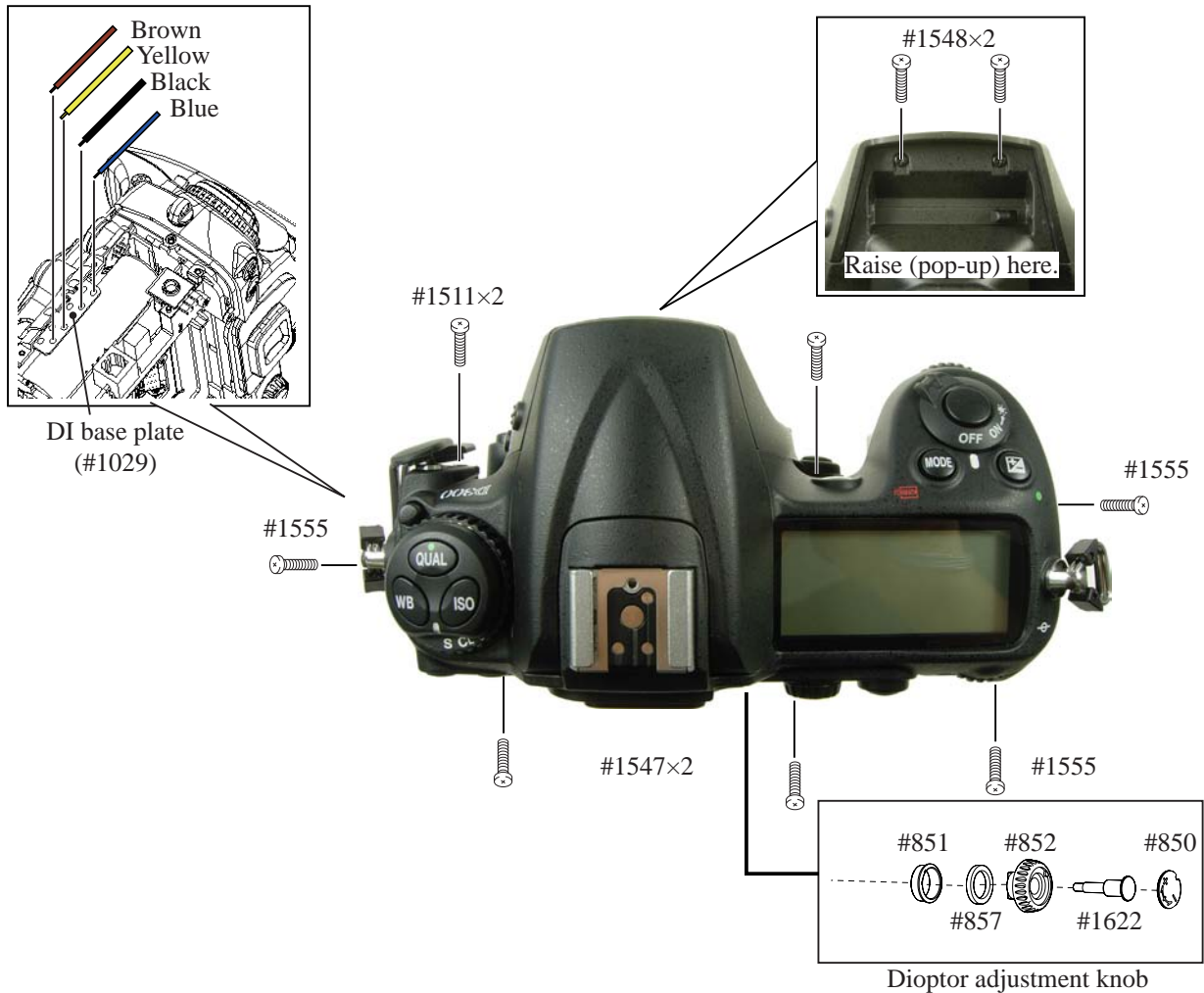

- Lift the top cover slowly so as not to cut the FPC, and disconnect the FPC from the connector.

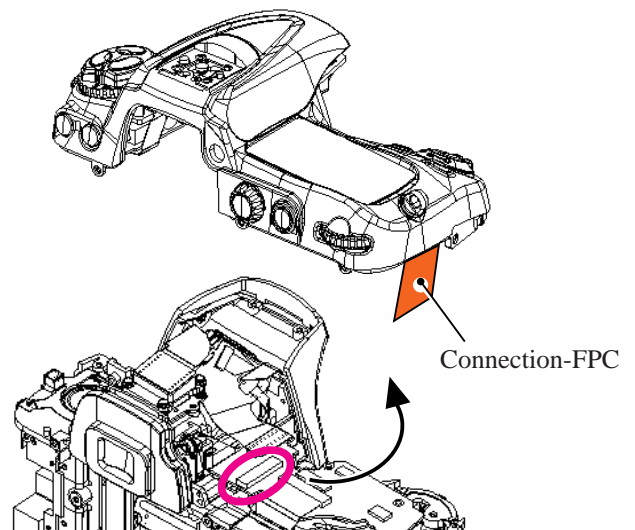

DR base plate and other small parts

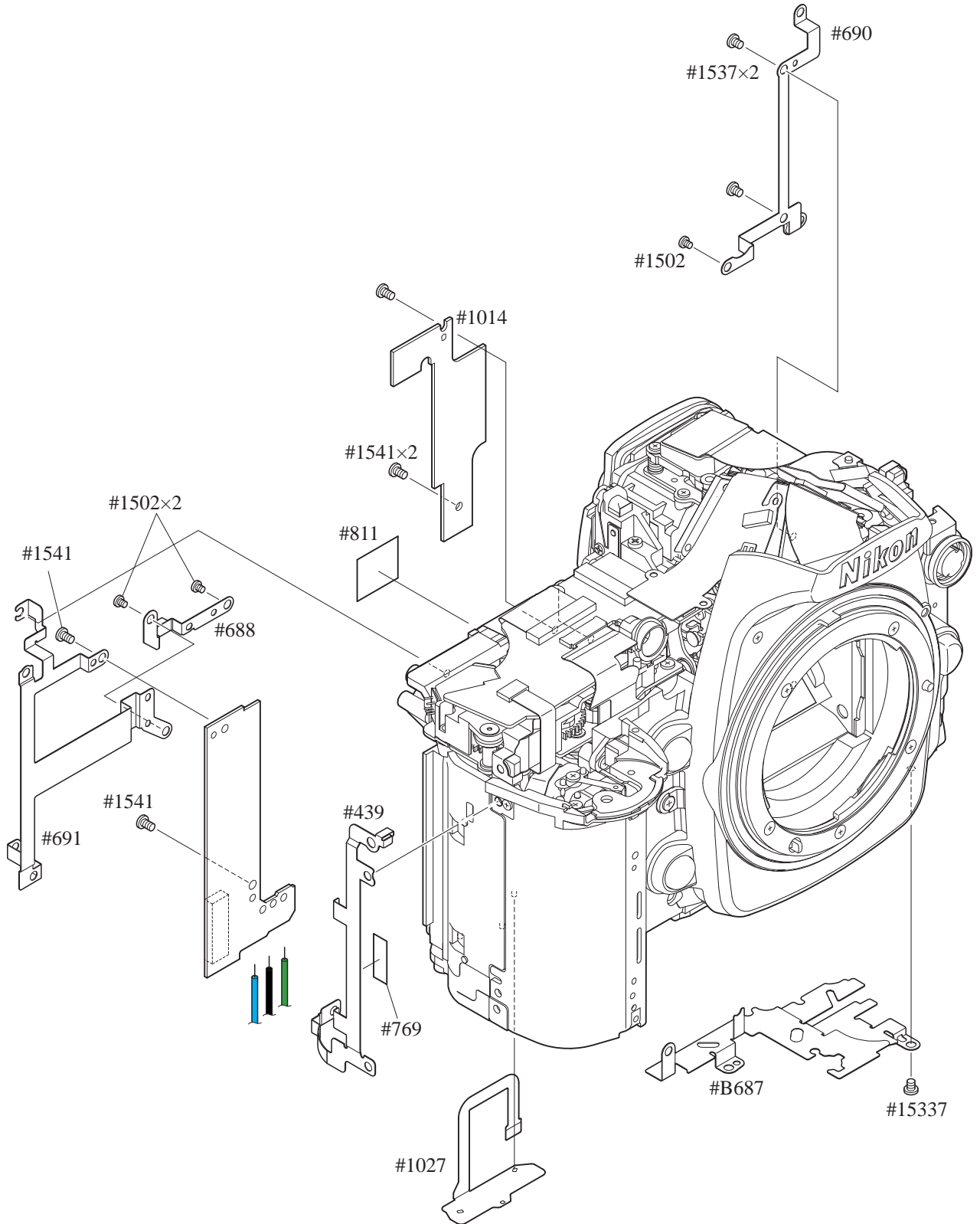

Command dial, Shoe base and other small parts

Shoe base

- Take out the four screws (#321).
- Remove the four solders of the shoe base.

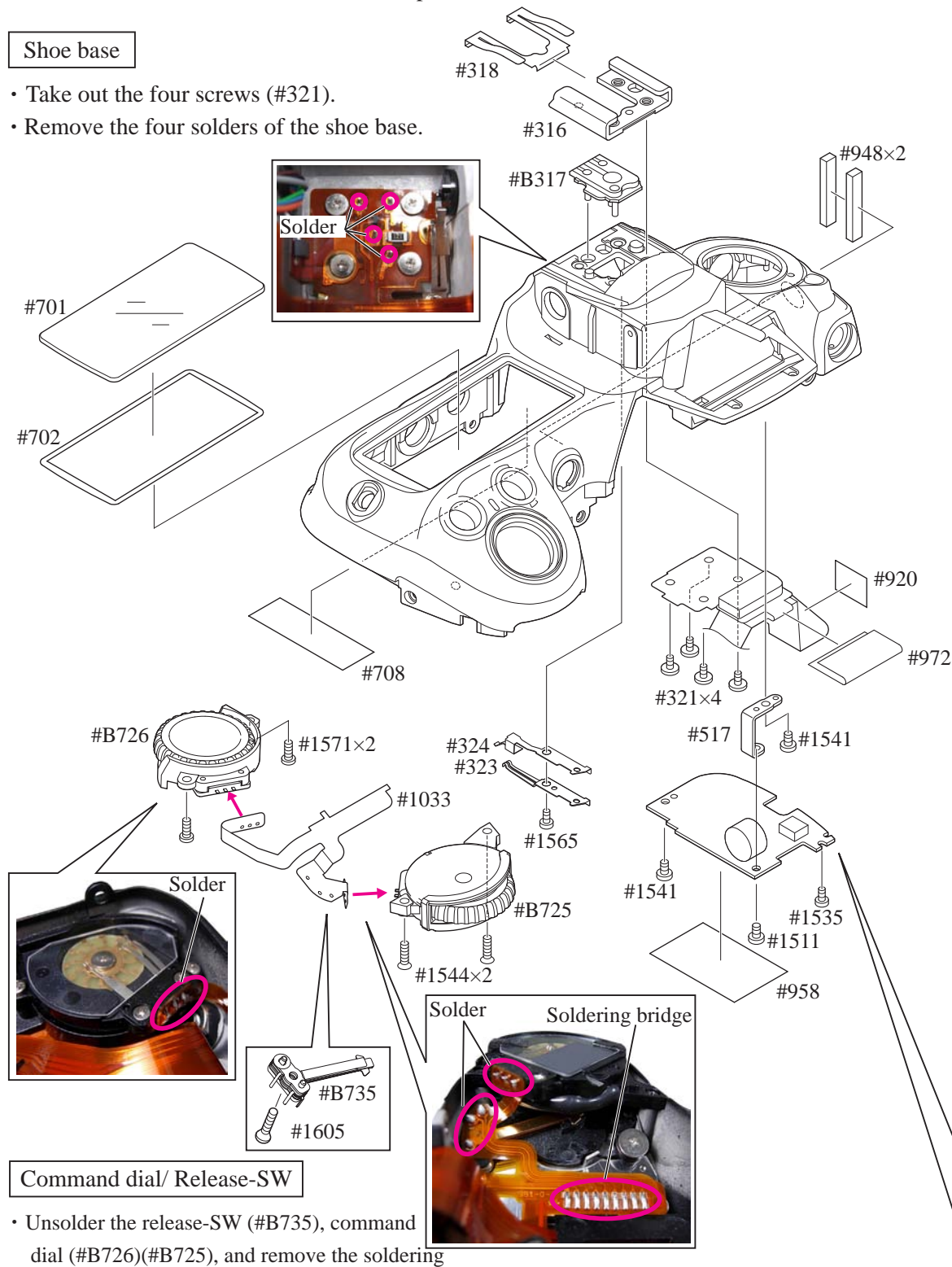

Command dial/ Release-SW

- Unsolder the release-SW (#B735), command dial (#B726)(#B725), and remove the soldering bridges, then remove the FPC (#1033).
- Take out the two screws (#1571) and two screws (#1544), and remove the command dial.
- Take out the screw (#1605) and remove the release-SW.

SB-PCB

- Disconnect the FPC from the connector.
- Unsolder the six SB wires of SB flash unit and the wire of the synchro-terminal.
- Take out the screws (#1511, #1535, and #1541), and remove the SB-PCB.

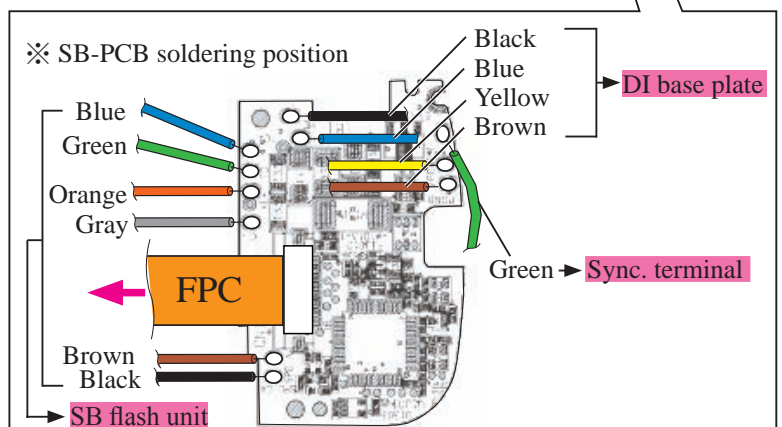

Outside LCD, Release SW and other small parts

Outside LCD/FPC

- Unsolder the three wires .
- Take out the screw (#1606) and remove the spring (#750).
- Take out the two screws (#1547), three screws (#1544), two screws (#1540) and one screw (#1560).
- Remove the power plate (#747), outside LCD frame (#703), Compensation/mode button support plate (#731).
- Disconnect the mode dial FPC from the connector, and remove the outside LCD FPC (#1003).

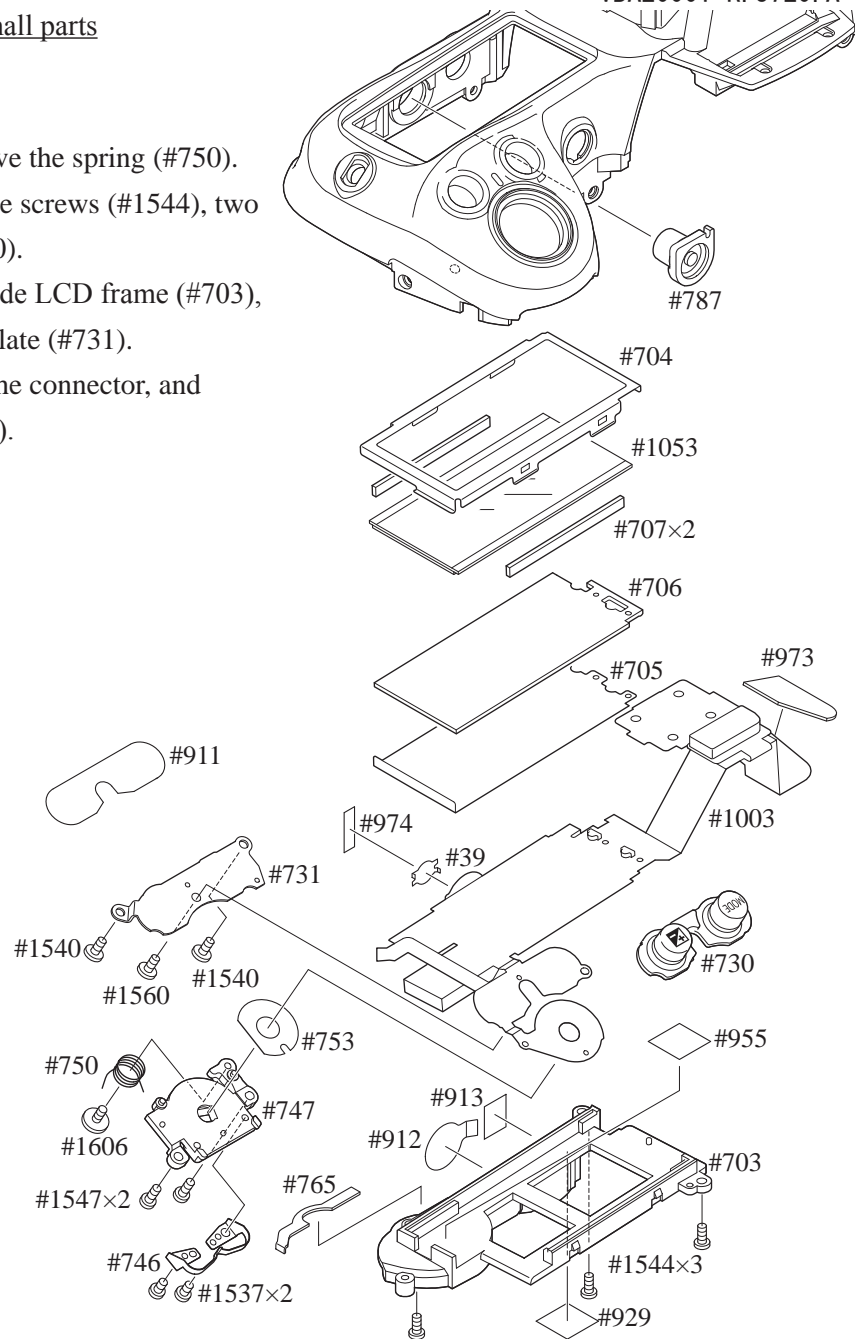
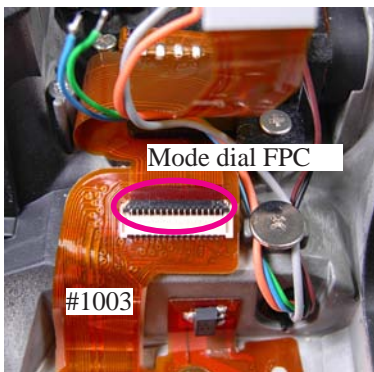
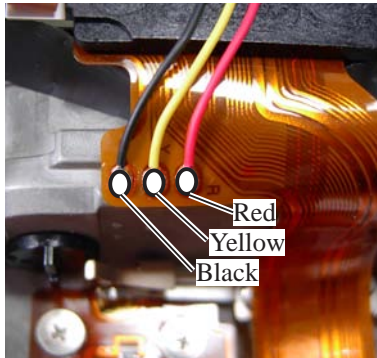

Metering mode dial, Power dial and other small parts

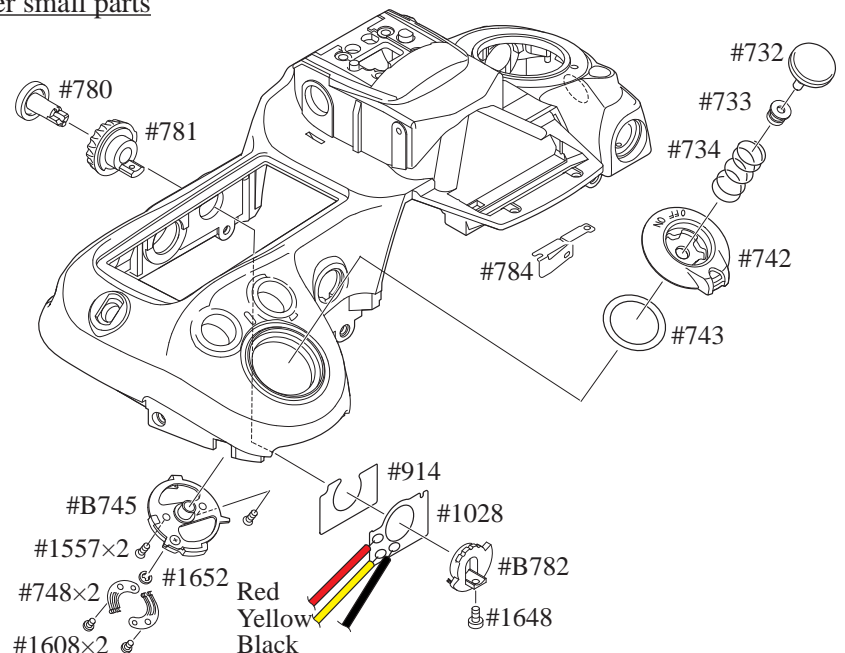

SB case, Synchro-terminal and other small parts

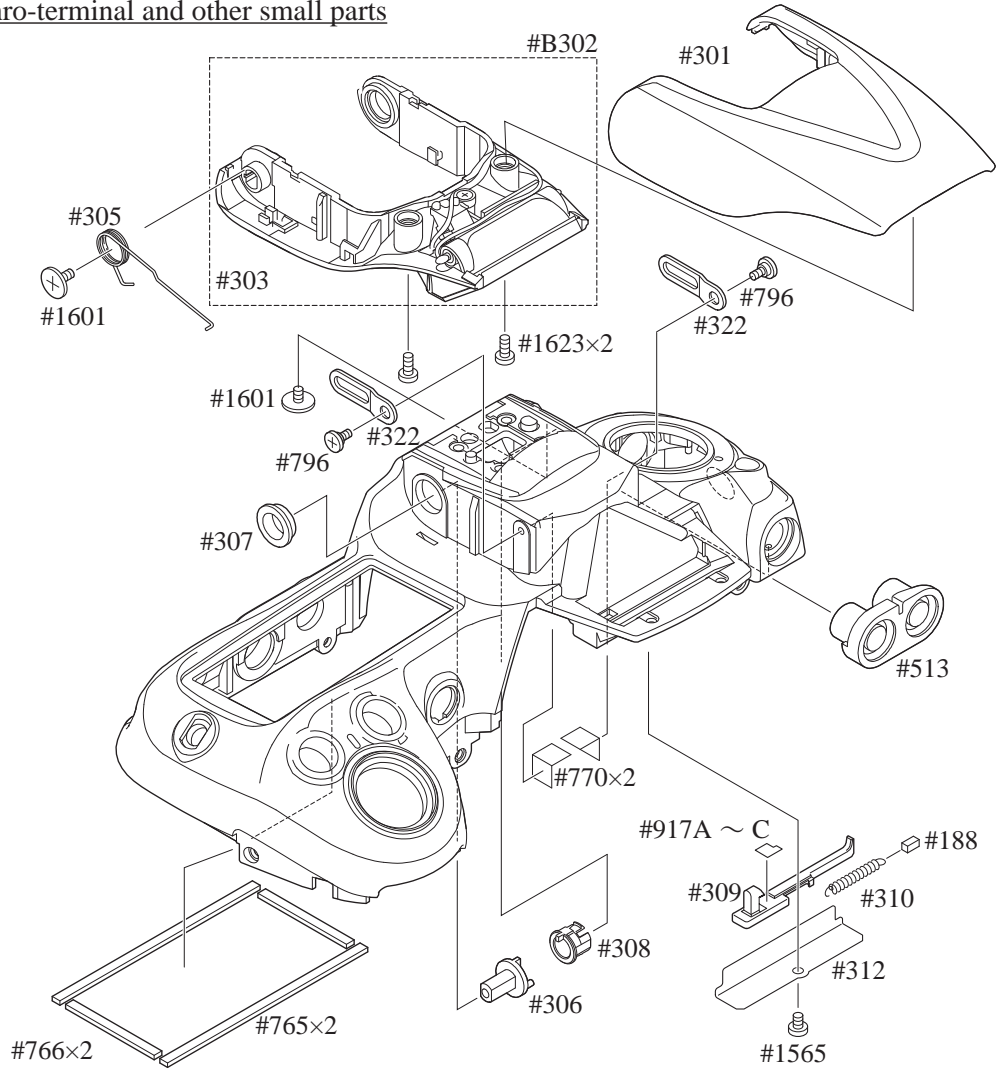

Mode dial, Eyelet and other small parts

Mode dial / Trefoil button

- Remove the soldering bridges of the FPC (#1025) and [#1026].
- Take out the screw (#1574) and remove the mode dial unit (#B504) and the trefoil button unit (#B502).

Synchro-terminal

- Unsolder the synchro-terminal lead wire (#1107).
- Take out the screw (#1532) and remove the synchro terminal (#50).

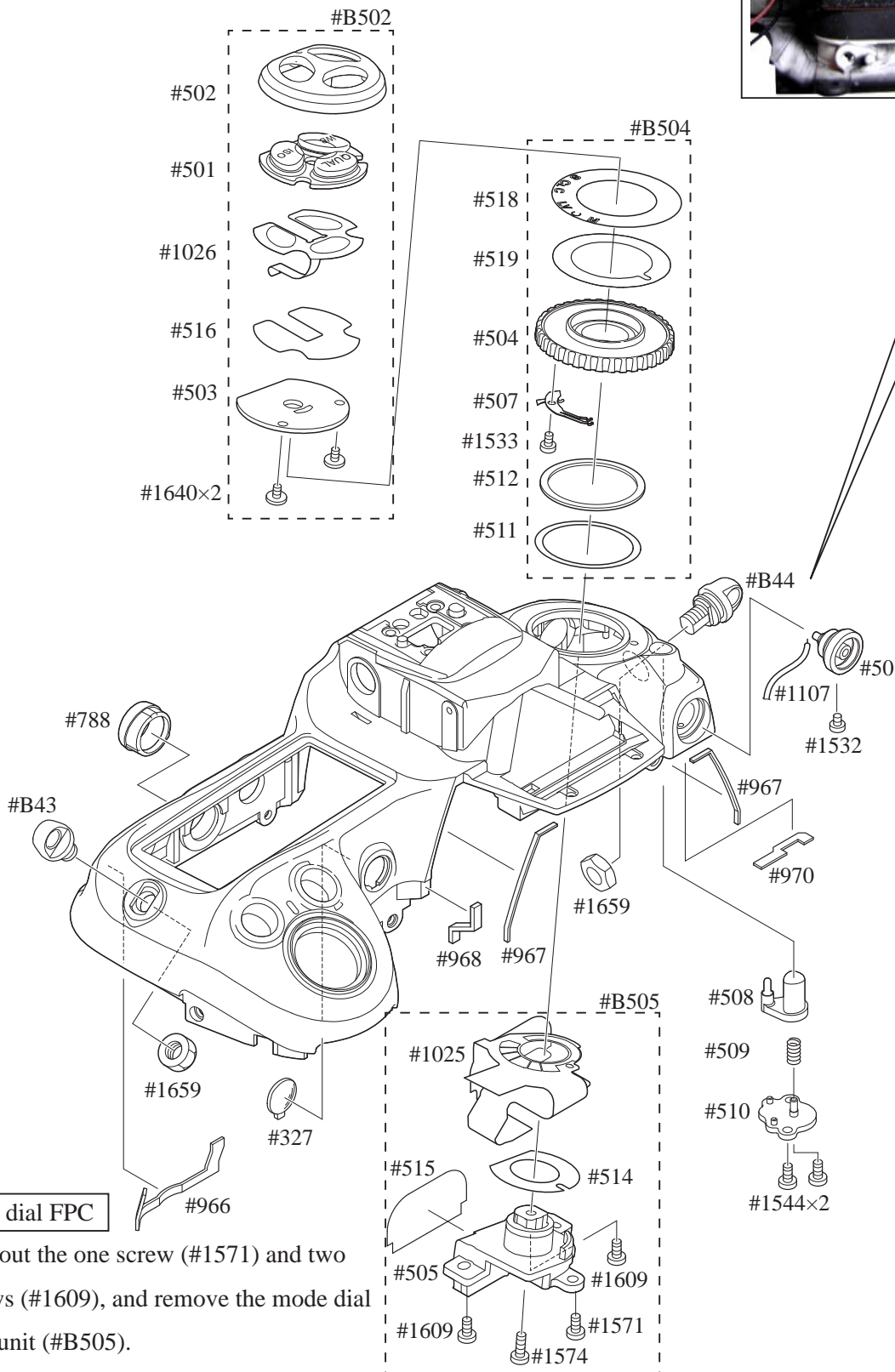
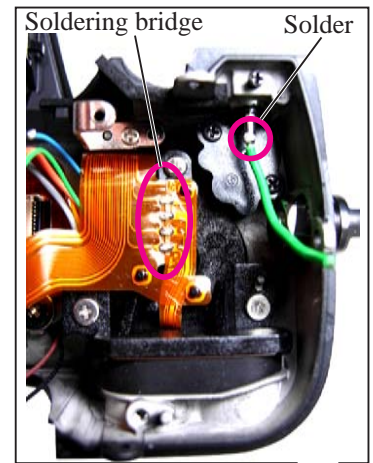

Mode dial FPC

- Take out the one screw (#1571) and two screws (#1609), and remove the mode dial FPC unit (#B505).

Main PCB unit

- Remove the five solders of the main PCB (#1001).
- Disconnect the FPCs (#1030, #1009, #1005) and the shutter-FPC from each connector.
- Take out the three screws (#1616), and remove the main PCB (#B1001) and the conduction lug plate (#775).

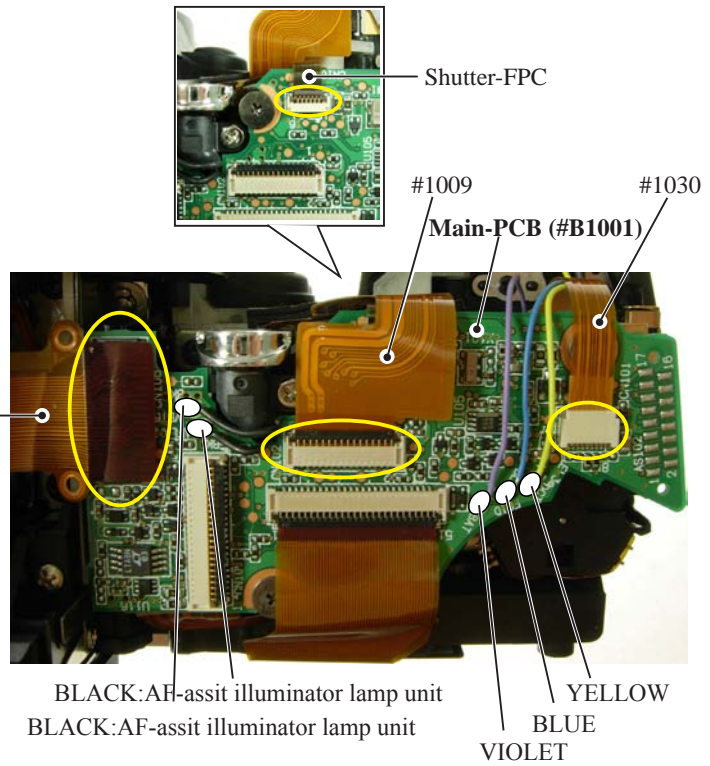

※ Remove the two solders of the buzzer wires from the FPC (#B1005).

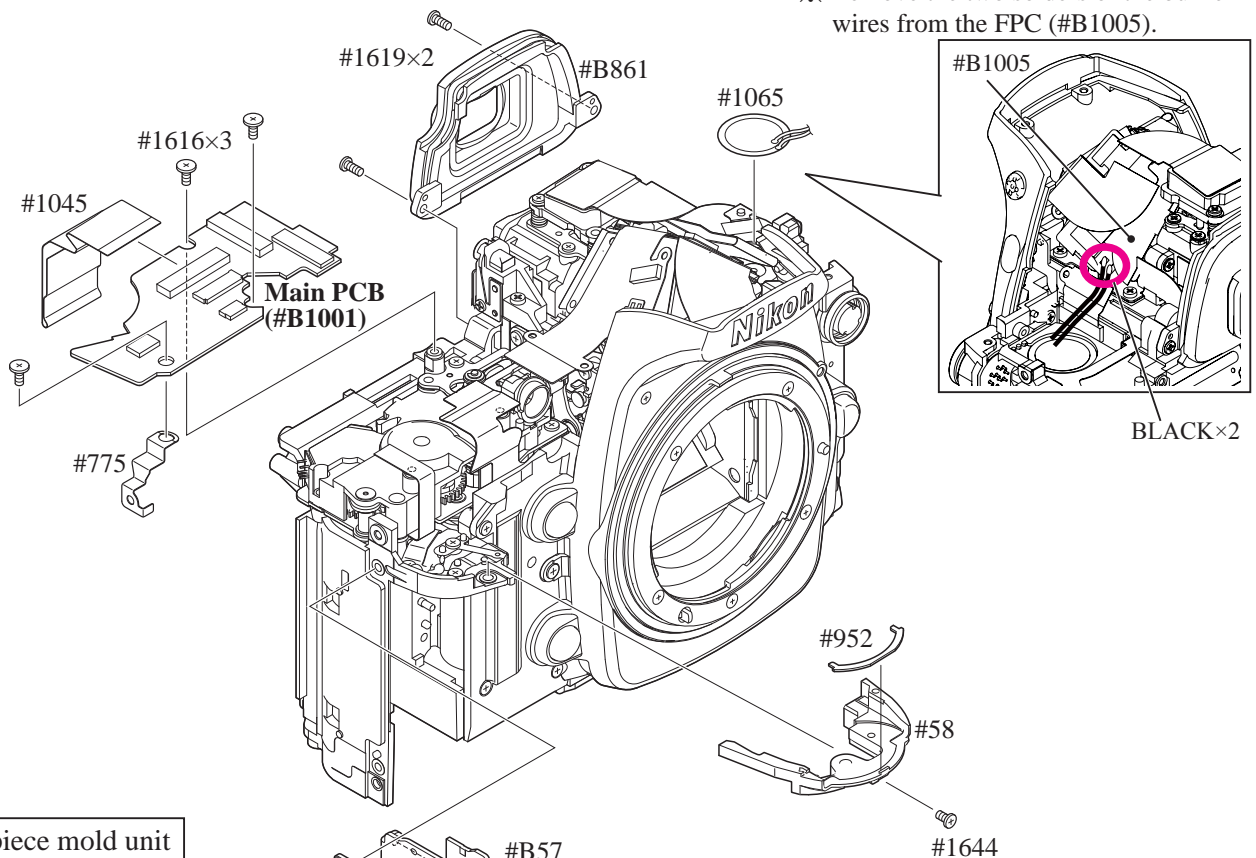

Eyepiece mold unit

- Take out the two screws (#1619).
- Remove the eyepiece mold unit (#B861).

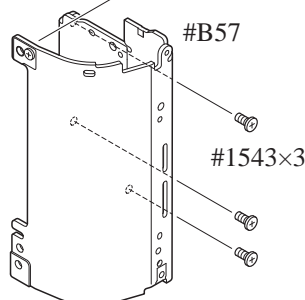

2. Separation of Front body from Rear body

- Remove the FPC (#1042) from the connector.
- Take out the six screws (#1575), one screw (#1525), one screw (#1572), and two screws (#1531).
- Remove the front body from the rear body.

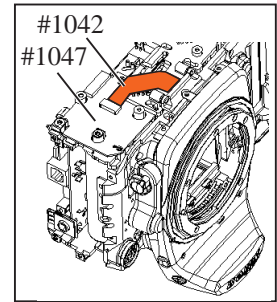

Dioptor adjustment gear case

- Take out the screw (#1526) and remove the dioptor adjustment gear case (#B855).

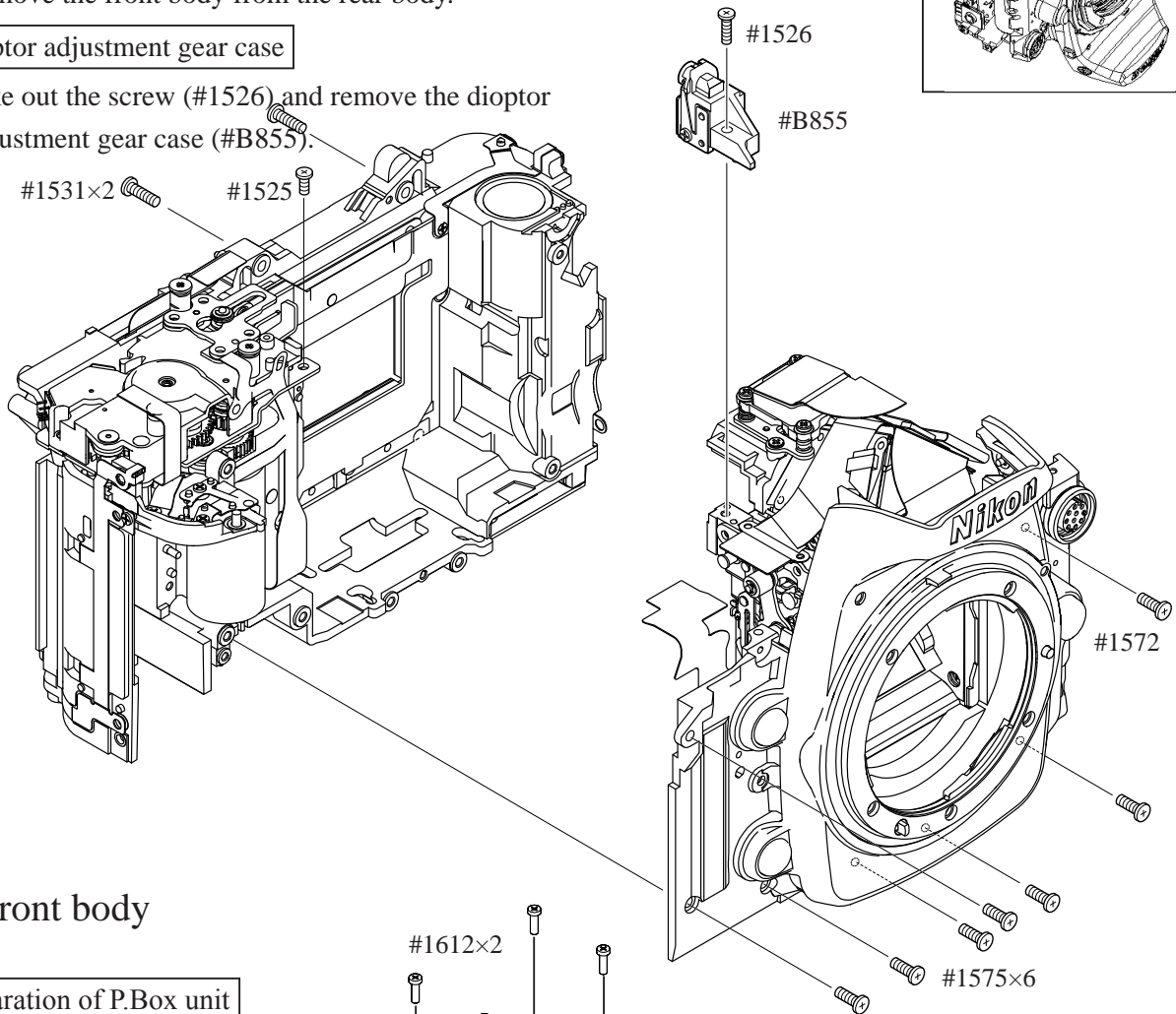

3. Front body

Separation of P.Box unit

- Disconnect the two FPCs from each connector.
- Take out the four screws (#1612).
- Remove the P.Box unit (#B831).

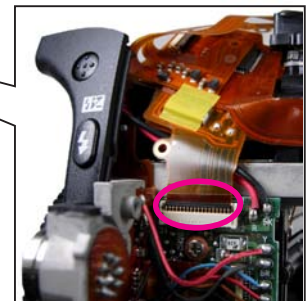
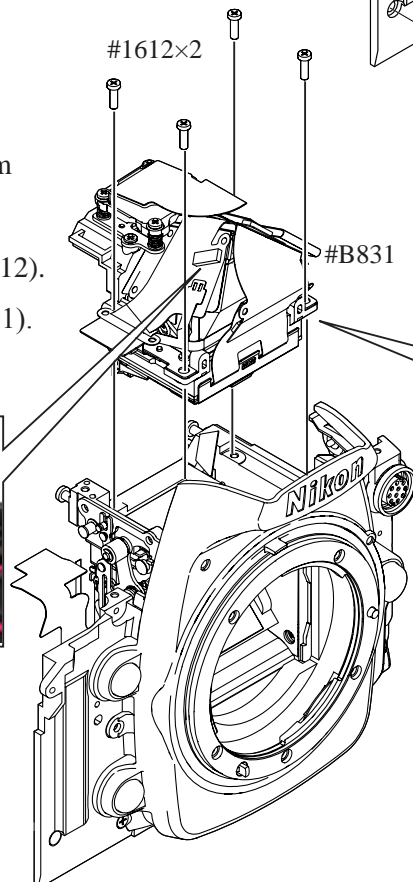
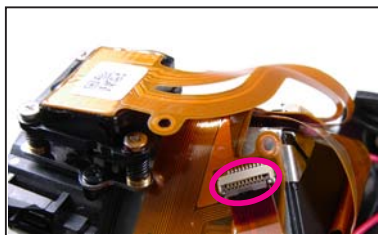

AE FPC unit

- Disconnect the FPC from the connector.
- Take out the three screws (#1617).
- Remove the AE FPC unit.

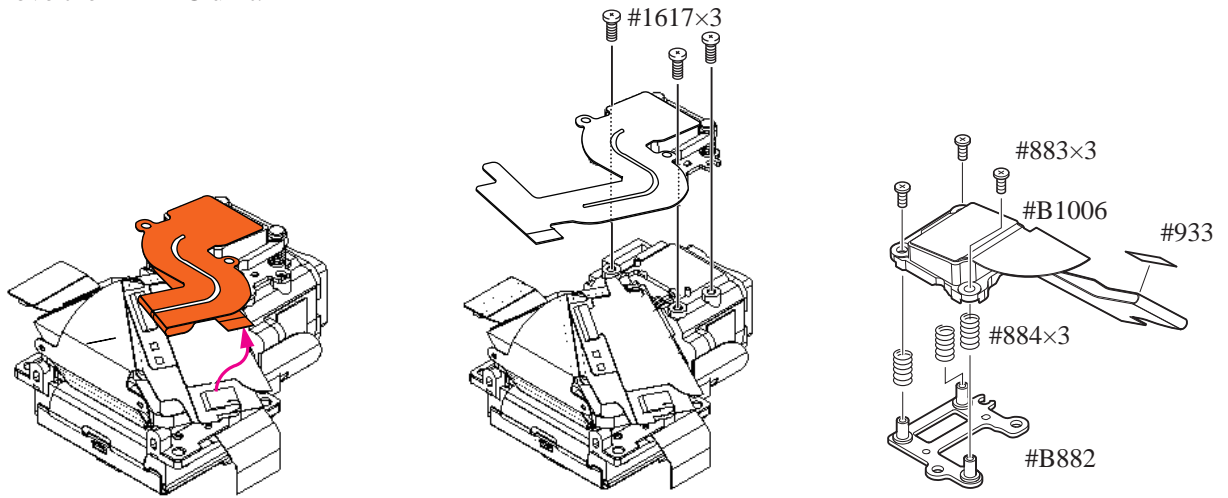

Eyepiece block unit

- Peel off the eyepiece lower dustproof tape (#909).
- Take out the two screws (#1619) and remove the eyepiece block unit.

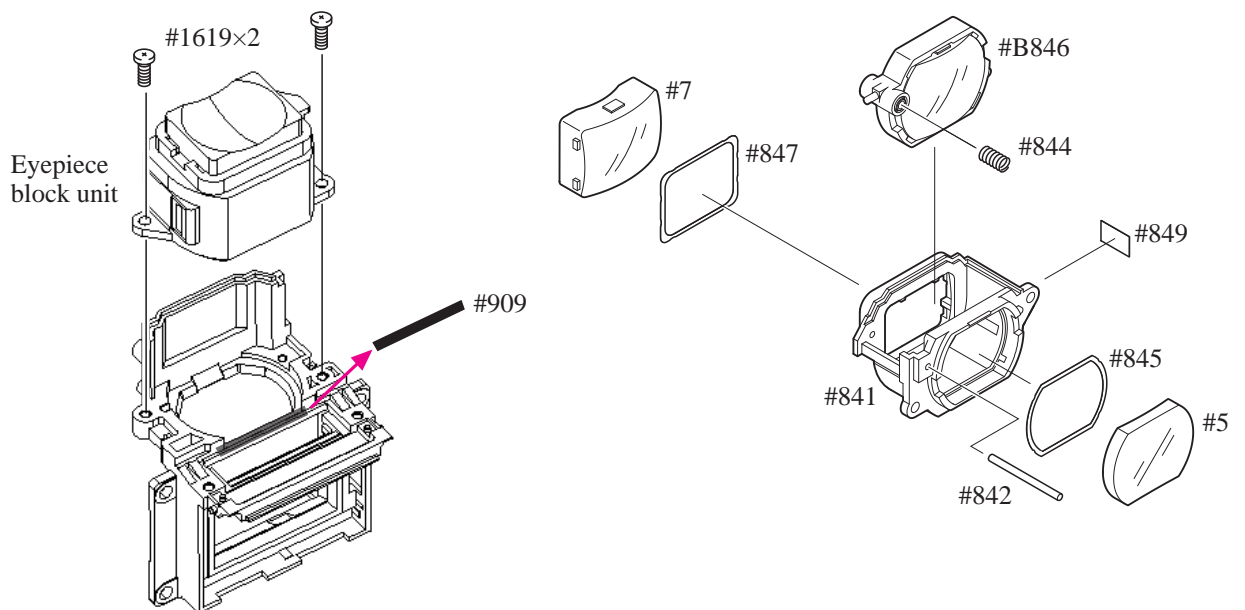

P.Box unit

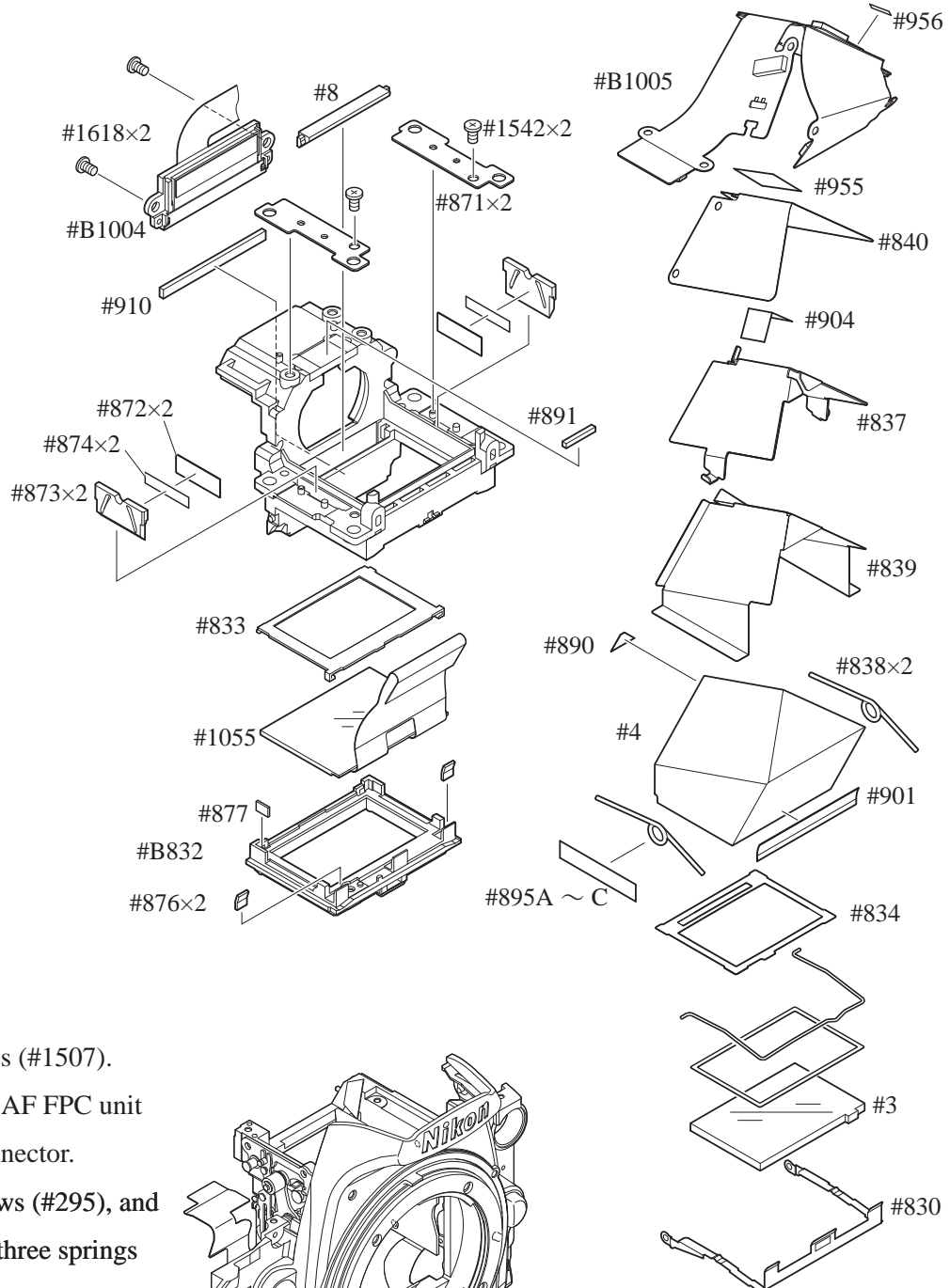

AF FPC unit

- Take out the two screws (#1507).
- Disconnect the FPC of AF FPC unit (#B1007) from the connector.
- Take out the three screws (#295), and remove [#B1007] and three springs (#293).

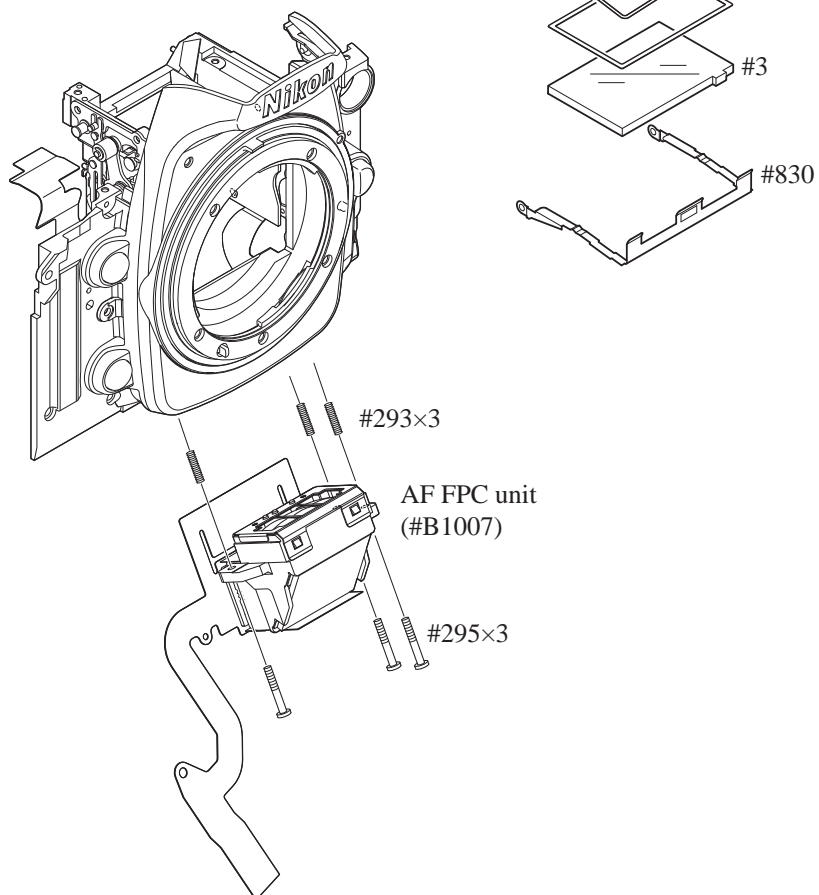
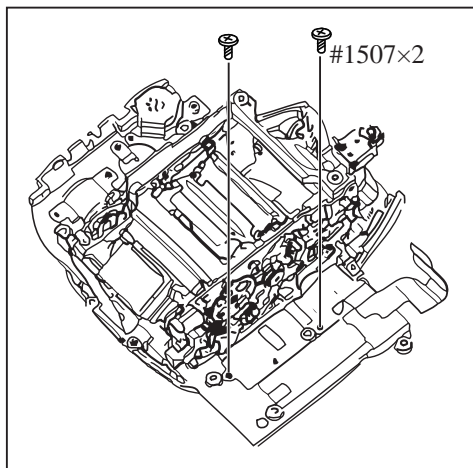

PD base plate/10-pin terminal

- Remove the ten solders of the wires that are connected to the PD base plate (#1002).
- Disconnect the FPC (#1010) from the connector.
- Take out the screw (#1522), and remove the PD base plate.
- Remove the solder of the lens release SW lug plate (#680) and also remove nine solders of the 10-pin terminal (#41) (which is assembled from the other side and soldered).
- Take out the screw (#1503), and remove [#680] and the FPC (#1010).
- Take out the screw (#65), and remove [#41].

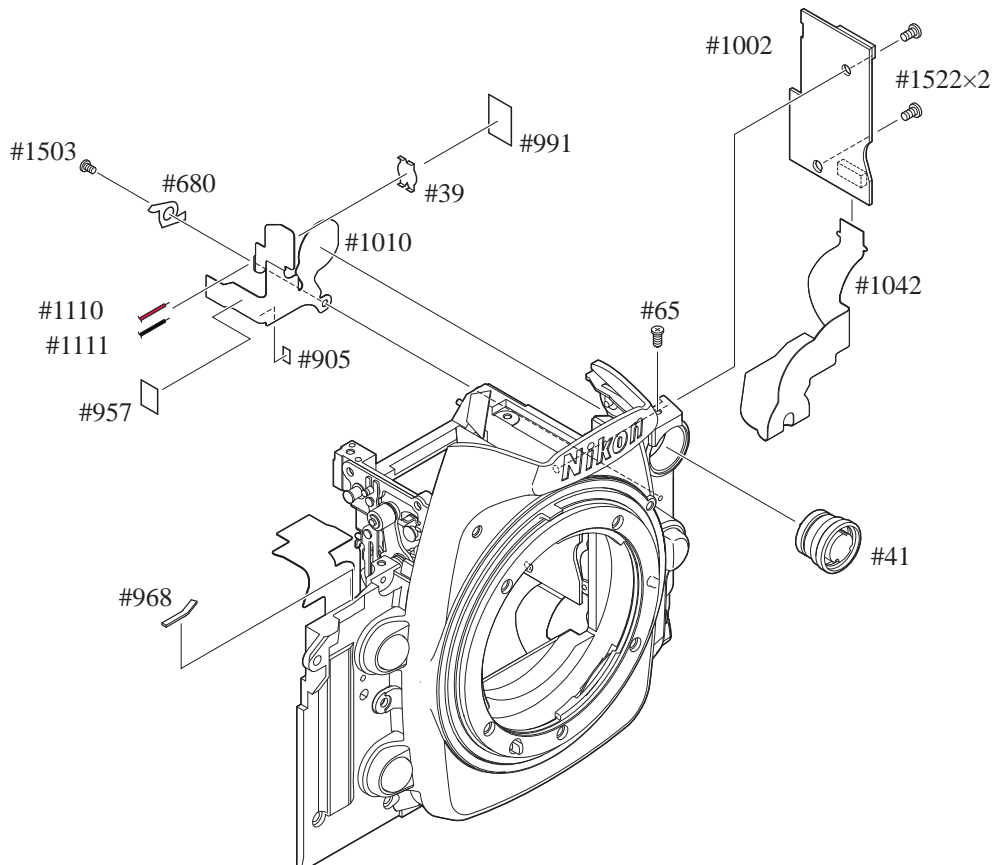
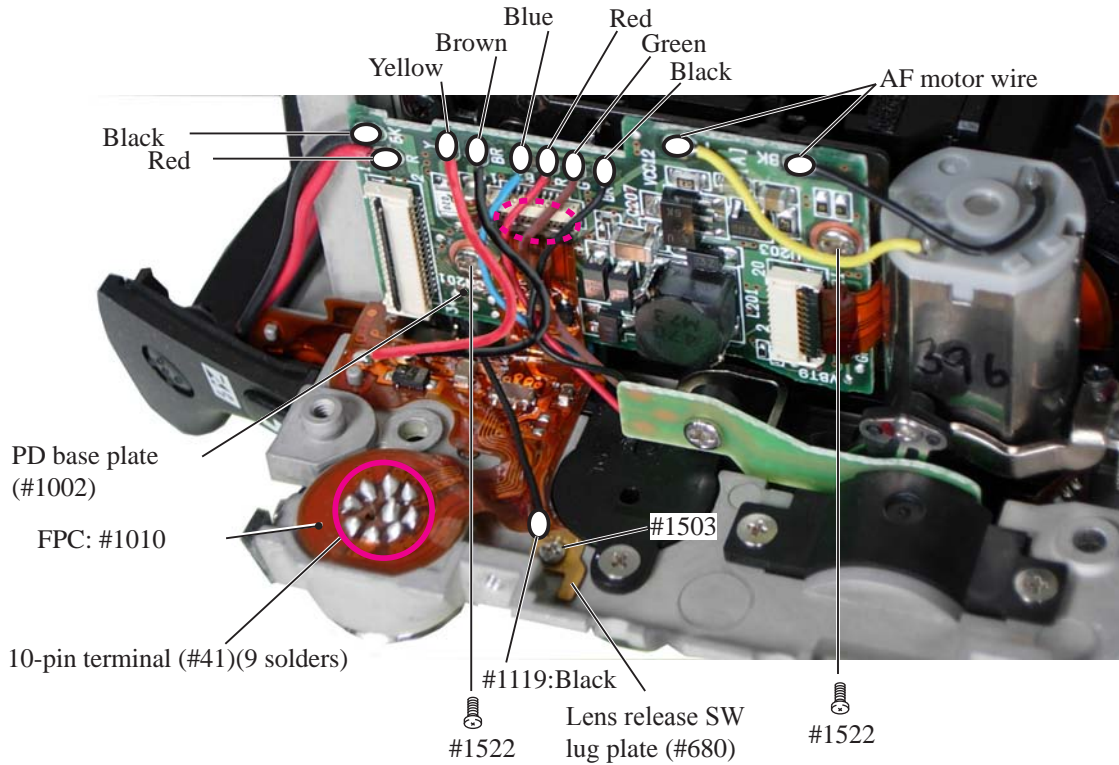

Front cover, Bayonet and other small parts

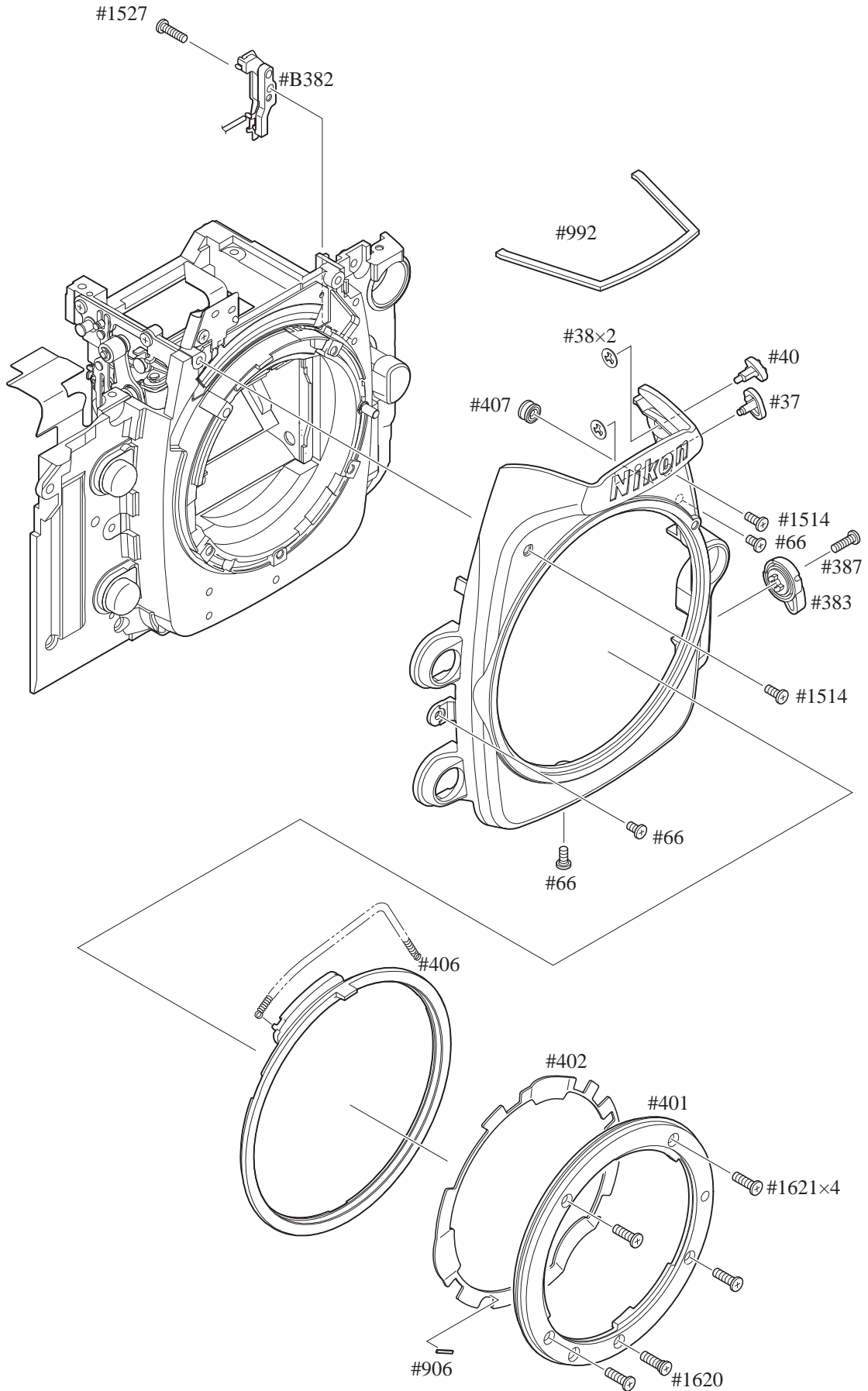

Mirror box, I base plate, Release base unit and other small parts

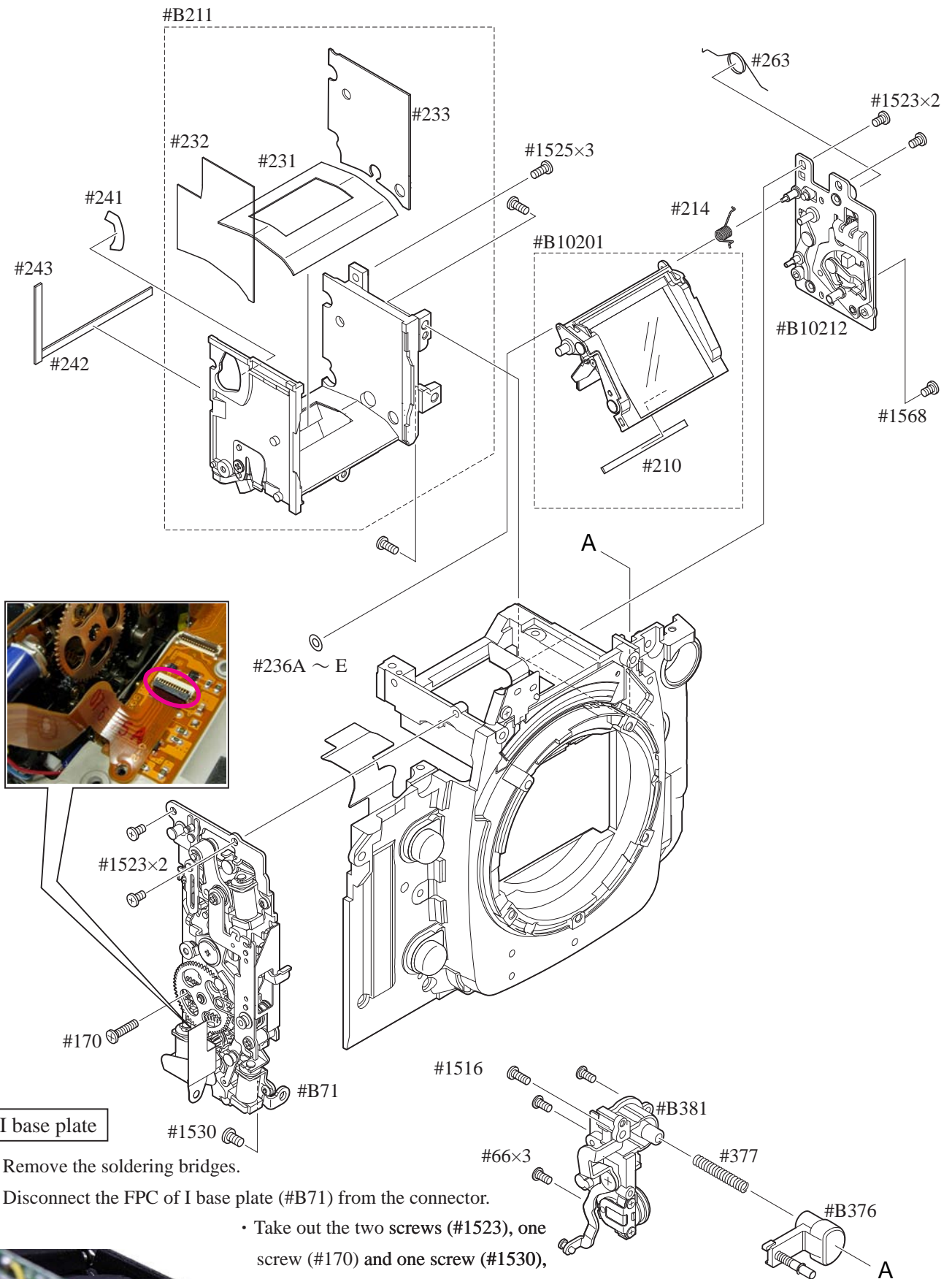

I base plate

- Remove the soldering bridges.
- Disconnect the FPC of I base plate (#B71) from the connector.
 - Take out the two screws (#1523), one screw (#170) and one screw (#1530), and remove the I base plate.

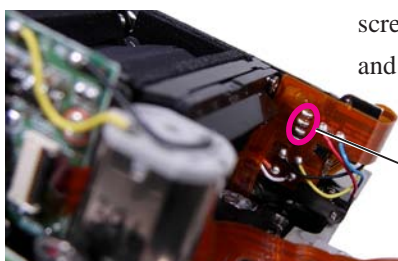

Soldering bridge (which joints AF-drive FPC and I-base plate FPC)

AF drive section, P/F button, Lens contact, and other small parts

Lens contact

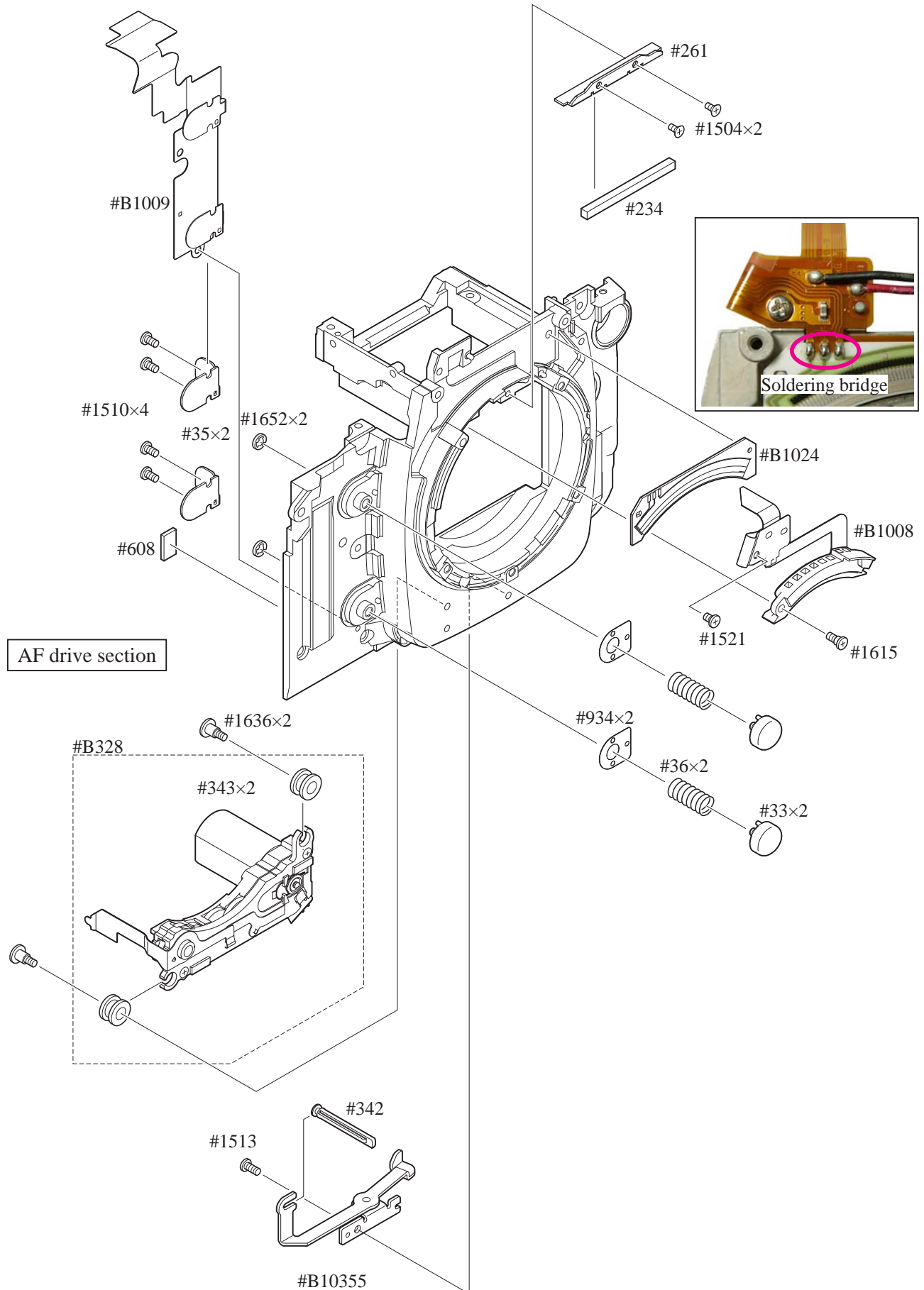

AF drive section

4. Rear body

Charge-base plate, I/F base plate, Main condenser and other small parts

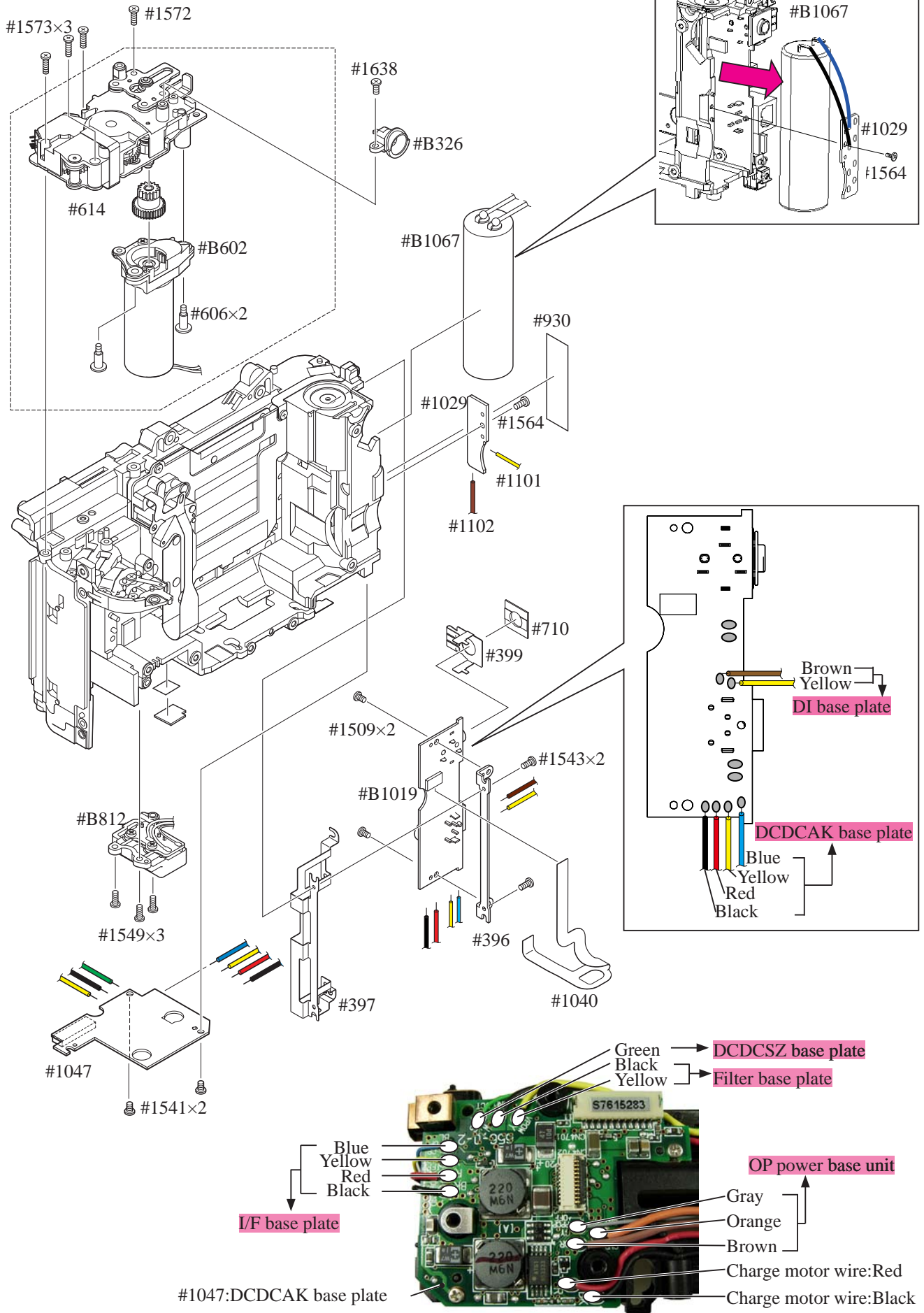

Shutter unit

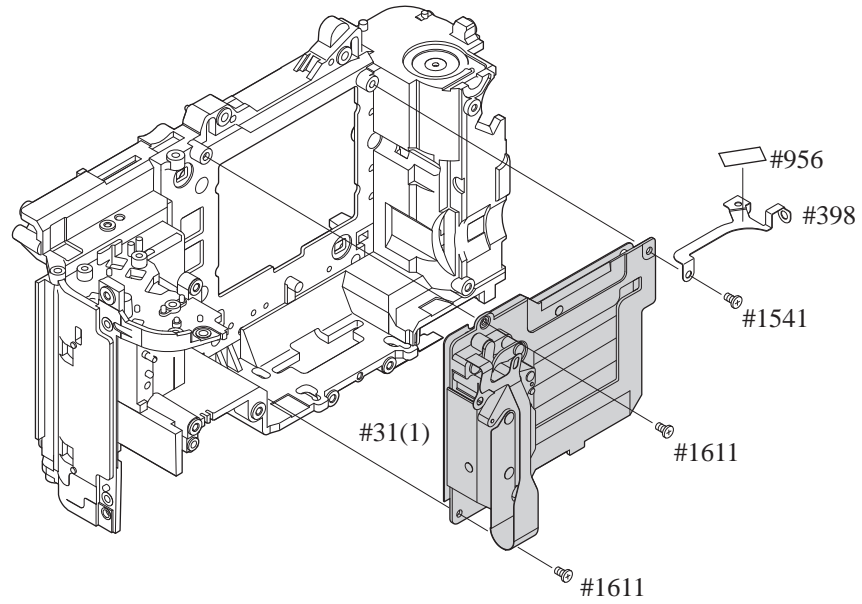

Rear Body

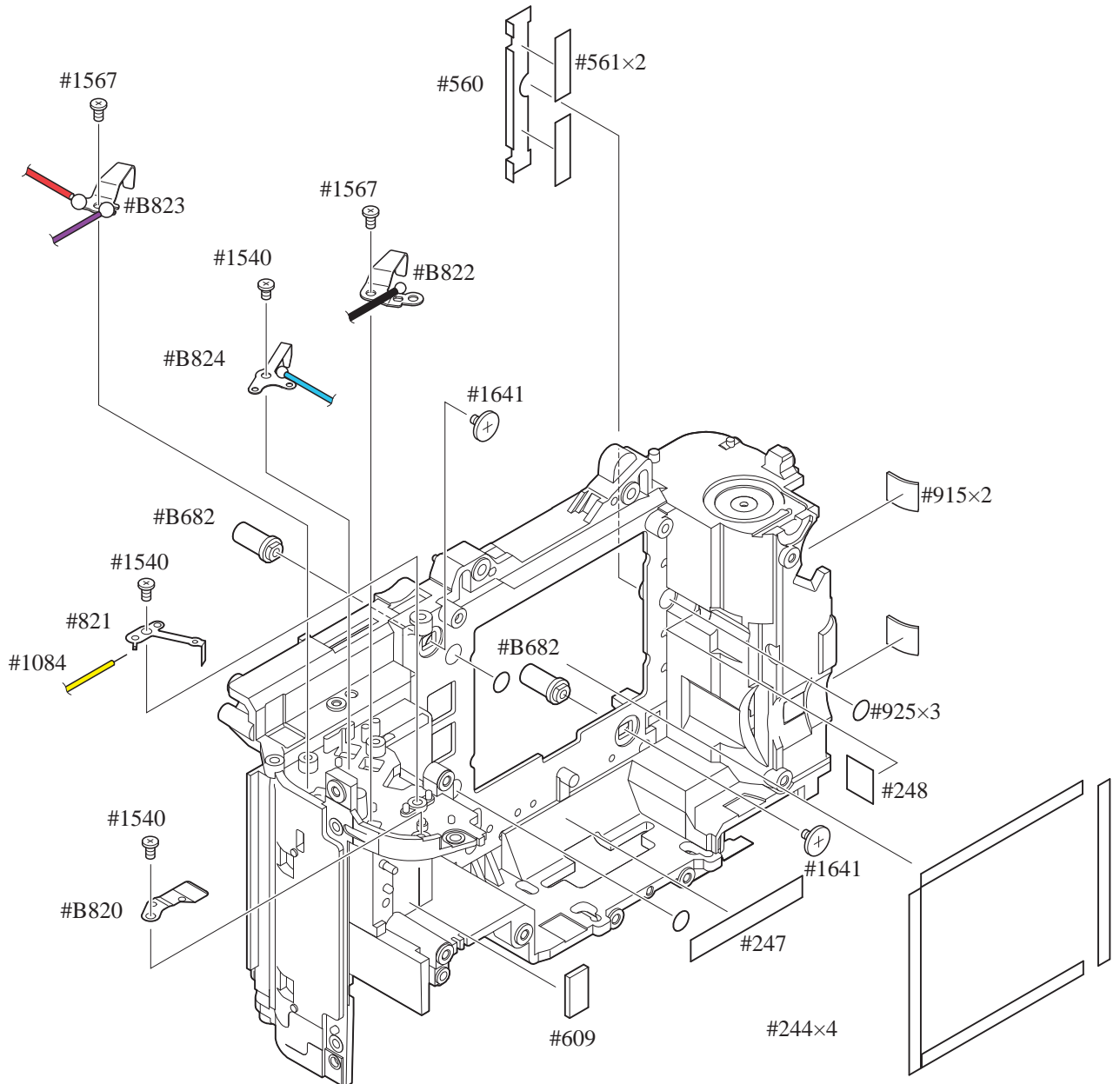

Assembly / Adjustment

1. Rear body

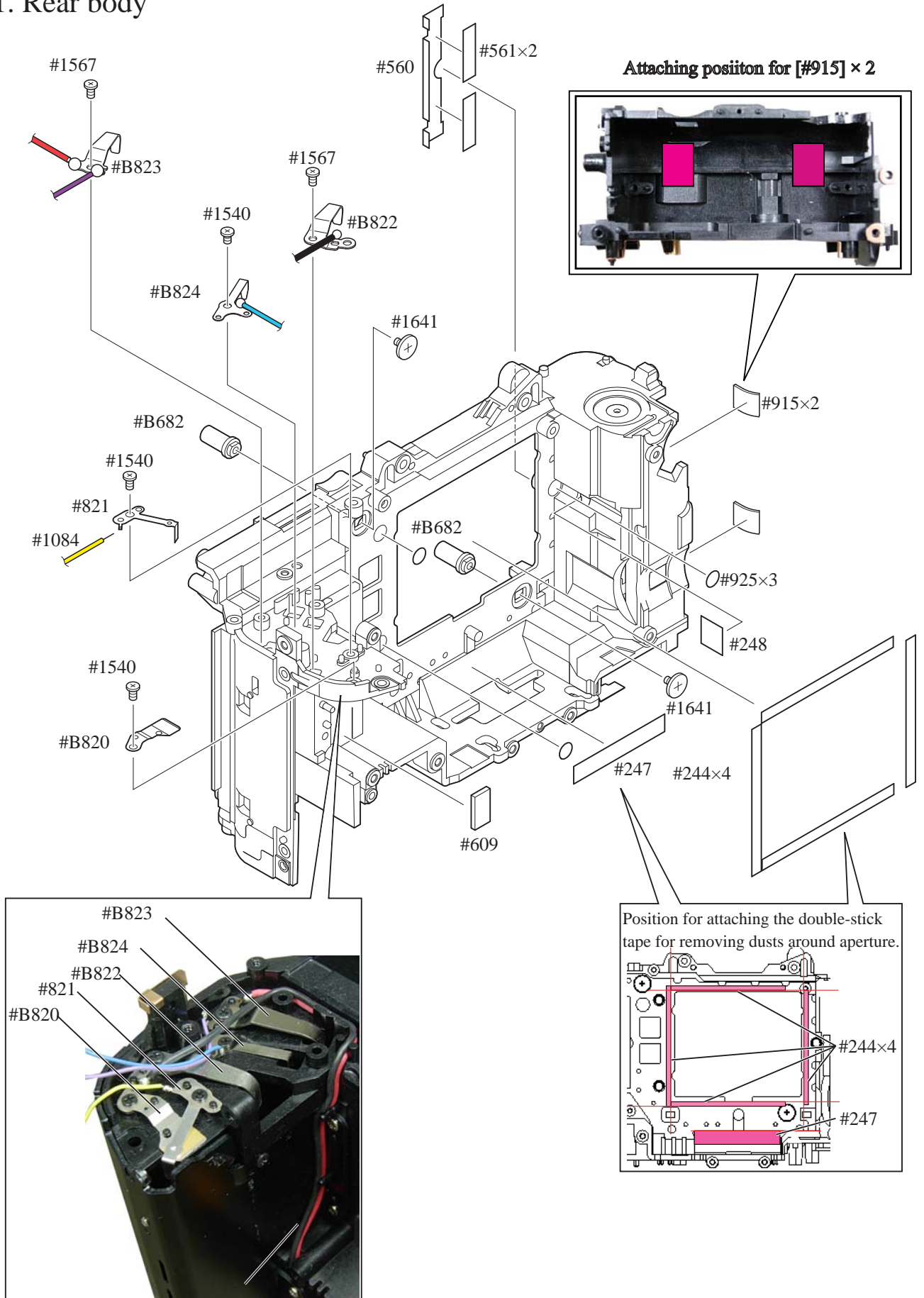

※ Arrange the wires (Red/Black) in the groove.

Shutter unit

- With the shutter unit (#31) charged (ready for releasing the shutter), assemble it into the body.
- Attach the conduction plate (#398).
- Tighten two screws (#1611) and one screw (#1541) (in numeric order from ① to ③.)
- Attach [#398] firmly with the tape (#956).

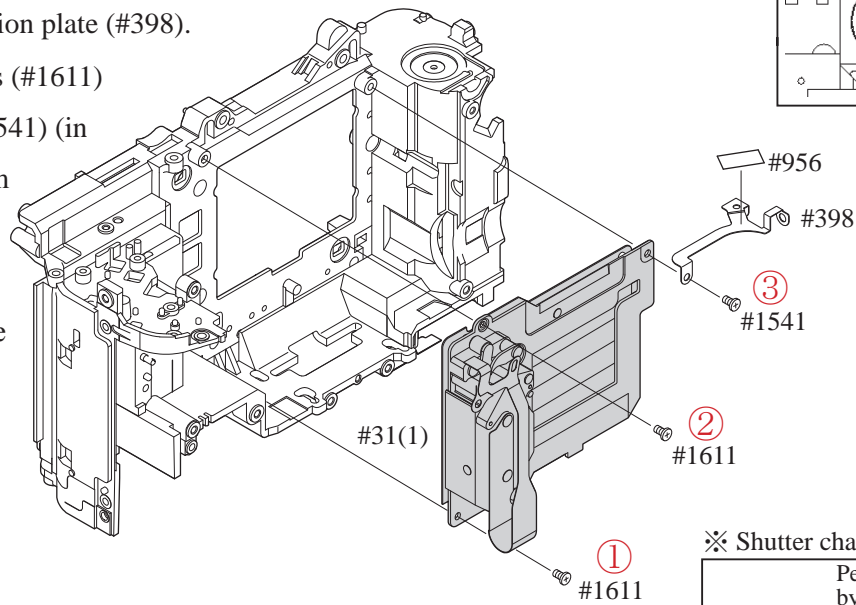

Position for attaching [#956]

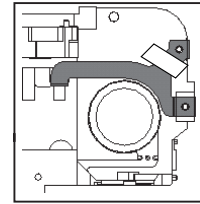

※ Shutter charge

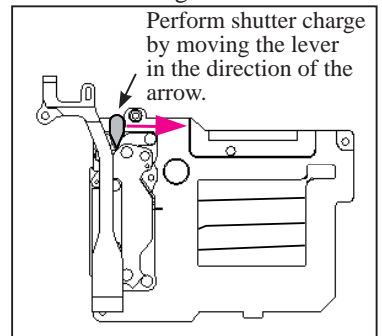

Charge base plate unit

- Confirm that the shutter unit (#31) is charged and the mirror-charge lever and shutter-charge lever are at the initial position.
- Mount the charge base plate unit (#B16620) on the body.
- While positioning [#B16620] by turning counterclock, tighten three screws (#1573) and one screw (#1572) in numeric order from ① to ④.

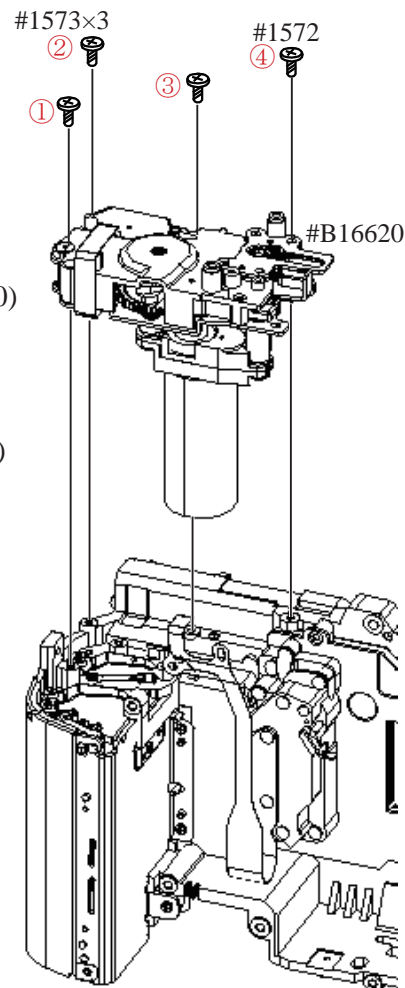

※ Initial position for charge lever

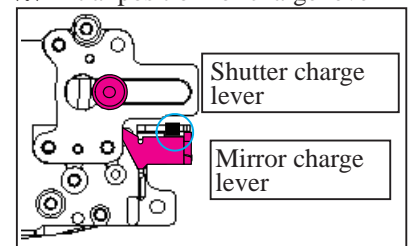

※ Direction for positioning [#B16620]

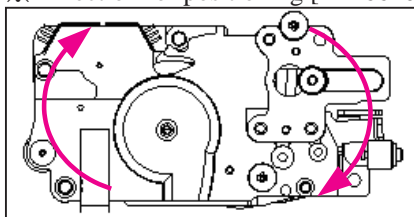

Charge base plate, I/F base plate, Main condenser and other small parts

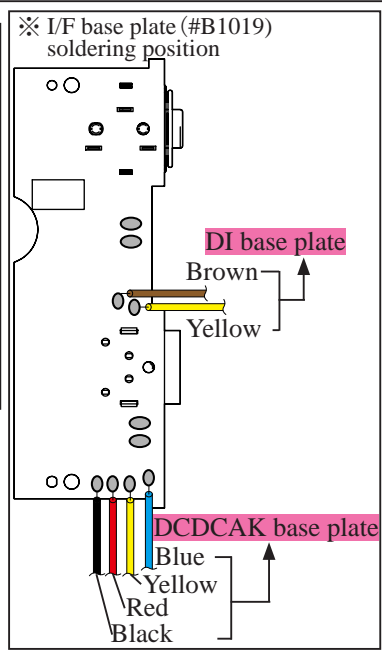
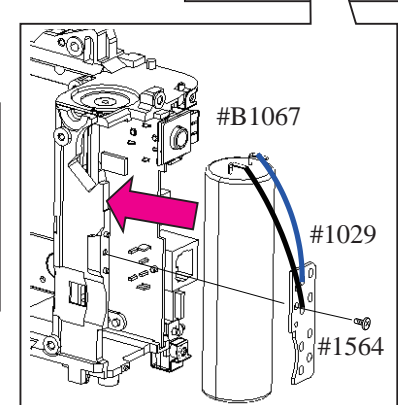
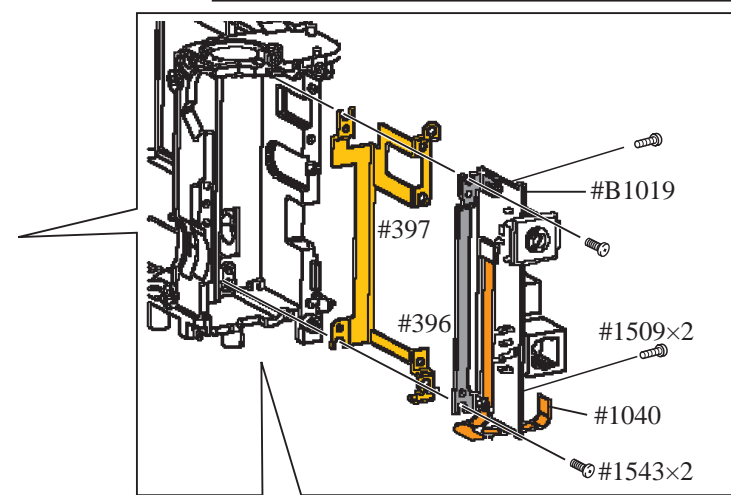
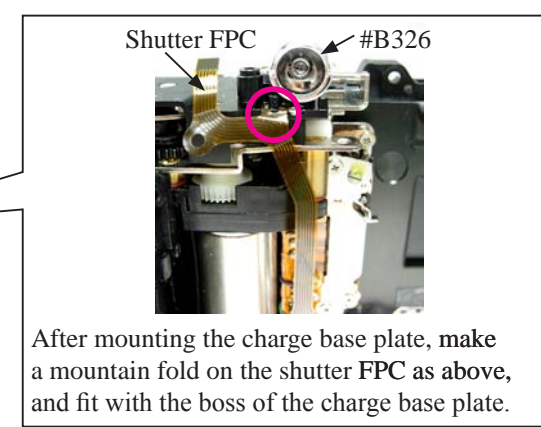
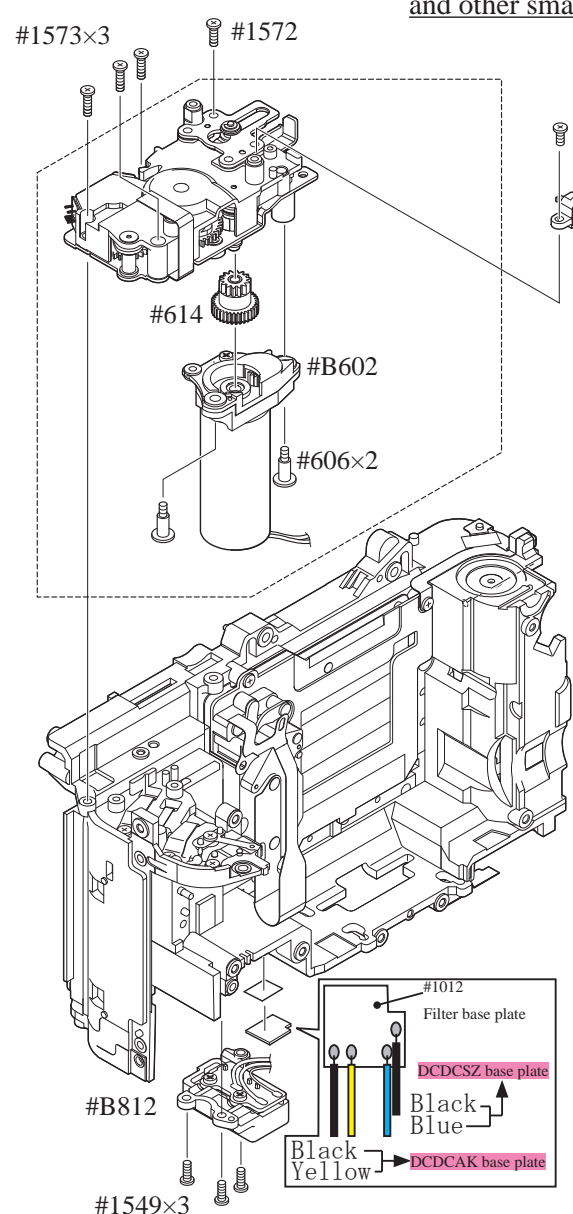

I/F base plate unit

- As shown in the illustration right above, mount the I/F base-plate fixing plate (#396) on the I/F base plate (#B1019). Then tighten the two screws (#1509).
- Connect the FPC (#1040) to the connector of the I/F base plate.
- Attach the GND plate (#397) by fitting it with the four bosses which are for positioning the body.
- Mount the I/F base plate (#B1019) by fitting in the body's groove and with two positioning bosses. Then, tighten the two screws (#1543).

DCDCAK base plate

- As below, while folding and fitting the FPC (#1040) in the body boss, mount the DCDCAK base plate (#1047) on the body.
- Tighten two screws (#1541) to fix [#1047].

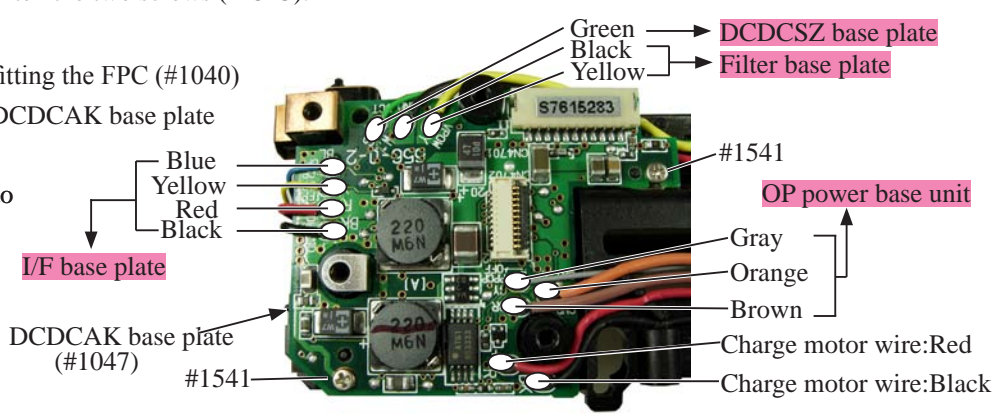
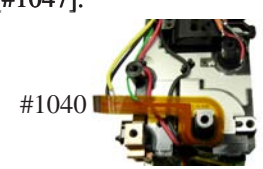

2. Front body

AF drive section, P/F button, Lens contact and other small parts

- As shown in the right middle illustration, position [#B1008] upwards and tighten the screw (#1615).
- Attach [#B1024] by fitting with the positioning boss of [#26].
- Make soldering bridges at three places to joint [#B1024] and [#B1008].

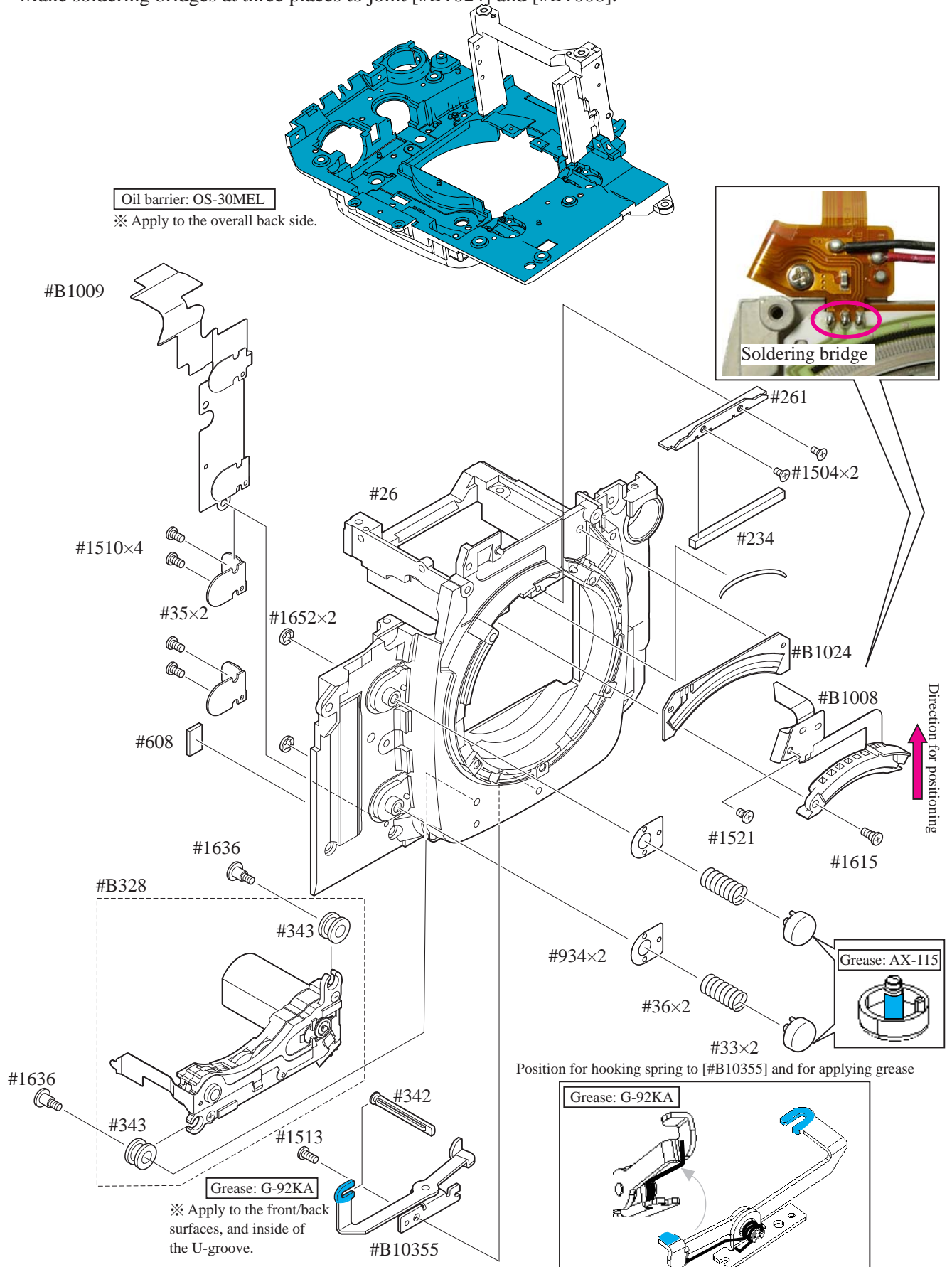

Mirror box, I base plate, Release base unit and other small parts

Mirror box unit

- Mount the mirror box unit (#B211) by fitting it with the boss and the front body.
- Position [#B211] in the direction of the arrow, and tighten three screws (#1525).

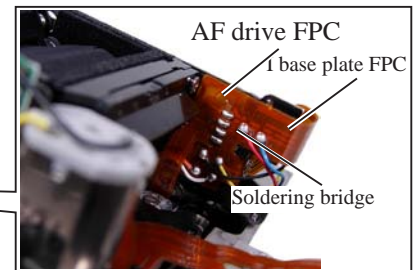
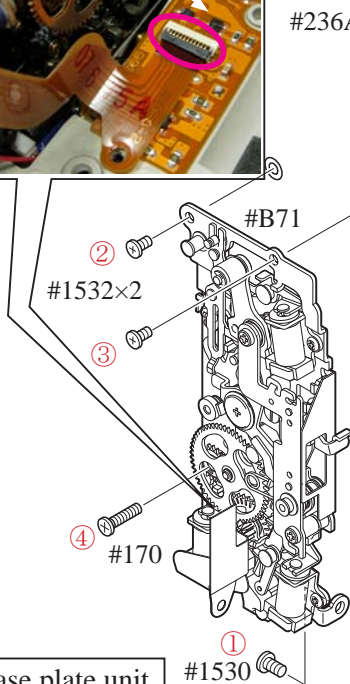
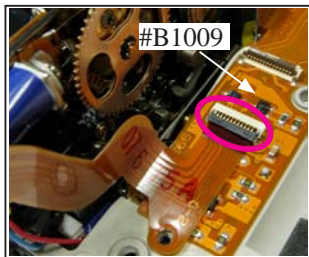
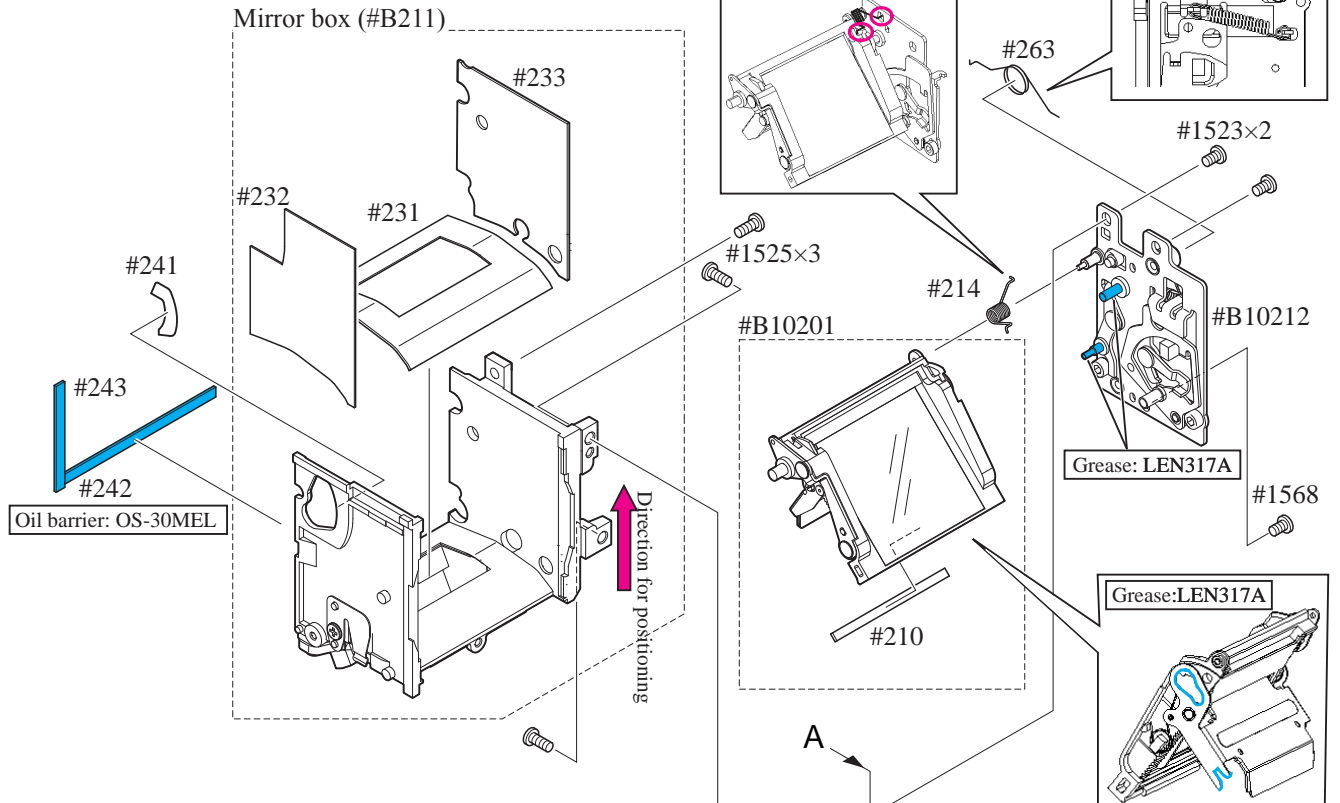

I base plate unit

- As above, mount the I base plate unit (#B71) by fitting it in the holes of [#B26] and with the bosses of [#B211].
- Tighten one screw (#1530), two screws (#1532) and one screw (#170) in numeric order from ① to ④.
- Connect the FPC to the connector of [#B1009].

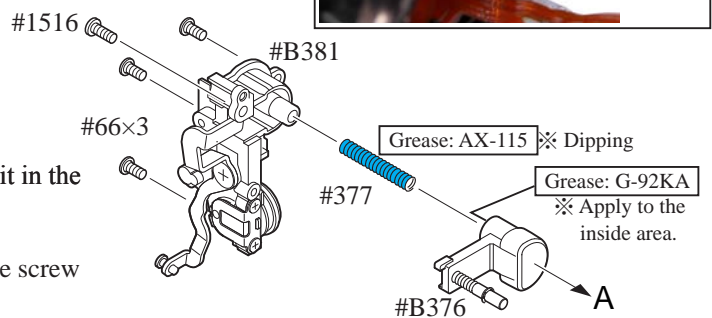

Front cover, Bayonet and other small parts

Oil barrier: OS-30MEL

※ Apply to the inside of each area so that the grease is not forced out.

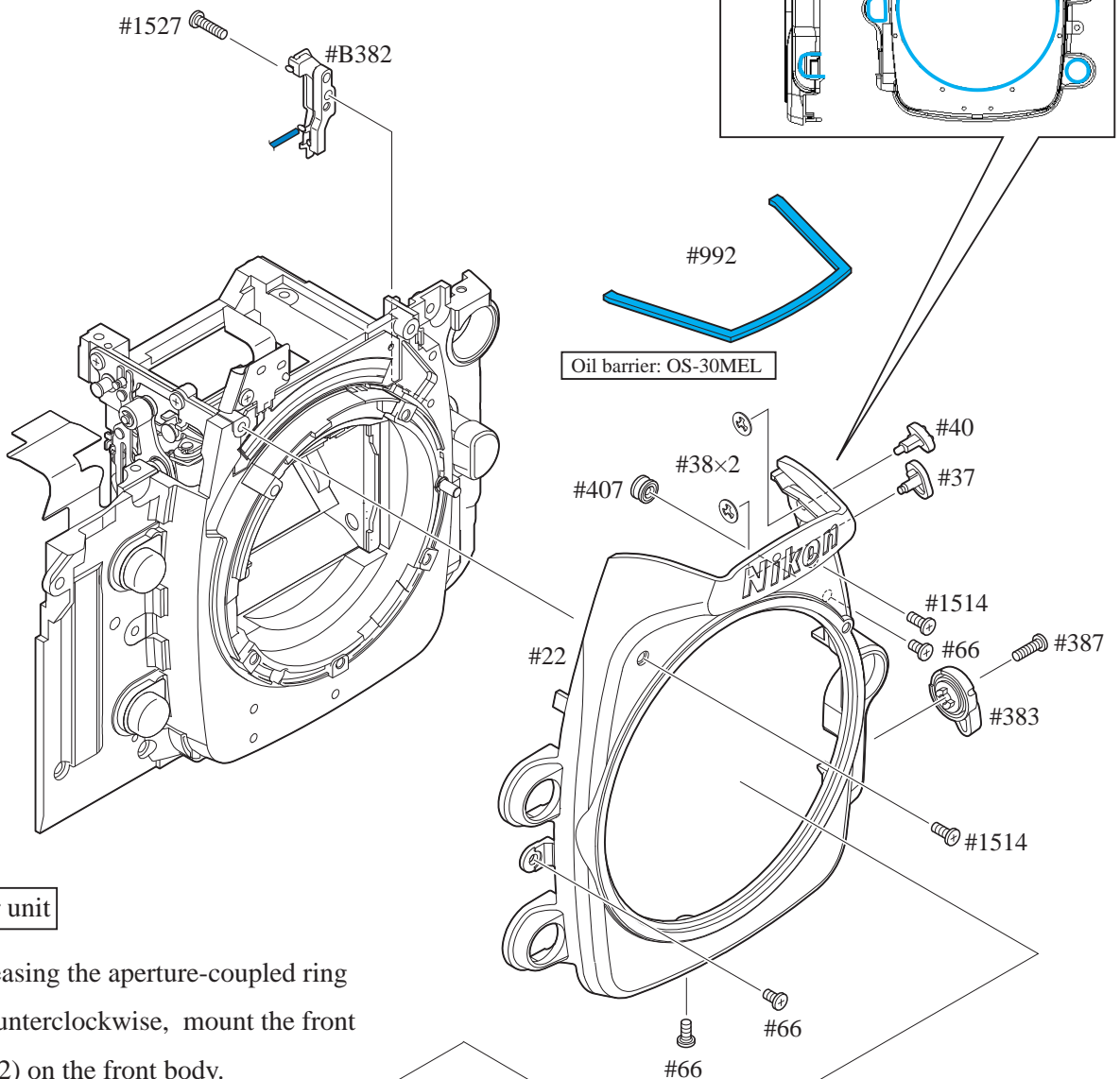
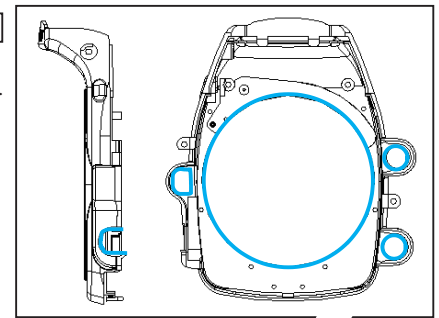

Front cover unit

- While releasing the aperture-coupled ring (#406) counterclockwise, mount the front cover (#22) on the front body.
- Tighten three screws (#66) and two screws (#1514).
- Attach the SCM-change lever(#383) and tighten the screw (#387).

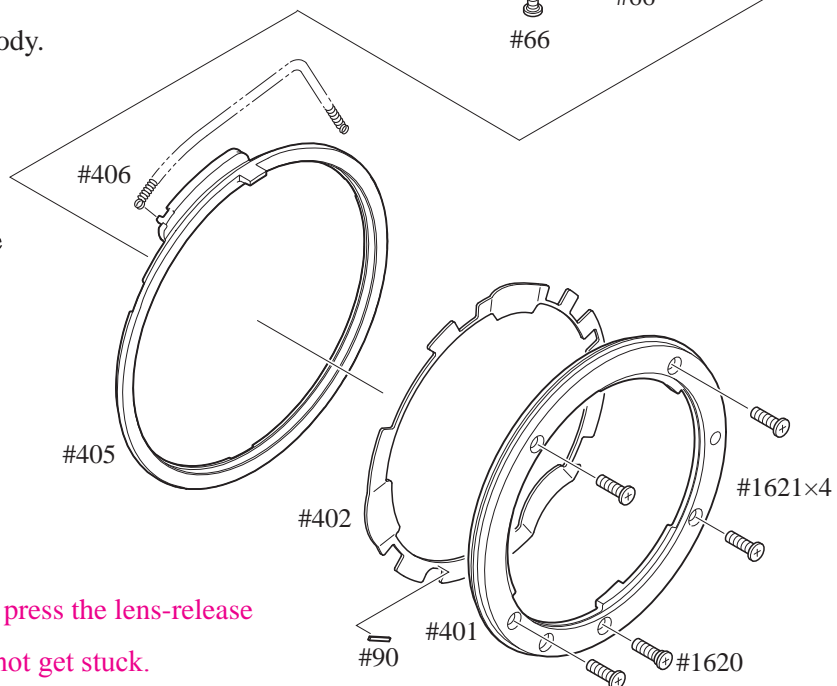

< Caution >

After mounting the bayonet, press the lens-release pin and confirm that it does not get stuck.

Height adjustment of AF coupling shaft

- Set the position of the focus mode select dial to "C".
- Adjust the height of the coupling shaft (#342) to become "1.7±0.2 mm" by using the screw (#359).
 - ※ When the focus mode is set to "S", [#342] does not move.
 - ※ When the focus mode is set to "M", [#342] must not protrude from the bayonet face.
 - ※ When the release-button is fully pressed, [#342] must not protrude from the bayonet face
- Fix the screw (#359) with the adhesive.

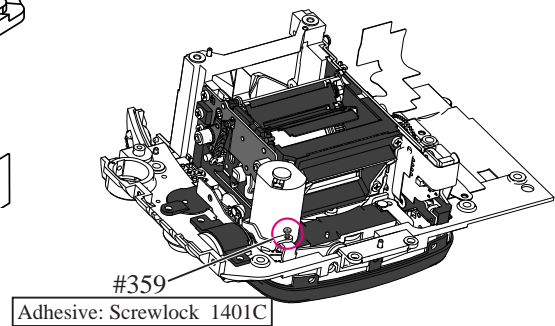
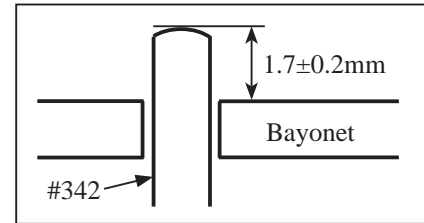
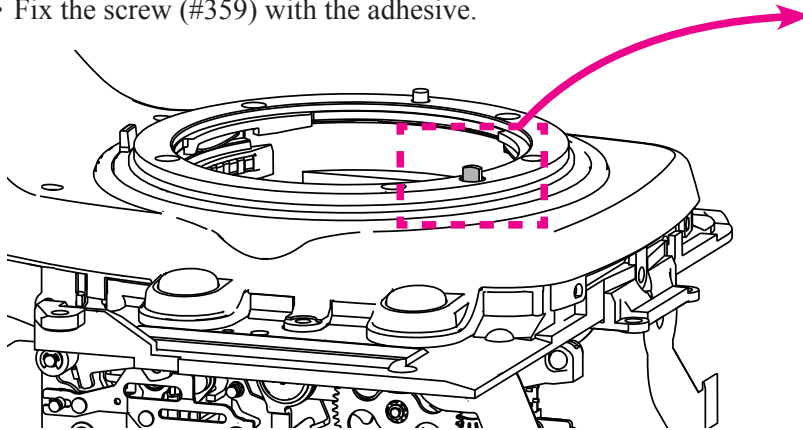

Height adjustment of Aperture lever

- Measure the height of the aperture lever by using the tool (J18004).
 - Standard: 3.4 - 3.45mm
 - Be careful NOT to bend the lever during adjustment.**
- If the result is out of standard, make the adjustment by using the adjustment screw.

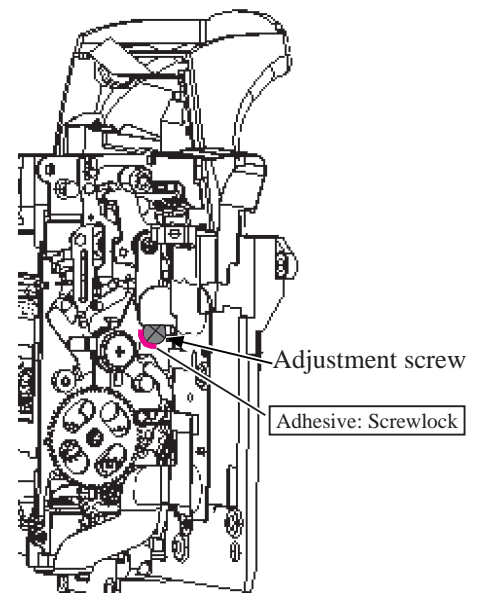
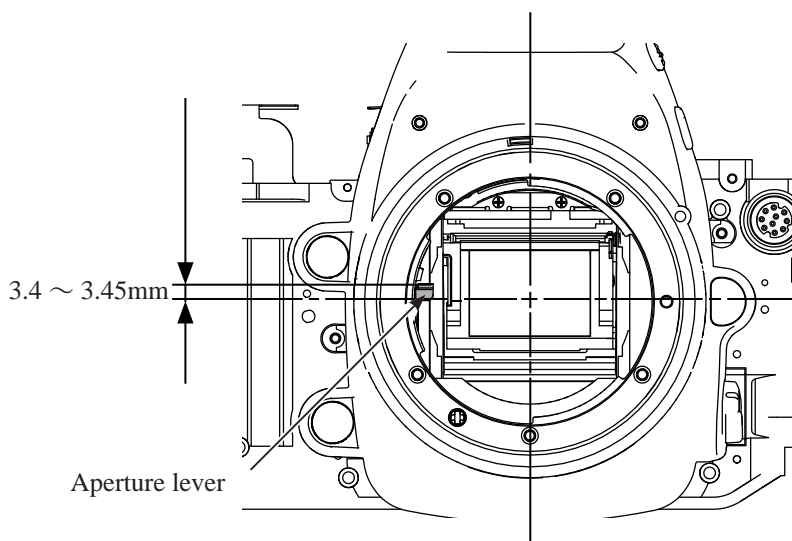

PD base plate/10 pin terminal

- Assemble the 10-pin terminal (#41) as below, and tighten the screw (#65).
- Attach the 10-pin FPC (#1010) by fitting with the bosses.
- Put the lens-release SW lug plate (#680) by fitting in the screw hole of [#1010], and tighten the screw (#1503).
- Make the solder to joint the 10-pin terminal and the FPC (at nine places), and solder the wire (#1119) of the lens-release SW on the lug plate (#680).
- Connect the FPC (#1042) to the connector of the PD base plate (#1002).
- Then mount the PD base plate (#1002) on the front body, and tighten two screws.
- Connect the 10-pin FPC (#1010) to the connector of [#1002].
- Solder the ten wires as below.

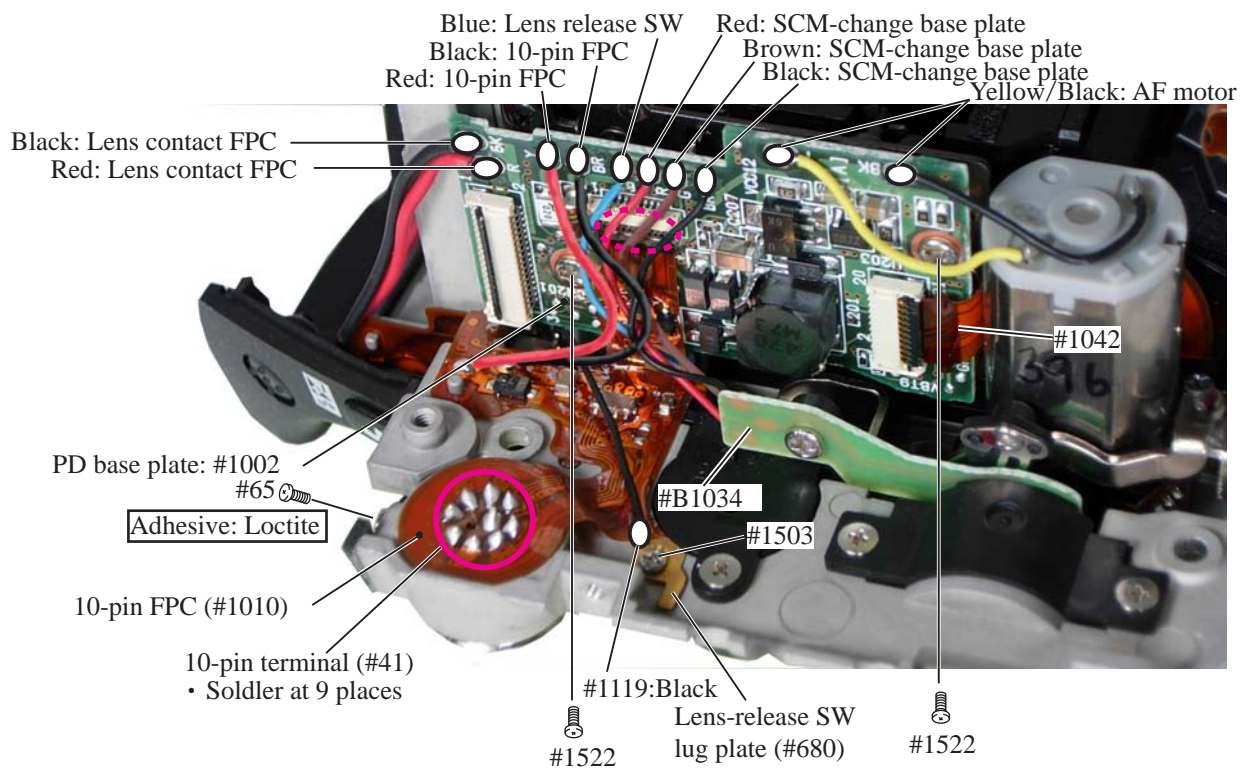

PD base plate, AF FPC unit and other small parts

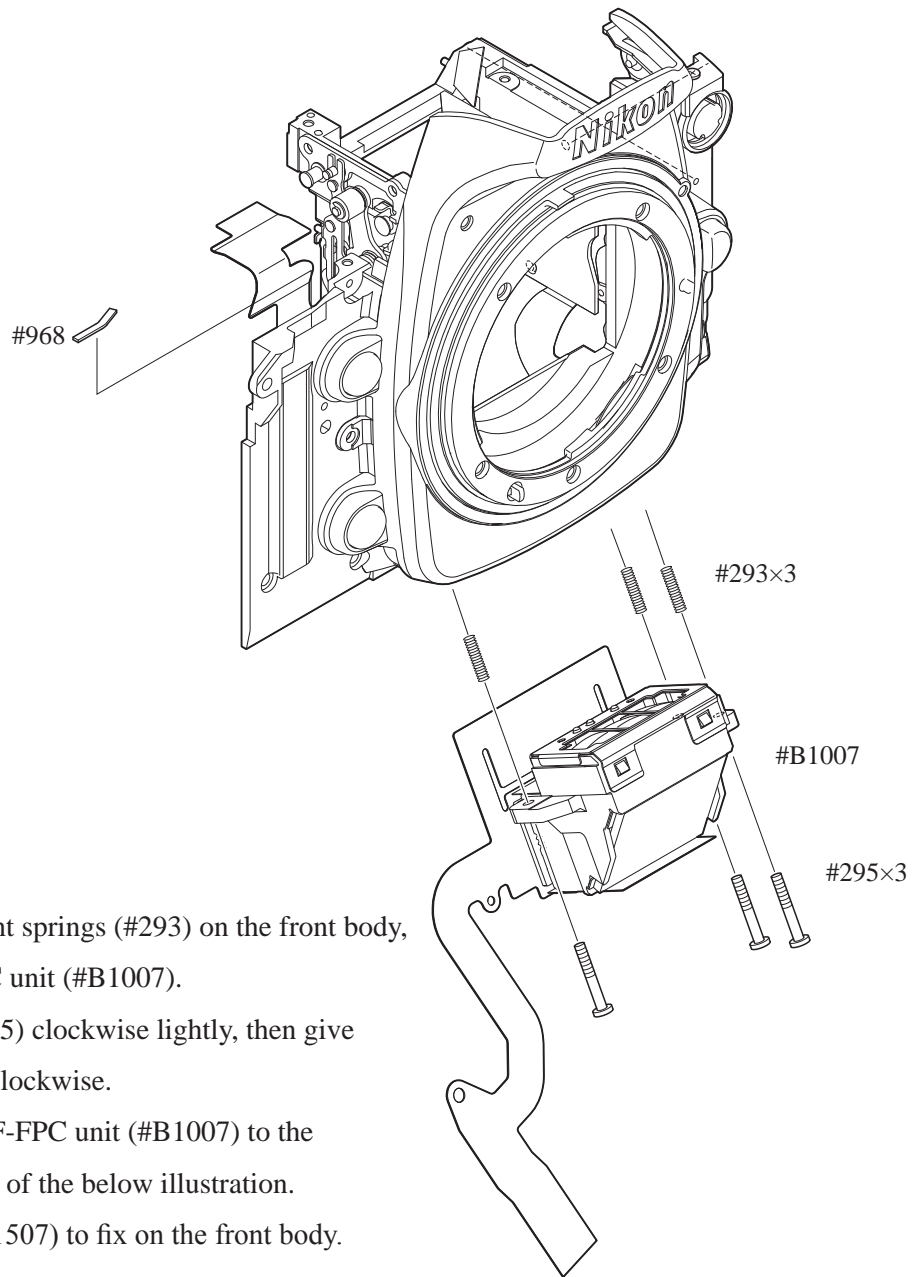

AF FPC unit

- Put the three adjustment springs (#293) on the front body, and mount the AF-FPC unit (#B1007).
- Turn three screws (#295) clockwise lightly, then give them one turn counterclockwise.
- Connect the FPC of AF-FPC unit (#B1007) to the connector of [#B1009] of the below illustration.
- Tighten two screws (#1507) to fix on the front body.

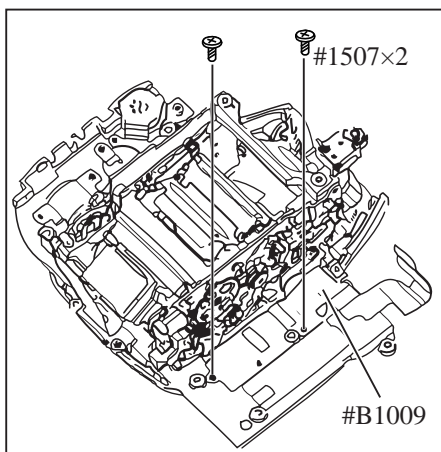

P. Box unit

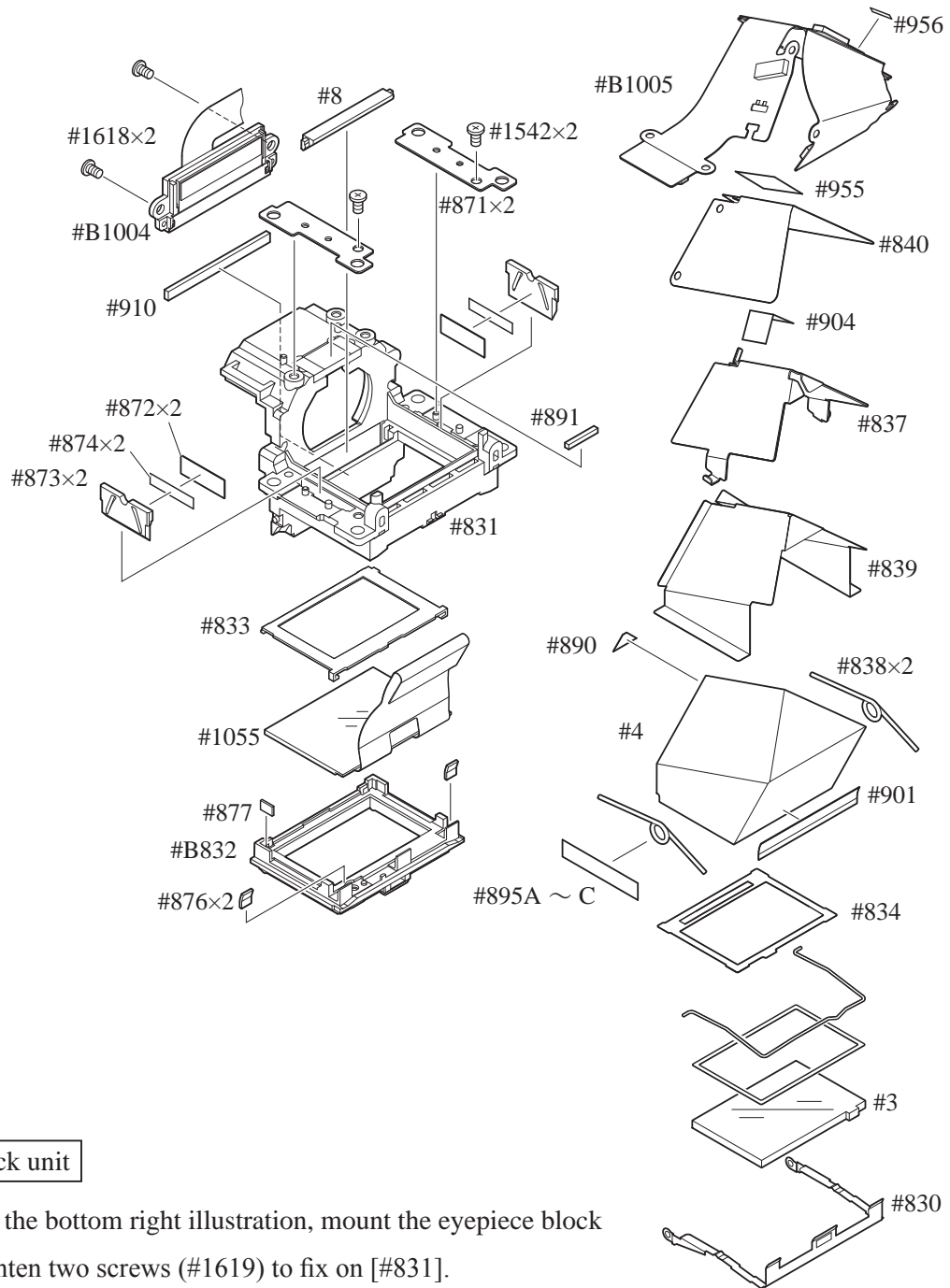

Eyepiece block unit

- As shown in the bottom right illustration, mount the eyepiece block unit, and tighten two screws (#1619) to fix on [#831].
- Attach the dustproof tape (#909).

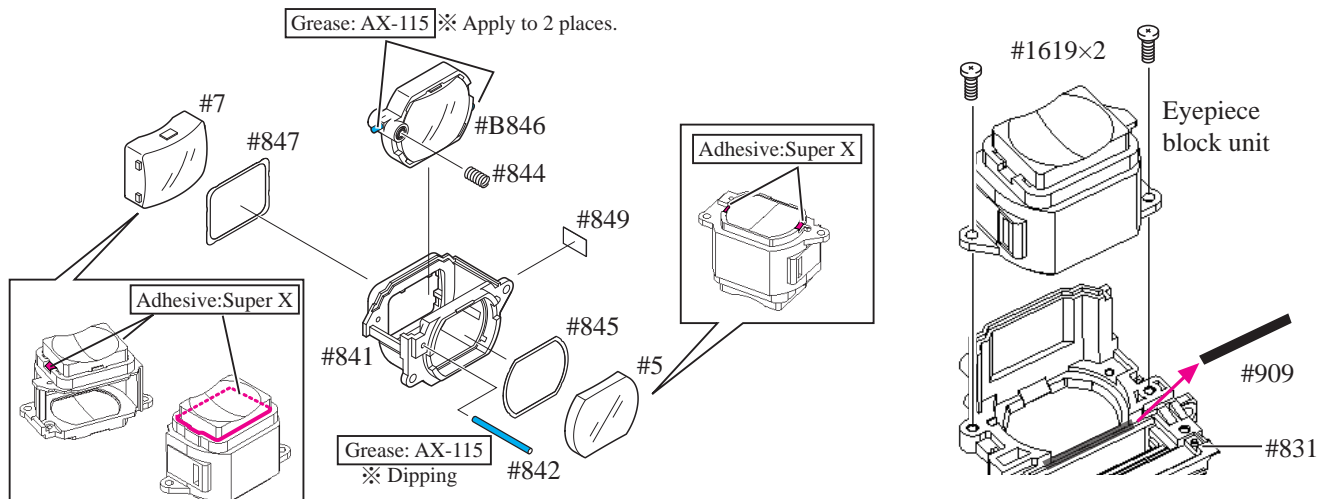

AE FPC unit

1. Assembly

- Put three AE adjustment springs (#884) on [#B882].

- Mount the AE block (#B1006) on [#B882].
※ Mount by fitting the AE adjustment springs with concave portions of the AE block.

※ Be careful that the springs (#884) do not run off the edge from the areas that joint with [#B1006].

- Turn three screws (#883) to attach [#B1006] to [#B882] temporarily.

※ Give the screws light turns.

- Then, give the three screws (#883) one and half turn counterclockwise.

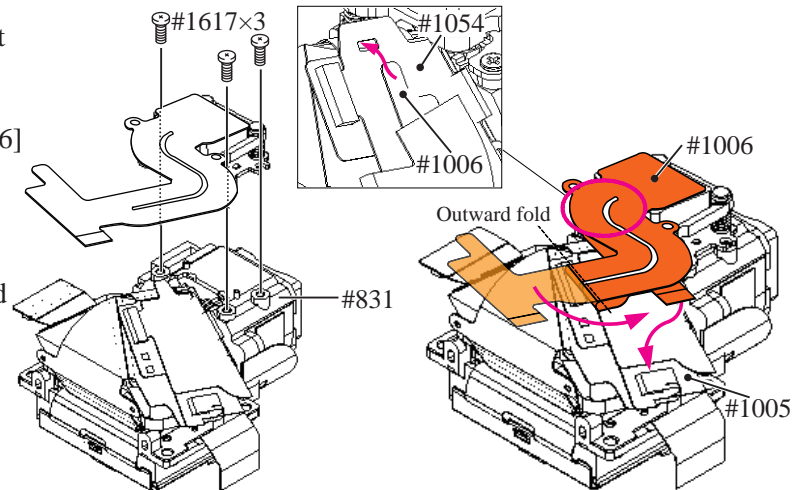
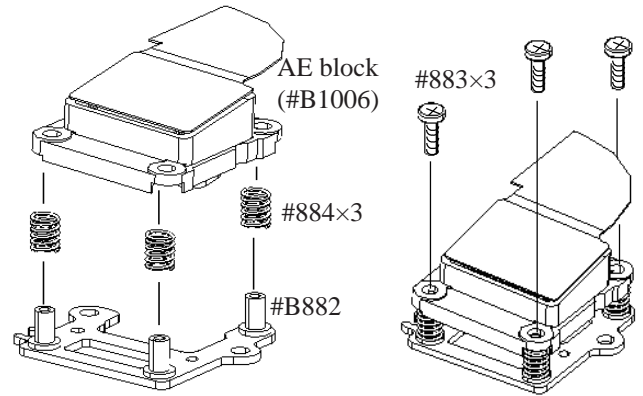

2. Installment

- Mount the AE FPC unit on [#831].
- Tighten three screws (#1617).
- Fold the FPC (#1006) and connect to the connector of the FPC (#1005).
- Hook the top edge of the FPC (#1006) to the hole of [#1054].

Installment of P. Box unit

- Assemble the P. Box unit into the body, and tighten four screws (#1612).
- Connect the penta-FPC (#1005) to the connector of PD base plate (#1002).
- Connect the lens contact FPC unit (#B1008) to the connector of the penta-FPC (#1005).

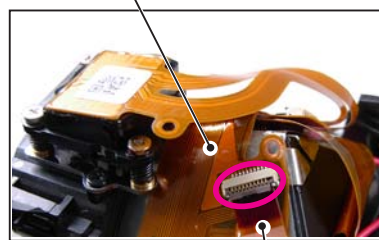
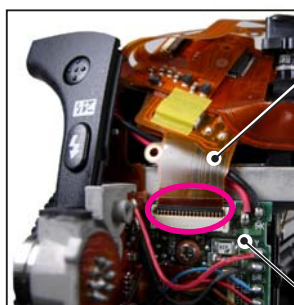

Lens-contact FPC unit (#1008)
PD base plate #1002

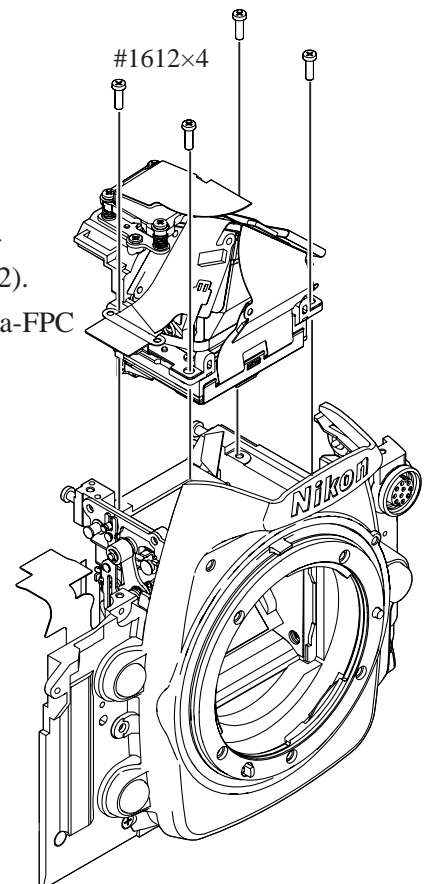

Angle adjustment of Main mirror and sub-mirror

※ Procedure: Follow the operating instructions of the tool for main/sub mirror angle-inspection (J19132).

• Main mirror 45° adjustment

Caution: Before and after the adjustment, check the accuracy by moving the main mirror up- and downwards a few times.

① Check for the right-left deviation

In case the result is out of standard, loose the two screws (#1523) and one screw (#1568), then make the adjustment by moving the main mirror shaft PCB (#B10212).

② Check for the up-down deviation.

In case the result is out of standard, make the adjustment by turning the eccentric pin.

• Sub-mirror 59° adjustment

Caution: Before and after the adjustment, check the accuracy by moving the main mirror up- and downwards a few times. Confirm if the two-pronged part of the sub-mirror firmly fits in the eccentric pin.

① Check for the up-down deviation

In case the result is out of standard, make the adjustment by turning the sub-mirror eccentric pin.

< Device >

1. For Main mirror adjustment

- ① Mirror angle inspection tool
- ② 45° angle mirror tool
- ③ Hexagonal wrench (φ1.5mm)

2. For sub-mirror adjustment

- ① Mirror angle inspection tool
- ② Hexagonal wrench (φ1.5mm)

① Mirror angle-inspection tool

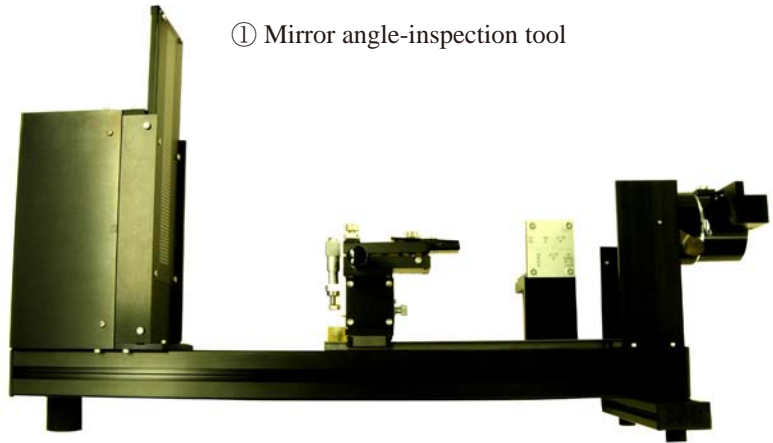

Caution : Do NOT release the shutter.

Set the (supplied) tilted mirror with the main mirror being slightly lifted so that the sub-mirror of D300 does not touch the (supplied) tilted mirror of the inspection tool.

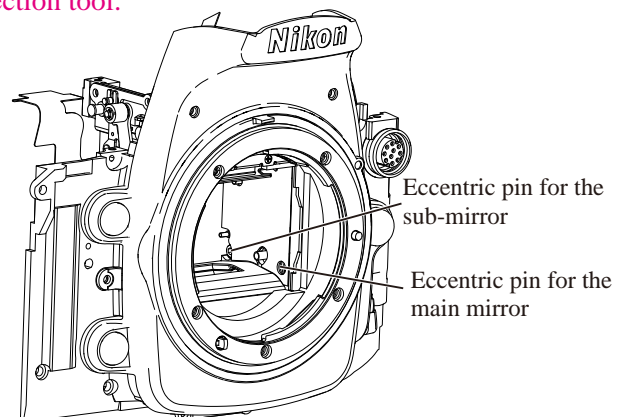
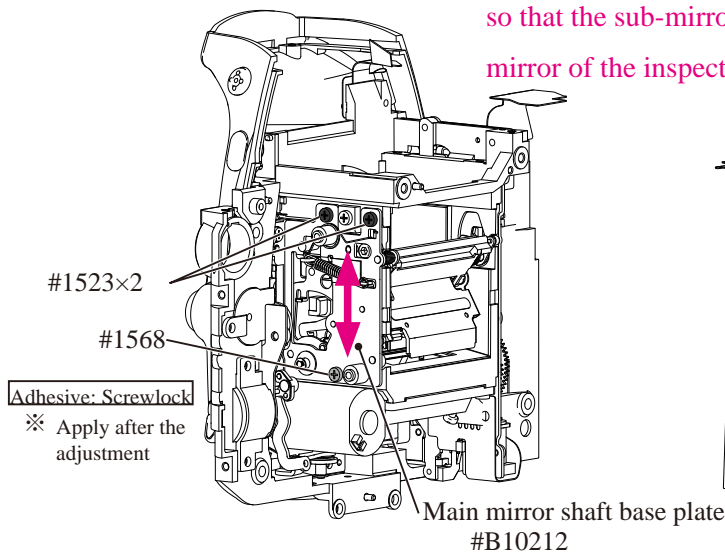

< Standard value >

	Main mirror	Sub-mirror
Left-right deviation	±10'	-
Up-down deviation	±5'	±10' -15±15' △
Distortion	6' or less	6' or less

(Revision)
サービス
計画課
M

3. Mounting of Front body on Rear body

Mounting of Front body on Rear body

- Assemble the front body into the rear body. Then, viewed from the front body, tighten one screw (#1572) and four screws (#1575) in numeric number from ① to ⑤ .
- Tighten two screws (#1531), one screw (#1525), and two screws (#1575).
- Connect the FPC (#1042) to the connector of [#1047].

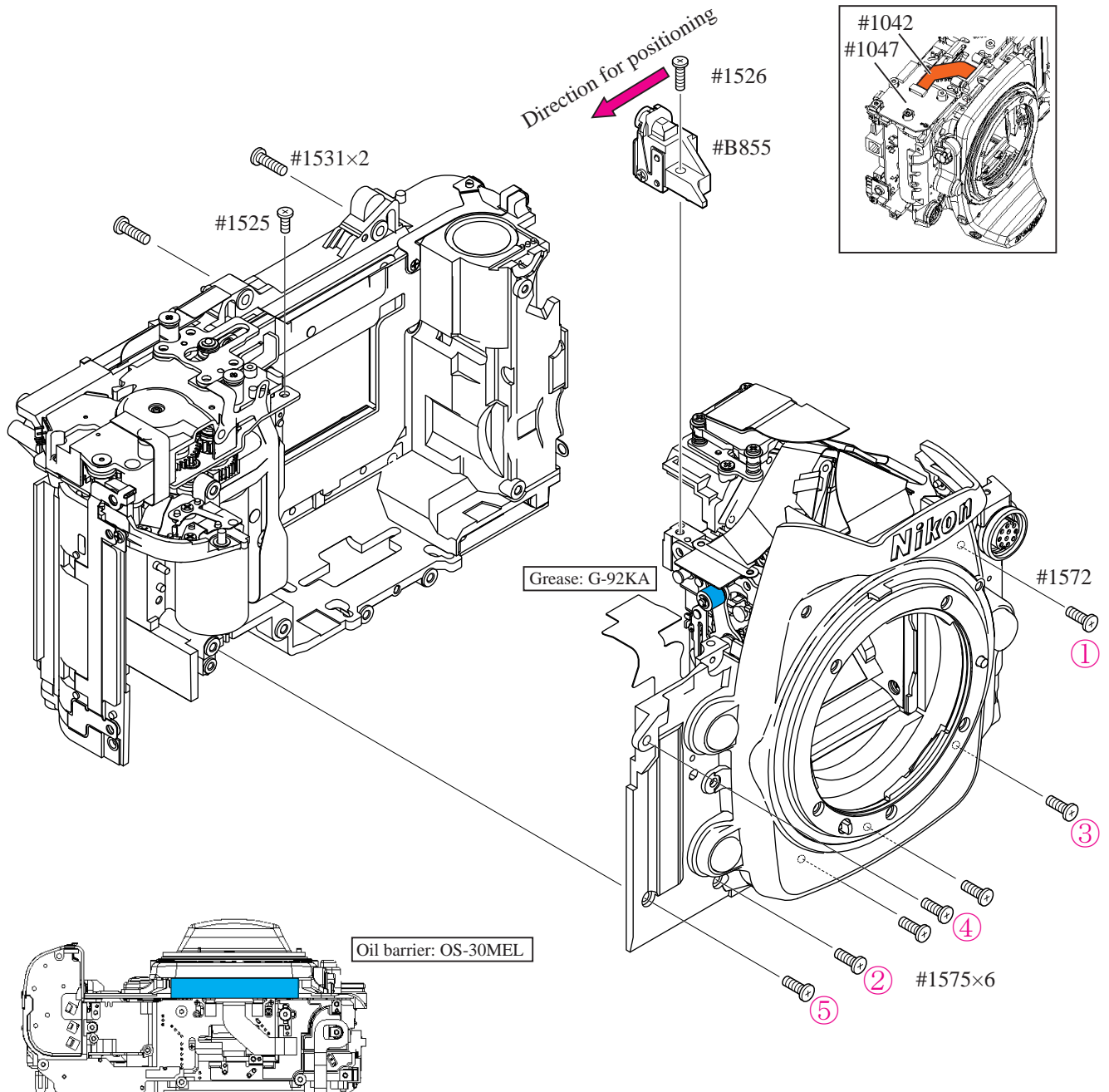

Inspection and Adjustment of Body back

- "0" positioning of the dial gauge

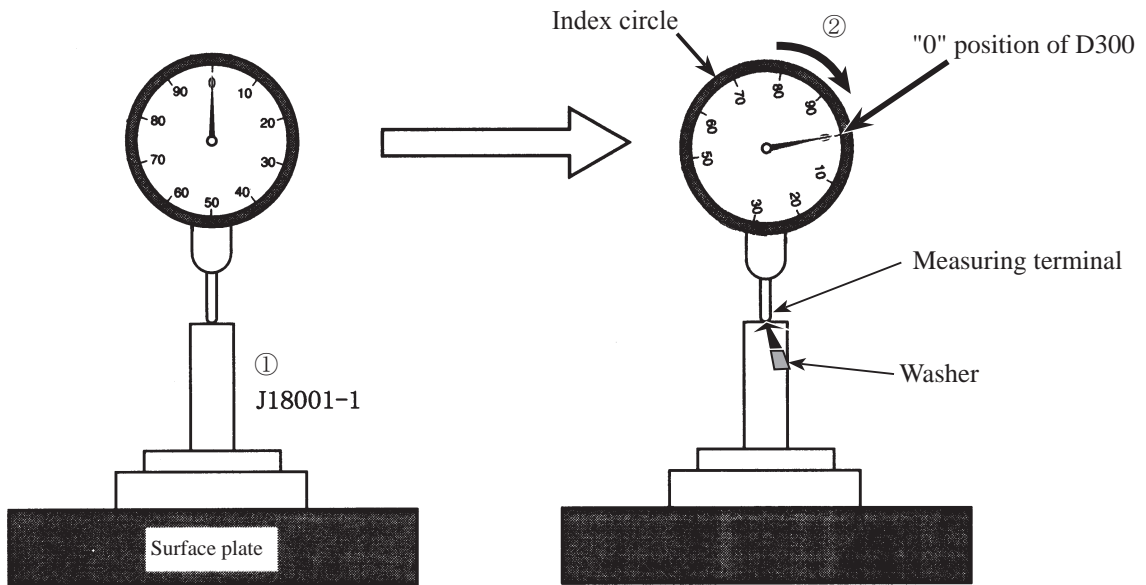

- ① Put the tool (J18001-1) on the surface plate.
- ② Put the washers corresponding to 1.82 mm-width [e.g. Three washers (1.0mm, 0.8mm, and 0.02mm)] between the tool (J18001-1) and the measuring terminal of the gauge, and turn the index circle to set to "0". (Reset the digital gauge to "0".) (This is "0"-position of D300.)

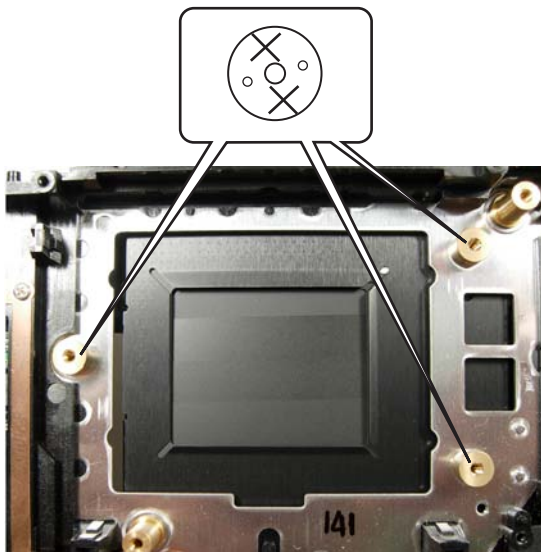

- Measure six places from the bayonet face to the image PCB attaching face.
× mark: to be measured
Standard: 48.49±0.01mm / Parallelism: 0.015mm or less
- In case the result is out of standard, make an adjustment by putting the washers between the front body and the rear body.

Note: For some bodies, the washer(s) is/are already put on the attaching face of the image PCB . There is a red mark indication at the following two positions.

1. Indication: on the attaching face of the camera body side
Purpose : To adjust the height of the camera body
2. Indication: on the attaching face of the image PCB side
Purpose : To adjust the height of the image PCB

Therefore, in case of the above 1., when the camera body is disassembled or the image PCB is replaced, put the washer at the original position. In case of the above 2., when the image PCB is replaced, remove the washer.

Main PCB unit

- As below, mount [#775] on the body.
- Referring to the right picture, connect the FPC (#B1005) to the connector of the main PCB (#B1001).
- Mount [#B1001] on the body.
- Tighten three screws (#1616).
- Connect the FPCs (#1009 and #1030) and shutter-FPC to each connector of [#B1001].

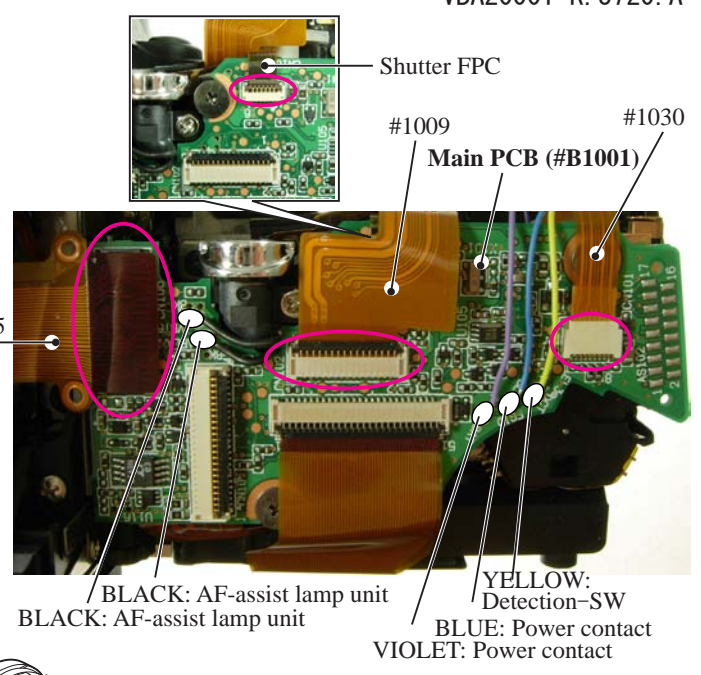

Eyepiece mold unit

- Mount the eyepiece mold unit (#B861) by fitting with the two positioning bosses.
- Tighten two screws (#1619).

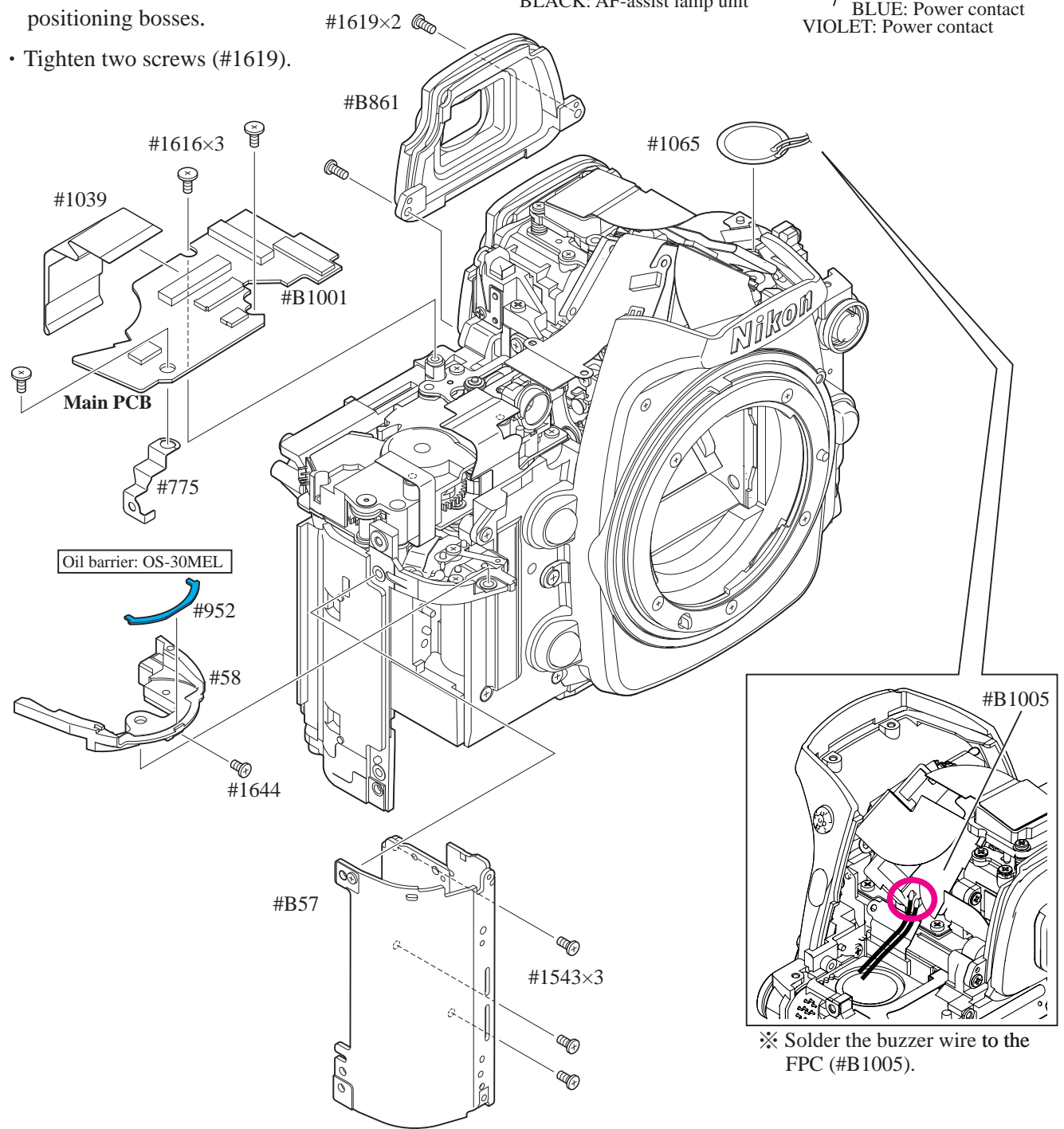

Eyelet, AF-assist illuminator protector, Function-button external ring < Adhesive >

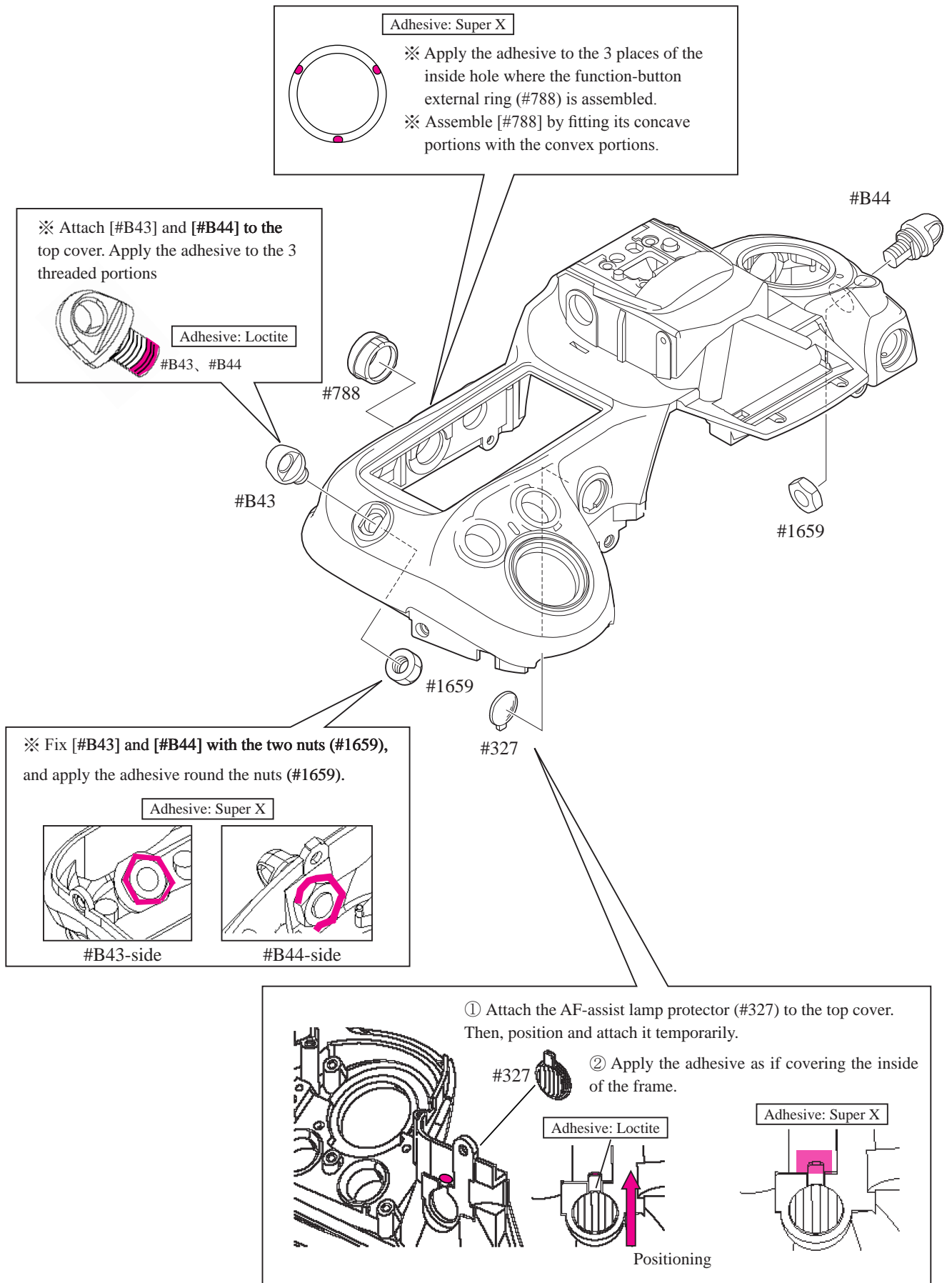

Mode dial, Trefoil rubber button and other small parts

Mode dial FPC unit

- Attach the playback/DEL button (#513) to the top cover.
- Apply the contact grease to the pattern area of [#1025].
- Mount the mode dial FPC unit on the top cover, and tighten two screws (#1609) and one screw (#1571).

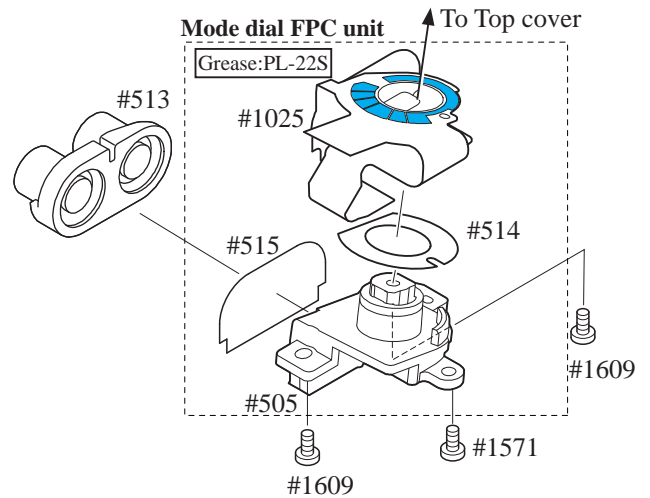

Mode dial / Trefoil button

- As below, apply the grease to the mode dial unit, and mount it on the top cover.
- Mount the trefoil rubber button unit on the mode dial unit (while passing through the hole of #1026), and tighten the screw (#1574).

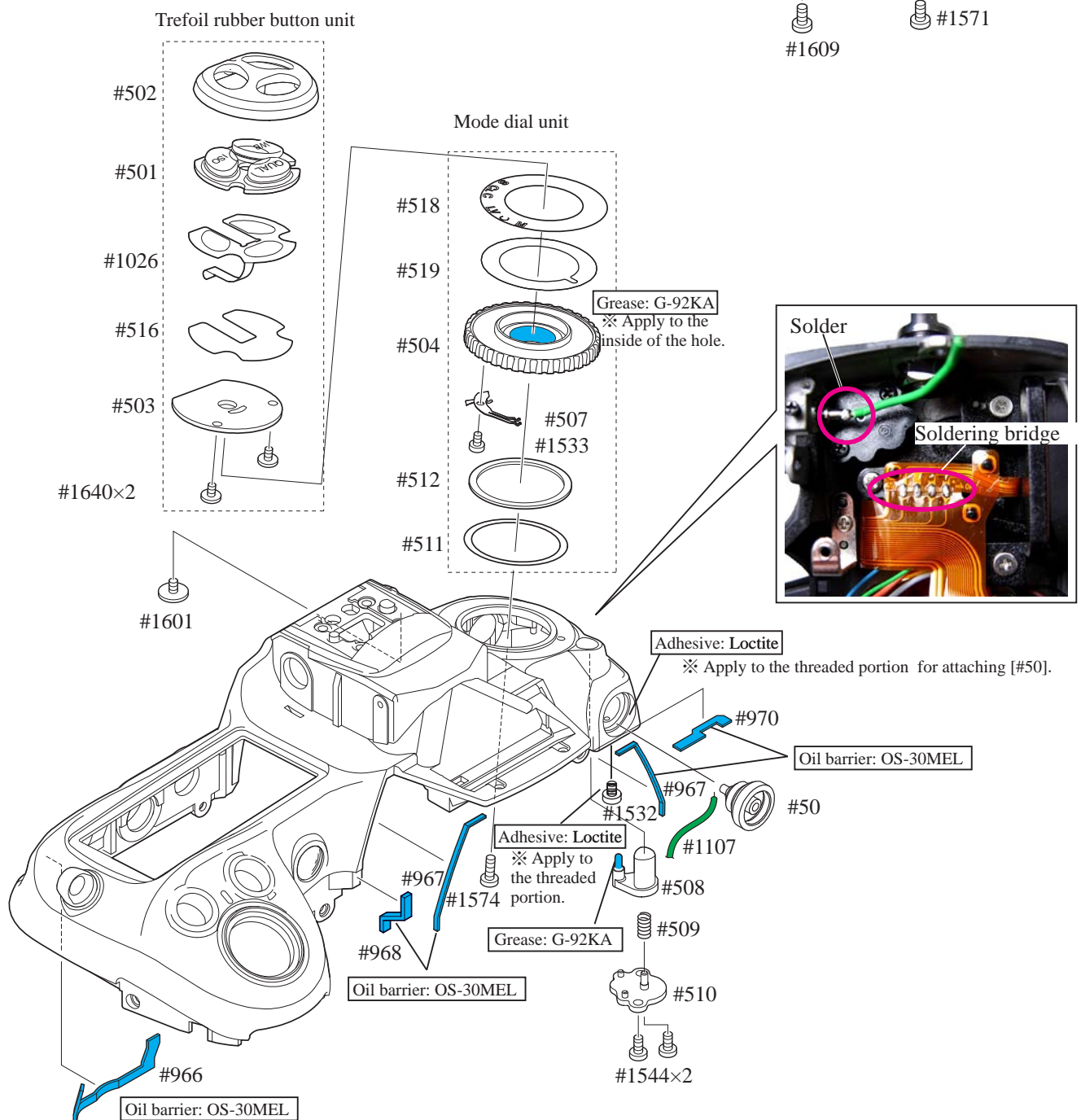

SB case, Synchrono-terminal and other small parts

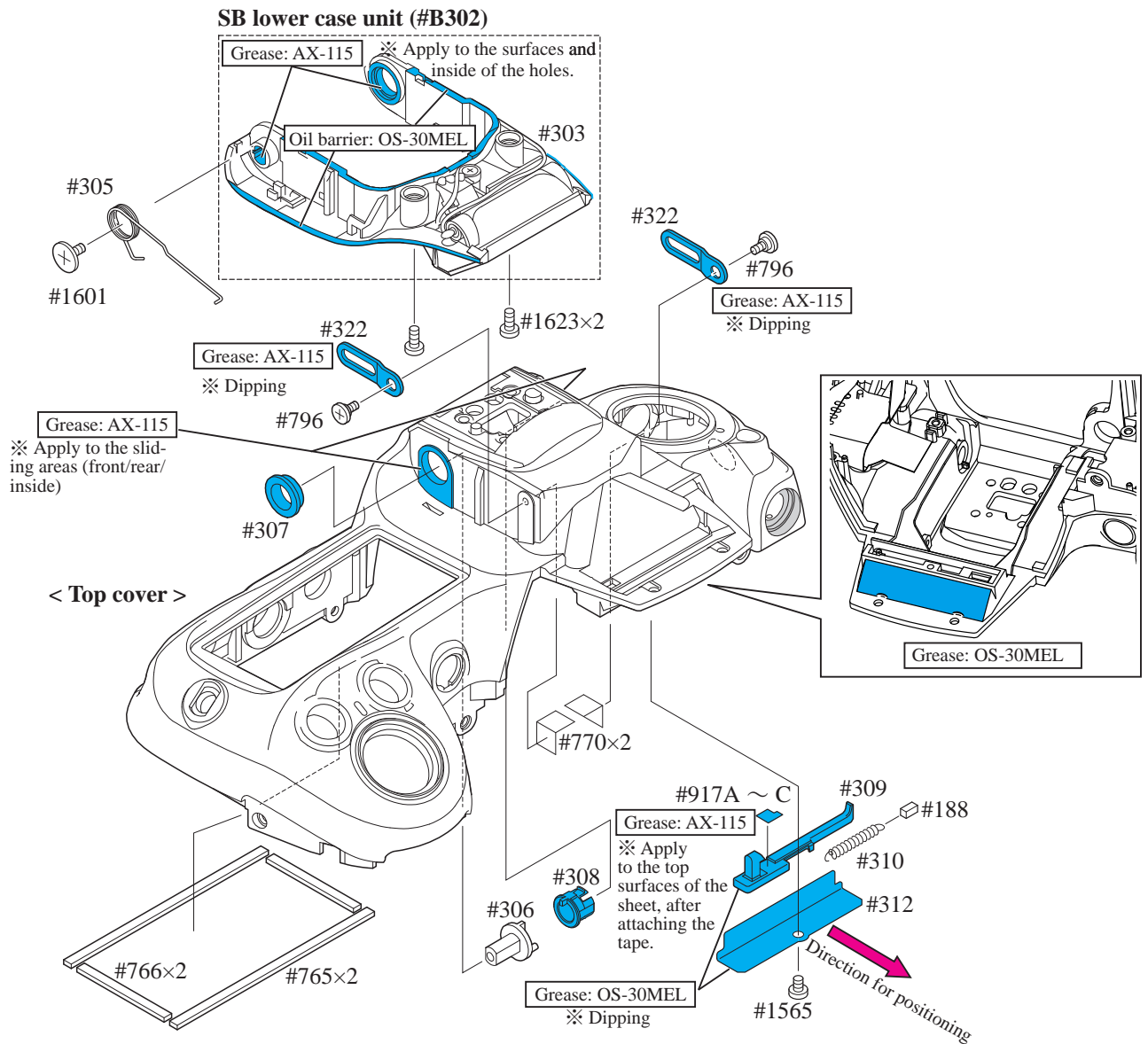

- Attach two of [#322] to the top cover, and tighten two screws (#796).
- Attach [#307] to the top cover.
- Mount the SB lower case unit (#B302) on the top cover.
 - ※ Mount [#B302] by fitting its boss section in the grooved section of [#322].

- Attach [#308] to the top cover.
- Attach [#306] to the top cover.
- ※ Attach by aligning [#306] with the small holes of the SB lower case unit (#B302).

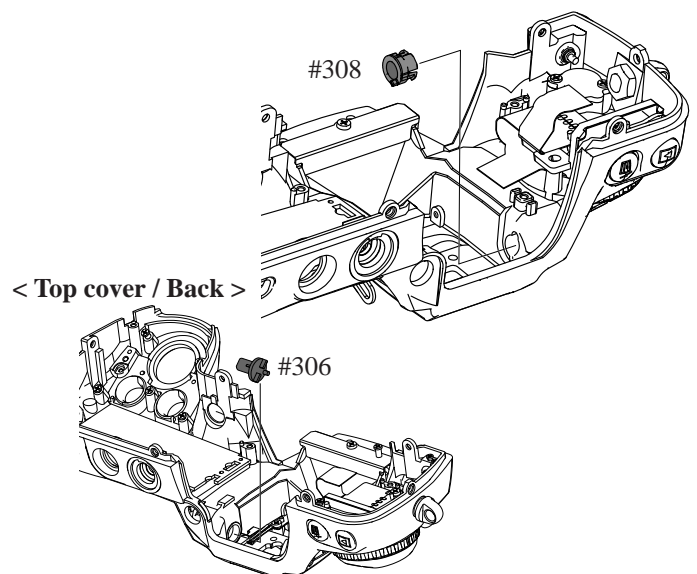

- Put the SB-up spring (#305) on [#B302], and tighten the screw (#1601) to fix on [#306].
- Attach [#305] to the hooking part of [#B302].

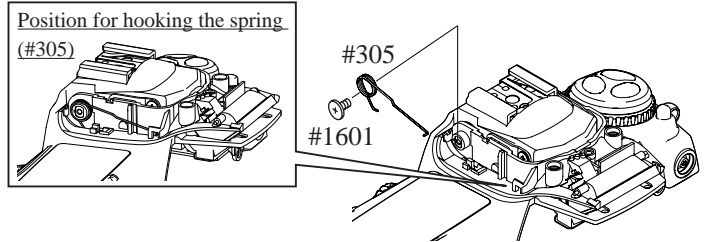

- Apply the grease to the contacting area between [#308] and SB wire.
- Arrange the wires of the SB lower case unit (#B302) on the top cover. (Thick wire comes to the inside.)

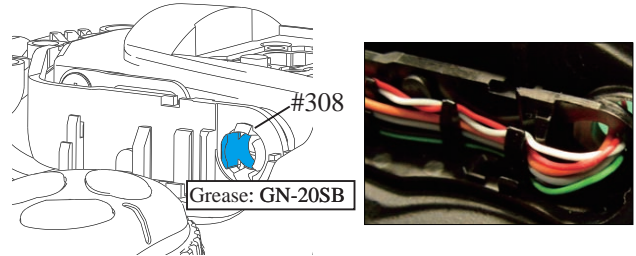

- Mount the SB upper case (#301) on [#B302].
- ※ Mount by hooking the two craws of [#301] firmly.

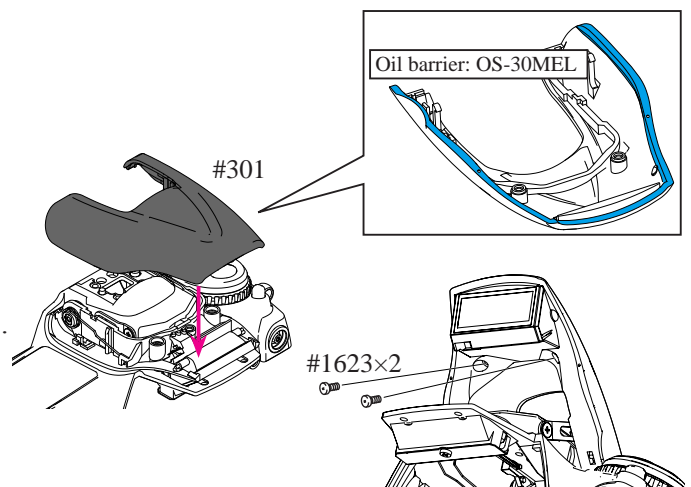

- Operate [#309] to unlock. (ref. Previous page)
- Tighten two screws (#1623) to fix [#301] on [#B302].

Metering mode dial, Release button and other small parts

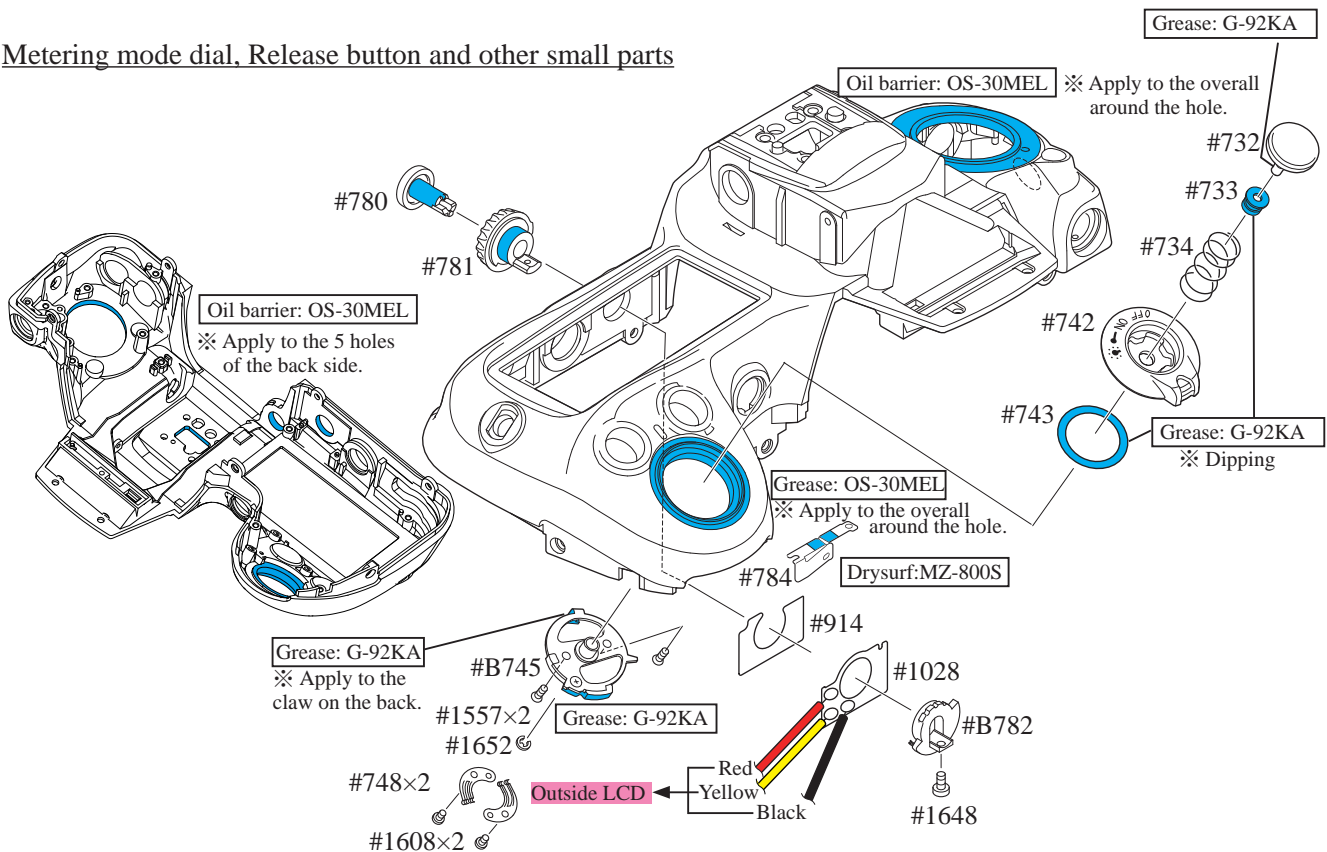

Outside LCD/FPC unit

- Attach the compensation/mode button rubber SW (#730) and AF-ON button rubber (#787).
- Apply the grease to the power dial pattern section.
- Connect the mode dial FPC to the connector.

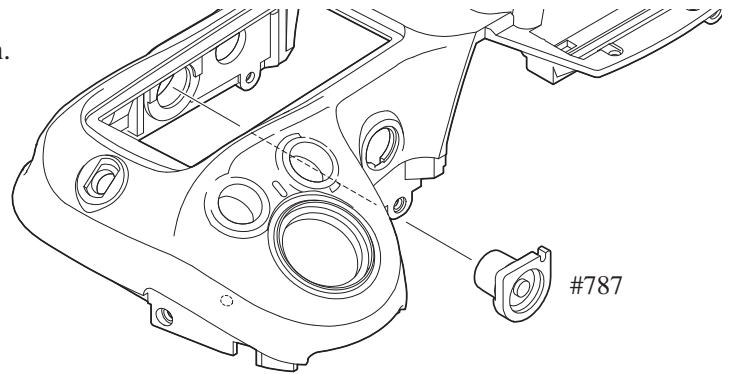
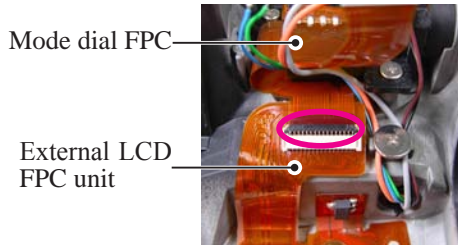

- Mount the outside LCD FPC unit to the top cover.
- Tighten two screws (#1547), three screws (#1544), two screws (#1540), and one screw (#1560).
- Solder the three wires.

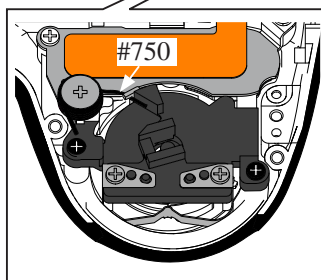
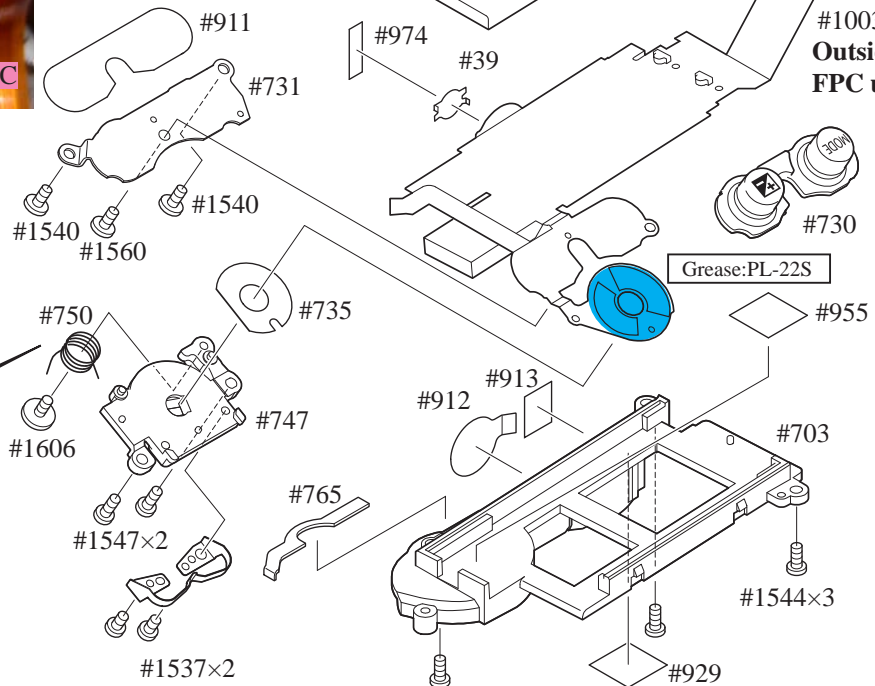
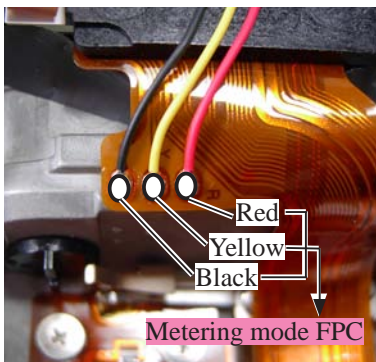
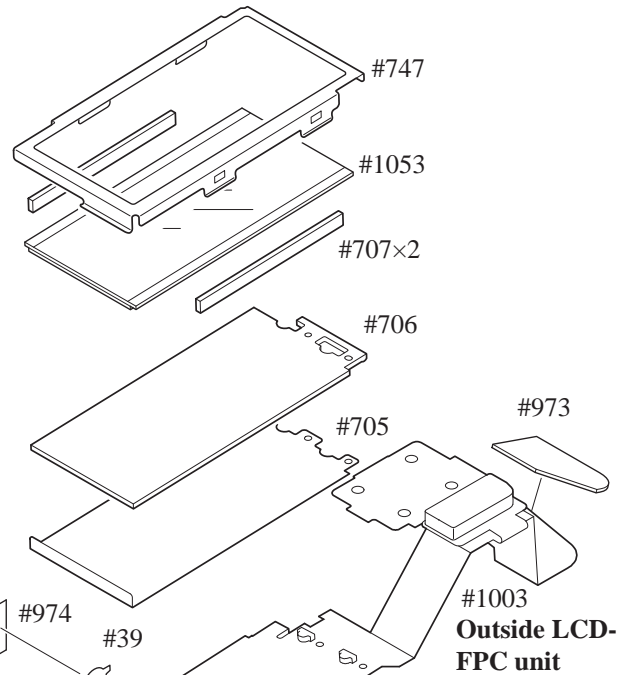

※ [#750] spring hooking position

Command dial, Shoe base and other small parts

Shoe base

- Fix the outside LCD FPC (#1003), top cover, and the shoe base firmly with four screws (#321).
- Solder [#1003] and [#B317].

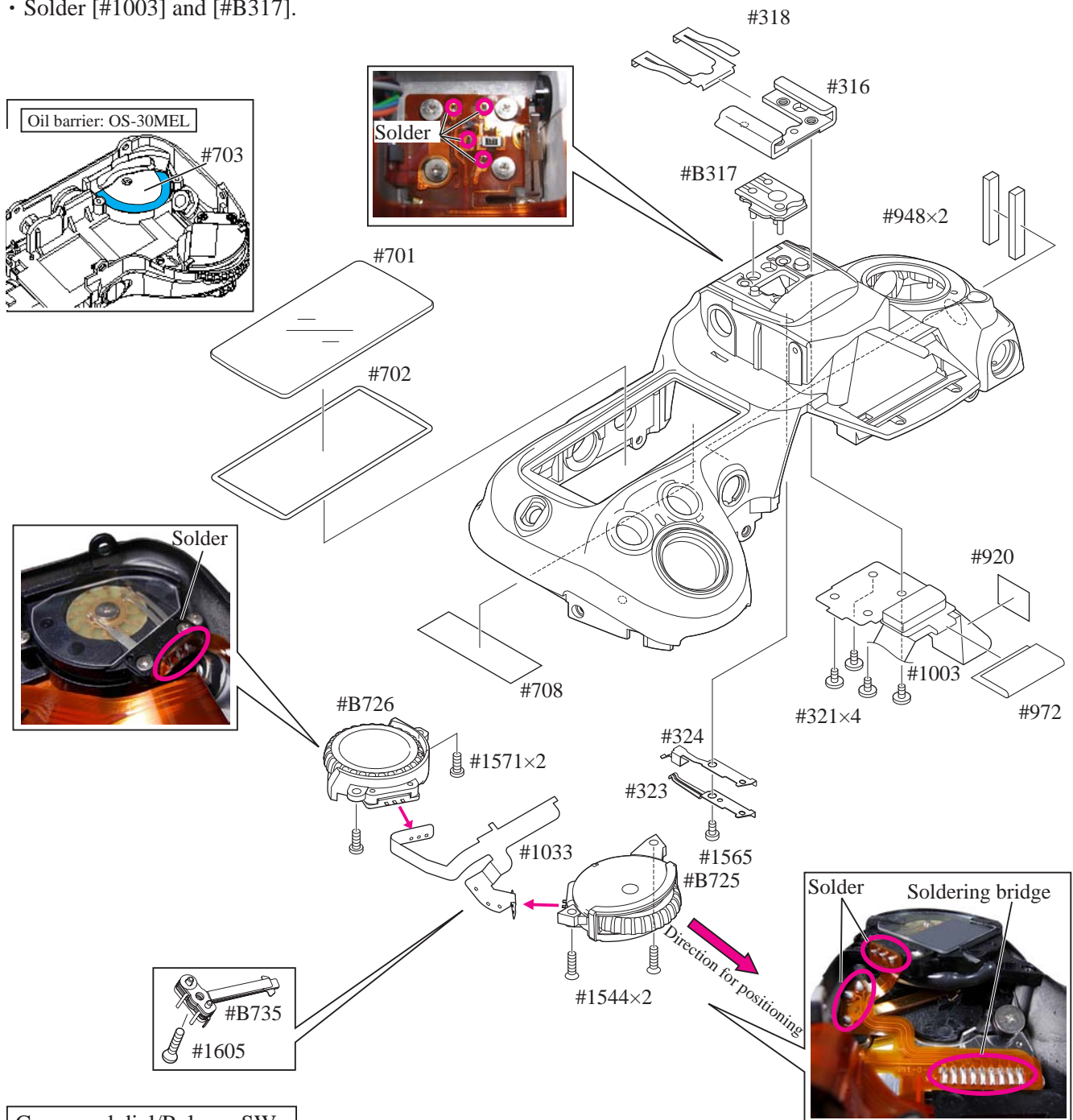

Command dial/Release SW

- Mount the rear command dial (#B726) on the top cover, and tighten two screws (#1571).
- Mount the front command dial (#B725) by positioning it forwards, and tighten two screws (#1544).
- Assemble the release contact-FPC (#1033) into the front command dial (#B725), rear command dial (#B726), release-SW (#B735), external LCD-FPC (#1003) in position, and solder them.

SB-PCB

- Solder the four wires on the SB-PCB (#1013).
- Attach the plate (#517) to the top cover, and tighten the screw (#1541).
- Mount the SB-PCB on the top cover, and tighten the screws (#1541, #1511, and #1535).
- As below, connect the FPC of the mode dial (#1025) to the connector.
- Solder the six SB wires and the synchro-terminal wire.

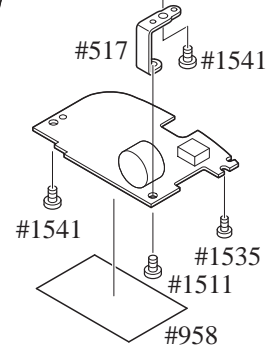
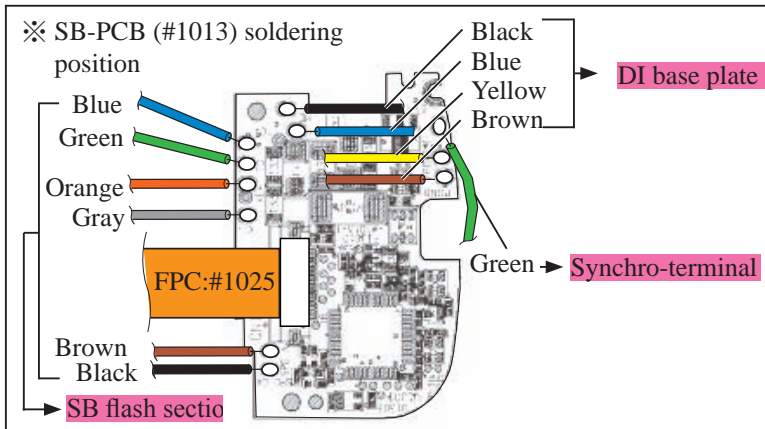
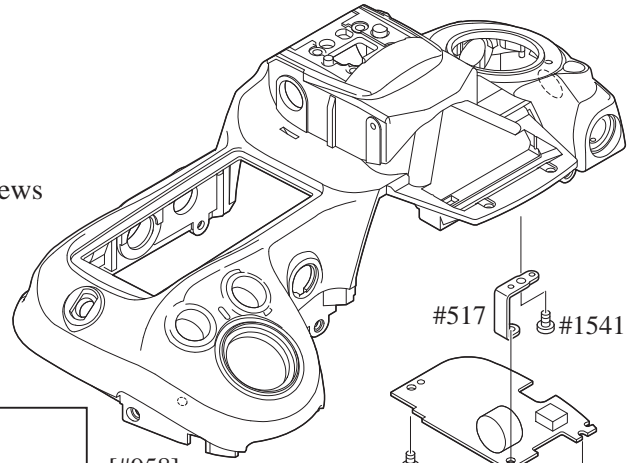

CF base plate, DR base plate and other small parts

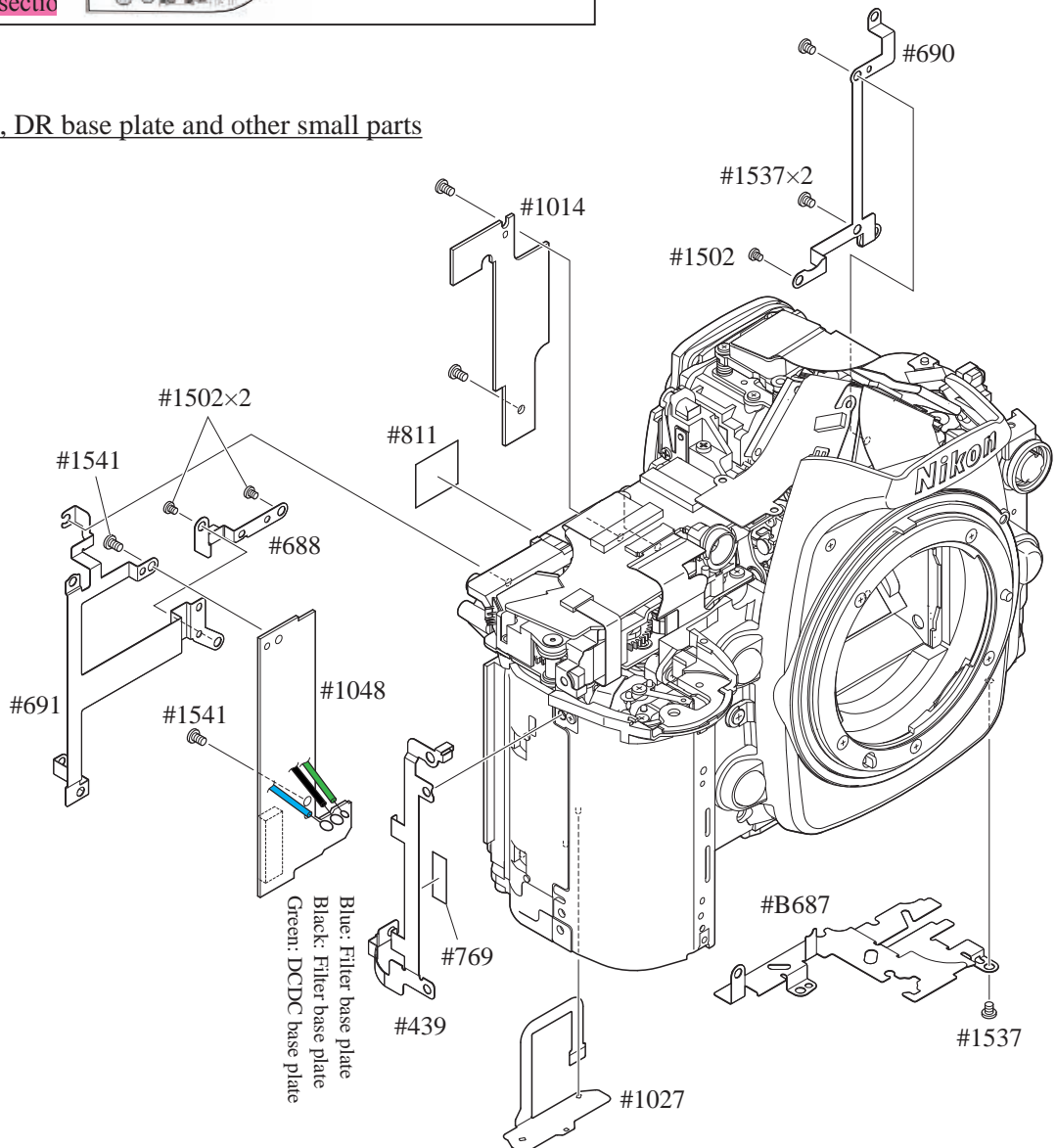

Whenever the metering FPC unit is disassembled or replaced, assemble up to the stage of PageA25 without mounting the top cover, and make the AE-CCD positioning adjustment.

Top cover unit

- Connect the connection-FPC of [#B23] to the connector of the body.
- Mount [#B23] on the body.
- ※ Be careful NOT to pinch wires.
- ※ Mount [#B23] with the flash unlock button (#40) being protruded outwards.
- Tighten two screws (#1548), two screws (#1511), two screws (#1547), and three screws (#1555).
- Attach the diopter adjustment drip-proof collar (#851), diopter adjustment drip-proof sponge (#857), and diopter adjustment knob (#852), and tighten the screw (#1622).
- Attach the diopter knob cover plate (#850).
- Solder the four wires of the top cover on the DI base plate (#1029) as below.

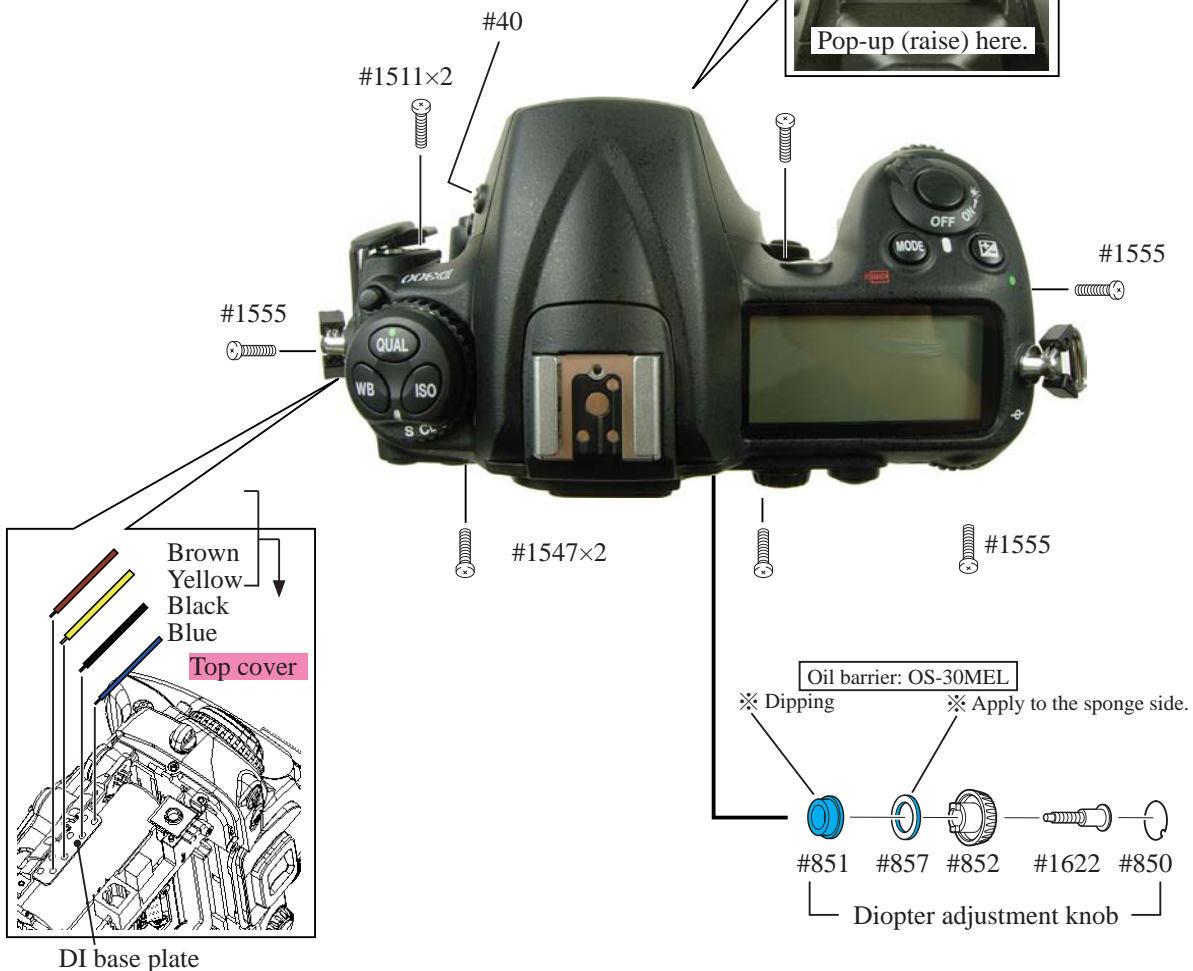
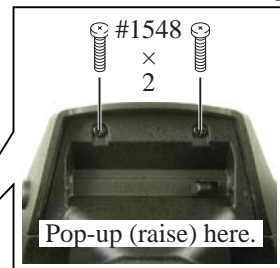
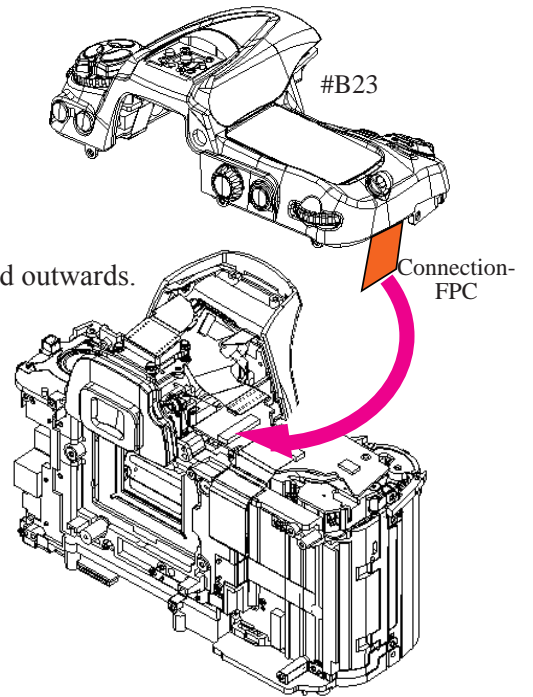
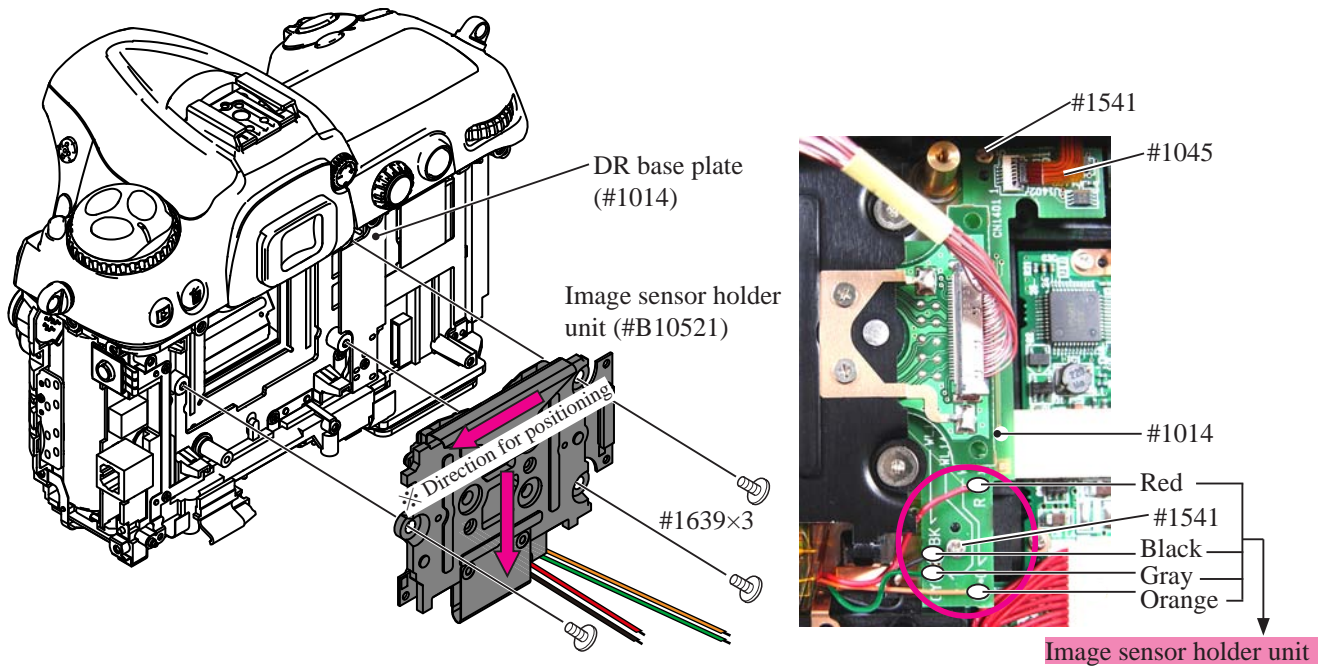

Image sensor holder unit

- Mount the DR base plate (#1014) on the body, and tighten two screws (#1541).
- Connect the FPC (#1045) to the connector of [#1014].
- Mount the image sensor holder unit (#B10521) on the body.
- Position [#B10521] in the direction of the arrow, and tighten three screws (#1639).
- Solder the wires of [#B10521] on [#1014].



CF base plate unit

- Connect the harness (#1074) to the connector of the DCDCSZ base plate (#1048).
- Connect the FPC (#1038) to the connector of the CF base plate (#1018).
- Mount the CF base plate (#1018) on the body, and tighten three screws (#1543).

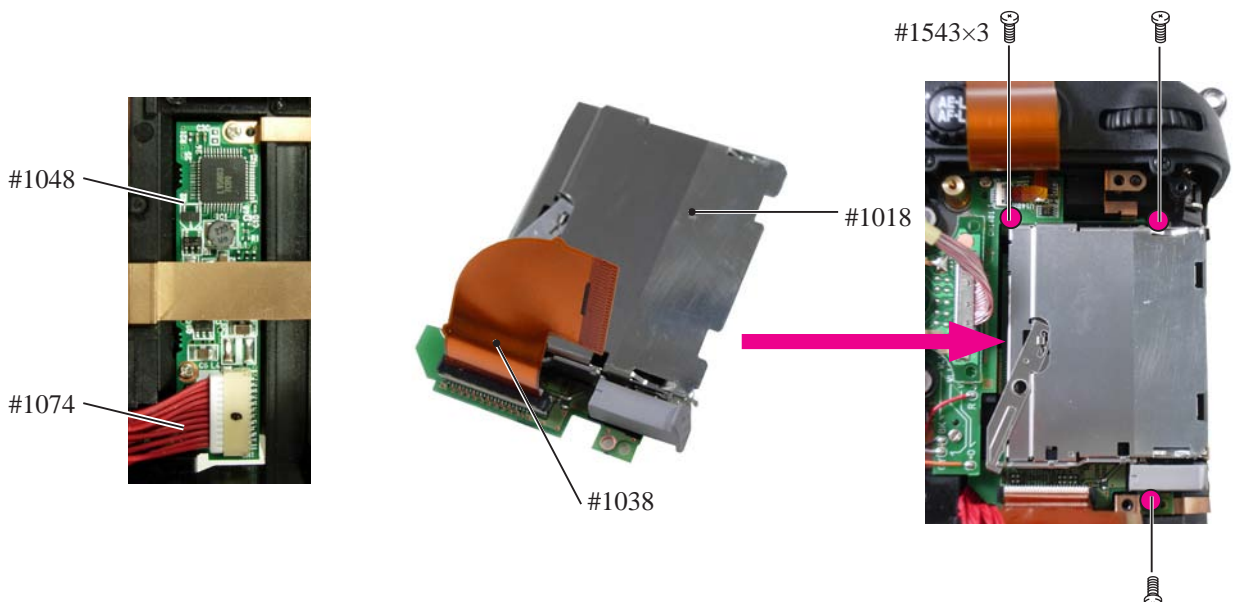

DG-PCB

- Mount the DG-PCB unit (#B11017) on the body.
- Tighten the screw (#1546).
- Connect the FPCs (#1027, #1038, #1039, #1040, and #1041) to each connector of the DG-PCB.
- Connect the harnesses (#1073, #1074, and #1075) to each connector of the DG-PCB.

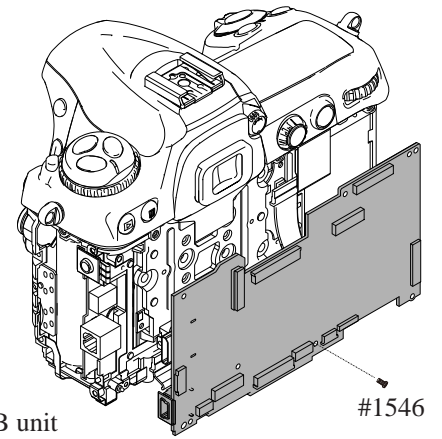
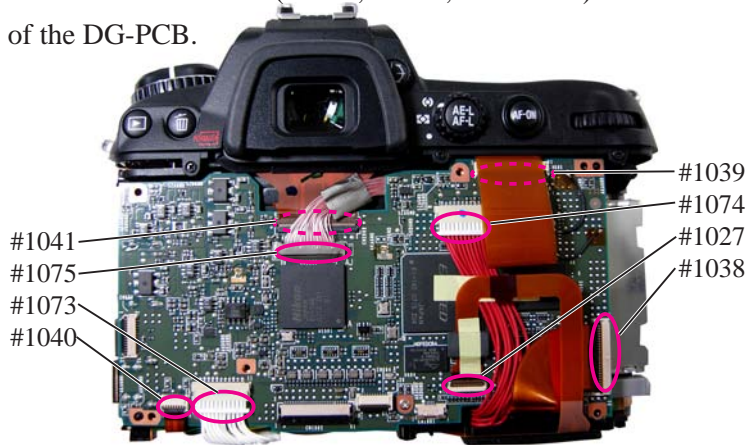

DG-PCB unit
(#B11017)

DG-PCB shield plate

- Mount the DG-PCB shield plate unit (#B683RP) on the DG-PCB.
- Tighten four screws (#1546) and two screws (#1515).
- Make soldering bridge to joint with the DG-PCB.

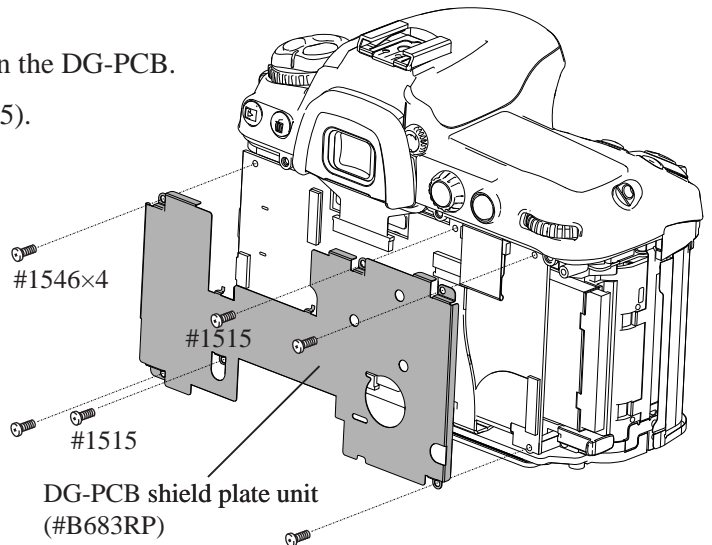
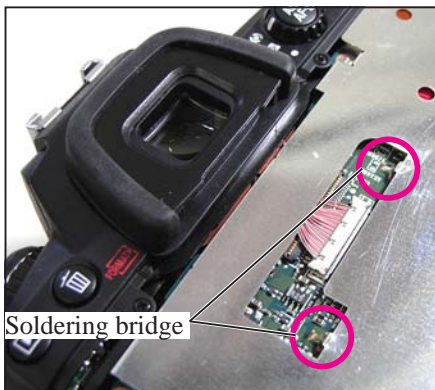

DG-PCB shield plate unit
(#B683RP)

I/F cover

- Mount the conduct plate (#695).
- Attach the I/F cover (#B28), and tighten two screws (#1510).

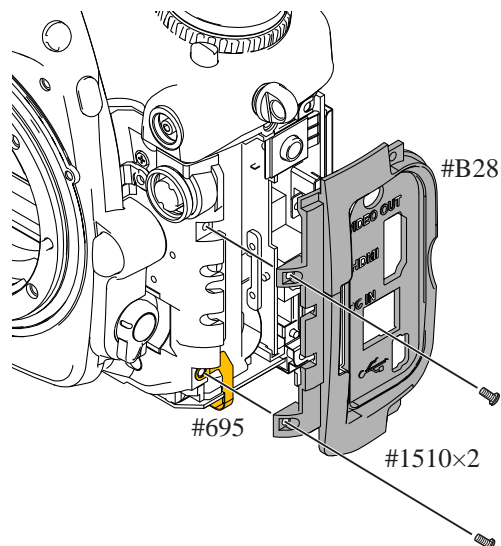

How to connect Camera and PC

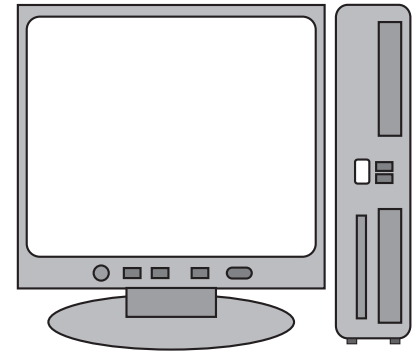

J18432 D300 Inspection and Adjustment software

Stabilized power supply
Set value = 7.4V 0.3Ω
5.0A
or AC adapter EH-5



Flashmeter
(not prepared as RJ)

Caution: When voltage is adjusted, use "MB-D10".
(Modify "MS-D10 size-AA battery holder, and connect the wires.)

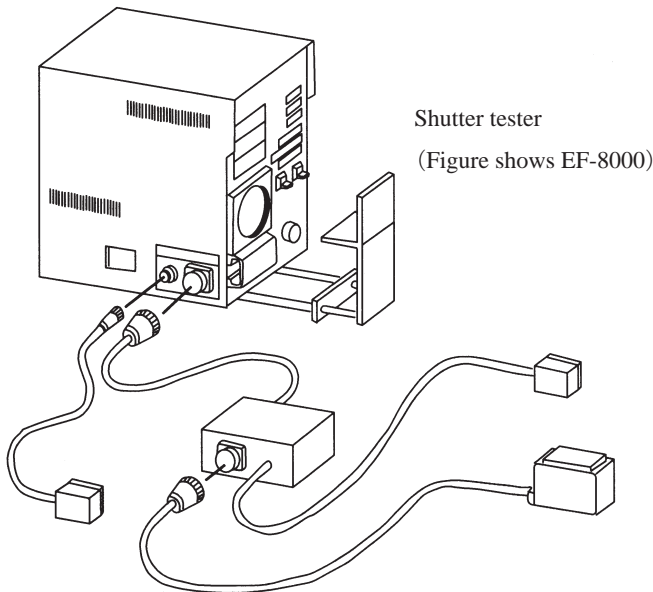

Shutter tester
(Figure shows EF-8000)

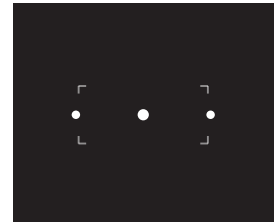

AE-CCD positioning tool
(J63100)
Set this in front of color viewer
(J63070).



Caution: When inspections/adjustments are made by using the shutter tester, turn the shutter tester to ON to light the lamp,
then perform the aging for 3-5 minutes.

Inspection and adjustment of AE CCD positioning

⚠ WARNING	
	<ul style="list-style-type: none"> ● Take extra care not to get an electric shock when detaching covers. ● After removing covers, be sure to discharge the main condenser according to the instructions of repair manuals.

- * Under the environment where the AE-CCD positioning is adjusted, use the reference body and confirm results.
- In case the measured value is out of standard, check whether there is no deviation of the focus area positioning.
 - In case the measured value is out of standard, change the environment of measurements. (e.g. setting place/direction, room brightness, etc)

Procedure

- ① Make temporary assembly of the grip cover, ~~IF cover~~^{△ (Deletion)}, and bottom cover (with the tripod base plate being attached) .
- ② Mount "AF50/1.4D" on the camera, and fix them on the tripod horizontally.
- ③ Connect the camera and PC via USB cable (UC-E4).
- ④ Connect the AC adapter EH-5.
* Be careful NOT to cause a short-circuit at uncovered portions.
- ⑤ Attach the AE-CCD positioning tool (J63100) in the color viewer (J63070), and turn power ON.
- ⑥ Keep the 0.7-m distance between the front face of the AE-CCD positioning tool and the reference surface of the camera. Set the camera AF to manual, and rotate the focus ring to set to "0.7 m".

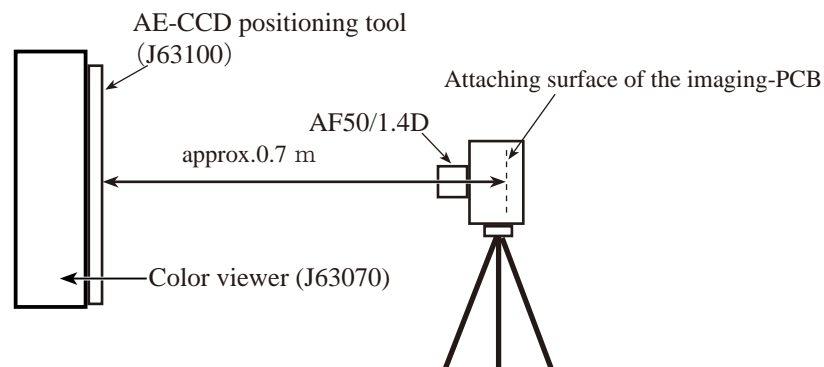

- ⑦ Start up the inspection and adjustment software for D300 (J18433), and select "Inspection and Adjustment for AE CCD POSITION" then "Set Camera for AE CCD POSITION" to lighten the focus area. Looking through the viewfinder, move the camera so that the focus area of the camera coincide with the grid lines of the AE-CCD positioning tool.
* Set the camera and AE-CCD positioning tool horizontally.
- ⑧ Select "Inspection and Adjustment for AE CCD POSITION".
* Cover the camera with a black cloth, etc, when measured.

- ⑨ Attach the metering FPC unit with three screws (#883) without tightening up them. Then give each screw one and half turns. By following the instructions of PC, adjust the position of "AE-CCD" with the screws (#883 ②, and #883 ③).

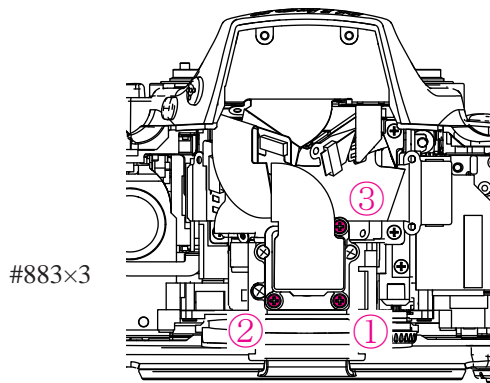

- Screw (#883) ① . . . Reference screw
- Screw (#883) ② . . . X-axis direction
- Screw (#883) ③ . . . Y-axis direction

- Because the screw ① is the reference screw, do NOT rotate it for adjustments unless absolutely necessary.

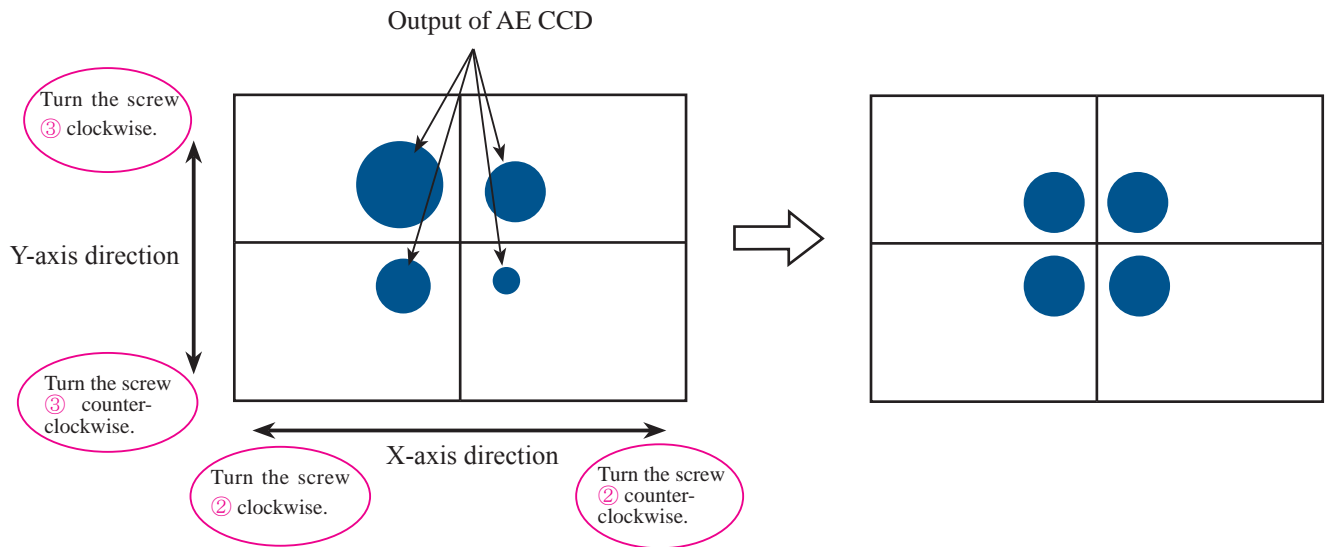

- ⑩ Fix the three screws (#883) with the screwlock.

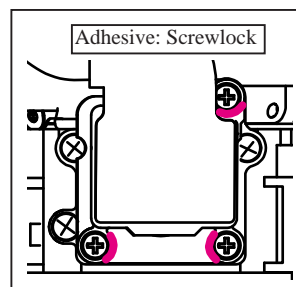

- ⑪ After completing the adjustment, fix the top cover with the screw and inspect the accuracy. If the result is out of standard, make readjustment.

Rear cover unit

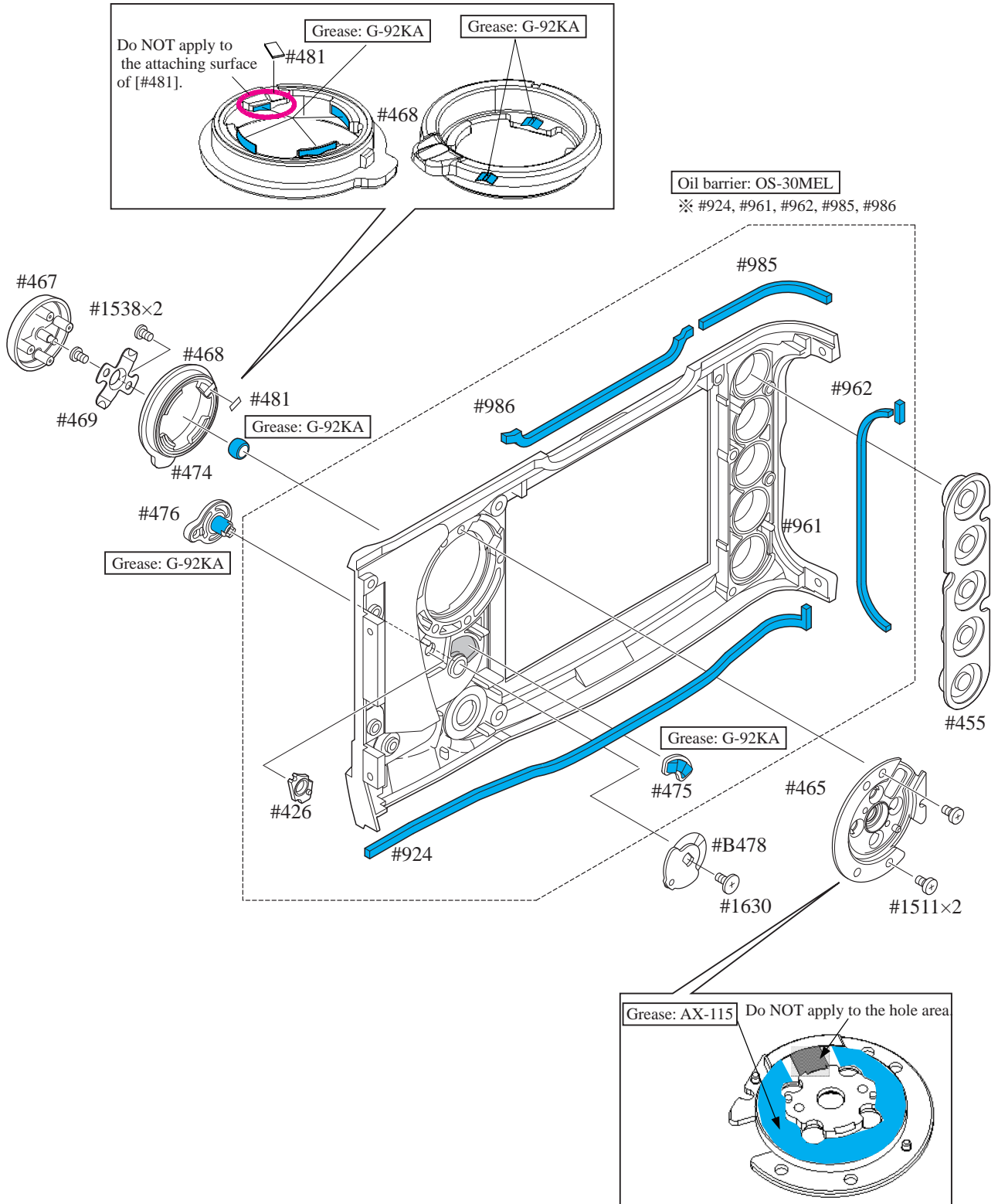

TFT monitor and other small parts

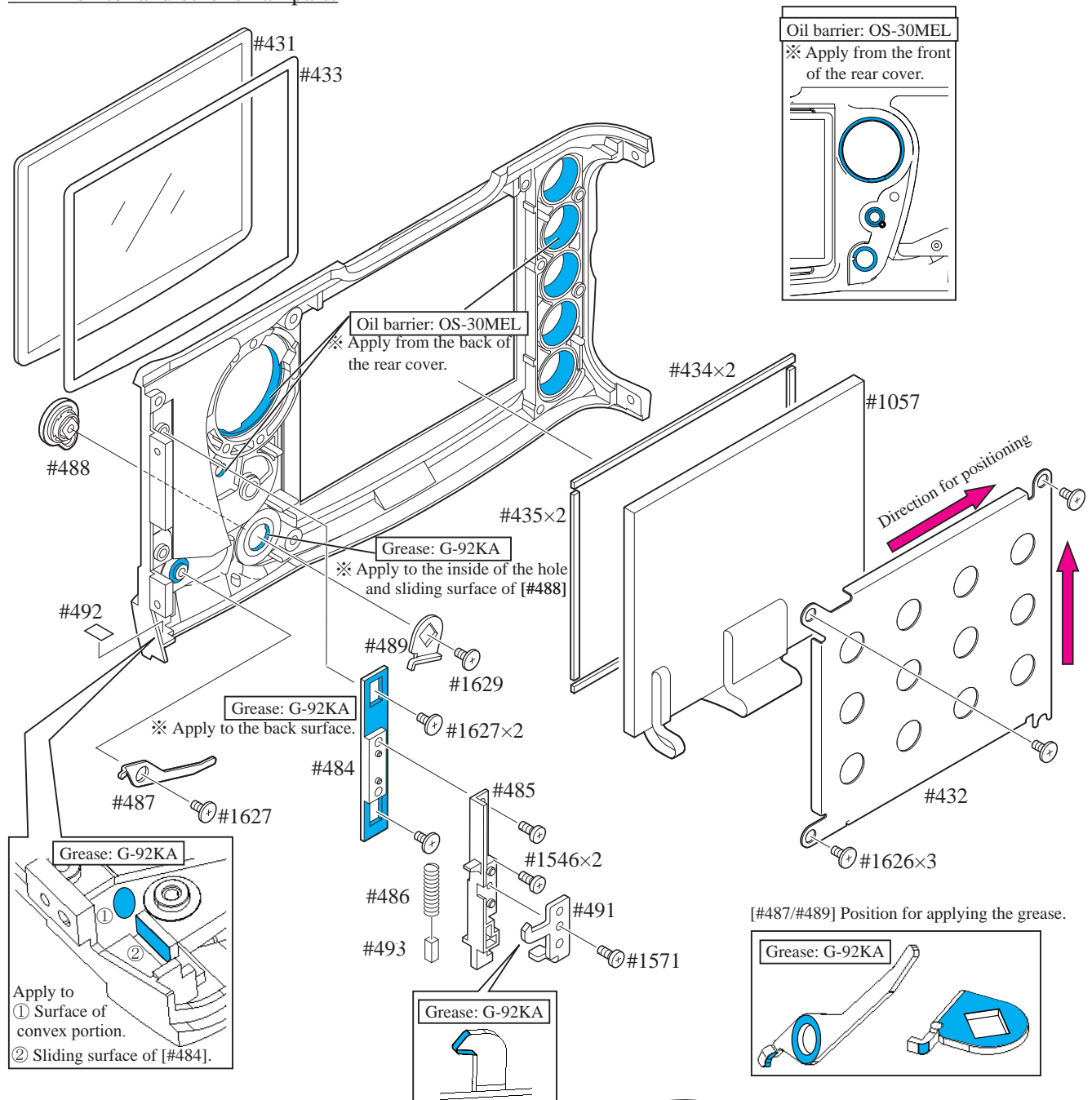

Rear-SW FPC, retainer plate, and other small parts

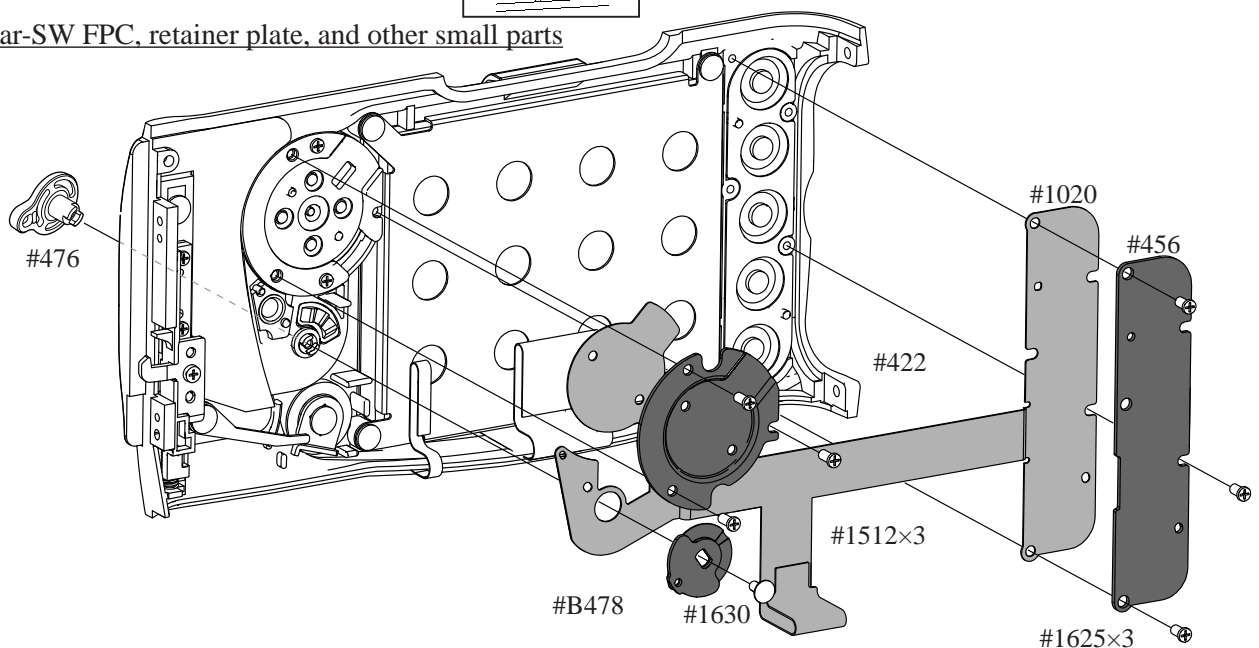

CF cover, Sponge and other small parts

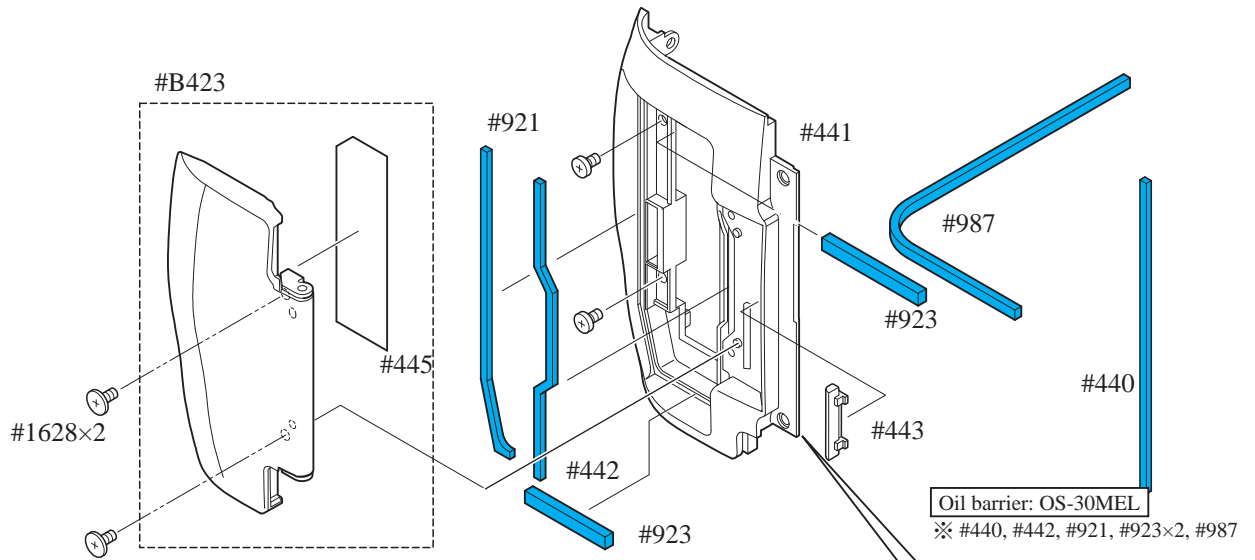

Installment of CF cover

- Tighten two screws (#1518).

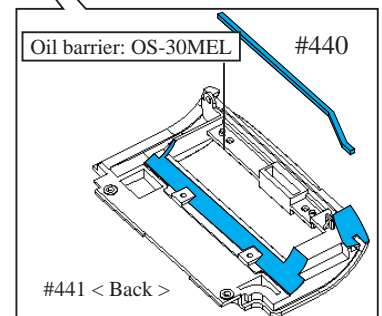
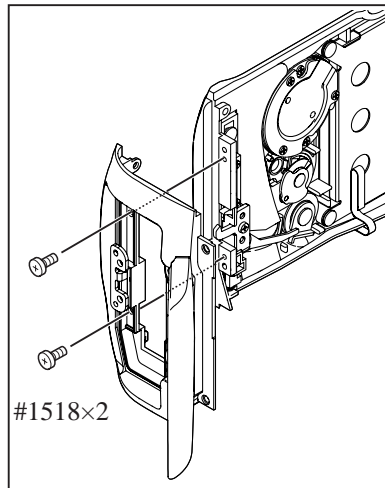

Installment of Rear cover unit

- Connect the three FPCs of the rear cover unit (#B10421) to each connector of the DG-PCB (#B11017) as below.
- Mount the rear cover unit on the body.
- Tighten one screw (#1551) two screws (#1547) and two screws (#1553).

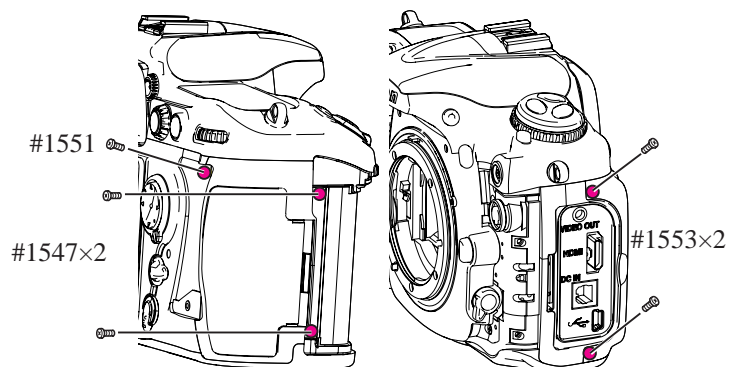

Bottom cover / Battery lid unit

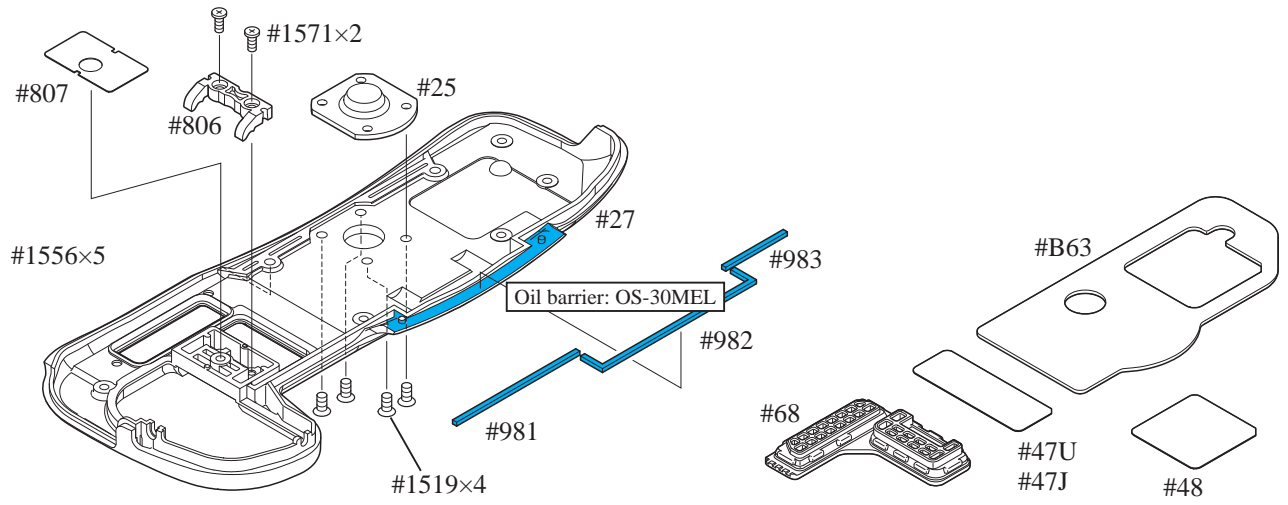

- Mount the bottom cover.
- Tighten three screws (#1550), five screws (#1556) and two screws (#1509).
- Mount the battery lid (#B801).

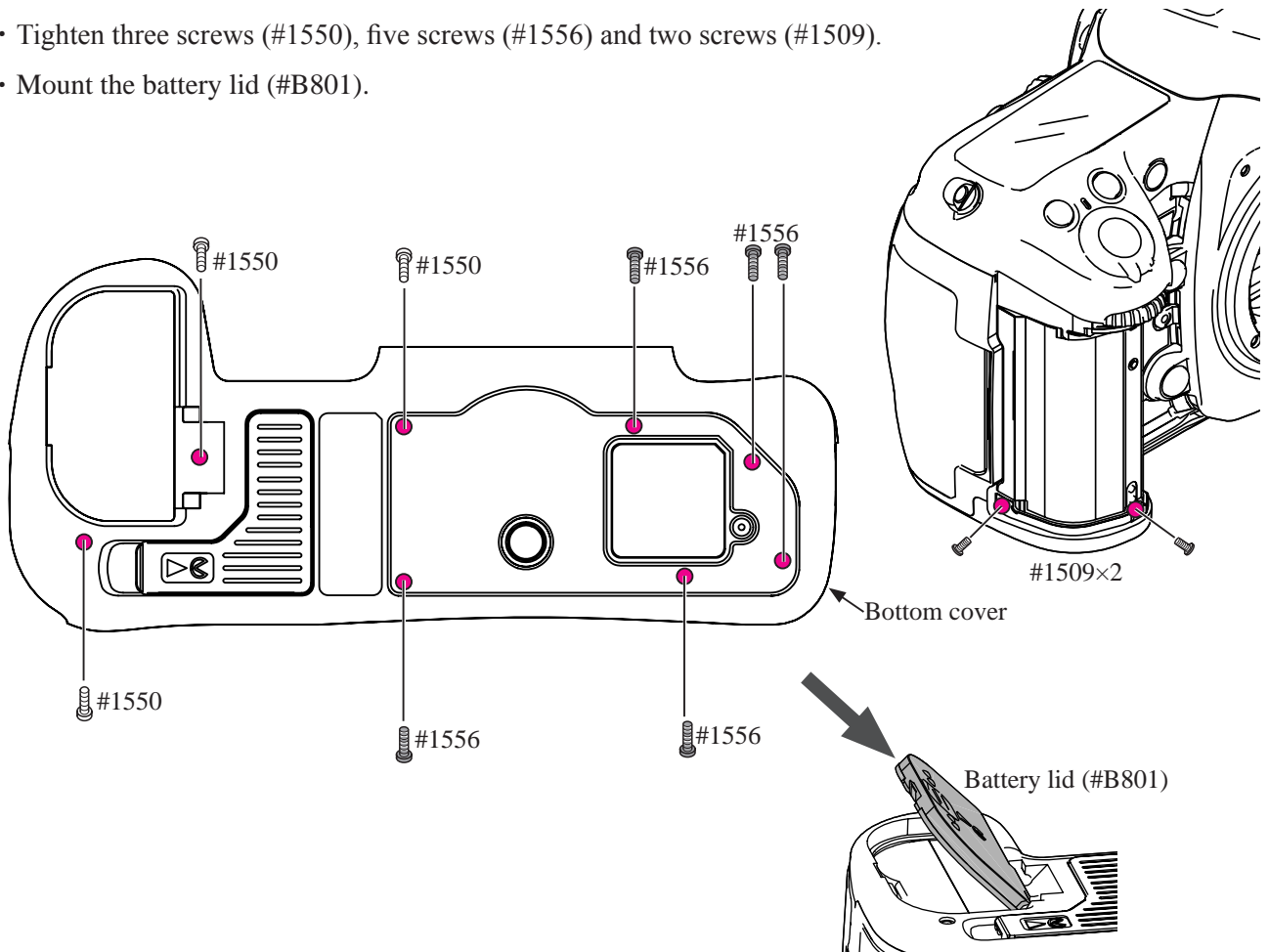

I/F rubber unit

- Mount the I/F rubber unit on the body, and tighten two screws (#1642).

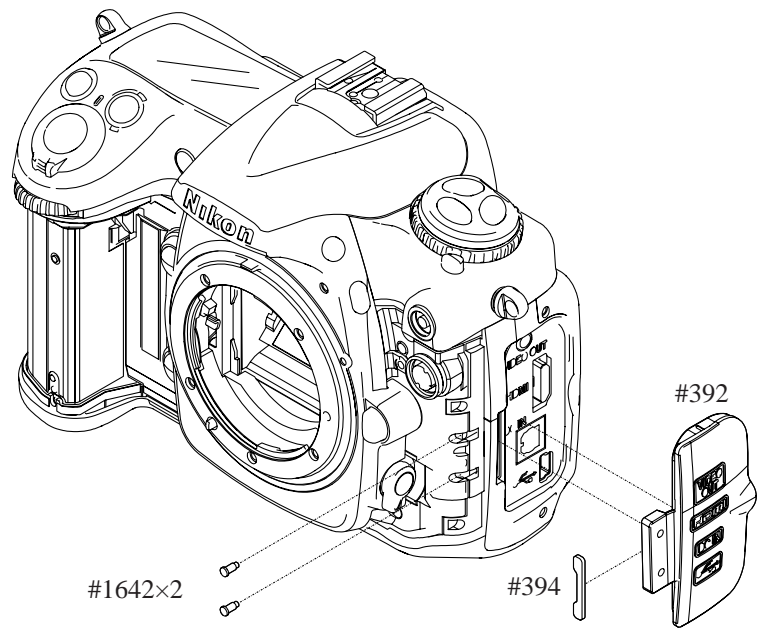

External rubber

- Attach the external rubbers (#B60, #B61, #B63, and #B447).
- Attach the grip rubber (#B60) firmly with the screw (#1647).

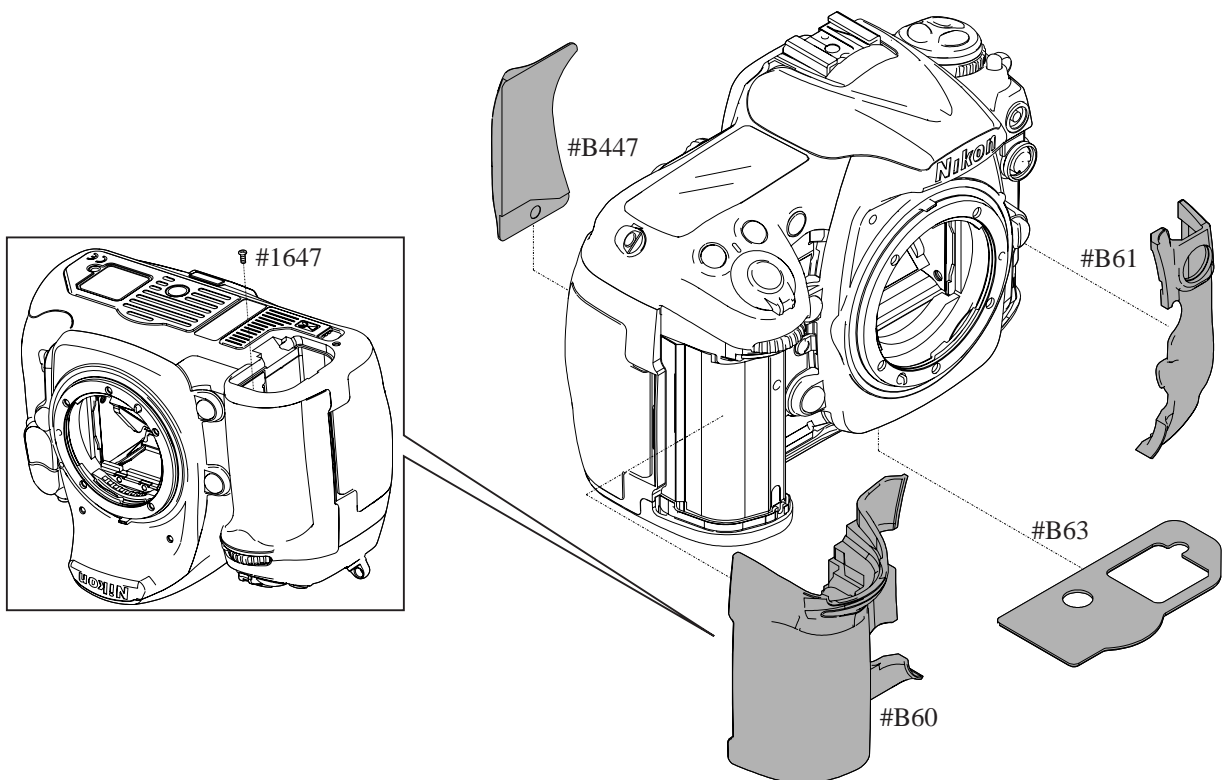

D300 Inspection and Adjustment Software (J18433)

This inspection and adjustment software runs on Windows.

Install the software by following the below procedure.

<Operating environment>

Check the following operating environment which is required for installing this program on PC.

PC	IBM PC/AT compatible
OS	Windows XP Professional Edition, Windows XP Home Edition, Windows Vista, Windows2000,
CPU	Pentium II 300MHz
RAM (memory)	256 MB or more
HD	6MB-or-more free disk space is required when installing
Monitor resolution	1024 × 768 pixels or more
Interface	※ USB interface (V1.1, 2.0) RS232C(com1 ~ com9)

As long as the above hardware requirements are met, any PC such as desktop or laptop, etc is available.

< Cautions in starting program >

When starting this program, close all the other applications.

If some other applications are running, this program may not be activated.

< File >

D300.exe	Application execution file
NkdPTP.dll	Library file: USB communication application extension file for Windows XP
NkdPTPDi.dll	Library file: USB communication application extension file for Windows 2000
PTPControl	Driver file storing folder for PTP: for Windows 2000
D300IA.ini	File for storing setting conditions of adjustment software

<Procedure for installation>

The file (D300Soft.EXE) of this program is provided via FD or e-mail.

Because this is the self-extracting file, decompress the file before installing, and follow the next procedure.

1. Create a folder for installation under any drive and name. C: ¥DeskTopLauncher\D-SLR\D300

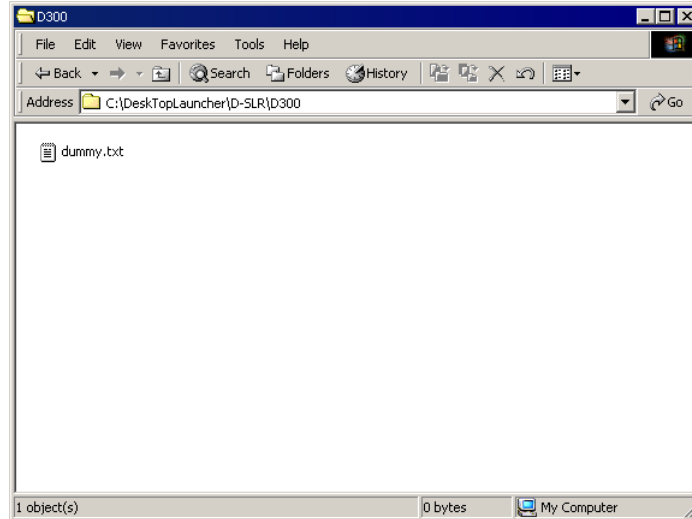

2. Paste the file (PD300.EXE) in the created folder.

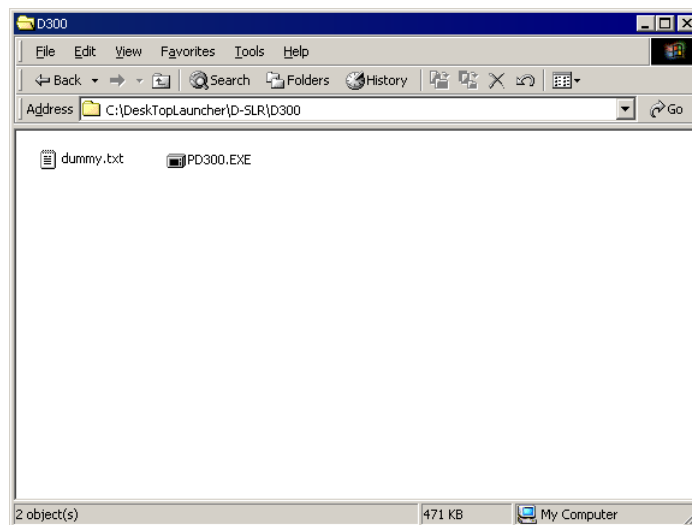

3. Double-click on the pasted file to display the following screen.

Press the OK button, then decompression starts.

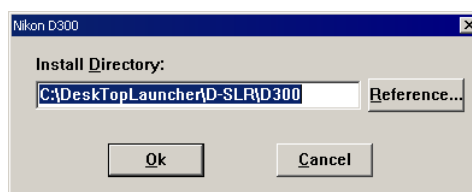

4. When the decompression of file is finished, the file (D300.exe) is created.

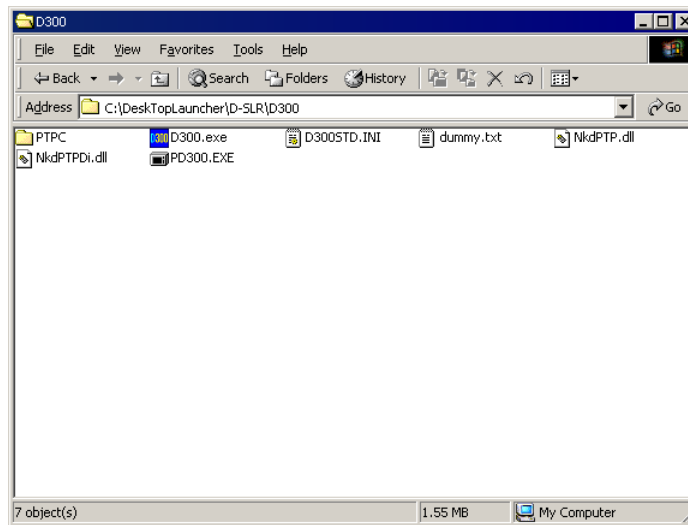

5. The install is completed.

< Procedure for installing USB driver >

If this program is used by the USB interface, installing the USB driver is necessary.

But if the OS is "Windows XP", the driver is already preloaded so it is not necessary to install it.

1. Set the USB of camera to "PTP".
(SETUP menu → USB setting → MTP/PTP)
2. Connect the camera and PC by USB cable.
3. Turn camera ON.
4. When "Add New Hardware Wizard" is displayed, click "Next".
5. Select "Search for a better drive than the one your device is using now. (Recommended)", and click "Next".
6. Click "Reference". Select "DeskTopLauncher\D-SLR\D300\PTPC\" of C drive, and click "OK".
7. The install is completed.

<Start-up of Program>

1. Double-click the file (D300.exe), then Inspection and adjustment program for D300 starts.

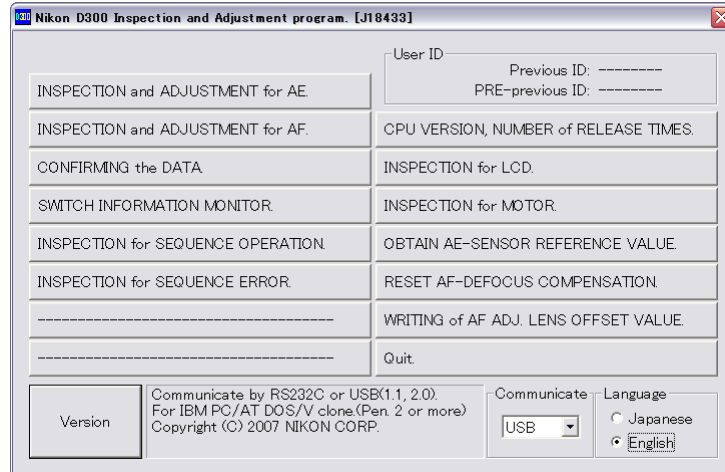

2. To display in Japanese, select the radio button "JAPANESE" in "LANGUAGE" in the lower right-hand corner of the screen.

However, this is not properly viewed in the English OS.



3. For "COM PORT" (communication port), the selection from "COM1" to "COM9" is available.

4. When the "Version" button at the lower-left is pressed, the program version will be displayed.

5. Select each item button according to operation.

Follow the instructions on the next screen that will be shown after pressing the item button.

6. To finish the program, press the "Close (×)" button in the right-hand corner of the screen or "QUIT".

AE inspection and adjustment

- ① AE CCD alignment inspection and adjustment (ref. Page A27 and 28 for details) 《USB connection communication》
 - ② AE accuracy inspection and adjustment 《USB connection communication》
 - ③ Aperture accuracy inspection 《USB connection communication》
 - ④ Built-in SB flash inspection and adjustment 《USB connection communication》
 - ⑤ Adjustment for battery check level (Use MB-D10 and stabilized power supply.) 《RS232C connection communication》
- [Tools required] ref. Page A26.

• AE accuracy inspection and adjustment

When AE accuracy inspection and adjustment are made,

The following types of lens (AF50/1.4D, AF28/2.8D, AF70-300/4-5.6D or AF-SVR70-300/4-5.6) are used.

Caution:

AE accuracy is not inspected by using the exposure value of the traditional shutter tester. The metering value is displayed on PC screen.

When AE sensor reference values are obtained, set the metering mode to “multi-pattern”.

• Battery check voltage level adjustment

Connect MB-D10 to the camera for the adjustment.

• Built-in SB flash inspection and adjustment

Set the distance between camera and flash meter to 1 m, and inspect and adjust the light volume of the built-in SB. (ref. adjustment software for details)

AF inspection and adjustment

《USB connection communication》

Note: When using the adjustment software for the first time, prepare three cameras of D300 and measure by "WRITING of AF ADJ. LENS OFFSET VALUE" on the main menu.

- ① AF accuracy adjustment (Make the overall following adjustment.)
- ② YAW, PITCH inspection and adjustment
- ③ X/Y inspection and adjustment
- ④ LARK adjustment (inc. CCD output adjustment)
- ⑤ AF shift adjustment

[Tools required]

• When adjusting for all adjustment items

ref. Page A26.

1. When inspecting AF accuracy

- ① AF adjustment lens (J18266)
- ② AF adjusting tool (J15259)
- ③ Lens holder for F4 (J15280)
- ④ AF chart (J18344)
- ⑤ Chart illuminator for AF (J15264)

2. When adjusting YAW, PITCH

YAW, PITCH tool (J18230)

3. When inspecting/adjusting X/Y

AF X/Y chart (J63101)

4. When adjusting LARK

The above tool when inspecting AF accuracy

5. AF shift adjustment

The distance from the bayonet reference plane to the imaging area (CCD) is calculated by the actual shot photo, and its error is recorded in EEPROM as compensation amount, and adjusted.

∞ Infinity focus inspection & adjustment

- Replace the finder screen with the infinity focus check screen (J18394), and use the reference lens (J18010) and read the value. In case it is out of standard, increase or decrease washers (#836A, #836B, #836C or #836D) for adjustments. * Supply the power (Battery or EH-5) for checking.

Caution: When [J18394] is put in to replace the finder screen, put it with the silver spacers upward, which are attached on both sides.

J18010

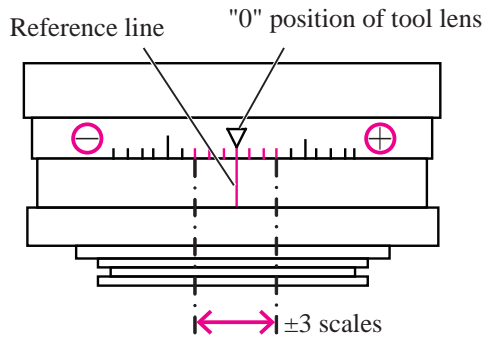

Standard: ±0.03mm (1 scale = 0.01mm)

#836A	1K608-832	Screen washer A	0.10mm
#836B	1K608-833	Screen washer B	0.20 mm
#836C	1K602-840	Screen washer C	0.15mm
#836D	1K608-977	Screen washer D	0.05mm

Necessary adjustments when parts are replaced

1. D300 adjustment software and updates

Adjustments Replacement parts	Writing of EEPROM fixed values	AE CCD positioning adjustment	AE accuracy inspection & adjustment	Aperture accuracy inspection	Built-in SB light volume inspection & adjustment	Battery check voltage level adjustment	AF accuracy inspection & adjustment
* 1 Shutter unit							
* 2 Main PCB unit	○	* 3 △	○	○	○	○	○
AF FPC unit							○
Top cover or SB lower case unit					○		
DCDCAK base plate unit						○	
DCDCSZ base plate unit							
Metering FPC unit		○	○				
I base plate unit				○			

* 1. When the shutter is replaced, make the image shutter adjustment by using the image adjustment software.

* 2. When the main PCB unit is replaced, be sure to update the version before writing the fixed values:
△ (Revision) update the firmware after "writing of fixed value", and then perform "writing of fixed value" again.

* 3. Make the inspection.

2. Shooting image adjustment software and Software updates

Adjustments Replacement parts	Serial No. input	QR code data input * 3	GrGB differ. comp. adj. (G filter)	Dark current adjustment	Sensitivity adjustment	Shading adjustment	Gr/Gb compensation adj. (R/B filter)	Sensitivity ratio adjustment	Image shutter adjustment	Pixel defect compensation (black)	Pixel defect	TFT adjustment	Initial settings (Factory default settings)	Version No. / Serial No.
Shutter unit									○					
Main PCB unit									○					
AF FPC unit														
DCDCAK base plate unit														
DCDCSZ base plate unit														
Metering FPC unit														
* 1 DG-PCB unit * 2	△ (Addition) ○	○	○	○	○	○	○	○	○	○	○	○	○	○
Image sensor holder unit * 2	△ (Deletion) ⊖	○	○	○	○	○	○	○		○	○			
TFT monitor												○		
License sheet														○

*1. When the DG-PCB unit is replaced, be sure to update the firmware before writing the fixed value.

*2. When the DG-PCB unit or the image sensor holder unit is replaced, take a picture of the QR code area before assembly. Then when the adjustment is made, read the QR code with the barcode reader based on the image adjustment software, and input the data.

*3. There is no menu screen, but when "GrGB differences compensation adjustment (G filter)" is performed, the serial number and QR code data will be input by selecting either the DG-PCB or image sensor holder unit replacement.

Shooting Image Adjustment

1. Summary

When D300 shooting image-related and listed parts on Page A42 are replaced, be sure to make an adjustment by the shooting image adjustment software for D300 (J65107). The details of its function and how to use this software are as follows:

2. Adjustment software function

- (1) Gr/Gb difference compensation adjustment (G filter)
- (2) Dark current adjustment
- (3) "Sensitivity" adjustment
- (4) Shading adjustment
- (5) Gr/Gb compensation adjustment (R/B filter) / Line crawl adjustment
- (6) "Sensitivity ratio" adjustment
- (7) Image shutter inspection and adjustment
- (8) Pixel defect compensation - black point
- (9) Pixel defect compensation - white point
- (10) TFT adjustment
- (11) Obtain reference value
- (12) Initial settings (factory default settings)
- (13) Confirm adjusting data
- (14) Version No./ Serial No.

※ When the adjustments from (1) to (6) are made, get in advance the reference values of (11) by using the reference body, then perform the adjustments.

3. Hardware requirements

- OS : Windows2000, WindowsXP, Windows VISTA
Japanese or English OS
- PC : CPU Pentium II or more
Memory 256MB or more
USB1.1 or 2.0
- Screen size: 1024×768 pixels or more

4. How to set up

Create "C:\DeskTopLauncher\D-SLR\D300IMG" folder is created in the harddisc (except desk top) of PC, so copy "PD300IMG.EXE". This file is a self-extracting file, so decompress it in the created folder.

※ Be sure to copy the above file in the same directory.

5. Basic usage

- (1) Execute "D300IMG.exe" to start up the main screen. (ref. Fig.1)
- (2) Select ENGLISH / JAPANESE in Language to display the appropriate menu. (ref. Fig.2)
- (3) Click the button to start adjustments.
- ※ When the adjustments from 1. to 6. are made, calculate to get the "Sensitivity" and "Sensitivity ratio" reference values by using the reference body beforehand, then perform the adjustments.
- (4) Follow the instructions on screen.
- (5) To complete the procedure, click "QUIT" button or "X" button at the upper-right corner of the menu.

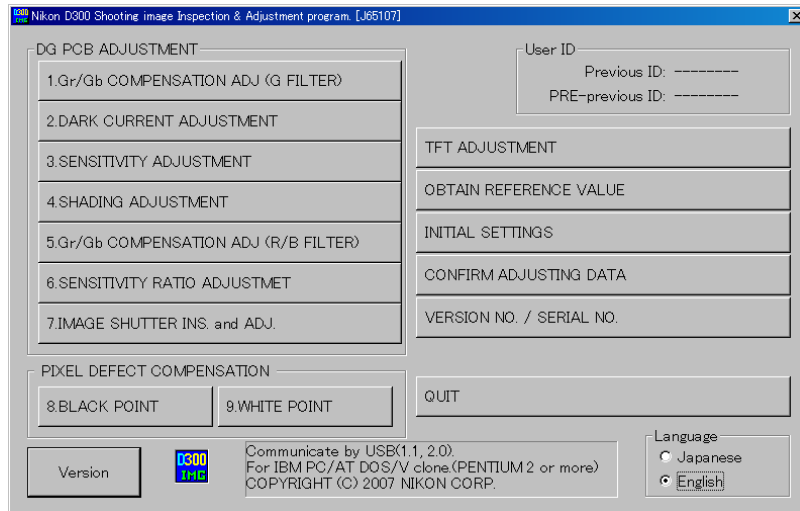

Fig.1

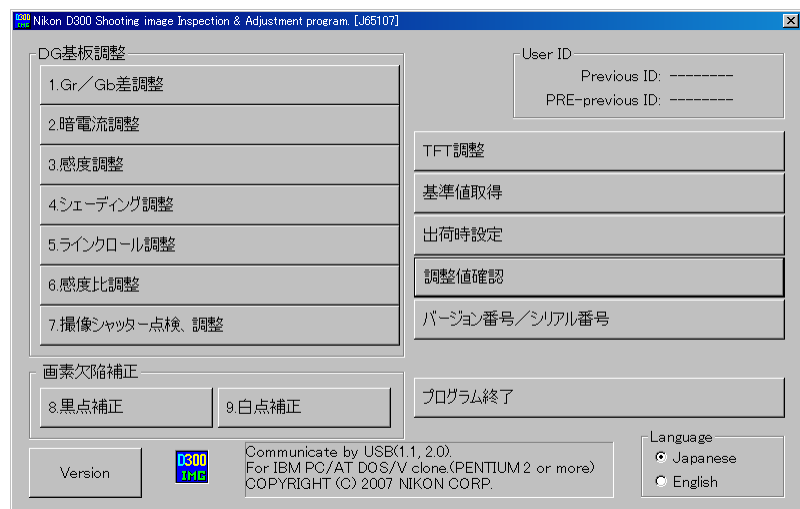

Fig.2

6. Required device and conditions

※ AC adapter EH-5 and USB cable (mini B type) UC-E4 are used for all adjustments so they are not particularly mentioned in the list.

★ New tool

	Item	Required device	Setting/Remarks
1	Gr/Gb difference compensation adjustment (G filter)	<ul style="list-style-type: none"> • 5100K color viewer J63070 (ex-model viewer J63049 is also available.) • Luminance meter BM-3000 J63068 • Tool lens (to fix aperture) J61185 • SP2 (G filter) J63086 	Luminance LV13 equivalent Aperture F5.6
2	Dark current adjustment		Body cap Eyepiece cap or black cloth
3	Sensitivity adjustment	<ul style="list-style-type: none"> • 5100K color viewer J63070 (ex-model viewer J63049 is also available.) • Luminance meter BM-3000 J63068 • Tool lens (to fix aperture) J61185 • ND filter • ND filter (ND8×2) 	Luminance LV13 equivalent Aperture F8 Use a commercial product; 6-step light reduction
4	Shading adjustment	<ul style="list-style-type: none"> • 5100K color viewer J63070 (ex-model viewer J63049 is also available.) • Luminance meter BM-3000 J63068 • Tool lens (to fix aperture) J61185 • ND filter (ND4×2) 	Luminance LV13 equivalent Aperture F5.6 Use a commercial product; 4-step light reduction
5	Gr/Gb compensation adjustment (R/B filter) / Line crawl adjustment	<ul style="list-style-type: none"> • 5100K color viewer J63070 (ex-model viewer J63049 is also available.) • Luminance meter BM-3000 J63068 • Tool lens (Fixed aperture) J61185 • SP3 (R filter) J63087 • SP1 (B filter) J63085 	Luminance LV13 equivalent Aperture F5.6
6	Sensitivity ratio adjustment	<ul style="list-style-type: none"> • Shutter tester • Luminance meter BM-3000 J63068 • Tool lens (to fix aperture) J61185 • 5100K color viewer J63070 (ex-model viewer J63049 is also available.) 	Luminance LV9 Aperture F5.6; No filter Inspection luminance LV13 equivalent
7	Image shutter inspection and adjustment	<ul style="list-style-type: none"> • Shutter tester • Luminance meter BM-3000 J63068 • Tool lens (to fix aperture) J61185 	Luminance LV9,15 Aperture F5.6
8	Pixel defect compensation - black point	<ul style="list-style-type: none"> • 5100K color viewer J63070 (ex-model viewer J63049 is also available.) • Luminance meter BM-3000 J63068 • Tool lens (to fix aperture) J61185 	Luminance LV13 equivalent Aperture F5.6
9	Pixel defect compensation - white point	Body cap or Lens cap	Environmental temperature approx. 20 - 25°C
10	TFT adjustment	None	No filter when sensitivity ratio reference value is calculated.
11	Obtain reference value	Same as "Sensitivity adjustment" and "sensitivity ratio adjustment"	
12	Initial settings (factory default settings)	None	
13	Confirm adjusting data	None	
14	Version No./ Serial No.	None	

7. Summary

The summary on each adjustment is as follows:

(1) Gr/Gb difference compensation adjustment (G filter; G-line crawl only)

- When the DG-PCB is replaced, write the serial number.
- When the DG-PCB or image sensor holder unit is replaced, write the unique data.

First, take a picture of the QR code that is attached to the image sensor holder unit, then read the shot image with the hand scanner. Write "D300_0001 ~ .csv" data in the DG-PCB.

※ The data will be added every two weeks (e.g. D300_0001.csv, D300_0002.csv, D300_0003.csv...), so copy this added file to the same folder of the adjustment software.

Camera is faced to the light-emitting box (color viewer) of LV13 equiv. with SP2 (G filter) being put between them. G-line crawl (3895×2610 pixels) is divided into (29×25) blocks, and the adjustment is made so that the difference between Gr and Gb output can fall in the standard range.

(2) Dark current adjustment

Take a picture of the blackout surface (against dark background) and adjust the shooting conditions in total darkness. ※ When the adjustment is made, use eyepiece cap (or black cloth).

(3) Sensitivity adjustment

Camera is faced to the color viewer of LV13 equiv. with ND filter (-6 steps) being put between them, and the adjustment is made by changing the amp gain so that G output can fall in the standard range. The gain value is adjusted so that the G output average value (Average of Gr/Gb) of (425×425 pixels), which was deviated to the right from the center by 425 pixels, can reach the target output level (approx. 750LSB).

The actual adjustment of the gain value is made only under the condition of ISO200 and ISO1600, and the medium sensitivity is calculated by the adjustment values of these 2 conditions.

For target output level, G output average of sensitivity reference value (ISO200) is used, which was calculated by the reference body.

(4) Shading adjustment (5100K color viewer is shot by this camera, and adjustment is made.)

Camera is faced to the color viewer of LV13 equiv. with ND filter (-4 steps) being put between them, and the adjustment of white balance distribution is made for 3 areas [Area ① : Central 2128×1416-pixel area; Area ② : All the divided areas except ③ -areas after dividing (4298×2606-pixels) into (30×25-pixels); Area ③ ; 4 corners of (4×6-pixels) after dividing (4298×2606-pixel) into (30×25-pixels)]

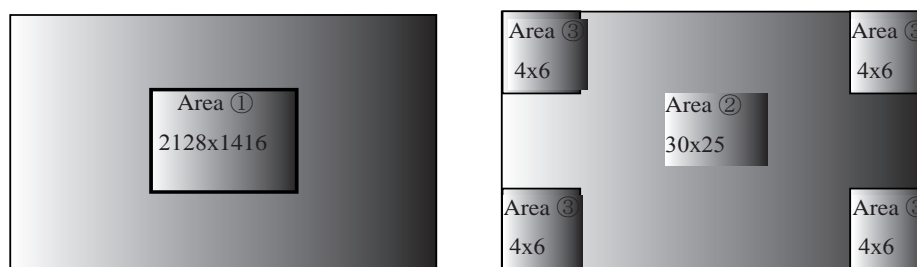

(5) Gr/Gb compensation adjustment (R/B filter) / Line crawl adjustment

Camera is faced to the light-emitting box (color viewer) of LV13 equiv. with SP3 (R filter) or SP1 (B filter) being put between them, and the adjustment is made so that the difference in G output average between B-G line and G-R line when the whole screen is divided in areas, can fall in the standard range.

(6) Sensitivity ratio adjustment

With the shutter tester of LV9, the adjustment is made so that the R/G, B/G output becomes the same as the output ratio of the sensitivity ratio reference value that was calculated by the reference body. The adjustment is made only under the condition of ISO100, and the average value of (425 pixels × 425 pixels) which was deviated to the right from the center by 425 pixels is used.

(7) Image shutter adjustment

Based on the 1/125 sec. data of LV9, fine-tune the 1/8000 sec. data of LV15. After the adjustment, inspect the data deviation at nine points of the shot image.

(8) Pixel defect compensation - black point

When pixels of which the output level is under specified value with LV13 equiv. are detected, the coordinates of the detected pixels are additionally written as pixel defect compensation data.

(9) Pixel defect compensation - white point

Shots are taken on the blackout surface (against dark background). In case the pixel output is found to be beyond the standard value, the detected pixel coordinates are additionally written as the pixel defect compensation data.

(10) TFT adjustment

Flickering, color and luminance of TFT are adjusted.

※ Whenever the DG-PCB or TFT monitor are replaced, be sure to perform "WRITING THE TFT FIXED VALUE."

(11) Obtain reference value

• Sensitivity reference value calculation

The reference body is faced to the color viewer of LV13 equiv. with the ND filter (-6 step) being put between them. Then, the G output average value of (425 pixels × 425 pixels), which was deviated to the right from the center by 425 pixels, is stored in the D300BSD.DAT file as the sensitivity reference value.

• Sensitivity ratio reference value calculation

The reference body is faced to the shutter tester of LV 9 equiv. (without filter) and LV13 equiv. (without filter). Then, the sensitivity ratio reference value GR and GB are calculated and stored in the D300BSD.DAT file, based on the G/R/B output average of (425 pixels × 425 pixels), which is deviated to the right from the center by 425 pixels.

※ It is necessary to calculate the reference values of "Sensitivity" and "Sensitivity ratio" in order to prevent the color temperature fluctuation caused by color viewer's changes over time from affecting the results of the shooting image adjustment. By using the reference body, calculate the reference values once in about every 3 months, when the fluorescent of the color viewer is replaced.

The reference value file "D300BSD.DAT" will be created after getting the reference values.

(12) Initial settings (Factory default settings)

By reset the settings of camera, factory default settings are restored.

Select the language and video mode. Because this setting of RP DG-PCB is blank, be sure to set the initial default setting when the DG-PCB is replaced.

(13) Confirm adjusting data

Saving/restoring of the system fixed values, image register, TFT register, EEPROM1, 2, 3.

The functions of saving/restoring each data is for sending backup data to Service Planning for analysis, if some problem occurs.

(14) Version No./ Serial No.

RISC firmware version is indicated.

Body serial number is also indicated.

• Whenever the DG-PCB unit or license sheet is replaced, input and change the serial number.

8. Procedure

8-1. Shooting image adjustment

- Calculate the "Sensitivity" and "Sensitivity ratio" reference values by using D300 reference body beforehand, then perform the adjustments. (ref. 9-4.)
- For shooting image adjustment, make all items from (1) to (7). The adjustments from (1) through (7) are all programmed to be executed in serial order. When 1 item is completed, the software automatically goes on to the next adjustment.
- In case adjustments are interrupted by NG, the adjustments can be continued again after NG. As for adjustments that were ended with OK, the flash memory updates of the adjustment value are completed.

Note: Adjustments are not possible without resetting "Custom setting" of this camera.

Before the adjustments, record the details of "Custom setting" set by customers if necessary.

Start adjustments

- Provide the power for the camera via AC adapter.
- Reset "Custom setting".
- Set "PTP" mode by Setup menu.
- Set the focus mode to "M", exposure mode to "M", and the exposure compensation to "0" of the camera.
- Connect the camera and PC via USB cable.
- Set the luminance of the color viewer to LV13 equivalent.
- Set the shutter tester to LV9.

(1) Gr/Gb difference compensation adjustment (G filter)

- Writing of the image sensor unique data

Based on the procedure of the image adjustment software, read the shot QR code on the playback screen with two-dimensional barcode reader and write the image sensor-unique data into the DG-PCB.

※ Set the settings of the two-dimensional barcode reader. (ref. Page A53)

※ BEFORE assembly, take a picture, with a digital camera, of the QR code that is attached to the FPC of the image sensor holder unit.

- When the image sensor holder unit is replaced, or the DG-PCB unit and the image sensor holder unit are replaced, take a picture of the QR code of the image sensor of RP.
- When the DG-PCB unit is replaced, take a picture of the QR code of the image sensor holder unit that is attached to the body.

【Shooting condition】

Compact digital camera is used:

- Quality: FINE
- Size: 3M
- Shooting mode: BSS
- AF mode: Closeup mode
- SB mode: Flash cancel

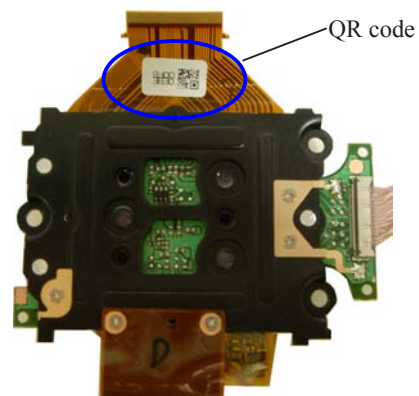

【How to confirm】

* Perform "QrReader (J65096)". Play back the image of the shot QR code, and confirm that reading of the QR code on the playback screen can be read out with two-dimensional barcode reader.

- Gr/Gb difference compensation adjustment (G filter)
 - Attach the tool lens (Aperture F5.6) and SP2 (G filter) to the camera.
 - Get the camera closest to the center of the illuminated surface of the color viewer.
 - The adjustment starts. When it is completed, "OK" is displayed.
 - The software automatically goes on to the next adjustment item.

- (2) Dark current adjustment
 - Attach the body cap and eyepiece cap.
 - The adjustment starts. When it is completed, "OK" is displayed.

- (3) Sensitivity adjustment
 - Click "2. SENSITIVITY ADJUSTMENT" of the main menu on screen.
 - Attach the tool lens (Aperture F8) and ND filter (ND 8× 2) to the camera.
 - Get the camera closest to the center of the illuminated surface of the color viewer.
 - The adjustment starts. When it is completed, "OK" is displayed.
 - The software automatically goes on to the next adjustment item.

- (4) Shading adjustment
 - Click "3. SHADING ADJUSTMENT" on the menu.
 - Attach the tool lens (Aperture F5.6) and ND filter (ND 4× 2) to the camera.
 - Get the camera closest to the center of the illuminated surface of the color viewer.
 - The adjustment starts. When it is completed, "OK" is displayed.
 - The software automatically goes on to the next adjustment.

- (5) Gr/Gb compensation adjustment (R/B filter) - Line crawl adjustment
 - Click "4. Gr/Gb COMPENSATION ADJ (R/B FILTER)" on the menu.
 - Attach the tool lens (Aperture F5.6) and SP3 (R filter) to the camera.
 - Get the camera closest to the center of the illuminated surface of the color viewer.
 - The adjustment starts. When it is completed, the next instructions are displayed.
 - Attach the tool lens (Aperture F5.6) and SP1 (B filter) to the camera.
 - Get the camera closest to the center of the illuminated surface of the color viewer.
 - The adjustment starts. When it is completed, "OK" is displayed.
 - The software automatically goes on to the next adjustment.

- (6) Sensitivity ratio adjustment
 - Click "5. SENSITIVITY RATIO ADJUSTMENT" of the main menu on screen.
 - Attach the tool lens (Aperture F5.6) to the camera (without filter).
 - Get the camera closest to the center of the illuminated surface of the shutter tester.
 - The adjustment starts. When it is completed, "OK" is displayed.
 - Get the camera closest to the center of the illuminated surface of the color viewer.
 - The adjustment starts. When it is completed, "OK" is displayed.

(7) Image shutter adjustment

- Click "6. IMAGE SHUTTER INS. & ADJ." of the main menu on screen.
- Attach the tool lens (Aperture F5.6) to the camera.
- Get the camera closest to the center of the illuminated surface of the shutter tester.
- Make inspection and adjustment with the luminance LV9 and LV15.
- Confirm that the inspection is within standard.

8-2. Pixel defect compensation - black point

- Set the color viewer luminance to LV13 equiv.
- Provide the power for the camera via AC adapter.
- Reset "Custom setting".
- Set "PTP" mode by Setup menu.
- Set the focus mode to "M", exposure mode to "M", and the exposure compensation to "0" of the camera.
- Connect the camera and PC via USB cable.
- Click "BLACK POINT" of "PIXEL DEFECT COMPENSATION" of the menu.
- Attach the tool lens (Aperture F5.6) to the camera (without filter).
- Get the camera closest to the center of the illuminated surface of the color viewer.
- When the adjustment starts, pixel defects are detected, displaying the number of pixels and addresses.
- After confirming the above, click "X" button.
- When it is completed, "OK" is displayed.
- The software automatically goes on to the next "WHITE POINT" of "PIXEL DEFECT COMPENSATION".
(After the black point compensation, be sure to perform the white point compensation, too.)

Note: In some cases, NG occurs due to dusts on the OPLF.

Be sure to clean the OPLF surface before adjustments.

8-3. Pixel defect compensation - white point

- Check the environmental temperature (approx. 20-25°C.).
- Provide the power for the camera via AC adapter.
- Reset "Custom setting".
- Set "PTP" mode by Setup menu.
- Set the focus mode to "M", exposure mode to "M", and the exposure compensation to "0" of the camera.
- Connect the camera and PC via USB cable.
- Click "WHITE POINT" of "PIXEL DEFECT COMPENSATION" of the menu.
- Cap the camera with the body cap or lens cap to shield light from the mount.
- When the adjustment starts, pixel defects are detected, displaying the number of pixels and addresses.
- After confirming the above, click "X" button.
- When it is completed, "OK" is displayed.

8-4. TFT adjustment

- Provide the power for the camera via AC adapter.
- Connect the camera and PC via USB cable.
- Turn the camera ON.

Hue adjustment

- Usually the default value is used, and the adjustment is not necessary.
- If there is some problem with hue by visual check, operate the slider to make the adjustment.
- Remove the USB cable from the camera. Do NOT turn the power switch to OFF, but remove the AC adapter.

Luminance adjustment

- Usually the default value is used, and the adjustment is not necessary.
- If there is some problem with luminance by visual check, operate the slider to make the adjustment.
- Remove the USB cable from the camera. Do NOT turn the power switch to OFF, but remove the AC adapter.

8-5. Obtain reference values

- Set the color viewer luminance to LV13 equiv.
 - Provide the power for the camera via AC adapter.
 - Reset "Custom setting".
 - Set "PTP" mode by Setup menu.
 - Set the focus mode to "M", exposure mode to "M", and the exposure compensation to "0" of the camera.
 - Connect the camera and PC via USB cable.
 - Select "OBTAIN REFERENCE VALUE." of the menu on screen.
 - Click "Start".
 - The calculation of the sensitivity reference value starts. The message to set conditions is displayed.
 - Attach the tool lens (Aperture F8) and ND filter (ND 8×2) to the camera.
 - Get the camera closest to the center of the illuminated surface of the color viewer.
 - The obtaining starts. When it is completed, the software goes on to the sensitivity ratio reference value.
 - Attach the tool lens (Aperture F5.6). (Remove ND filter).
 - Get the camera closest to the center of the illuminated surface of the shutter tester of LV9.
 - Get the camera closest to the center of the illuminated surface of the color viewer of LV13 equiv.
 - The confirmation of acquired value starts. When it is completed, the sensitivity and sensitivity reference values are stored in the standard setting file (D300BSD.DAT).
 - After this procedure, when the shooting image adjustment is made, the sensitivity and sensitivity ratio that have been calculated this time are used.
- ※ Calculate the sensitivity and sensitivity ratio reference values once in about every 3 months, and when the fluorescent of the color viewer is replaced.

8-6. Version No./Serial No.

- Provide the power for the camera via AC adapter.
- Set "PTP" mode by Setup menu.
- Connect the camera and PC via USB cable.
- Click "RISC VERSION" of the menu on screen.
- RISC version number/Serial number will be displayed.
- * Cancelling "Read only" enables inputting the serial number.
- ※ Whenever the license sheet is replaced, be sure to input the new serial number.

8-7. Procedure for upgrading RISC firmware

- After preparing the CF card, copy the latest version (XXXX. BIN) into the root directory.
- Insert the CF card, and select "FIRMWARE VERSION" from the SETUP menu.
- Follow the instructions on screen for version updating. It takes approx. 3-4 minutes.
- Check the version of firmware by "RISC VERSION" of the image adjustment software.

Note:

In case incorrect files are included in the CF card, the details for updating are not displayed even after selecting "FIRMWARE VERSION" from the SETUP menu.





11. Setting of two-dimensional barcode reader

- Insert the two-dimensional barcode reader into the USB terminal.
- Read the bar codes shown below.



Reference:

To avoid reading errors, use a masking sheet of the left picture, which is supplied with a two dimensional barcode reader.

 ~ D E F A L T .	全デフォルト
 ~ T E R M I D .	ターミナル ID 設定開始
 ~ K 1 K	USB バーチャル COM インターフェイス
 ~ K 3 K	
 ~ K 0 K	
 ~ M N U S A V .	ターミナル ID 設定終了

- After the reading, the dialog box that shows the new hardware is recognized will be displayed.
- Click "Next".

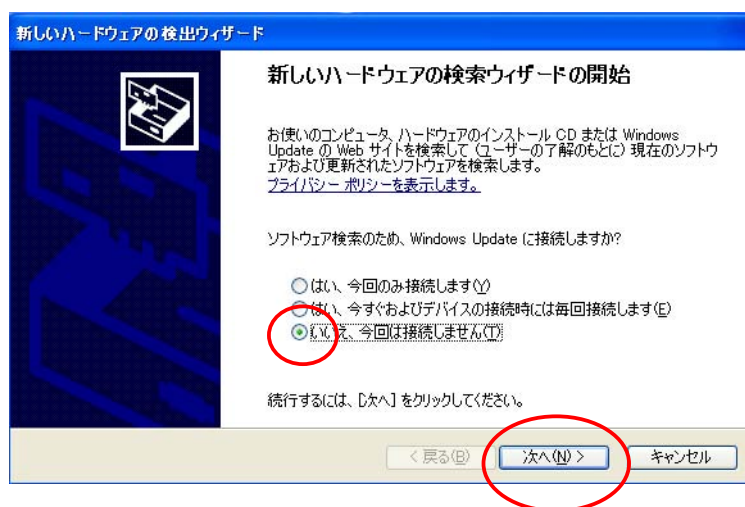

- Insert the CD-ROM which is supplied with a two-dimensional barcode reader into the PC.

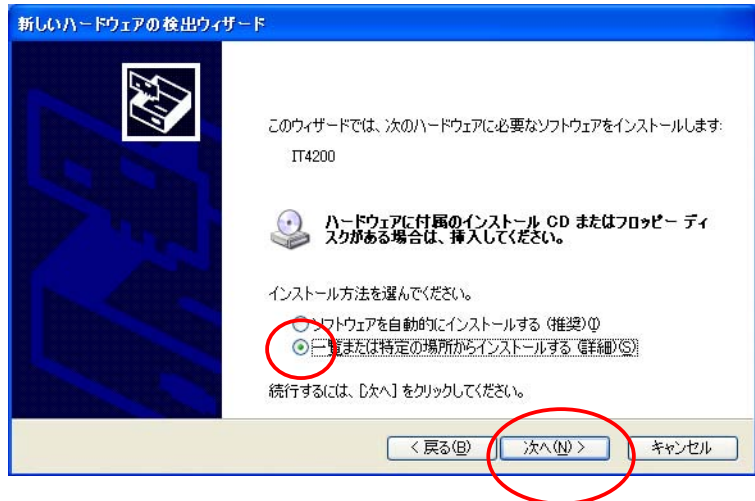

- Click "Reference" and select "IT4200" in the CD-ROM folder.

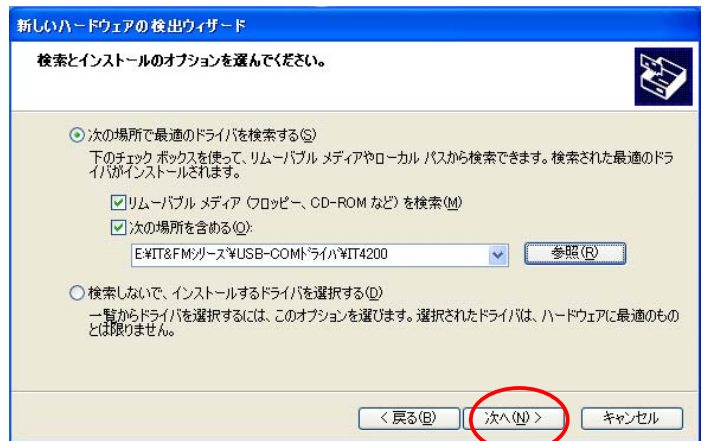
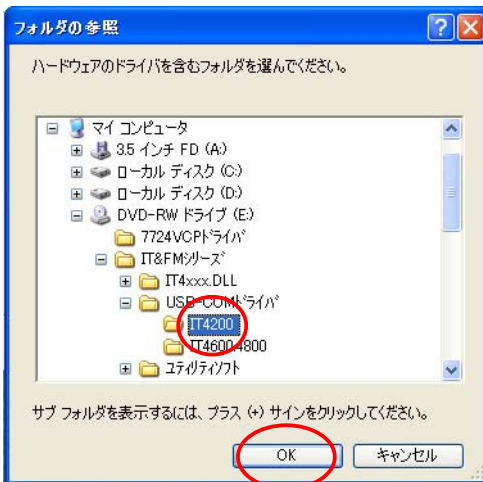

- Click "Finish" and take out the CD-ROM from the PC.

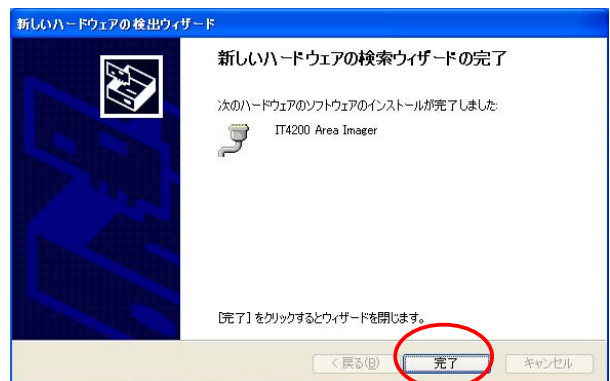
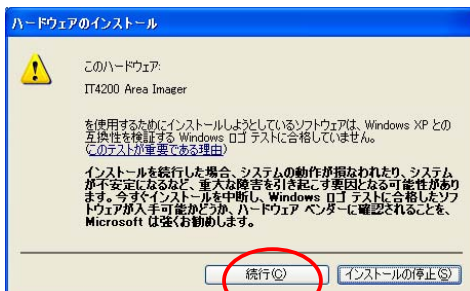

- Open "Device Manager" and confirm the port setting.
Click the right mouse button on "My Computer". Then, select the items in the following order:
[Properties] → [Hardware] → [Device Manager].

Note:The port setting differs depending on the PC environment.

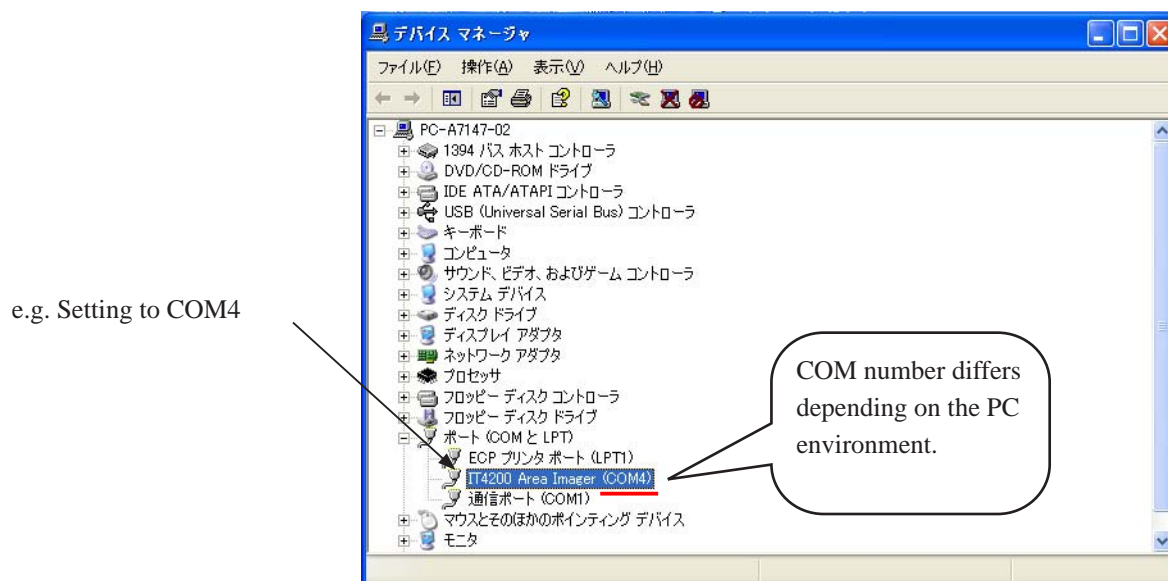

- Set the port that was confirmed by "Device Manager".

Parallax inspection and adjustment

Caution : When "Separate Prism box from Front body" is performed, be sure to make the adjustment.

Procedure

- ① Insert the battery into the camera, and set the exposure mode to "P".
- ② Turn the power SW to OFF, and remove the battery. (By this procedure, the camera memorizes the latest set mode in the camera.)
- ③ Remove the four FPCs and two wires of the top cover, then detach the top cover from the camera.

Note: If the FPC of the top cover is removed with the battery being inserted, the DC/DC, etc. may be burned out.

- ④ Attach the parallax/SI chart (J63103) on the wall, etc.
- ⑤ Put the CF card and battery into the camera, and mount the lens AF 50/1.4.
- ⑥ Position the camera correctly 70 cm-distance from the parallax-inspection chart by using the tripod, etc. (ref. Fig. 1.) (Set the optical axis of lens to come in the center of the chart.)

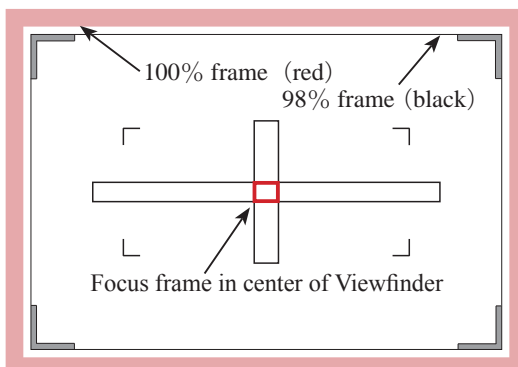

Parallax / SI chart (J63103)

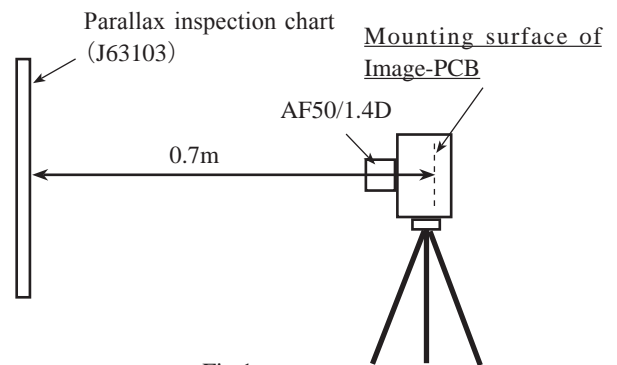

Fig.1

- ⑦ Take a shot of the chart with MC-30, and display it on the TFT monitor to fine adjust the camera position so that all four sides of the 98 % chart frame can appear on the monitor.
- ⑧ Look through the viewfinder, then in order to meet the standard, all four sides between the 100 % frame and 98 % frame must be seen.

In case it is out of standard, remove the battery and make the following adjustment.

- ⑨ Loosen the four screws (#1612) of the prism box, then move the prism box so that the four sides in the viewing field of the finder come in between the 100% chart frame and 98% chart frame.
- ⑩ Confirm that the focus frame in the center of the viewfinder is within the (cross shaped) metering-distance frame in the center of the parallax/SI chart.
- ⑪ Tighten the loosened four screws (#1612). (After tightening them, check the angle of view of the viewfinder.)
- ⑫ Insert the battery into the camera, and take a shot of the chart again with MC-30. Confirm that the camera does not move. If it moves, make the adjustment from the procedure of ⑦ of Repair Manual.

AF XY adjustment

X adjustment corrects the position of the AF FPC unit in X-axis direction by the screw, and also makes the electrical fine-adjustment in XY-axis directions.

Caution: Whenever the AF FPC unit is disassembled or replaced, be sure to make the X/Y adjustment.

Procedure

Make the adjustment, based on the AF accuracy adjustment of the adjustment software (J18433).

- "X position adjustment" positions the mounting base of the AF FPC unit in the horizontal direction against the body. Loosen the three fixation screws of the mounting base as shown in "Fig.1". Rotate the eccentric pin (with Hexagonal key) so that the results are within the standard of the adjustment software. Then tighten the three fixation screws.

Fig.1

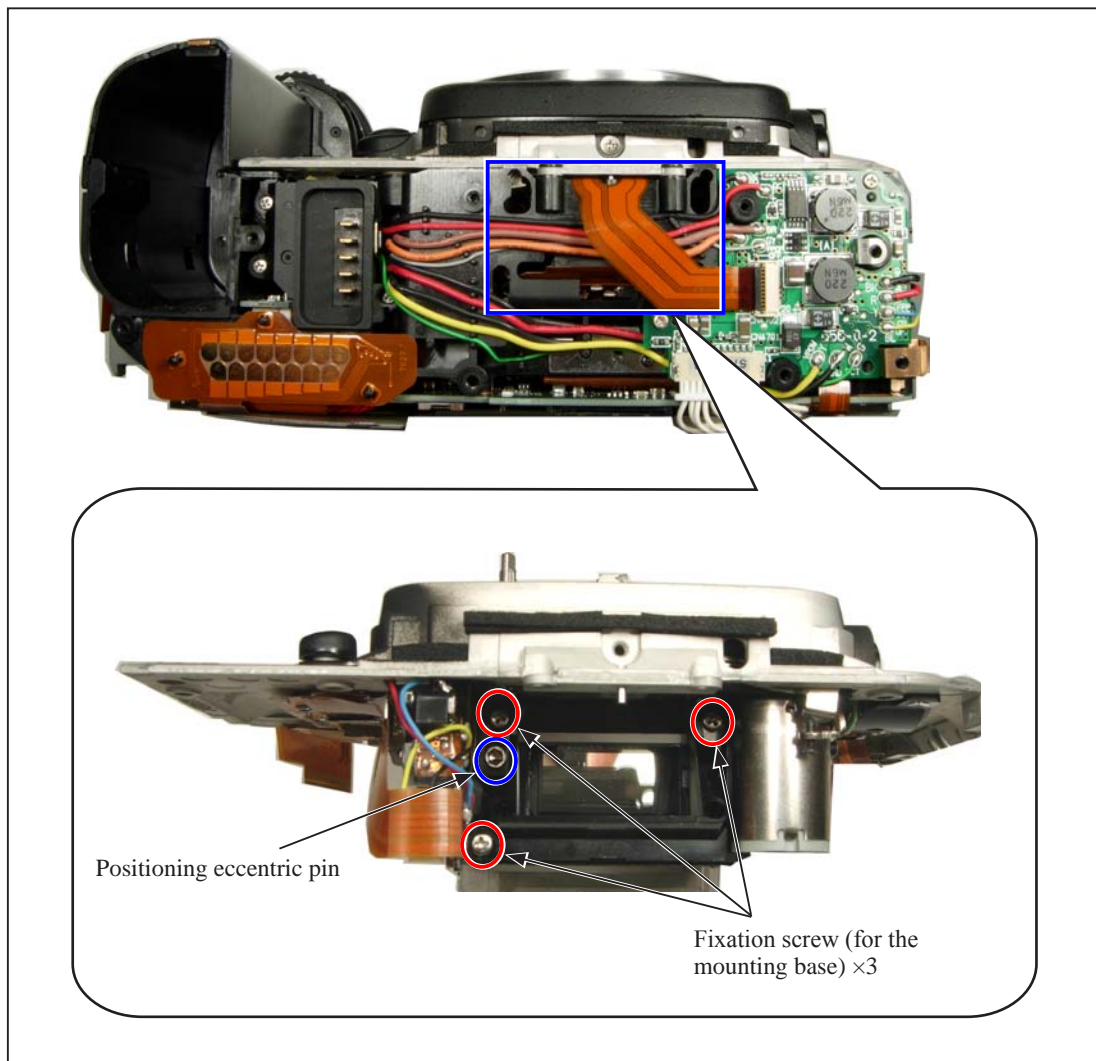

< Measurement of Consumption current value >

When this camera is used for measuring the consumption current value, set the MB-D200 and wire as follows.

* Modify "MS-D10" and connect wires.

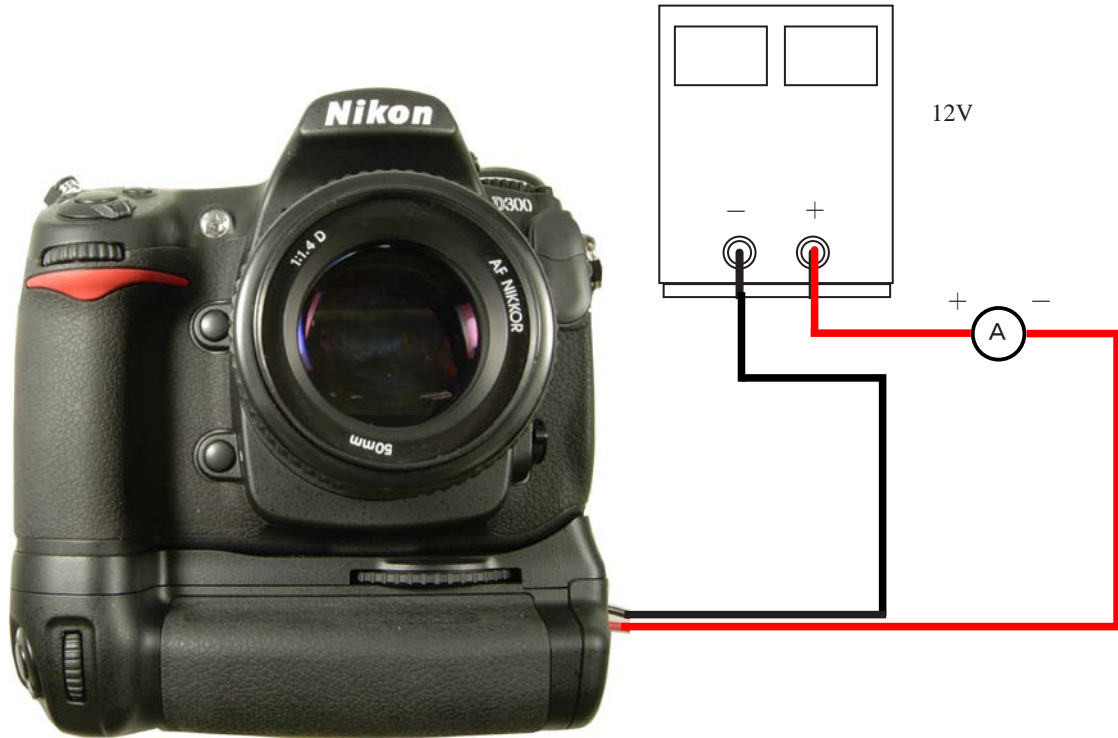

Test item	Standard	Test condition
Main SW • OFF All operational buttons are NOT pushed.	150 μ A or less	AF50/1.4D, EV12
Main SW • ON (Half-release timer OFF)	150 μ A or less	
Main SW • ON (Half-release timer ON)	220 m A or less	
Main SW • ON (Illumination ON)	250 m A or less	
Main SW • ON (TFT ON)	300 m A or less	
Live view ON	770 m A or less	

Caution:

The standard values of the consumption current values are those measured when the backup battery is fully charged.

Penta prism and SI dust cleaning in LCD

《Cleaning without removing Screen box》

- Take out two screws (#1504), and remove the mirror receiving part.

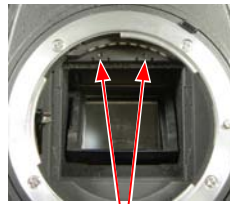

#1504×2

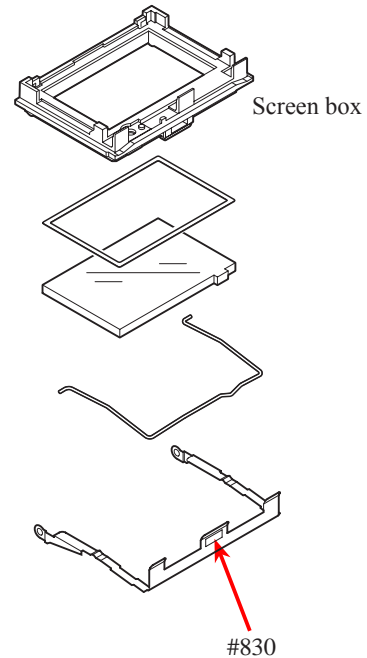

- Release the claw (indicated by the arrow) of the screen-box retaining plate (#830), and lower [#830].

- Get the screen box section straight down to the position as shown in the picture.

* Do NOT get it down forcibly because the FPCs are connected.

- Cleaning is possible with a blower in the red circled area.

- After the cleaning, get the screen box section straight up and assemble it. Then, fixate it with the screen-box retainer plate (#830).

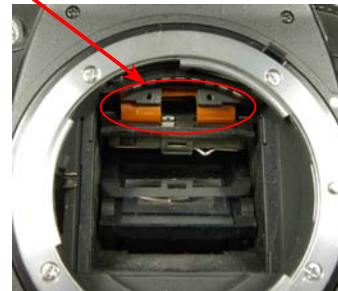

《Cleaning by removing Screen box》

- Remove the mount and front cover. Disconnect the SI-FPC from the connector and remove the screen box section. Perform cleaning.

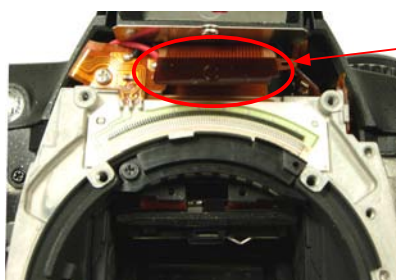

SI-FPC



Screen box section

Caution: Whenever the above cleaning is performed, make the inspection of focusing in the viewfinder after assembly.

D300 実体配線図 D300 WIRING

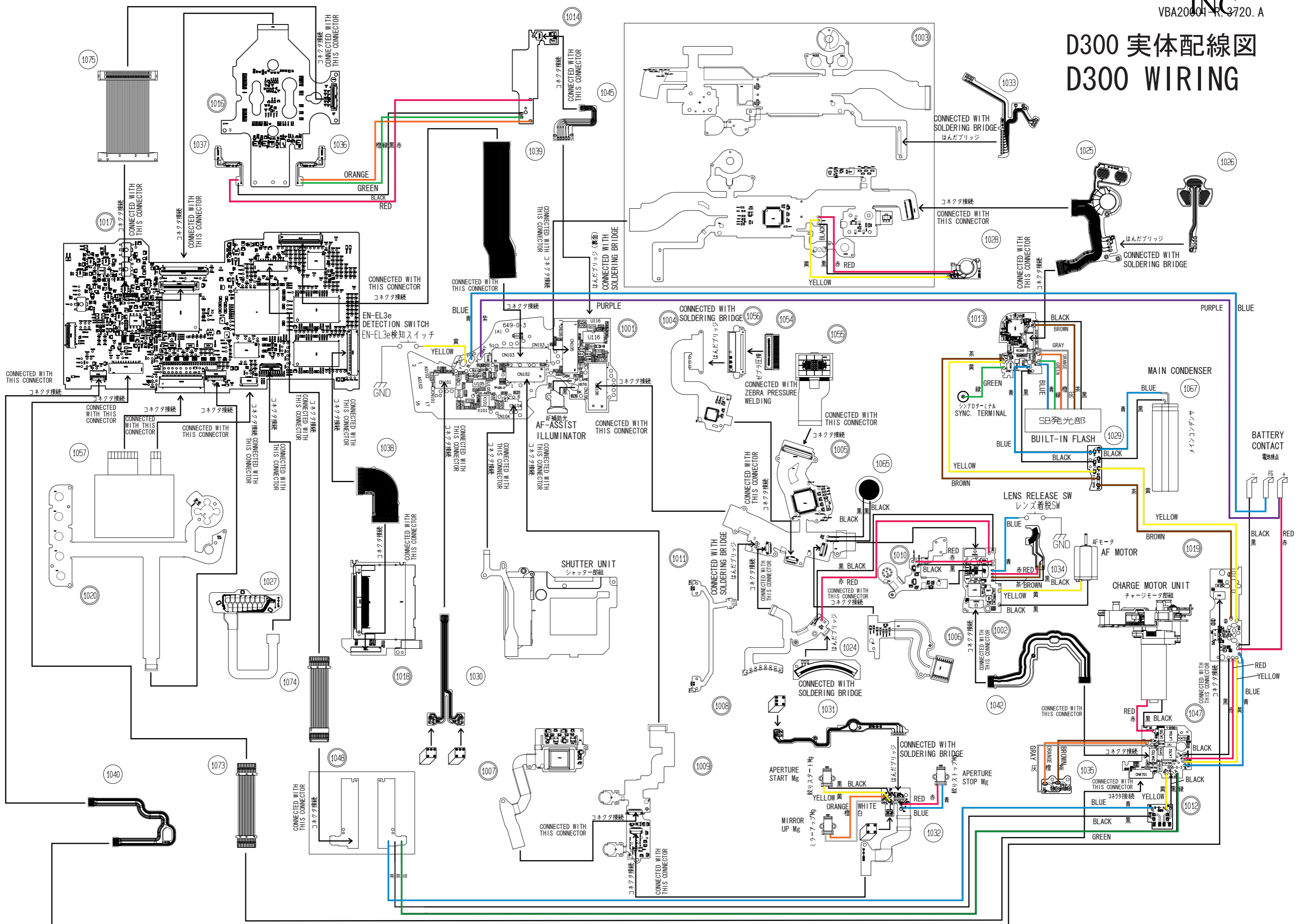

VBA20001-R. 3720. A

メイン基板 (表)

MAIN BASE PLATE (Surf face)

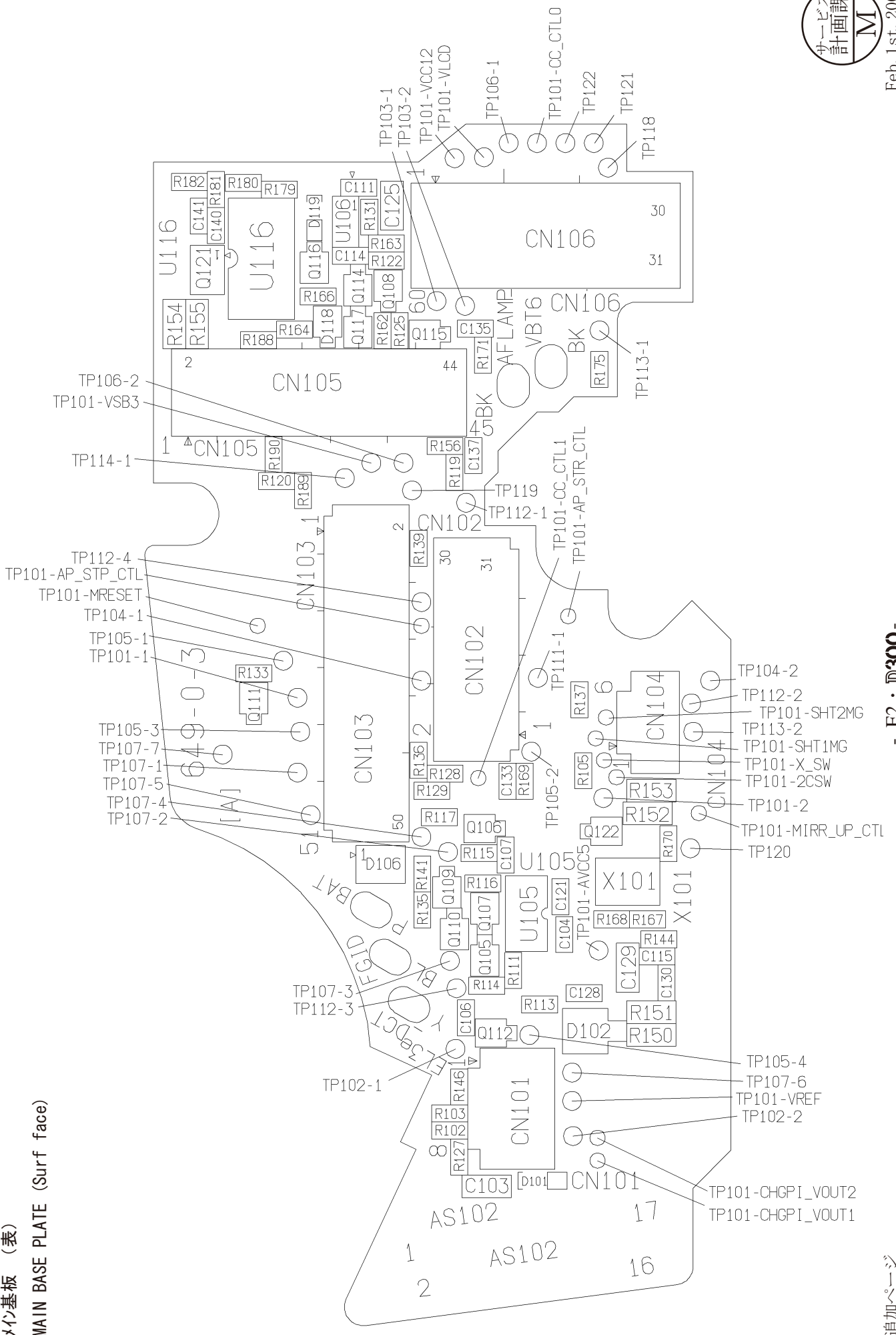

メイン基板 (裏)

MAIN BASE PLATE (Reverse face)

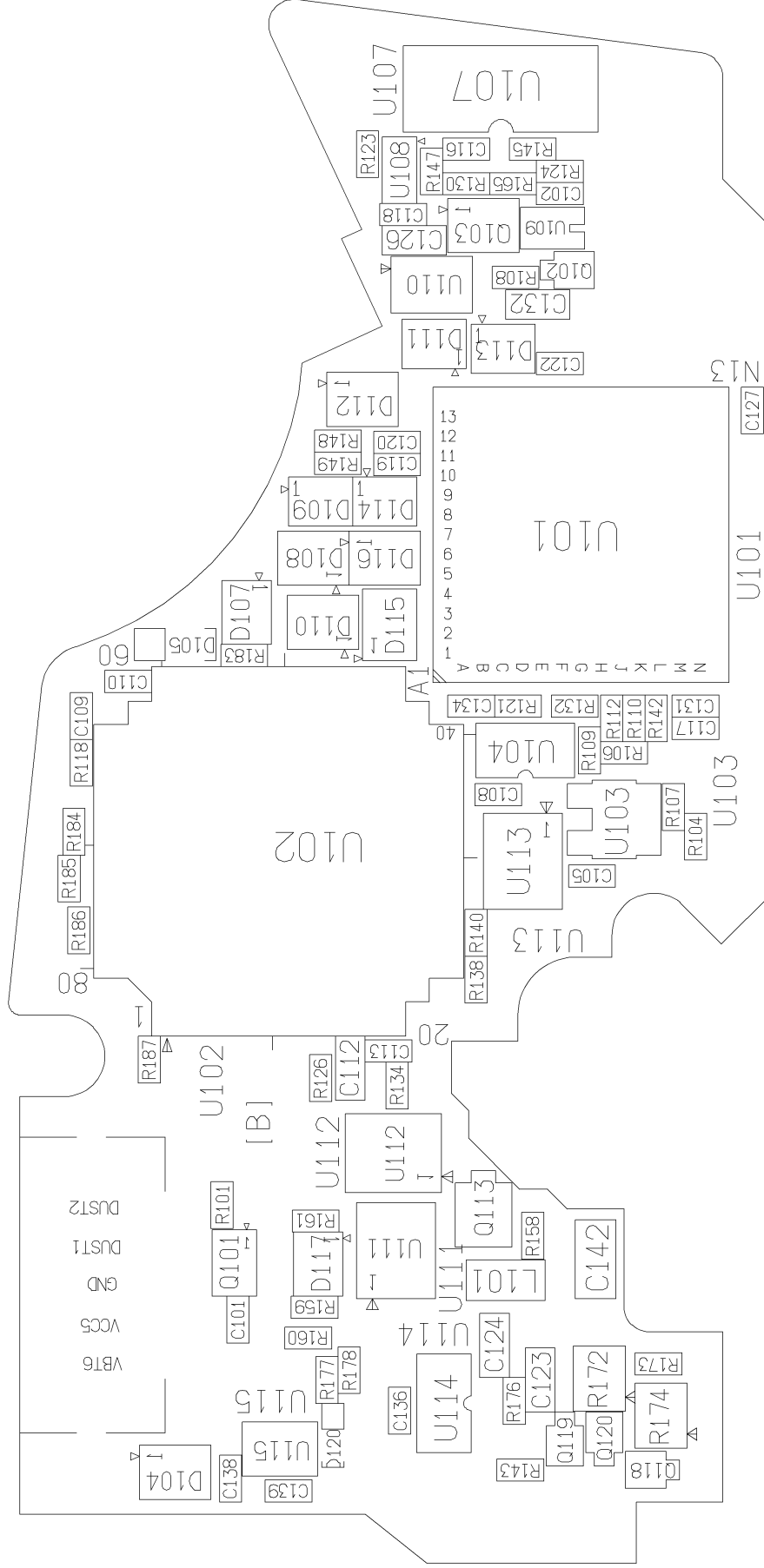



VBA20001-R. 3720. A

DG 基板 (表)

DG PCB (Surf face)

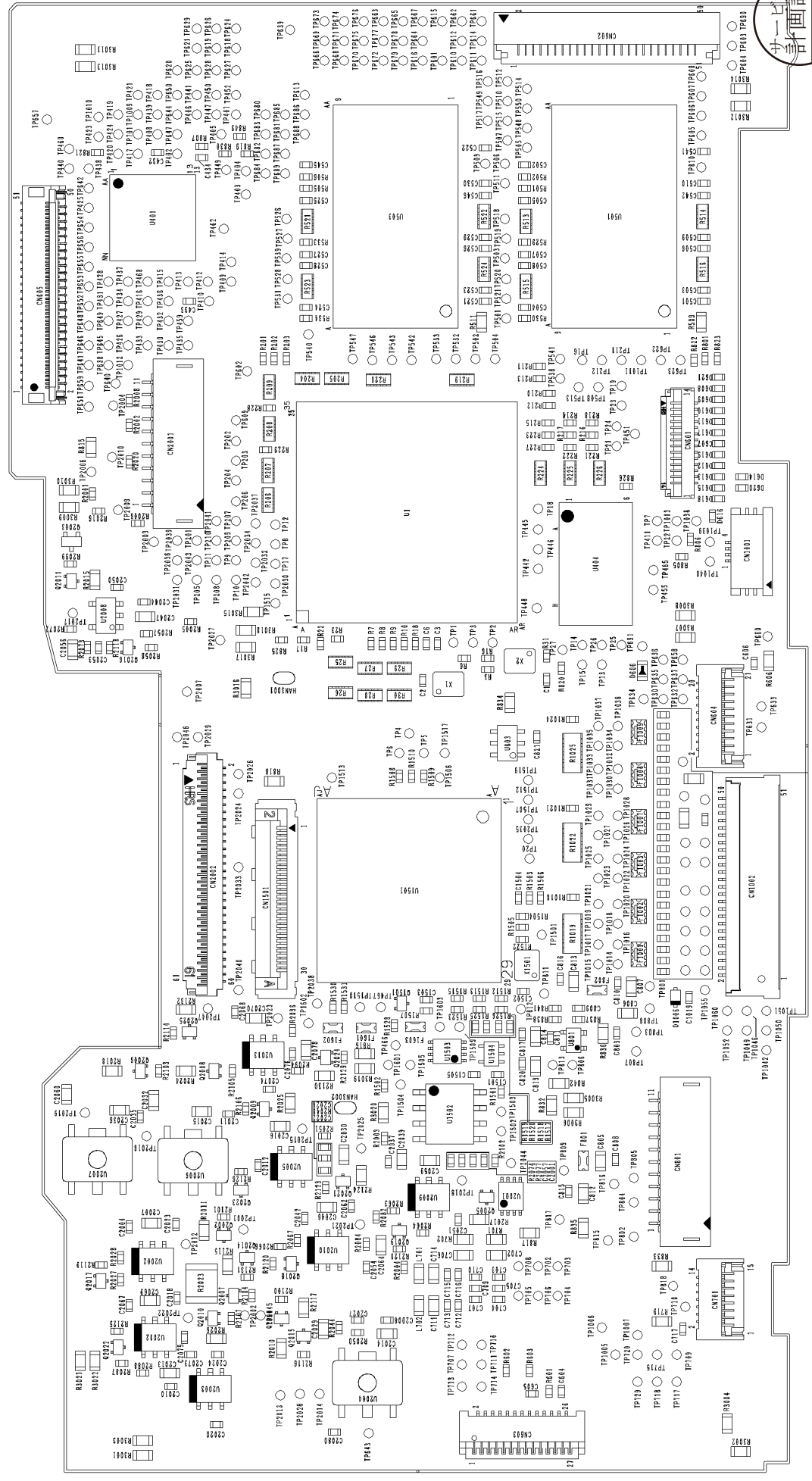

VBA20001-R. 3720. A

DG 基板 (裏)

DG PCB (Reverse face)

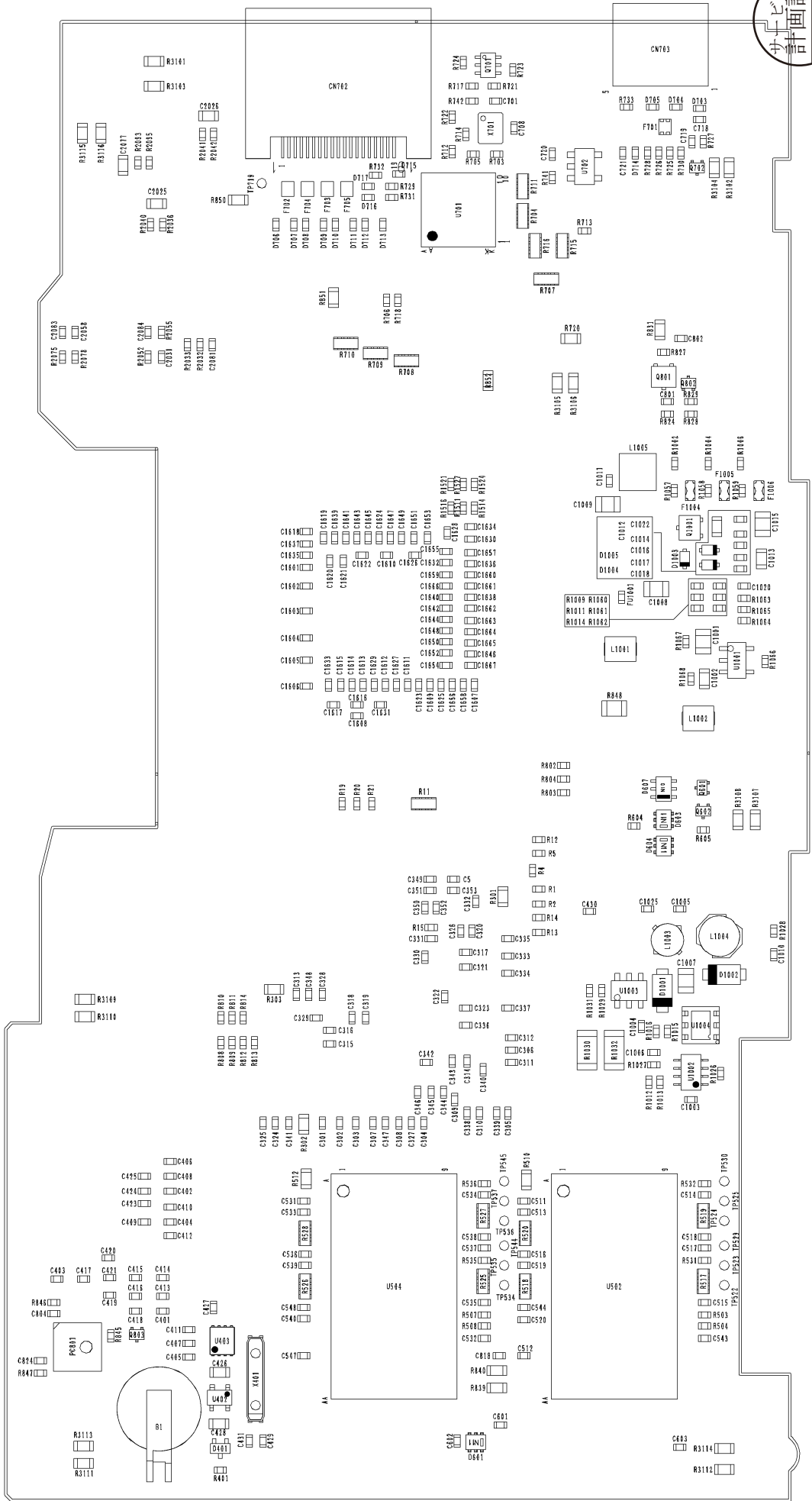

VBA20001-R. 3720. A

PD 基板 (裏)

PD BASE PLATE (Reverse face)

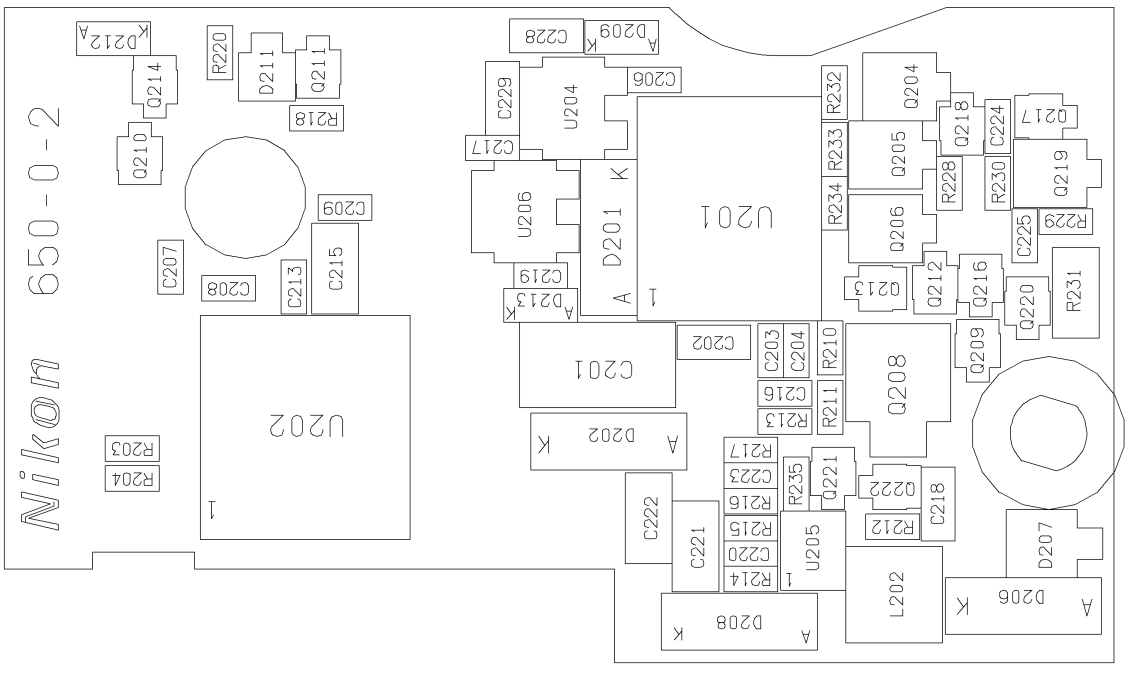

PD 基板 (表)

PD BASE PLATE (Surf face)

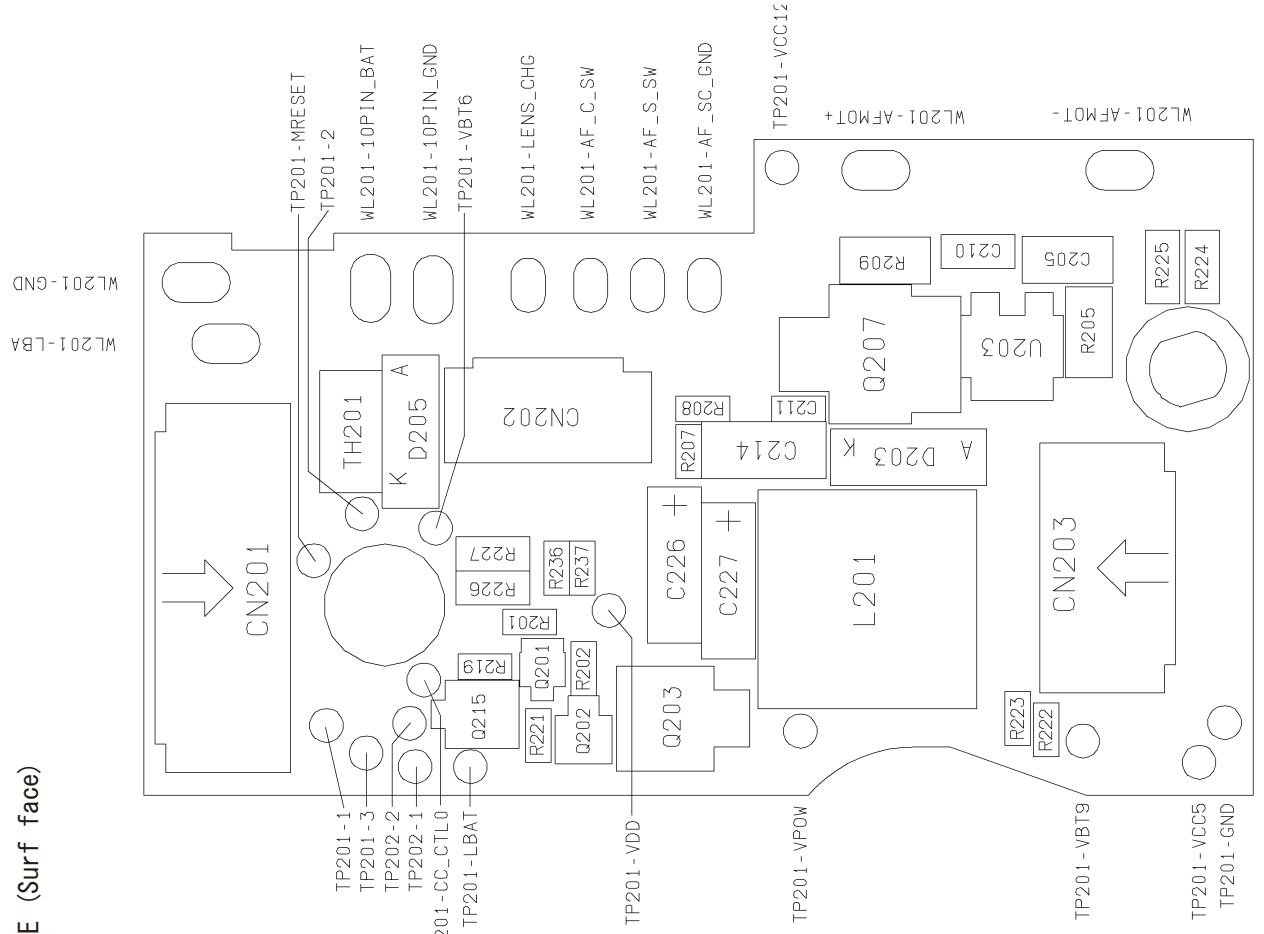



SB 基板 (裏)

SB BASE PLATE (Reverse face)

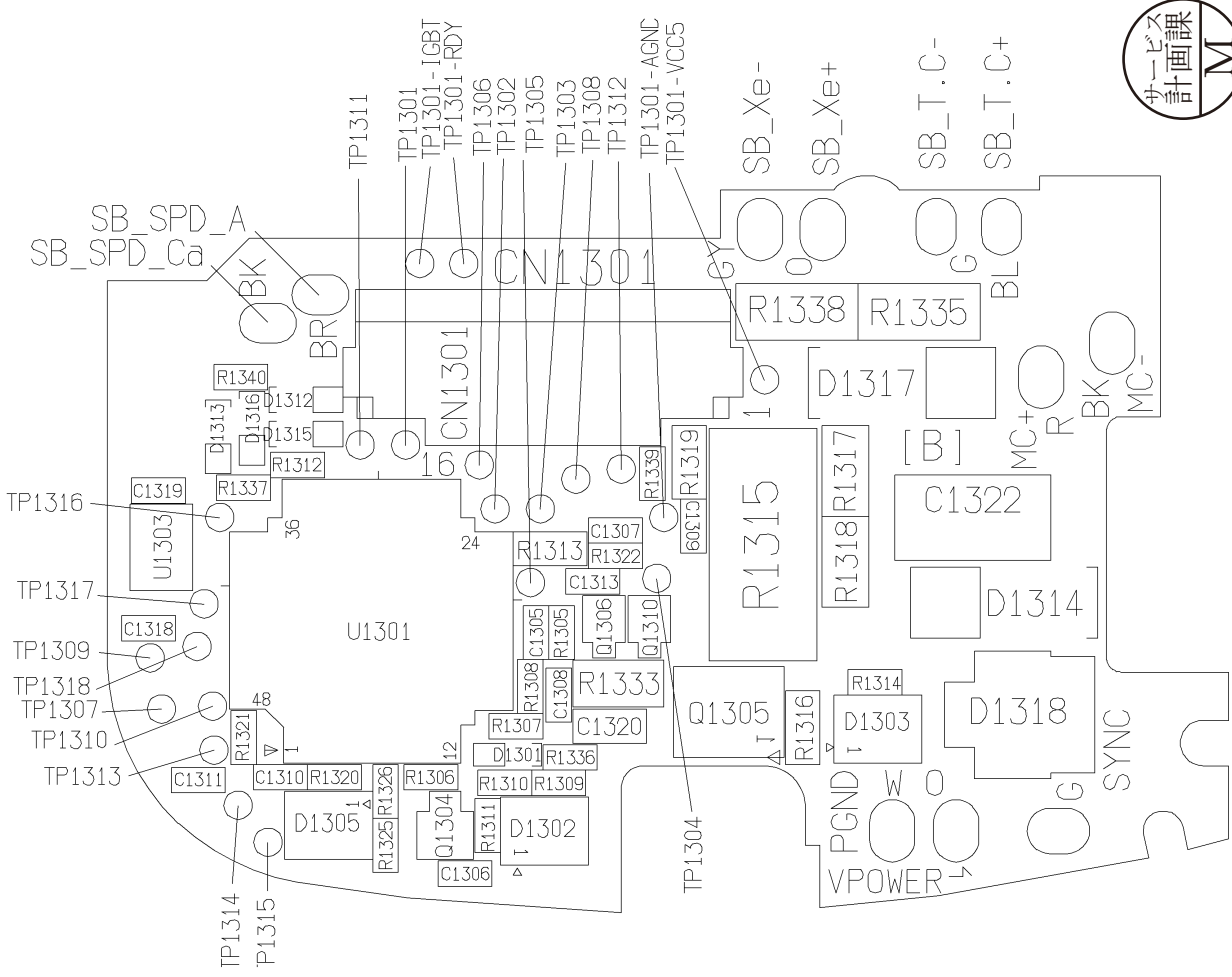

SB 基板 (表)

SB BASE PLATE (Surf face)

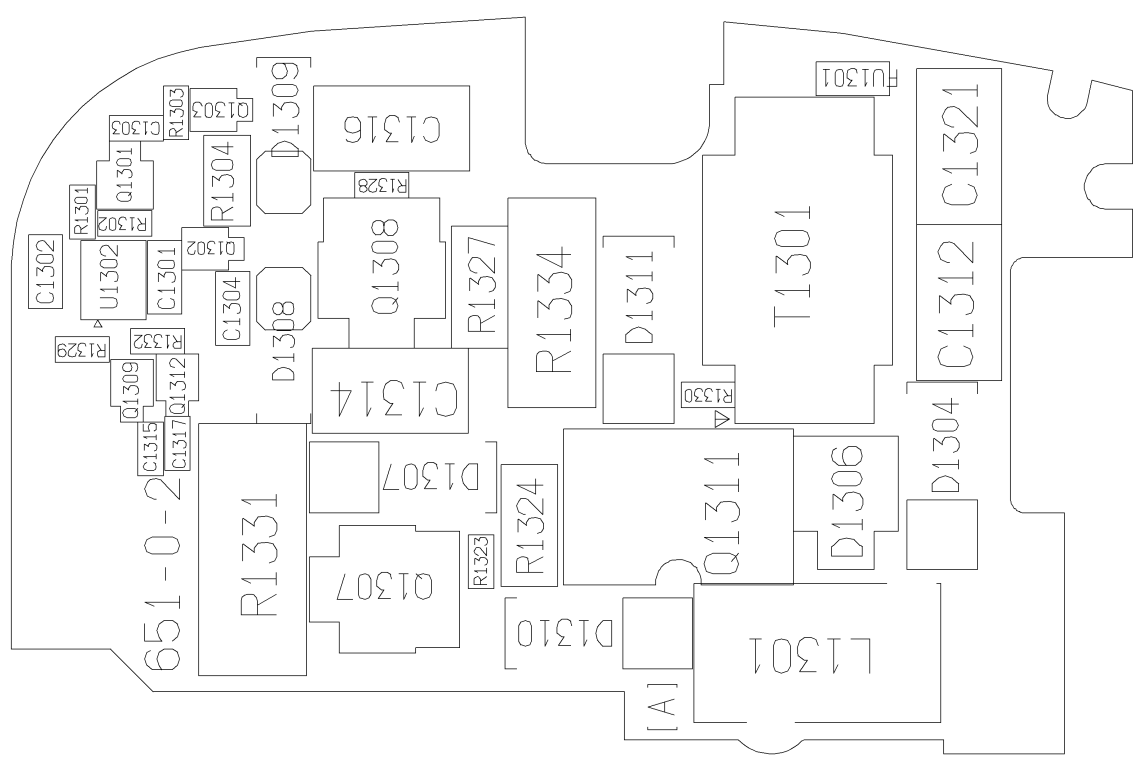

VBA20001-R. 3720. A

CF 基板 (裏)
CF BASE PLATE (Reverse face)

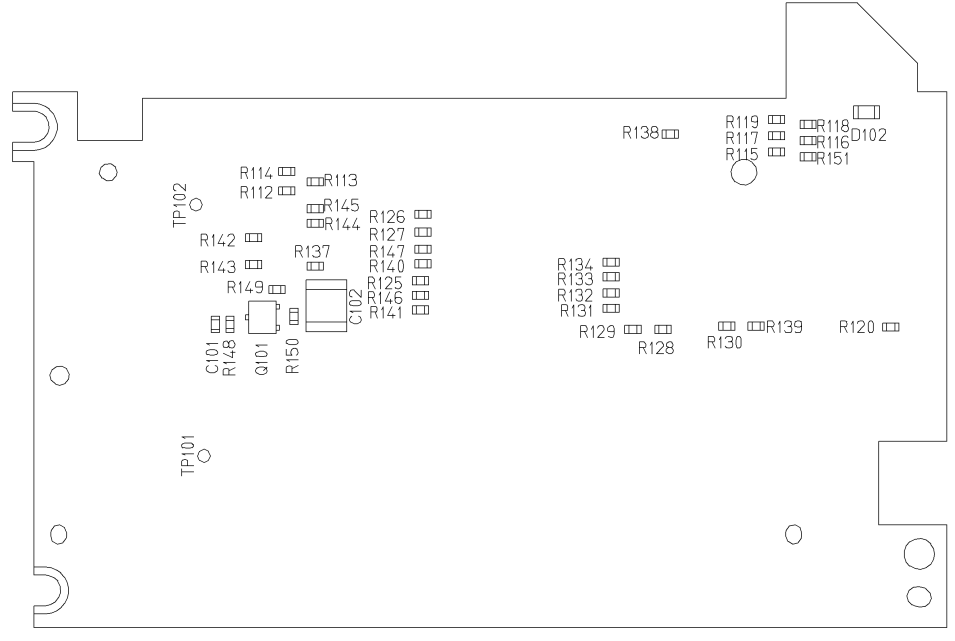

CF 基板 (表)
CF BASE PLATE (Surf face)

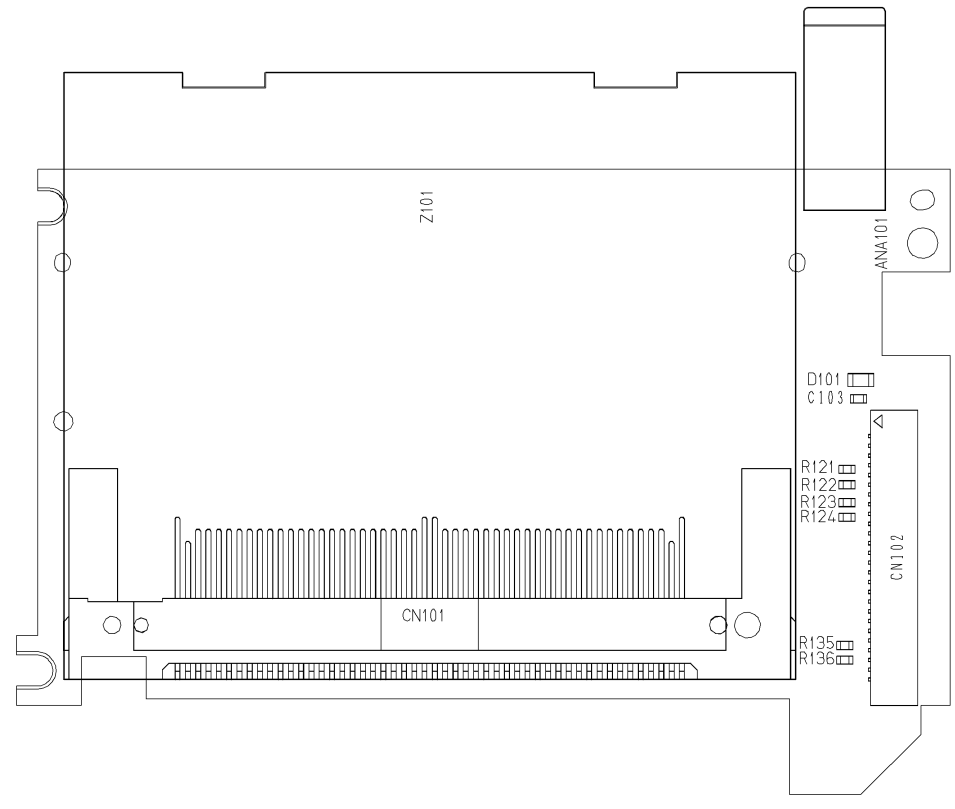

VBA20001-R. 3720. A

IF 基板 (裏)
IF BASE PLATE (Reverse face)

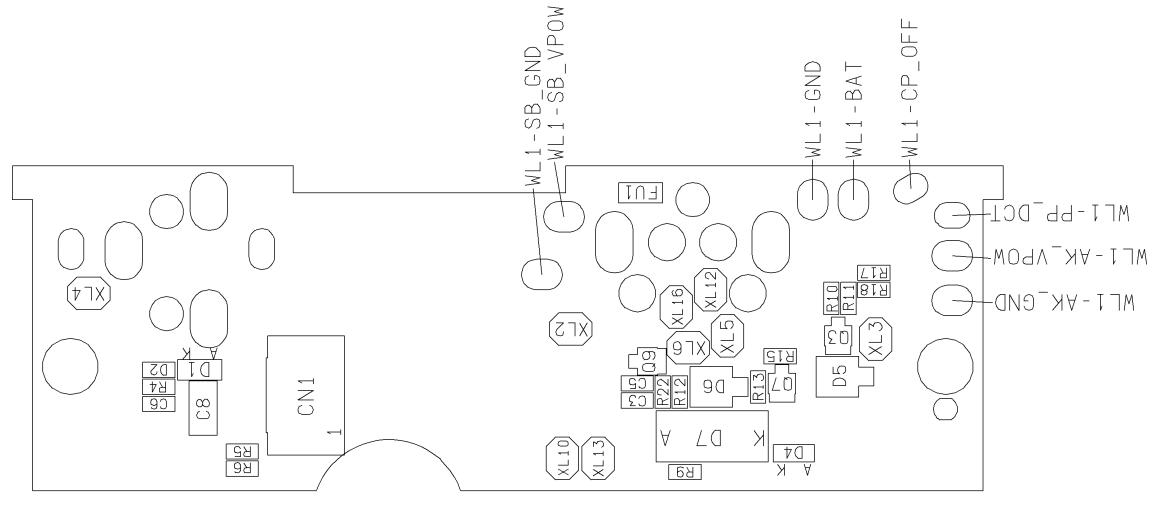

IF 基板 (表)
IF BASE PLATE (Surf face)

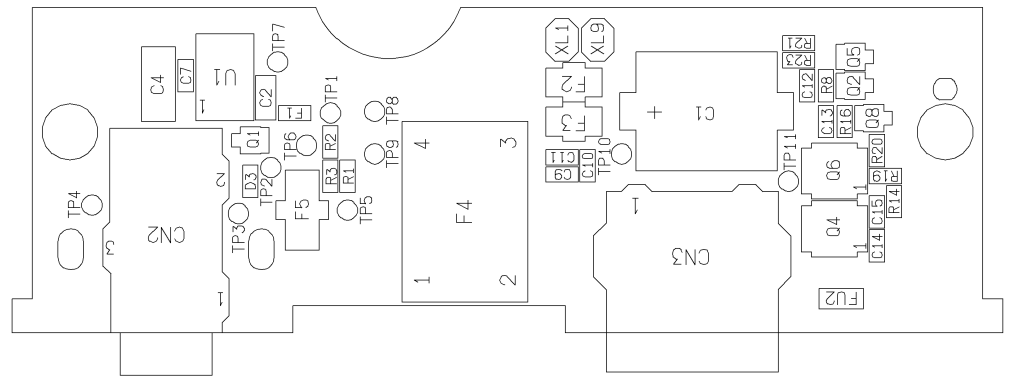

VBA20001-R. 3720. A

DC/DC AK 基板 (裏)
DC/DC AK BASE PLATE (Reverse face)

DC/DC AK 基板 (表)
DC/DC AK BASE PLATE (Surf face)

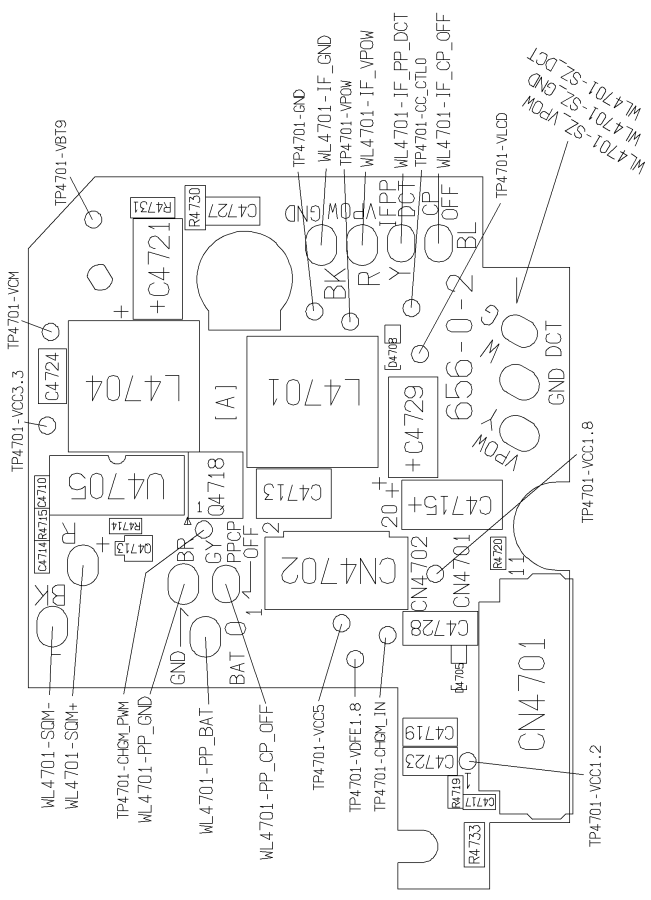
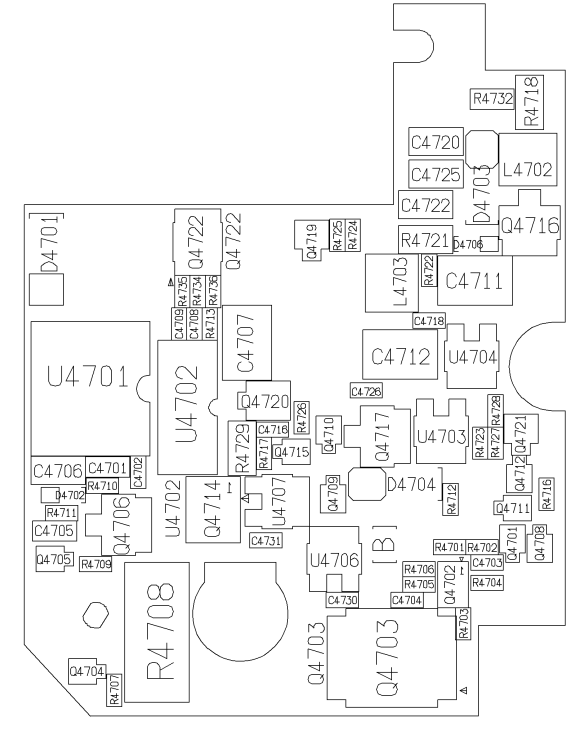

VBA20001-R. 3720. A

DC/DC SZ 基板 (裏)

DC/DC SZ BASE

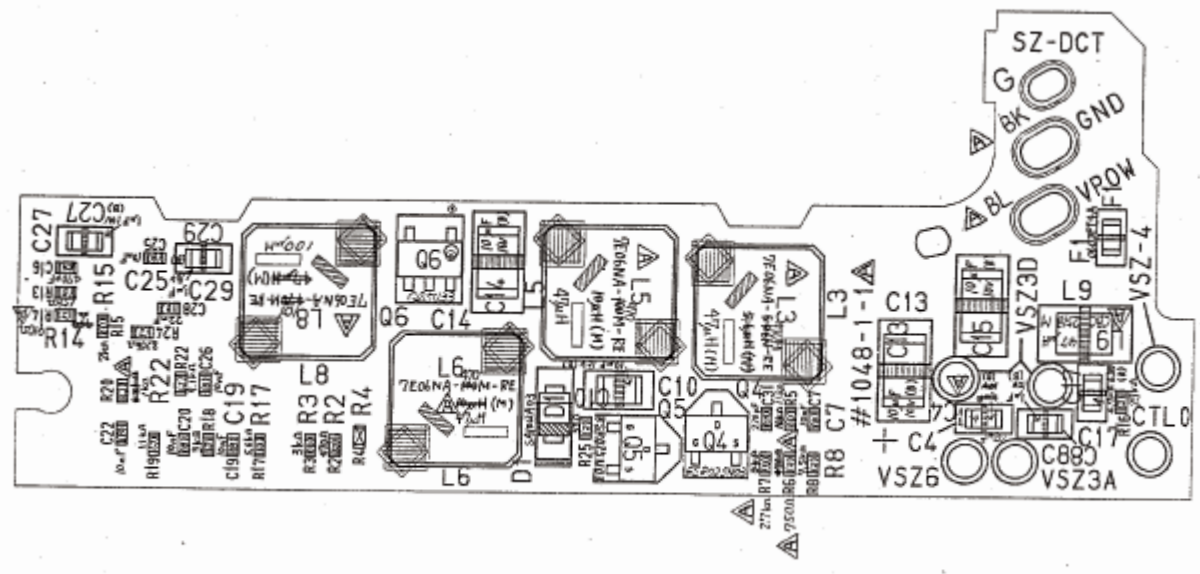

DC/DC SZ 基板 (表)

DC/DC SZ BASE PLATE (Surf. face)

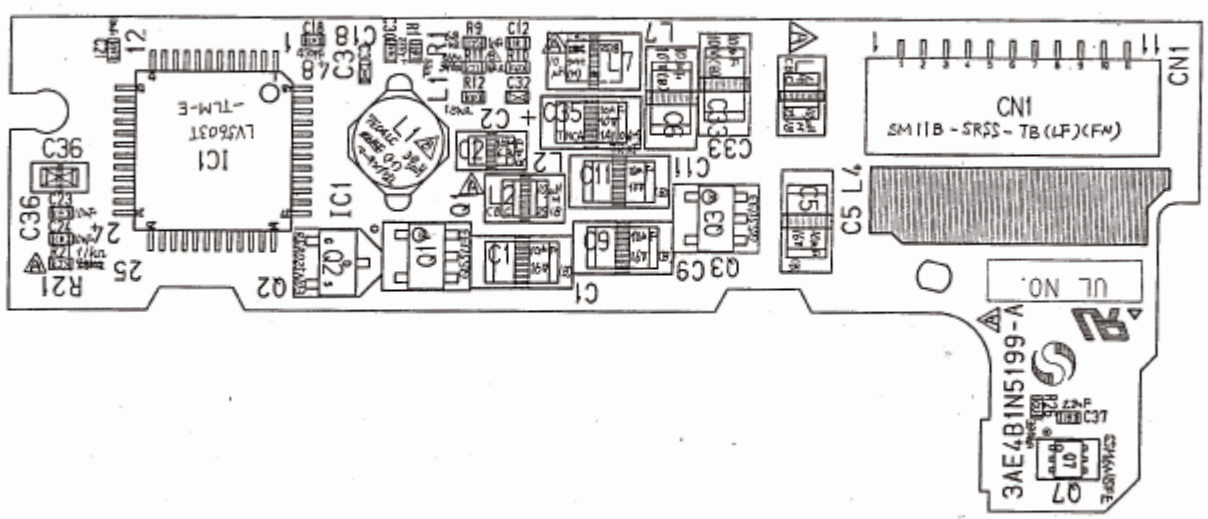

VBA20001-R. 3720. A

DR 基板 (表)

DR BASE PLATE (Surf face)

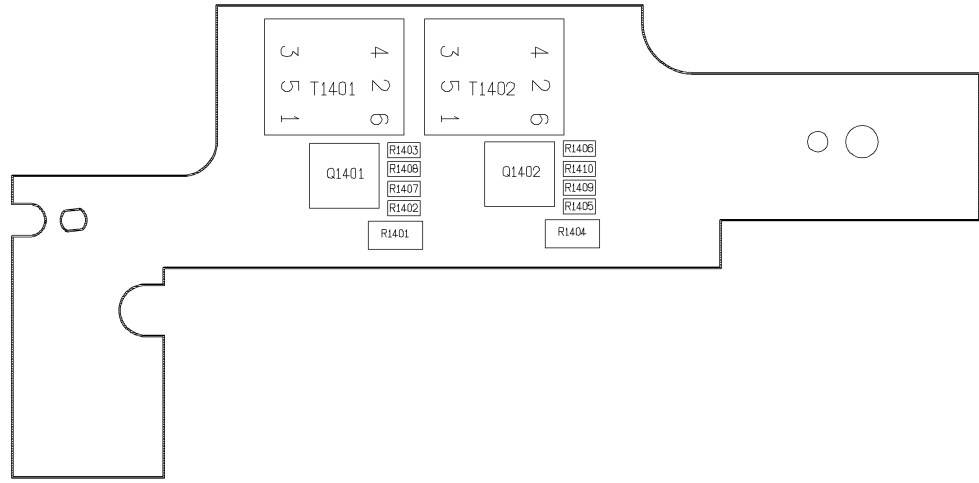

DR 基板 (裏)

DR BASE PLATE (Reverse face)

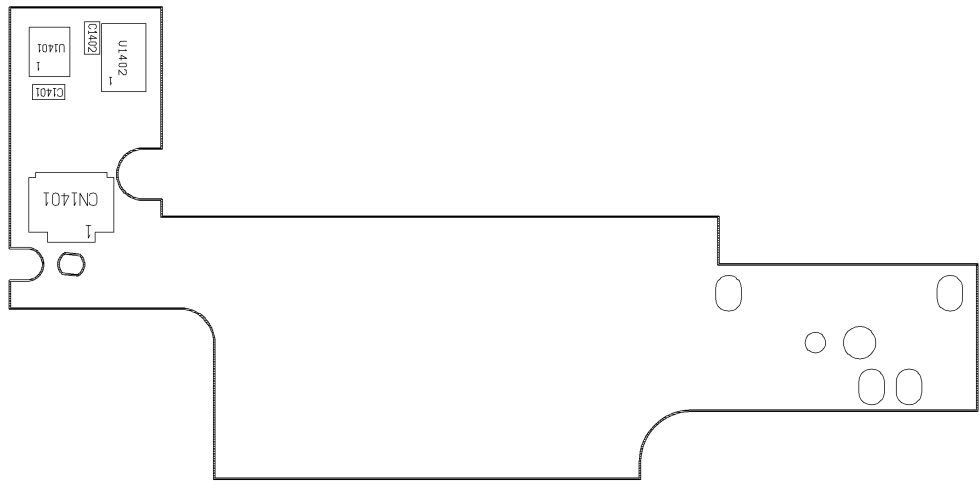

フィルタ基板 (裏)

FILTEL BOARD (Reverse face)

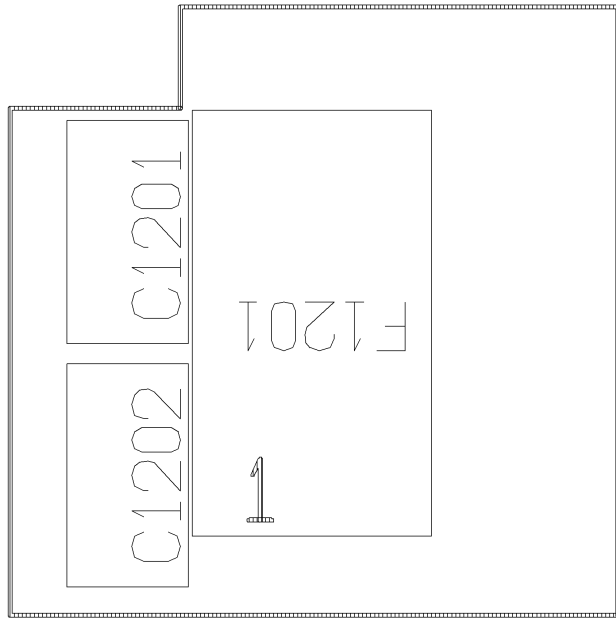

VBA20001-R. 3720. A

外 LCD FPC (表)
OUTSIDE LCD FPC (Surf face)

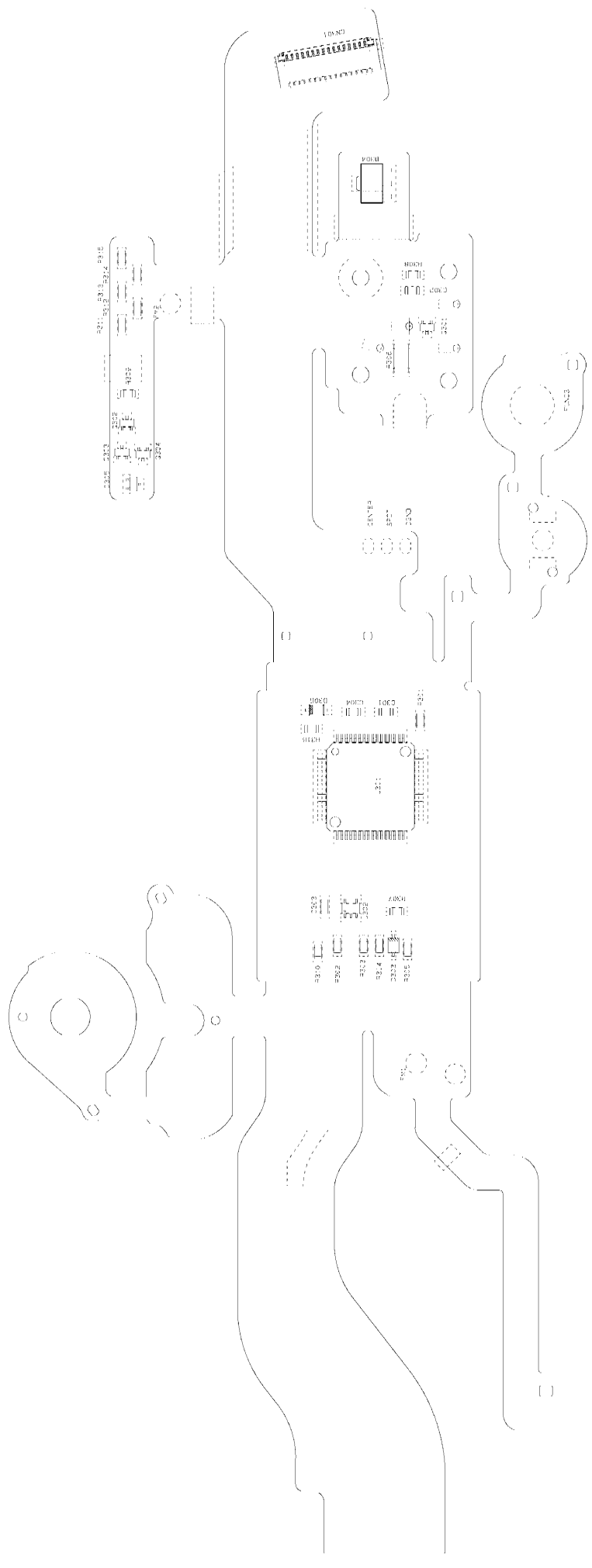

外 LCD FPC (裏)

OUTSIDE LCD FPC (Reverse face)

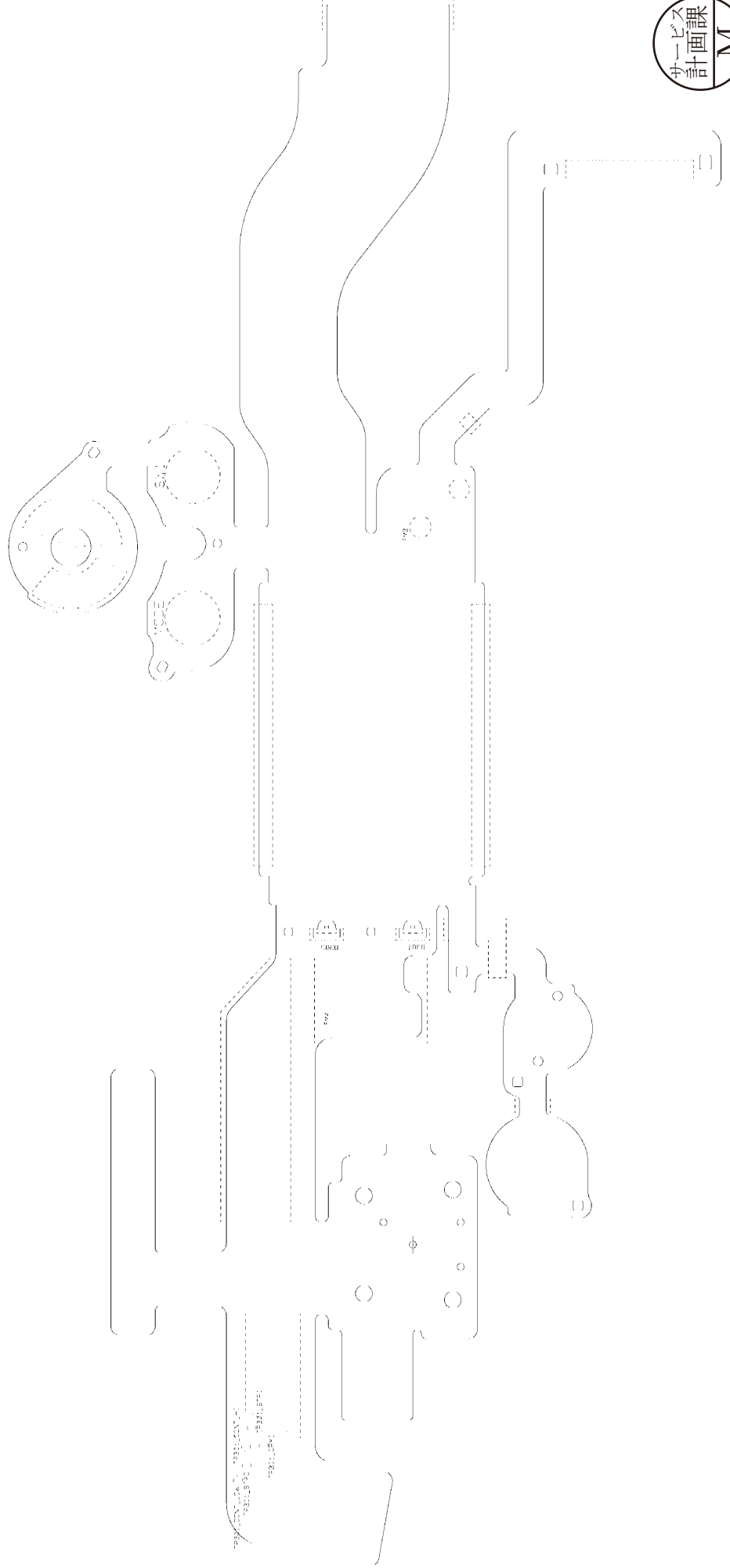

VBA20001-R. 3720. A

ペンタ FPC (表)

PENTA FPC (Surf face)

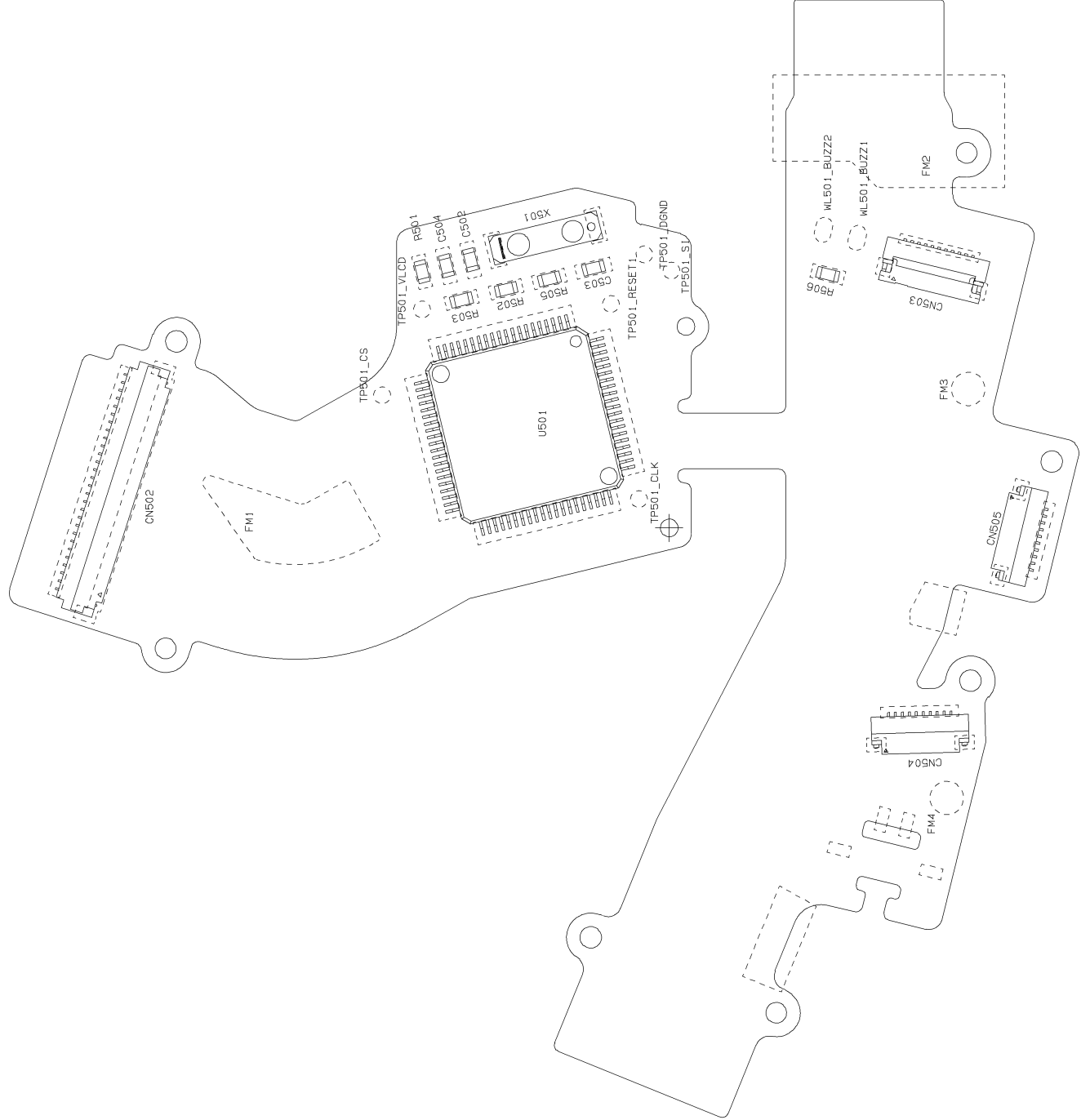

VBA20001-R. 3720. A

ペンタ FPC (裏)

PENTA FPC (Reverse face)

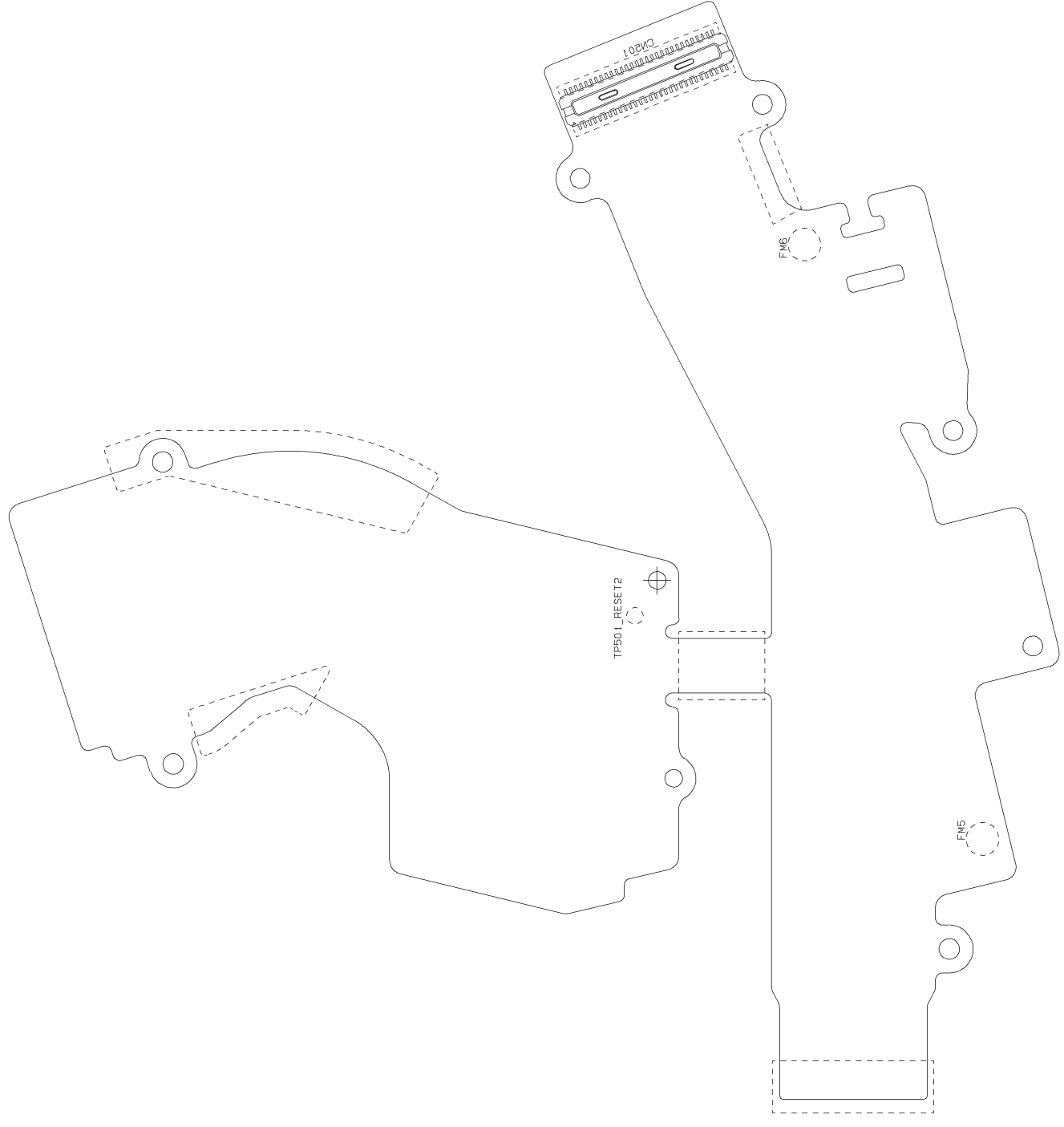

VBA20001-R. 3720. A

背面 FPC (裏)

REAR FPC (Reverse face)

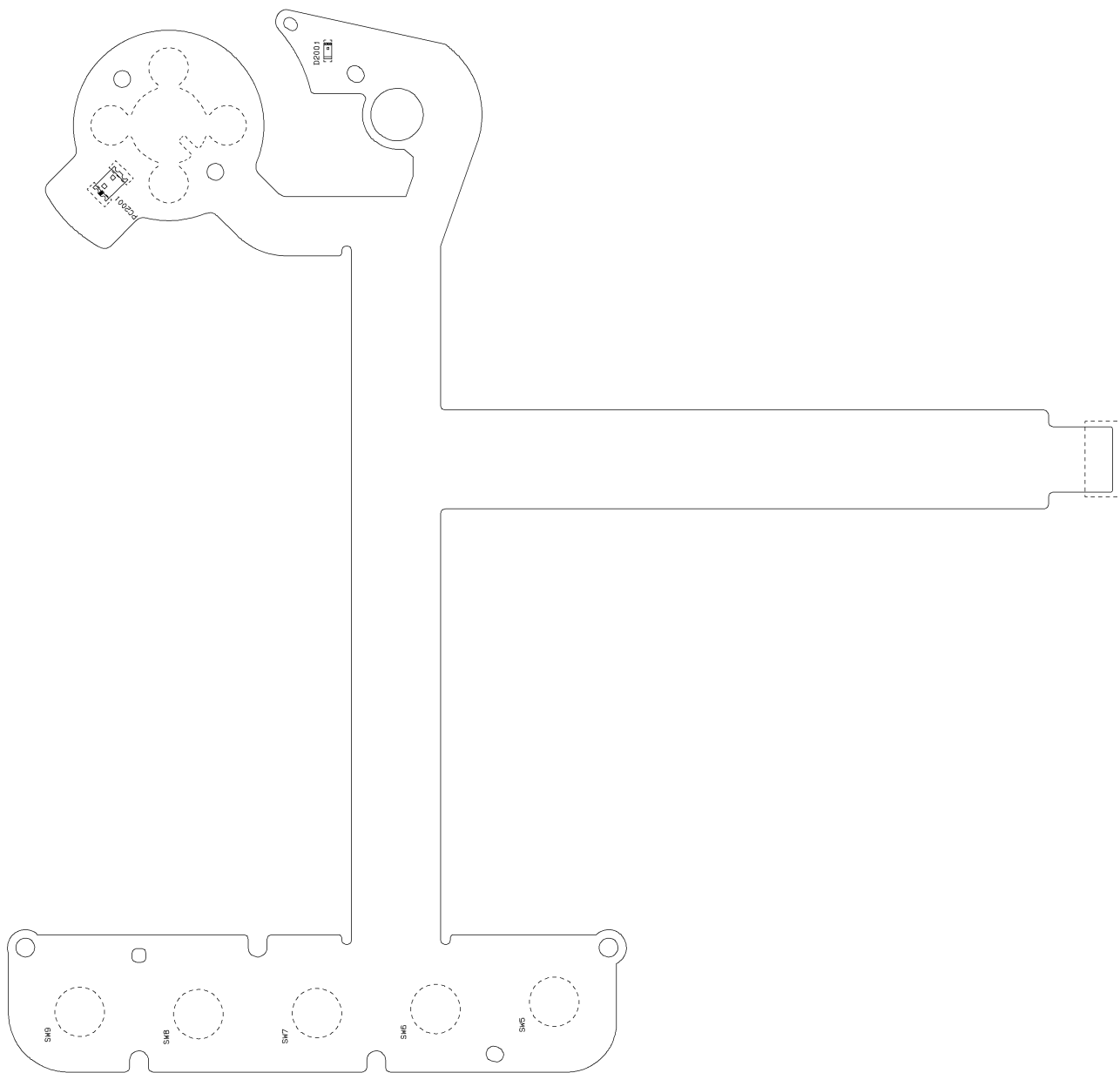

Inspection standards

Items	Judgment standard	Remarks
External view Step (height difference)	Btwn top cover & apron: 0.2 mm or less Other parts: 0.3 mm or less Moving parts: 0.5 mm or less	Visual check Digital micrometer
Gap	Btwn Top cover & Apron: 0.2 mm or less Btwn Top display panel window (surrounding) & Top cover: 0.45 mm or less Sub-command dial gap (lower part): 0.3mm ± 0.3 mm or less SB case & Top cover; SB case & Apron (when built-in speedlight is stored) : 0.5 mm or less Btwn Diopter adjusting knob (upper part) & Top cover : 0.7 mm or less Btwn Metering mode selector dial (upper part) & Top cover : 0.6 mm or less Other parts: 0.3 mm or less Moving parts: 0.5 mm or less	Visual check Thickness gauge
Size / Force Shutter release button	Protrusion: -3.95 ± 0.2 mm Halfway pressing force: 83 ± 15 g Halfway pressing stroke: 0.5 ± 0.1 mm Releasing force: 320 ± 50 g Releasing stroke: 0.3 ± 0.1 mm (Half-release pressing ON) Extra stroke after releasing button: 0.4 mm or more Difference btwn Half-releasing and Full pressing force: 235 ± 50 g	Digital micrometer Tension gauge
Aperture lever	3.4 height: $3.4 +0.1/-0.05$ mm	3.4 height gauge
Main mirror	45° angle: Up-down $\pm 10'$ Right-left $\pm 25'$ Distortion: 6' or less Clearance for up-mirror in mirror box: None Play: 0.2 mm or less	Collimator Main mirror tool Visual check Feeling in hand
Sub-mirror	59° angle: Up-down $0' +5'/-35'$ Right-left $\pm 20'$ Distortion: 8' or less	Sub-mirror tool
∞ Infinity focus	$\pm 80 \mu\text{m}$	

Items	Judgment standard	Remarks
AF accuracy Yaw Pitch Block Def amount	Center : ± 4 mrad Others: ± 10 mrad Center : ± 5 mrad Others: ± 11 mrad Others than Side: 0 ± 50 μm Side: 0 ± 60 μm	PC Special tool Brightness box
AF-assist illuminator Lighting level	Range from EV5.2 to 6.2	AF50/1.4D Brightness box
AE accuracy Exposure on image	1/8000, F2 (EV16) ※ : ± 0.6 EV 1/2000, F2.8 (EV14) ※ : ± 0.50 EV 1/250, F4 (EV12) ※ : ± 0.50 EV 1/60, F5.6 (EV11) ※ : ± 0.50 EV 1", F8 (EV6) ※ : ± 0.50 EV Dispersion: 0.3 EV Difference in AE mode: 0.4 EV Difference in Metering mode: 0.3 EV Data spread in min. aperture/continuous shooting: 0.5 EV	AF50/1.4D (∞) "A" light source brightness box < Judge under conditions of ISO200, Center weighted metering ($\phi 8$ mm), RAW data "G" (200*200 pixels) >
Shutter accuracy Speed accuracy Dispersion Shutter curtain speed Shutter curtain bound Synchronization	1/8000 : ± 0.55 EV 1/4000 : ± 0.35 EV 1/2000 ~ 30 sec.: ± 0.2 EV 1/8000 : 0.45 EV or less 1/4000 : 0.35 EV or less 1/2000 ~ 30 sec.: 0.25 EV or less Both front and rear curtains (up-down 16.6 mm or less): approx. 2.6 ms or less Black/white bound (within frame): None Timelag: (16.6mm-frame) : - 0.11 ~ 0.15 ms	Shutter speed tester



Items	Judgment standard	Remarks
Viewfinder Inner LCD lower panel window position Finder field frame Field of viewfinder (frame coverage) Parallax (Difference of center from the shot image/sensor) Eye point	Up-down position: No outstanding misalignment Tilt: 1 ° or less Lens vignetting/distortion: No outstanding vignetting/distortion Tilt: (based on Bottom cover): 30' or less Relative angle to image sensor: 30' or less In height and width: 100 + 0%/-2% Up-down: 0.15 mm or less Right-left: 0.15 mm or less Distance to eyepiece protective glass: 19.5±10%	Visual check AF50/1.4D, F5.6 Looking through viewfinder, measure a tilt of indication line (parallel to the bottom) from the bottom line of the frame. AF50/1.4D, F5.6 Mark a line indicating the field of viewfinder and take a picture. Then, measure a difference (tilt) between the marked indication line and actual shot. Vernier caliper Eye point tool
Screen misalignment	Tilt: 30' or less	E screen B screen Special chart
Sequence release time lag	AF-M: 60 ms or less AF-C: 60 ms or less Release with a one push: 210 ms or less Release when vibration reduction lens attached: : 60 ms or less Pre-flash release: 100 ms or less	Oscilloscope Constant-voltage power source Power tool EV9 VR70-200ED/ F2.8G AF-M, AE-A, AMP SB-800 (Multi-sensor balanced fill-flash) Measure the time taken from releasing the shutter to switching ON for X-signal.

Items	Judgment standard	Remarks
Standby (idle) / consumed current	Main SW / OFF: 150 μ A or less (Do NOT press any operational buttons.) Main SW / ON (Half-release timer: OFF): 150 μ A or less Main SW / ON (Half-release timer: ON): 220 m A or less Main SW / ON (Illumination: ON): 250 mA or less Main SW / ON (TFT ON): 300 mA or less During live view: 770 mA or less	Constant-voltage power source (5A or more) Battery tool (J61213) Ammeter AF50/1.4 EV12
Operation time / consumption current accumulated	Lens scan AF50/1.8 Operation time: 1000 ms or less Consumption current accumulated: 500 mAsec or less AF70-210/4-5.6 Operation time: 2000 ms or less Consumption current accumulated: 800 mAsec or less Preview Operation time: 150ms or less Consumption current accumulated: 100 mAsec or less Release without memory card Operation time: 180 ms or less Consumption current accumulated: 200 mAsec	Constant voltage power source (5A or more) Battery tool (J61210) Special tool Oscilloscope LV12
Rush current	Shooting operation: 4.0A or less	Constant voltage power source Battery tool (J61210) Special tool Oscilloscope LV12
Clock accuracy	Difference par month: \pm 30 seconds (20°C)	Wave clock
BC level	Level 0 5 lights up Charge remaining: 80 ~ 100% Level 1 4 lights up Charge remaining: 60 ~ 79% Level 2 3 lights up Charge remaining: 40 ~ 59% Level 3 2 lights up Charge remaining: 20 ~ 39% Level 4 1 light up Charge remaining: 1 ~ 19% Level 5 1 light blinking Charge remaining: 0%	Check the level in the LCD control panel on top of camera or TFT battery information Communication- capable battery tool
Bulb battery life	When special Li-ion is used: 1 and a half hours or more	Clock Remote wire









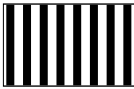
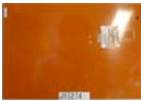

Items	Judgment standard	Remarks
Battery life EN-EL3e	General mode Room temperature: 600 frames or more 0°C 400 frames or more AF-S24-120/3.5-5.6 VR OFF, AF-C, Release mode dial: S, M1/250 F5.6, AF scan reciprocating motion once → Halfway press 6 sec. → Release once → TFT monitor 2 sec. → Half-release timer OFF (repeat) Professional mode Room temperature: 3200 frames or more 0°C 2700 frames or more AF-S70-200/2.8 VR OFF, AF-C, Release mode dial: Ch, M1/250 F5.6, AF scan reciprocating motion 3 times → Halfway press 3 sec. → Release 6 times → TFT monitor 5 sec. → Half-release timer OFF (repeat)	
Battery pack (MB-D10) EN-EL3e	General mode Room temperature: 600 frames or more 0°C 400 frames or more AF-S24-120/3.5-5.6 VR OFF, AF-C, Release mode dial: S, M1/250 F5.6, AF scan reciprocating motion once → Halfway press 6 sec. → Release once → TFT monitor 2 sec. → Half-release timer OFF (repeat) Professional mode Room temperature: 3000 frames or more 0°C 2500 frames or more AF-S70-200/2.8 VR OFF, AF-C, Release mode dial: Ch, M1/250 F5.6, AF scan reciprocating motion 3 times → Halfway press 3 sec. → Release 6 times → TFT monitor 5 sec. → Half-release timer OFF (repeat)	
Battery pack (MB-D10) EN-EL4a	General mode Room temperature: 1100 frames or more 0°C 900 frames or more AF-S24-120/3.5-5.6 VR OFF, AF-C, Release mode dial: S, M1/250 F5.6, AF scan reciprocating motion once → Halfway press 6 sec. → Release once → TFT monitor 2 sec. → Half-release timer OFF (repeat) Professional mode Room temperature: 7000 frames or more 0°C 5500 frames or more AF-S70-200/2.8 VR OFF, AF-C, Release mode dial: Ch, M1/250 F5.6, AF scan reciprocating motion 3 times → Halfway press 3 sec. → Release 6 times → TFT monitor 5 sec. → Half-release timer OFF (repeat)	
Battery pack (MB-D10) Alkaline battery	General mode Room temperature: 600 frames or more AF-S24-120/3.5-5.6 VR OFF, AF-C, Release mode dial: S, M1/250 F5.6, AF scan reciprocating motion once → Halfway press 6 sec. → Release once → TFT monitor 2 sec. → Half-release timer OFF (repeat) Professional mode Room temperature: 2500 frames or more AF-S70-200/2.8 VR OFF, AF-C, Release mode dial: Ch, M1/250 F5.6, AF scan reciprocating motion 3 times → Halfway press 3 sec. → Release 6 times → TFT monitor 5 sec. → Half-release timer OFF (repeat)	

Items	Judgment standard	Remarks
<p>Image-related Appropriate level</p>	<p><u>Judgment method</u> When RAW recorded: Within the area of 425 pixels x 425 pixels at the center of screen, calculate the average of G-12 bit data. When TIFF/JPEG recorded: Within the area of 425 pixels x 425 pixels at the center of screen, calculate the average of Y-8 bit data</p> <p><u>Standard</u> RAW At all ISO settings: $600 \pm 35\text{LSB} (\pm 0.08\text{EV})$</p> <p>TIFF/JPEG (Tone compensation: Normal, Low/Less contrast): Mode I (sRGB): At all ISO settings and Mode I 121^{+5}_{-6}LSB Mode II (adobeRGB): At all ISO settings and Mode II 117^{+5}_{-6}LSB Mode III (sRGB) : At all ISO settings and Mode III 119^{+5}_{-6}LSB</p> <p>TIFF/JPEG (Tone compensation: Normal, High/More contrast): Mode I (sRGB): At all ISO settings and Mode I 121^{+7}_{-8}LSB Mode II (adobeRGB) : At all ISO settings and Mode II 117^{+7}_{-8}LSB Mode III (sRGB): At all ISO settings and Mode III 119^{+7}_{-8}LSB</p>	<p>AF50mm/F1.4D(CPU built-in metering reference lens) F5.6 ISO100 1/30 LV10 ISO125 1/20 LV9 ISO160 1/25 LV9 ISO200 1/30 LV9 ISO250 1/20 LV8 ISO320 1/25 LV8 ISO400 1/30 LV8 ISO500 1/20 LV7 ISO640 1/25 LV7 ISO800 1/30 LV7 Light source: Color viewer Distance from object: Closely contact Focal length: Infinity AE: M mode Image size:L, M, S WB: Preset (for every sensitivity)</p>
<p>Color reproducibility</p>	<p><u>Judgment method</u> Shoot by exposure so that the batch 22 of Macbeth chart becomes $L = 50 \pm 2$.</p> <p><u>Standard</u> For every color Difference from target value: $\Delta C = 10$ or less</p>	<p>AF-MC105mm Object of shooting: Macbeth Color Checker (Background: black) Light source: Artificial sunshine AE: M (F5.6) Color mode: Mode I Image quality: JPEG Image size: L ISO100 ISO200 ISO400 ISO800</p>



工具・TOOLS









★：新規設定工具・NEW TOOL

工具番号 Tool No.	名称 Name of tool	備考 Others
J15259 	A F調整工具台 AF ADJUSTING TOOL	
J15280 	Zレンズ用支持ホルダー LENS HOLDER	
J15264 	高周波タイプ蛍光灯器具 ILLUMINATION BOX FOR AF ADJUSTMENT	
J15407 	マルチカム2000 AFチャート MULTI CAM 2000 AF CHART	FOR D2SERIESE
J15409 	チャートボード CHART BOARD	FOR D2SERIES, D40
J18001-1 	ボディバック出し工具 BODY BACK FOCUS GAUGE	
J18004 	絞りレバー高さ点検工具 Aperture lever positioning gauge	
J18010 	無限大合致基準レンズ50/1.8 INFINITY STANDARD LENS 50/1.8	払底品 OUT OF STOCK
J18191 	NDフィルター8× ND FILTER 8X	2枚使用 IT USES BY TWO PIECES.
J18230 	YAW・PITCH工具 YAW・PITCH ADJUSTMENT TOOL	FOR F5, F100, F90, F90X, D-SLR
J18266 	A F調整用Zレンズ(1m用) Z ADJUSTMENT LENS (FOR 1m)	FOR F5, F100, D-SLR
△(訂正) △(Revision) J18267 	A F 50/1.4 D LENS AF50/1.4D	製品転用 RJ IS NOT AVAILABLE

★ : 新規設定工具・NEW TOOL

工具番号 Tool No.	名称 Name of tool	備考 Others
J18358 	NDフィルター4× ND FILTER 4X	2枚使用 IT USES BY TWO PIECES.
J18389 	反射ミラー REFLECTION MIRROR	FOR D200, D80
J18394 	無限合致調整用スクリーン INFINITY FOCUS ADJUSTMENT SCREEN	FOR D200, D80
J18433 	カメラ部調整用ソフト ADJ. SOFT FOR CAMERA	
J19001 	∞合致コリメーターF=600mm COLLIMATOR F=600mm	
J19004-1 	インジケータ及びスタンド DIAL INDICATOR AND STAND	
J19109 	MC-31 (接続コード) MC-31 (CONNECTING CORD)	
J19123 	シャッター試験機 EF-1 (CE) SHUTTER TESTER EF-1 (CE)	共立電機製 KYORITSU ELECTRIC EF-8000 USABLE
J19132 	メイン・サブミラー角度検査機 MAIN/SUB MIRROR ANGLE INSPECTION TOOL	FOR D3, ETC
J61185 	撮像関係調整用レンズ D1 STANDARD LENS	FOR D-SLR
J61222 	二次元バーコードリーダー TWO-DIMENSIONAL BARCODE READER	FOR S10, ETC
J61223 	ライティングルーペ LIGHTING LOUPE	FOR D-SLR

★ : 新規設定工具・NEW TOOL

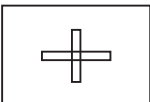
工具番号 Tool No.	名称 Name of tool	備考 Others
★ J61228 	D300 工具ボディ (撮像用基準ボディ) D300 TOOL BODY	
J63068 	輝度計 (BM-3000) LUMINANCE METER BM-3000	
J63070 	カラービューア COLOR VIEWER	
J63085 	フィルター SP1 FILTER SP1	FOR D2H, D70, D70s, D50, D200, D80, D40, D40x
J63086 	フィルター SP2 FILTER SP2	FOR D2H, D70, D70s, D50, D200, D80, D40, D40x
J63087 	フィルター SP3 FILTER SP3	FOR D2H, D70, D70s, D50, D200, D80, D40, D40x
J65096 	QRリーダーソフト QR READER SOFTWARE	FOR S10, ETC
★ J63100 	D300用AE CCD用チャートボード AE/CCD USE CHART BOARD FOR D300	
★ J63101 	D300用AF X-Yチャート AF X-Y CHART FOR D300	
★ J63103 	D300用視差・SIチャート PARALLAX/SI CHART FOR D300	

★ : 新規設定工具・NEW TOOL

工具番号 Tool No.	名称 Name of tool	備考 Others
C-8008B 	セメダイン 8008 (黒) CEMEDAIN 8008 (BLACK)	
EDB0011 	ネジロック (赤) 1401C SCREW LOCK 1401C	
LEN317A 	グリース LEN317A GREASE LEN317A	
OS-30MEL 	ドライサーフ OS-30MEL DRY SURF OS-30MEL (OIL BARRIER)	OS-30MF 使用可 OS-30MF IS AVAILABLE
	アロンアルファ QUICK DRYING GLUE	汎用品 RJ IS NOT AVAILABLE
	パーソナルコンピュータ	汎用品 RJ IS NOT AVAILABLE
	安定化電源 (10V 5A) POWER SUPPLY (10V 5A)	汎用品 RJ IS NOT AVAILABLE
	フラッシュメーター FLASH METER	汎用品 RJ IS NOT AVAILABLE
	ヘクスキー (φ1.5mm) HEX. KEY WRENCH (φ1.5mm)	汎用品 RJ IS NOT AVAILABLE
	AF 28/2.8D LENS AF28/2.8D	製品転用 RJ IS NOT AVAILABLE
	AF 70-200/4.5-6.3D or AF-SVR70-200/4.5-6.3 △ (訂正) △ (Revision) AF 70-300/4-5.6D or AF-SVR70-300/4.5-5.6 LENS AF 70-200/4.5-6.3D or AF-SVR70-200/4.5-6.3 △ (訂正) △ (Revision) LENS AF 70-300/4-5.6D or LENS AF-SVR70-300/4.5-5.6	製品転用 RJ IS NOT AVAILABLE
	USBケーブル UC-E4 USB CABLE UC-E4	製品転用 RJ IS NOT AVAILABLE
	ACアダプター EH-5 AC ADAPTER EH-5	製品転用 RJ IS NOT AVAILABLE
	MB-D10 BATTERY PACK MB-D10	製品転用 RJ IS NOT AVAILABLE

△ (追加)
△ (Addition)

